

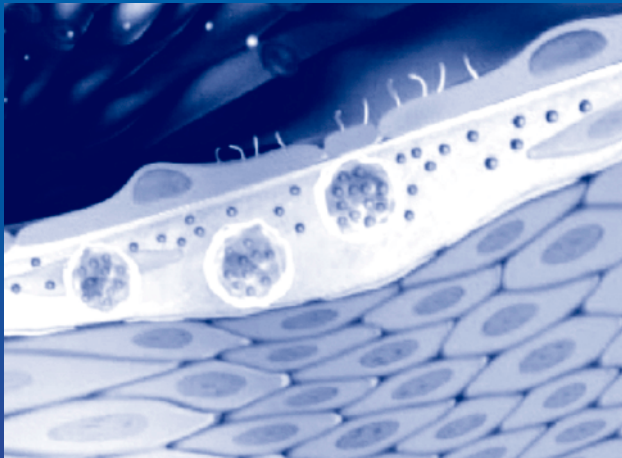
# Cardiovascular Biomarkers

*Pathophysiology  
and Disease Management*

---

*Edited by*

**David A. Morrow, MD, MPH**



 HUMANA PRESS

## CARDIOVASCULAR BIOMARKERS

# CONTEMPORARY CARDIOLOGY

---

CHRISTOPHER P. CANNON, MD, *EDITOR-IN-CHIEF*

ANNEMARIE M. ARMANI, MD, *EXECUTIVE EDITOR*

- Essential Echocardiography: A Practical Handbook**  
With DVD, edited by Scott D. Solomon, MD, 2006
- Preventive Cardiology: Insights Into the Prevention and Treatment of Cardiovascular Disease, Second Edition**, edited by JoAnne Micale Foody, MD, 2006
- The Art and Science of Cardiac Physical Examination: With Heart Sounds and Pulse Wave Forms on CD**, by Narasimhan Ranganathan, MD, Vahe Sivaciyan, MD, and Franklin B. Saksena, MD, 2006
- Cardiovascular Biomarkers: Pathophysiology and Disease Management**, edited by David A. Morrow, MD, 2006
- Cardiovascular Disease in the Elderly**, edited by Gary Gerstenblith, MD, 2005
- Platelet Function: Assessment, Diagnosis, and Treatment**, edited by Martin Quinn, MB BCH BAO, PhD, and Desmond Fitzgerald, MD, FRCP, FESC, APP, 2005
- Diabetes and Cardiovascular Disease, Second Edition**, edited by Michael T. Johnstone, MD, CM, FRCP(C), and Aristidis Veves, MD, DSc, 2005
- Angiogenesis and Direct Myocardial Revascularization**, edited by Roger J. Laham, MD, and Donald S. Baim, MD, 2005
- Interventional Cardiology: Percutaneous Noncoronary Intervention**, edited by Howard C. Herrmann, MD, 2005
- Principles of Molecular Cardiology**, edited by Marshall S. Runge, MD, and Cam Patterson, MD, 2005
- Heart Disease Diagnosis and Therapy: A Practical Approach, Second Edition**, by M. Gabriel Khan, MD, FRCP(LONDON), FRCP(C), FACP, FACC, 2005
- Cardiovascular Genomics: Gene Mining for Pharmacogenomics and Gene Therapy**, edited by Mohan K. Raizada, PhD, Julian F. R. Paton, PhD, Michael J. Katovich, PhD, and Sergey Kasparov, MD, PhD, 2005
- Surgical Management of Congestive Heart Failure**, edited by James C. Fang, MD and Gregory S. Couper, MD, 2005
- Cardiopulmonary Resuscitation**, edited by Joseph P. Ornato, MD, FACP, FACC, FACEP and Mary Ann Peberdy, MD, FACC, 2005
- CT of the Heart: Principles and Applications**, edited by U. Joseph Schoepf, MD, 2005
- Coronary Disease in Women: Evidence-Based Diagnosis and Treatment**, edited by Leslee J. Shaw, PhD and Rita F. Redberg, MD, FACC, 2004
- Cardiac Transplantation: The Columbia University Medical Center/New York-Presbyterian Hospital Manual**, edited by Niloo M. Edwards, MD, Jonathan M. Chen, MD, and Pamela A. Mazzeo, 2004
- Heart Disease and Erectile Dysfunction**, edited by Robert A. Kloner, MD, PhD, 2004
- Complementary and Alternative Cardiovascular Medicine**, edited by Richard A. Stein, MD and Mehmet C. Oz, MD, 2004
- Nuclear Cardiology, The Basics: How to Set Up and Maintain a Laboratory**, by Frans J. Th. Wackers, MD, PhD, Wendy Bruni, BS, CNMT, and Barry L. Zaret, MD, 2004
- Minimally Invasive Cardiac Surgery, Second Edition**, edited by Daniel J. Goldstein, MD, and Mehmet C. Oz, MD 2004
- Cardiovascular Health Care Economics**, edited by William S. Weintraub, MD, 2003
- Platelet Glycoprotein IIb/IIIa Inhibitors in Cardiovascular Disease, Second Edition**, edited by A. Michael Lincoff, MD, 2003
- Heart Failure: A Clinician's Guide to Ambulatory Diagnosis and Treatment**, edited by Mariell L. Jessup, MD and Evan Loh, MD, 2003
- Management of Acute Coronary Syndromes, Second Edition**, edited by Christopher P. Cannon, MD 2003
- Aging, Heart Disease, and Its Management: Facts and Controversies**, edited by Niloo M. Edwards, MD, Mathew S. Maurer, MD, and Rachel B. Wellner, MPH, 2003
- Peripheral Arterial Disease: Diagnosis and Treatment**, edited by Jay D. Coffman, MD and Robert T. Eberhardt, MD, 2003
- Cardiac Repolarization: Bridging Basic and Clinical Science**, edited by Ihor Gussak, MD, PhD, Charles Antzelevitch, PhD, Stephen C. Hammill, MD, Win K. Shen, MD, and Preben Bjerregaard, MD, DMSc, 2003

# CARDIOVASCULAR BIOMARKERS

## *Pathophysiology and Disease Management*

---

*Edited by*

**DAVID A. MORROW, MD, MPH**

*Cardiovascular Division,  
Brigham and Women's Hospital,  
Harvard Medical School,  
Boston, MA*

*Foreword by*

**ELLIOT ANTMAN, MD**

*Brigham and Women's Hospital,  
Harvard Medical School,  
Boston, MA*



**HUMANA PRESS**  
TOTOWA, NEW JERSEY

© 2006 Humana Press Inc.  
999 Riverview Drive, Suite 208  
Totowa, New Jersey 07512  
[www.humanapress.com](http://www.humanapress.com)

All rights reserved. No part of this book may be reproduced, stored in a retrieval system, or transmitted in any form or by any means, electronic, mechanical, photocopying, microfilming, recording, or otherwise without written permission from the Publisher.

The content and opinions expressed in this book are the sole work of the authors and editors, who have warranted due diligence in the creation and issuance of their work. The publisher, editors, and authors are not responsible for errors or omissions or for any consequences arising from the information or opinions presented in this book and make no warranty, express or implied, with respect to its contents.

Due diligence has been taken by the publishers, editors, and authors of this book to assure the accuracy of the information published and to describe generally accepted practices. The contributors herein have carefully checked to ensure that the drug selections and dosages set forth in this text are accurate and in accord with the standards accepted at the time of publication. Notwithstanding, as new research, changes in government regulations, and knowledge from clinical experience relating to drug therapy and drug reactions constantly occurs, the reader is advised to check the product information provided by the manufacturer of each drug for any change in dosages or for additional warnings and contraindications. This is of utmost importance when the recommended drug herein is a new or infrequently used drug. It is the responsibility of the treating physician to determine dosages and treatment strategies for individual patients. Further it is the responsibility of the health care provider to ascertain the Food and Drug Administration status of each drug or device used in their clinical practice. The publisher, editors, and authors are not responsible for errors or omissions or for any consequences from the application of the information presented in this book and make no warranty, express or implied, with respect to the contents in this publication.

Production Editor: Tracy Catanese

Cover design by Patricia F. Cleary

Cover Illustration: Figure 1D from Chapter 14, "Inflammation in Cardiovascular Disease: *The Biological Basis of Inflammatory Biomarkers*," by Peter Libby.

For additional copies, pricing for bulk purchases, and/or information about other Humana titles, contact Humana at the above address or at any of the following numbers: Tel.: 973-256-1699; Fax: 973-256-8341, E-mail: [orders@humanapr.com](mailto:orders@humanapr.com); or visit our Website: [www.humanapress.com](http://www.humanapress.com)

This publication is printed on acid-free paper. ∞

ANSI Z39.48-1984 (American National Standards Institute) Permanence of Paper for Printed Library Materials.

#### Photocopy Authorization Policy:

Authorization to photocopy items for internal or personal use, or the internal or personal use of specific clients, is granted by Humana Press Inc., provided that the base fee of US \$30.00 is paid directly to the Copyright Clearance Center at 222 Rosewood Drive, Danvers, MA 01923. For those organizations that have been granted a photocopy license from the CCC, a separate system of payment has been arranged and is acceptable to Humana Press Inc. The fee code for users of the Transactional Reporting Service is: [1-58829-526-5/06 \$30.00].

Printed in the United States of America. 10 9 8 7 6 5 4 3 2 1

eISBN 159745-051-0

Library of Congress Cataloging-in-Publication Data

Cardiovascular biomarkers : pathophysiology and disease management

/ edited by David A. Morrow.

p. ; cm. -- (Contemporary cardiology)

Includes bibliographical references and index.

ISBN 1-58829-526-5 (alk. paper)

1. Cardiovascular system--Diseases--Diagnosis--Handbooks, manuals, etc. 2. Biochemical markers--Diagnostic use--Handbooks, manuals, etc.

I. Morrow, David A. II. Series: Contemporary cardiology (Totowa, N.J. : Unnumbered)

[DNLM: 1. Heart Diseases--therapy. 2. Biological Markers. WG 210

C2684 2006]

RC670.C35 2006

616.l'075--dc22

# FOREWORD

---

In the four pages committed to a discussion of myocardial infarction in the first edition of Harrison's *Principles of Internal Medicine*, published in 1950, there was no mention of use of the laboratory for management of patients. Thirty years later, when the first edition of Braunwald's *Heart Disease, A Textbook of Cardiovascular Medicine* was published, 2 out of the 1943 pages in the text contained a discussion of the laboratory examinations in acute myocardial infarction. Our knowledge base of the multitude of ways that physicians can and should use the clinical chemistry laboratory has expanded dramatically since these classic texts were published. The nomenclature has changed: terms such as "cardiac enzymes" have given way to "cardiac biomarkers." The number of assays has multiplied, and the operating characteristics of available assays are improving at a gratifying but dizzying rate. We now use biomarkers to diagnose cardiovascular diseases and also to frame our treatment strategies. Thus, there is a clear need for a scholarly compilation of the state of the art of cardiac biomarkers.

Dr. David Morrow has expertly edited an authoritative book that answers this need. The 34 chapters in *Cardiovascular Biomarkers: Pathophysiology and Disease Management* were written by a group of individuals who are internationally recognized thought leaders and experts in clinical and laboratory medicine. The first six sections reflect a contemporary division of cardiac biomarkers into those that inform clinicians about their patients with respect to myocyte necrosis, ischemia, inflammation, hemodynamic stress, platelet function and hemostasis, and dyslipidemia. A particularly noteworthy section is the last one, which presents the cutting edge concepts of a multimarker approach, point-of-care testing, proteomics, and genetic markers.

This book answers several major questions in clinical medicine today: How well do the various assays perform? Which ones should I order to evaluate my patient? How should I change my therapeutic approach based on the results of a biomarker assay? Given these strengths, readers of this text will find it an invaluable resource regardless of their familiarity with the subject.

*Elliott Antman, MD*  
*Brigham and Women's Hospital,*  
*Harvard Medical School,*  
*Boston, MA*



# PREFACE

---

Integration of cardiac biomarkers into clinical care has been accelerating at a dramatic pace. As novel applications of established biomarkers are tested and new markers complete development, the value of cardiac biomarkers for supporting clinical decision making is achieving greater recognition. This progress in the use of biomarkers is likely to gain even greater momentum in the era of personalized medicine. With expansion of the number and types of biomarkers available, the opportunity to improve diagnosis, risk stratification, and selection of therapy using these noninvasive, affordable tools continues to grow. Congruent with this evolution, the practicing clinician will benefit from a thorough understanding of the biology, technology, and clinical evidence underlying the use of established and emerging biomarkers in cardiovascular disease.

*Cardiovascular Biomarkers: Pathophysiology and Disease Management* is aimed at meeting the needs not only of the practicing clinician but also the interests of clinician-scientists, medical trainees, and laboratorians. The book is divided into seven sections, each of which covers a major class of biomarkers (e.g., biomarkers of necrosis, biomarkers of inflammation, and biomarkers of hemodynamic stress). Each section begins with an overview of the biology and development of each major class, followed by a concise review of analytic issues important to the clinician, and then by a series of chapters written by internationally recognized experts who discuss clinical applications of the biomarkers. These latter chapters focus on the incorporation of biomarkers into the contemporary management of patients with cardiovascular disease, emphasizing clinical studies, evidence-based diagnostic algorithms, and critical pathways for triage and therapy, wherever they are applicable. In addition to an in-depth discussion of available markers, each section includes at least one chapter that looks forward with a view to the future of the class. The heavy use of figures, illustrations, and tables, as well as integration of the chapters, are aimed at making the key evidence and practical guidelines easily accessible to the reader.

On a personal note, it has been a tremendous privilege and pleasure to work with the exceptional group of experts who have contributed to this text, and I wish to thank each of them. Foremost, I wish to recognize the sage and nurturing mentorship of Drs. Eugene Braunwald and Elliott Antman who, through their vision and creativity, sparked my fascination with this field. To them and to my numerous colleagues in the TIMI Study Group and Cardiovascular Division at Brigham and Women's Hospital, who make this area of research engaging and exciting, I extend my deepest gratitude. Also, without Sylvia Judd, my Editorial Associate for this project, it simply would not have been possible.

*David A. Morrow, MD, MPH*





# CONTENTS

---

Foreword .....	v
Preface .....	vii
Contributors .....	xiii
E-Book/PDA on CD-rom .....	xii

## PART I BIOMARKERS OF NECROSIS

1	Biomarkers of Myocardial Necrosis: <i>Past, Present, and Future</i> .....	3
	<b>Robert H. Christenson and Hassan M. E. Azzazy</b>	
2	Analytical Issues for the Clinical Use of Cardiac Troponin .....	25
	<b>Alan H. B. Wu</b>	
3	Defining Myocardial Infarction .....	39
	<b>Allan S. Jaffe and Luciano Babuin</b>	
4	Biomarkers in the Emergency Department: <i>Rapid Diagnosis and Triage</i> .....	59
	<b>Jin H. Han and W. Brian Gibler</b>	
5	Cardiac Troponin for Risk Assessment and Management of Non-ST-Elevation Acute Coronary Syndrome .....	77
	<b>Bertil Lindahl</b>	
6	Biomarkers of Necrosis for Risk Assessment and Management of ST-Elevation Myocardial Infarction .....	91
	<b>Evangelos Giannitsis and Hugo A. Katus</b>	
7	Cardiac Troponin After Revascularization Procedures .....	101
	<b>Warren J. Cantor and L. Kristin Newby</b>	
8	Biomarkers of Necrosis in Heart Failure: <i>Past, Present, and Future Directions</i> .....	117
	<b>Emil Missov, James Rider, and Leslie Miller</b>	
9	Is There a Role for Cardiac Troponin and Other Biomarkers in Patients With Pulmonary Embolism? .....	127
	<b>Samuel Z. Goldhaber</b>	
10	Cardiac Troponin in Conditions Other Than Acute Coronary Syndromes .....	137
	<b>Fred S. Apple and David A. Morrow</b>	
11	Degradation of Cardiac Troponins: <i>Implications for Clinical Practice</i> .....	159
	<b>Allan S. Jaffe and Jennifer E. Van Eyk</b>	

---

<b>PART II BIOMARKERS OF ISCHEMIA</b>	
12	Developing a Marker of Ischemia: <i>Clinical and Research Challenges</i> ..... 175 <b>Robert L. Jesse</b>
13	Emerging Biomarkers of Myocardial Ischemia ..... 191 <b>Jesse E. Adams</b>
<b>PART III BIOMARKERS OF INFLAMMATION</b>	
14	Inflammation in Cardiovascular Disease: <i>The Biological Basis of Inflammatory Biomarkers</i> ..... 205 <b>Peter Libby</b>
15	Analytic Issues for the Clinical Use of C-Reactive Protein ..... 221 <b>Nader Rifai</b>
16	C-Reactive Protein as a Tool for Risk Assessment in Primary Prevention ..... 235 <b>Shari S. Bassuk and Paul M Ridker</b>
17	High-Sensitivity C-Reactive Protein for Risk Assessment in Acute Coronary Syndromes ..... 259 <b>Luigi M. Biasucci and Antonio Abbate</b>
18	Beyond C-Reactive Protein: <i>Novel Markers of Vascular Inflammation</i> ..... 175 <b>Christopher Heeschen</b>
19	Biomarkers of Inflammation: <i>Implications in Patients With Heart Failure</i> ..... 293 <b>Biykem Bozkurt</b>
20	Biomarkers of Infection and Risk of Coronary Heart Disease ..... 317 <b>Joseph B. Muhlestein</b>
<b>PART IV BIOMARKERS OF HEMODYNAMIC STRESS</b>	
21	Biology of the Natriuretic Peptides ..... 345 <b>Charlotte Kragelund and Torbjørn Omland</b>
22	Analytic Issues for the Clinical Use of B-Type Natriuretic Peptide and N-Terminal Pro B-Type Natriuretic Peptide ..... 371 <b>Johannes Mair</b>
23	Clinical Use of Natriuretic Peptides for the Diagnosis and Management of Heart Failure ..... 385 <b>Alan Maisel</b>
24	Natriuretic Peptides in Acute and Chronic Coronary Artery Disease ..... 407 <b>Shuaib M. Abdullah and James A. de Lemos</b>
25	Novel Markers of Hemodynamic Stress ..... 425 <b>Ellen O. Weinberg and Richard T. Lee</b>

---

<b>PART V</b>	<b>BIOMARKERS OF PLATELET FUNCTION AND HEMOSTASIS</b>	
26	Clinical and Research Applications of Markers of Thrombosis .....	449
	<i>Manesh R. Patel and Richard C. Becker</i>	
27	Measures of Platelet Activation and Aggregation .....	465
	<i>Jean-Philippe Collet and Gilles Montalescot</i>	
28	Monocyte-Platelet Aggregates in Patients With Ischemic Heart Disease .....	485
	<i>Matthew D. Linden and Mark I. Furman</i>	
<b>PART VI</b>	<b>BIOMARKERS OF DYSLIPIDEMIA AND LIPID MODIFICATION</b>	
29	Measurement of Atherogenic Lipoproteins in Cardiovascular Risk Assessment .....	495
	<i>Richard L. Dunbar and Daniel J. Rader</i>	
30	Lipoprotein-Associated Phospholipase A <sub>2</sub> and Other Lipid-Related Biomarkers in Cardiovascular Disease .....	517
	<i>Natalie Khuseyinova and Wolfgang Koenig</i>	
<b>PART VII</b>	<b>CONTEMPORARY AND FUTURE APPLICATIONS OF BIOMARKERS IN CLINICAL CARE</b>	
31	A Multimarker Approach to Evaluation of Patients With Acute Coronary Syndrome .....	543
	<i>David A. Morrow</i>	
32	Cardiac Biomarkers by Point-of-Care Testing .....	559
	<i>Paul O. Collinson</i>	
33	Proteomics and Cardiovascular Biomarker Discovery .....	575
	<i>Emerson Liu and Robert E. Gerszten</i>	
34	Genetic Markers in Cardiovascular Disease .....	587
	<i>Marc S. Sabatine</i>	
Index .....		609



# CONTRIBUTORS

---

- ANTONIO ABBATE, MD • *Resident in Internal Medicine, Department of Internal Medicine, Medical College of Virginia Hospitals, Virginia Commonwealth University, Richmond, VA*
- SHUAIB M. ABDULLAH, MD • *Cardiology Fellow, UT Southwestern Medical Center, Dallas, TX*
- JESSE E. ADAMS, MD, FACC • *Investigator, Medical Center Cardiologists, Jewish Hospital Heart and Lung Institute, Louisville, KY*
- FRED S. APPLE, PhD • *Medical Director, Clinical Laboratories, Hennepin County Medical Center, Professor of Laboratory Medicine and Pathology, University of Minnesota School of Medicine, Minneapolis, MN*
- HASSAN M. E. AZZAZY, PhD, DABCC • *Associate Professor, Department of Chemistry, School of Sciences and Engineering, The American University In Cairo, Cairo, Egypt*
- LUCIANO BABUIN, MD • *Visiting Research Fellow, Mayo Clinic and Graduate Medical School, Mayo Clinic, Rochester, MN*
- SHARI S. BASSUK, ScD • *Epidemiologist, Division of Preventive Medicine, Brigham and Women's Hospital, Harvard Medical School, Boston, MA*
- RICHARD C. BECKER, MD • *Professor of Medicine and Director, Duke Cardiovascular Thrombosis Center, Duke Clinical Research Institute, Division of Cardiology, Duke University Medical Center, Durham, NC*
- LUIGI M. BIASUCCI, MD, FACC, FAHA, FESC • *Assistant Professor of Cardiology, Director of Sub-intensive Care Unit, Department of Cardiovascular Medicine, Institute of Cardiology, Catholic University of the Sacred Heart, Rome, Italy*
- BIYKEM BOZKURT, MD, FACC • *Associate Professor of Medicine, and Acting Chief, Section of Cardiology, Department of Medicine, Michael E. DeBakey Veterans Affairs Medical Center and Winters Center for Heart Failure Research, Baylor College of Medicine, Houston, TX*
- WARREN J. CANTOR, MD • *Assistant Professor of Medicine, Division of Cardiology, St. Michael's Hospital, University of Toronto, Toronto, Ontario, Canada*
- ROBERT H. CHRISTENSON, PhD • *Professor of Pathology and Professor of Medical and Research Technology, Departments of Pathology and Medical & Research Technology, University of Maryland School of Medicine, Baltimore, MD*
- JEAN-PHILIPPE COLLET, MD, PhD • *Doctor, Institut de Cardiologie, Hôpital Pitié-Salpêtrière, Paris, France*
- PAUL O. COLLINSON, MD, FRCPath, FACB • *Director of Pathology and Consultant in Chemical Pathology, Department of Chemical Pathology, St George's Hospital, London, UK*
- JAMES A. DE LEMOS, MD • *Associate Professor of Medicine, CCU Director, Parkland Hospital, UT Southwestern Medical Center, Dallas, TX*

- RICHARD L. DUNBAR, MD • *Clinical Research Associate, Cardiovascular Risk Intervention Program, University of Pennsylvania School of Medicine, Philadelphia, PA*
- MARK I. FURMAN, MD • *Associate Professor of Medicine and Cell Biology, Center for Platelet Function Studies, and Division of Cardiovascular Medicine, University of Massachusetts Medical School, Worcester, MA*
- ROBERT E. GERSZTEN, MD • *Assistant Professor of Medicine, Cardiology Division, Harvard Medical School, and Center for Immunology and Inflammatory Diseases, Department of Medicine, Massachusetts General Hospital, Charlestown, MA*
- EVANGELOS GIANNITSIS, MD • *Assistant Professor of Medicine, Department of Cardiology, Medizinische Universitätsklinik Heidelberg, Abteilung für Innere Medizin III, Heidelberg, Germany*
- W. BRIAN GIBLER, MD • *Professor and Chairman, Department of Emergency Medicine, University of Cincinnati Medical Center, Cincinnati, OH*
- SAMUEL Z. GOLDBERGER, MD • *Professor of Medicine, Cardiovascular Division, Brigham and Women's Hospital, Harvard Medical School, Boston, MA*
- JIN H. HAN, MD • *Assistant Professor, Department of Emergency Medicine, University of Cincinnati Medical Center, Cincinnati, OH*
- CHRISTOPHER HEESCHEN, MD • *Associate Professor of Experimental Medicine, Molecular Cardiology, Johann Wolfgang Goethe University, Frankfurt, Germany*
- ALLAN S. JAFFE, MD • *Consultant in Cardiology and Laboratory Medicine and Pathology, Professor of Medicine, Cardiovascular Division, Mayo Clinic, Rochester, MN*
- ROBERT L. JESSE, MD, PhD • *Assistant Professor, Cardiology, Co-Director, Acute Cardiac Care, Coronary ICU, Virginia Commonwealth University Health System, Chief, Cardiology Section, Department of Veterans Affairs Medical Center, Richmond, VA*
- HUGO A. KATUS, MD • *Professor of Medicine, Department of Cardiology, Medizinische Universitätsklinik Heidelberg, Abteilung für Innere Medizin III, Heidelberg, Germany*
- NATALIE KHUSEYINOVA, MD • *Research Associate, Department of Internal Medicine I, Cardiology, University of Ulm Medical Center, Ulm, Germany*
- WOLFGANG KOENIG MD, PhD • *Professor of Medicine/Cardiology, Department of Internal Medicine I, Cardiology, University of Ulm Medical Center, Ulm, Germany*
- CHARLOTTE KRAGELUND, MD • *Post-Doctoral Fellow, Department of Medicine, Akershus University Hospital, University of Oslo, Nordbyhagen, Norway*
- RICHARD T. LEE, MD • *Associate Professor of Medicine, Cardiovascular Division, Department of Medicine, Brigham and Women's Hospital, Harvard Medical School, Boston, MA*
- PETER LIBBY, MD • *Mallinckrodt Professor of Medicine, Chief, Cardiovascular Medicine, Department of Medicine, Brigham and Women's Hospital, Harvard Medical School, Boston, MA*
- BERTIL LINDAHL, MD, PhD, FESC • *Associate Professor, Department of Cardiology and Uppsala Clinical Research Center, University Hospital, Uppsala, Sweden*

- MATTHEW D. LINDEN, PhD • *Senior Postdoctoral Fellow, Center for Platelet Function Studies, and Department of Pediatrics, University of Massachusetts Medical School, Worcester, MA*
- EMERSON LIU, MD • *Research Fellow, Cardiology Division, Harvard Medical School, and Center for Immunology and Inflammatory Diseases, Department of Medicine, Massachusetts General Hospital, Charlestown, MA*
- JOHANNES MAIR, MD • *Associate Professor, Cardiologist and Clinical Chemist, Clinical Division of Cardiology, Innsbruck Medical University, Innsbruck, Austria*
- ALAN MAISEL, MD • *Professor of Medicine, Director of the Coronary Care and Heart Failure Program, San Diego VA Healthcare System, University of California at San Diego, San Diego, CA*
- LESLIE MILLER, MD • *Professor of Medicine, Director, Cardiovascular Division, University of Minnesota Medical School, Minneapolis, MN*
- EMIL MISSOV, MD, PhD • *Assistant Professor of Medicine, Director Clinical Trials Center Laboratory, Cardiovascular Division, University of Minnesota Medical School, Minneapolis, MN*
- GILLES MONTALESCOT, MD, PhD • *Professor of Medicine, Institut de Cardiologie, Hôpital Pitié-Salpêtrière, Paris, France*
- DAVID A. MORROW, MD, MPH • *Assistant Professor of Medicine, Cardiovascular Division, Department of Medicine, Harvard Medical School and Brigham and Women's Hospital, Boston, MA*
- JOSEPH B. MUHLESTEIN, MD • *Associate Professor of Medicine, Division of Cardiology, LDS Hospital, University of Utah School of Medicine, Salt Lake City, UT*
- L. KRISTIN NEWBY, MD, MHS • *Associate Professor of Medicine, Duke Clinical Research Institute, Duke University Medical Center, Durham, NC*
- TORBJØRN OMLAND MD, PhD, MPH • *Professor of Medicine, Faculty Division Akershus University Hospital, University of Oslo, Nordbyhagen, Norway*
- MANESH R. PATEL, MD • *Cardiology Fellow, Duke Clinical Research Institute, Cardiovascular Thrombosis Center and Division of Cardiology, Duke University Medical Center, Durham, NC*
- DANIEL J. RADER, MD • *Director, Preventive Cardiology and Lipid Clinic, Cardiovascular Medicine Division, Presbyterian Medical Center, Associate Professor of Medicine, University of Pennsylvania School of Medicine, Philadelphia, PA*
- JAMES RIDER, MD • *Fellow in Cardiovascular Disease, Cardiovascular Division, University of Minnesota Medical School, Minneapolis, MN*
- PAUL M RIDKER, MD, MPH • *Eugene Braunwald Professor of Medicine, Division of Cardiovascular Disease Prevention, Director, Center for Cardiovascular Disease Prevention and the Donald W. Reynolds Center for Cardiovascular Research, Brigham and Women's Hospital, Harvard Medical School, Boston, MA*
- NADER RIFAI, PhD • *Louis Joseph Gay-Lussac Chair in Laboratory Medicine, Director of Clinical Chemistry, Children's Hospital, and Professor of Pathology, Harvard Medical School, Boston, MA*
- MARC S. SABATINE, MD, MPH • *Associate Physician, Department of Medicine, Cardiovascular Division, Brigham and Women's Hospital, Boston, MA*



JENNIFER E. VAN EYK, PhD • *Director, The Hopkins NHLBI Proteomics Center and Bayview Proteomics Group, Associate Professor of Medicine, Division of Cardiology, and Biological Chemistry and Biomedical Engineering, Johns Hopkins University School of Medicine, Baltimore, MD*

ELLEN O. WEINBERG, PhD • *Assistant Professor of Medicine, Cardiovascular Division, Department of Medicine, Boston University Medical Center, Boston, MA*

ALAN H. B. WU, PhD • *Chief, Clinical Chemistry Laboratory, San Francisco General Hospital, Professor, Department of Laboratory Medicine, University of California, San Francisco, CA*

# E-BOOK/PDA ON CD-ROM

---

This book is accompanied by a value-added CD-ROM that contains an eBook version of the volume you have just purchased. This eBook can be viewed on your computer, and you can synchronize it to your PDA for viewing on your handheld device. The eBook enables you to view this volume on only one computer and PDA. Once the eBook is installed on your computer, you cannot download, install, or e-mail it to another computer; it resides solely with the computer to which it is installed. The license provided is for only one computer. The eBook can only be read using Adobe® Reader® 6.0 software, which is available free from Adobe Systems Incorporated at [www.Adobe.com](http://www.Adobe.com). You may also view the eBook on your PDA using the Adobe® PDA Reader® software that is also available free from Adobe.com.

You must follow a simple procedure when you install the eBook/PDA that will require you to connect to the Humana Press website in order to receive your license. Please read and follow the instructions below:

1. Download and install Adobe® Reader® 6.0 software

You can obtain a free copy of the Adobe® Reader® 6.0 software at [www.adobe.com](http://www.adobe.com)

*\*Note: If you already have the Adobe® Reader® 6.0 software installed, you do not need to reinstall it.*

2. Launch Adobe® Reader® 6.0 software

3. Install eBook: Insert your eBook CD into your CD-ROM drive

PC: Click on the “Start” button, then click on “Run”

At the prompt, type “d:\ebookinstall.pdf” and click “OK”

*\*Note: If your CD-ROM drive letter is something other than d: change the above command accordingly.*

MAC: Double click on the “eBook CD” that you will see mounted on your desktop.

Double click “ebookinstall.pdf”

4. Adobe® Reader® 6.0 software will open and you will receive the message

“This document is protected by Adobe DRM” Click “OK”

*\*Note: If you have not already activated the Adobe® Reader® 6.0 software, you will be prompted to do so. Simply follow the directions to activate and continue installation.*

Your web browser will open and you will be taken to the Humana Press eBook registration page. Follow the instructions on that page to complete installation. You will need the serial number located on the sticker sealing the envelope containing the CD-ROM.

If you require assistance during the installation, or you would like more information regarding your eBook and PDA installation, please refer to the eBookManual.pdf located on your CD. If you need further assistance, contact Humana Press eBook Support by e-mail at [ebooksupport@humanapr.com](mailto:ebooksupport@humanapr.com) or by phone at 973-256-1699.

\*Adobe and Reader are either registered trademarks or trademarks of Adobe Systems Incorporated in the United States and/or other countries.



# I

---

## BIOMARKERS OF NECROSIS

---



# 1

---

## Biomarkers of Myocardial Necrosis

*Past, Present, and Future*

---

*Robert H. Christenson, PhD*

*and Hassan M. E. Azzazy, PhD, DABCC*

### CONTENTS

INTRODUCTION

BACKGROUND: BIOMARKERS OF CARDIAC NECROSIS

NECROSIS BIOMARKERS OF THE PAST

NECROSIS BIOMARKERS OF THE PRESENT

NECROSIS BIOMARKERS STILL IN DEVELOPMENT

FUTURE MARKERS OF MYOCARDIAL NECROSIS

CONCLUSION

REFERENCES

---

### SUMMARY

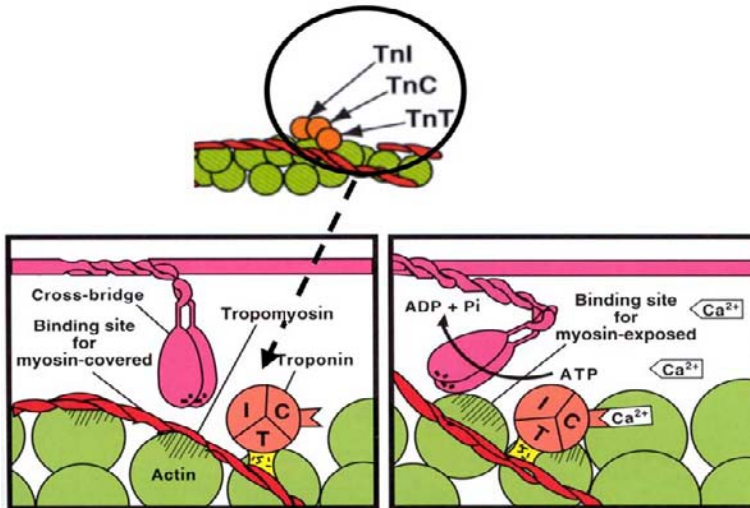
Biochemical markers play a crucial role in accurate diagnosis of myocardial necrosis and, more importantly, for assessing risk and directing appropriate therapy that improves clinical outcome. Development and utilization of biomarkers has evolved substantially over the past three decades. The earliest biomarkers, such as alanine aminotransferase and lactate dehydrogenase, have fallen out of use with the development of more sensitive and specific assays for creatine kinase isoenzyme MB and particularly cardiac troponin. Cardiac troponin T or I measurements are now considered surrogates for necrosis and myocardial infarction when elevated in the setting of acute cardiac ischemia. This chapter offers insight into evolution of cardiac biomarkers and offers thoughts regarding the future of necrosis biomarkers.

**Key Words:** Myocardial necrosis; lactate dehydrogenase; myosin light chains; aspartate aminotransferase; creatine kinase; CK-MB; cardiac troponin T; cardiac troponin I; myoglobin; heart-type fatty acid-binding protein; carbonic anhydrase III; acute coronary syndromes.

### INTRODUCTION

The homeostasis of healthy cells is disturbed when subjected to a supply-demand mismatch resulting in insufficient oxygen delivery, deprivation of nutrients, and decreased clearance of waste products. Acute cellular changes commonly include disruption of the

From: *Contemporary Cardiology:  
Cardiovascular Biomarkers: Pathophysiology and Disease Management*  
Edited by: David A. Morrow © Humana Press Inc., Totowa, NJ

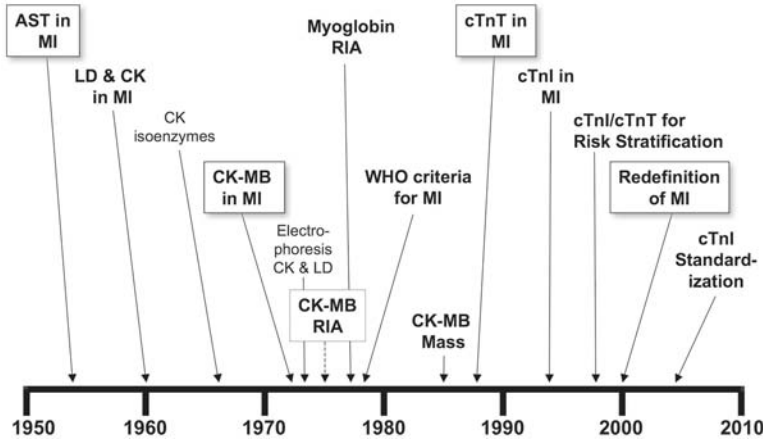


**Fig. 1.** Progression of myocyte changes with transition from reversible to irreversible injury during myocardial ischemia.

sodium-potassium pump, leakage of excess calcium into the cell, depletion of energy reserves, and conversion from aerobic to anaerobic cellular metabolism (1). If the mismatch is prolonged, ultrastructural cellular damage becomes irreversible, resulting in cell death and necrosis. Cells of tissues differ in their susceptibility and response to a metabolic mismatch. Figure 1 shows the progression of cellular changes for myocardial cells during persistent ischemia, the transition from reversible to irreversible injury, and cell death after approx 30 min to 1 h (1). Release of necrosis biomarkers occurs thereafter in the general time frames indicated in Fig. 1.

Although a cellular mismatch in supply vs demand can be caused by a number of physiological events, the root cause of most acute coronary syndromes (ACSs), a continuum of cardiac ischemia from unstable angina through myocardial infarction (MI), is plaque instability, plaque rupture, and occlusive intracoronary thrombus formation. Coronary occlusions causing ischemia damage not only myocytes but also arterioles in a process that is thought to hinder microvascular flow by increasing distal vascular resistance, stimulating arteriolar spasm, and causing endothelial dysfunction (2). Downstream from the organized occlusion, platelet microemboli are believed to shower the microcirculation, causing microvascular obstruction that further limits tissue perfusion, particularly if the epicardial infarct-related artery is recanalized (3). Microvascular dysfunction also occurs in non-infarct-related vessels, suggesting that myocardial ischemia may stimulate global signaling of an inflammatory response through a complex process with several interrelating stimuli and factors including the release of cytokines (4). As such, thrombus formation and the resulting supply–demand mismatch are followed by a complicated cascade of events, the end point of which is myocardial ischemia and myocardial cell necrosis.

Biomarkers have provided important information for the clinical assessment of patients with suspected MI patients since the early 1950s. As displayed in Fig. 2, utilization of biomarkers has evolved substantially over the past 30–40 yr. Biomarkers were previously considered to be one of the three important variables, along with changes on the electrocardiogram (ECG) and clinical signs and symptoms, necessary for the diagnosis



**Fig. 2.** Evolution of cardiac biomarkers. MI, myocardial infarction; AST, aspartate transaminase; LD, lactate dehydrogenase; CK, creatine kinase; RIA, radioimmunoassay.

of MI as defined by the World Health Organization (WHO) in 1979 (5). The biomarkers cardiac troponin T (cTnT) and I (cTnI) are now designated as surrogates for necrosis and MI when elevated in the setting of acute cardiac ischemia, according to the consensus document of the European Society of Cardiology (ESC) and the American College of Cardiology (ACC) (6).

Although the ACS continuum includes unstable angina and reversible myocardial injury, we focus here on biomarkers of necrosis, offering insight into their evolution and, more important, conveying thoughts regarding the future of necrosis biomarkers.

### BACKGROUND: BIOMARKERS OF CARDIAC NECROSIS

#### *The Ideal Cardiac Biomarker*

Table 1 summarizes the ideal characteristics for biomarkers of cardiac necrosis. Although several biomarkers satisfy one or more of these criteria, no single marker has yet been identified that satisfies them all. cTnI and cTnT come closest to the ideal, their forte being exquisite myocardial specificity. No tissue other than heart has been documented as a source of cardiac troponin (7), and cTnT and cTnI are abundant in myocardial tissue and virtually absent in blood from healthy individuals (8,9). cTnT and cTnI are elevated for days to weeks after MI. On the other hand, cTnT and cTnI are structural proteins and, consequently, their release kinetics are relatively slow, requiring 4–6 h after the acute event for the detection of elevated levels with high diagnostic sensitivity (9). In addition, accuracy in predicting cardiac troponin release patterns is complicated and varies among patients. Although most experts agree that cardiac troponin is released only with cardiac necrosis and not with reversible ischemia, increases in cTnI and cTnT occur in conditions other than MI (7). Furthermore, methods for measuring cardiac troponin yield heterogeneous results (10). Thus, there are several issues that preclude cardiac troponin from being the “holy grail” of diagnostic tests for myocardial necrosis. Despite these caveats, cardiac troponin is currently the cornerstone for evaluating myocardial necrosis in patients with signs and symptoms of cardiac ischemia. Table 2 summarizes important characteristics of available and developing biomarkers of cardiac necrosis.



Table 1  
Ideal Characteristics of Cardiac Necrosis Biomarkers

- 
- *Absolute cardiac specificity*: Biomarkers should not be present in noncardiac tissues under any physiological or pathological conditions.
  - *Specific for irreversible injury*: Biomarkers must differentiate reversible (ischemia) from irreversible (necrosis) injury.
  - *Early release*: Biomarkers should be released shortly after necrosis. Lower molecular-weight biomarkers generally have faster release kinetics. Release kinetics of soluble cytoplasmic biomarkers is theoretically faster than that of structural biomarkers.
  - *High tissue sensitivity*: Biomarkers should be abundant in cardiac tissue and absent in blood under all pathological conditions except necrosis. Biomarker release should be robust.
  - *Stable release*: To allow suitable detection, biomarkers should persist in circulation for hours to days following the acute necrotic event.
  - *Predictable clearance*: Clearance kinetics should be dynamic; predictable, to allow modeling; and unaffected by comorbidities such as renal insufficiency or hepatic injury. Predictable clearance also allows detection of recurrent events such as reocclusion and assessment timing of the necrosis event.
  - *Complete release*: Myocyte release should be complete. Release should be in direct proportion to the extent of necrosis (infarct sizing).
  - *Measurable by conventional methods*: The nature of the biomarker should allow quantitative measurement by reliable, rapid, precise, and cost-effective methodology that is readily available.
- 

### “Activity” vs “Mass” Measurements

The terms *activity* and *mass* are frequently used to describe biomarker assays. Activity measurement refers to biomarker quantification based on functionality, and results are usually reported in terms of international units per liter. In this context, activity assays often measure the ability of an enzyme cardiac biomarker to catalyze chemical conversion of a substrate reagent into a product under defined conditions such as temperature and pH. Quantitation is possible by monitoring formation of the product or depletion of substrate reagent. The fundamental principle is that the greater the concentration of biomarker in a patient sample, the greater the proportionate change will be in the product or substrate.

Mass assays are direct measurements of the amount (or mass) of the biomarker. The term *mass* was coined because these assays are reported in terms of mass units such as nanograms per milliliter, milligrams per deciliter, grams per liter, or moles per liter. State-of-the-art immunoassays for cardiac biomarkers are all mass assays and, therefore, results are reported in mass units.

## NECROSIS BIOMARKERS OF THE PAST

### *Lactate Dehydrogenase Activity and Isoenzyme Fractionation*

Lactate dehydrogenase (LD) is a cytoplasmic enzyme that has relatively high activity in myocytes and also in other tissues including skeletal muscle, liver, kidney, platelets, and erythrocytes (11). Measurement of LD as a cardiac biomarker was performed as early as 1960 (Fig. 2); fractionation of LD isoenzyme components, originally performed in the 1970s by electrophoresis or column chromatography, was applied to improve cardiac specificity by separating out the five major LD isoenzymes, LD1–LD5. The LD1 and

**Table 2**  
**Properties of Biomarkers of Myocardial Necrosis<sup>a</sup>**

<i>Biochemical marker</i>	<i>Molecular mass (Daltons)</i>	<i>Cardiac specific?<sup>b</sup></i>	<i>Advantages</i>	<i>Disadvantages</i>	<i>Duration of elevation</i>	<i>Diagnostic performance/comments</i>
Myoglobin	18,000	No	High sensitivity and negative predictive value; useful for early detection of MI and reperfusion	Low specificity in presence of skeletal muscle injury and renal insufficiency; rapid clearance after necrosis	12–24 h	2–6 h after presentation: sensitivity: 90% (95% CI: 88–93%); specificity: 86% (95% CI: 85–87%); negative predictive value: 96%
H-FABP	15,000	+	Early detection of MI	Low specificity in presence of skeletal muscle injury and with renal insufficiency	18–30 h	Biomarker for detection of cardiac injury in acute coronary syndromes within 6 h of symptoms onset. Although a relatively small number of clinical studies have been performed to date (12 studies comprising a total of 2130 patients), all indicate that H-FABP performance was either similar to or better than myoglobin for the early diagnosis of AMI
CK-MB, mass assays	85,000	+++	Ability to detect reinfarction; large clinical experience; previous “gold standard” for myocardial necrosis	Lowered specificity in skeletal muscle injury	24–36 h	Two serial values above 99th percentile of control reference population in setting of ischemia is benchmark for myocardial necrosis

*(continued)*

Table 2 (Continued)

Biochemical marker	Molecular mass (Daltons)	Cardiac specific? <sup>b</sup>	Advantages	Disadvantages	Duration of elevation	Diagnostic performance/comments
CK-MB isoforms	85,000	+++	Early detection of MI	Lack of widespread availability/experience	18–30 h	Using a 2.6 IU/L CK-MB cutoff with a CK-MB <sub>2</sub> /CK-MB <sub>1</sub> ratio $\geq 1.5$ , a study of 1100 patients presenting with signs and symptoms of ACS showed a 6-h sensitivity and specificity for diagnosing MI that were 95.7% and 93.9%, respectively (34)
$\infty$ cTnT	37,000	++++	Tool for risk stratification; detection of MI up to 2 wk; high specificity for cardiac tissue	Not an early marker of myocardial necrosis; limited ability to detect reinfarction	10–14 d	Single value above 99th percentile of control reference population is surrogate of myocardial necrosis in setting of myocardial ischemia
cTnI	23,500	++++	Tool for risk stratification; detection of MI up to 7 d; high specificity for cardiac tissue	Not an early marker of myocardial necrosis; limited ability to detect reinfarction; no analytical reference standards	4–7 d	Single value above 99th percentile of control reference population is surrogate of myocardial necrosis in setting of myocardial ischemia

<sup>a</sup>Time of first increase for the markers was 1–3 h for myoglobin, 3–4 h for CK-MB mass, 3–4 h for cTnT, and 4–6 h for cTnI.

<sup>b</sup>+, modest cardiac specificity; ++, high cardiac specificity; +++, very high (absolute) cardiac specificity.

LD2 isoenzymes predominated in serum after MI, frequently in an LD1 > LD2 flipped pattern, whereas LD4 and LD5 predominated in patients with hepatic disease or skeletal muscle injury and LD2, LD3, and LD4 with involvement of platelets or lymphatic disease (11). Fractionation of LD, focusing on the LD1 and LD2 isoenzymes, was used as an aid for the diagnosis of MI into the 1980s.

Total activity of LD is a relatively late biomarker with concentrations generally increasing to above normal levels in 24–48 h after coronary occlusion, peaking in 3–6 d, and returning to normal in 8–14 d. The LD1 > LD2 flipped pattern is elevated earlier, at 10–12 h after MI, peaking in 2 to 3 d, and returning to normal within 7–10 d (11,12). Using the MI diagnostic criteria that was standard in the 1980s, an elevated LD1 level and a flipped ratio had a sensitivity and specificity of approx 75–90% (11,12).

Measurement of LD activity and LD1/LD2 isoenzyme fractionation allowed a prolonged retrospective diagnosis of MI, which was useful for assessment several days after the acute event. However, the advent of reliable assays for cardiac troponin rendered LD measurement and fractionation for the diagnosis of MI an anachronism (13). According to the recent ESC/ACC redefinition of MI, total LD activity and LD isoenzymes should not be used for the diagnosis of cardiac damage (6).

### *Myosin Light Chains*

The sarcomere is the basic building block of the contractile apparatus in both skeletal and cardiac muscle. Differences in contraction characteristics of cardiac and skeletal muscle led to the notion that there were different sarcomeric isoforms for the protein myosin in these tissues (14). Myosin consists of two heavy chains and two pairs of light chains termed *myosin light chain 1* (MLC1), with a molecular mass of 27 kDa, and MLC2, with a molecular mass of 20 kDa. The MLCs are structural proteins that modulate interaction between myosin and actin. Interest in MLC was stimulated by the development of antibodies that reportedly differentiated cardiac from skeletal muscle MLC (15). Although <1% of MLC is found in the cytosol, this compartment serves as a staging area for myosin synthesis. MLC from the cytosol is released into the circulation 3–6 h after acute necrosis and remains elevated for 10–14 d, as the structural component is gradually released after cell death; peak MLC concentrations occur after 4 d (16).

Cardiac MLC showed promise for risk stratification and as a biomarker of necrosis. Hillis et al. (17) measured cTnI, MLC1, and creatine kinase (CK)-MB mass at presentation and then 4, 8, 16, and 24 h later in 208 patients with chest pain without new ST-elevation. Both cTnI and MLC1 predicted the long-term outcome of patients with chest pain, and in this cohort MLC1 was a better predictor of mortality and nonfatal acute MI than the measurement of cTnI. Although MLC measurements were initially received enthusiastically by the cardiology and laboratory medicine communities (18,19), in the 1980s it was suspected and later verified that the apparent cardiac isoform of MLC is also produced by slow-twitch skeletal muscle, thus explaining the observed crossreactivity in some clinical samples (20). MLC measurements therefore fell out of favor compared with CK-MB and as assays for cardiac troponin were being developed.

### *Aspartate Aminotransferase*

Aspartate aminotransferase (AST) was among the earliest myocardial cell necrosis biomarkers utilized in the clinical laboratory (Fig. 2) (21). AST (or SGOT) is a member of the aminotransferases; such enzymes catalyze the conversion of amino acids into 2-oxo-acids

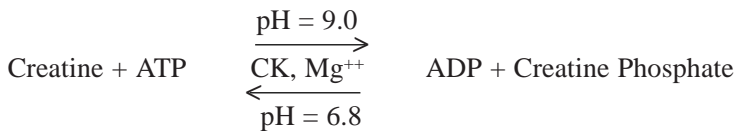
by transfer of amino groups. AST is abundant in skeletal muscle, liver tissue, erythrocytes, and myocardium (11). Distinct AST isoenzymes are present in the cytoplasm and mitochondria of cells; the half-life of the mitochondrial form is 10 d, vs the cytoplasmic form, which has a shorter half-life of only 10 h. Most experts agree that modest tissue injury causes release of the cytoplasmic isoenzyme, whereas more extensive damage results in release of the mitochondrial isoenzyme as well. The isoenzymes are not fractionated for clinical use.

AST is measured with activity assays. AST activity is normally present in serum, cerebrospinal fluid, and saliva but not in urine unless there is substantial renal injury. Heart tissue has high AST activity, but as stated, the enzyme is not specific for myocardial tissue. After MI, AST becomes abnormal in circulation within 6–8 h after the onset of symptoms, with peak values four- to fivefold higher than the upper limit of normal (ULN) reached after 18–24 h, and levels returning to normal within 4 to 5 d (12). Utilization of AST for diagnosis, monitoring, risk stratification, or other purposes in the context of MI is an anachronism because more sensitive and specific biomarkers have become available. According to the recent ESC/ACC redefinition of MI, AST should not be used as a biomarker to diagnose MI (6).

## NECROSIS BIOMARKERS OF THE PRESENT

### *CK: Total CK and the CK-MM, CK-MB, and CK-BB Isoenzymes*

Total CK comprises three major isoenzymes that catalyze the following reaction:



When cellular energy demands are relatively low and intracellular pH is approx 7.0, CK catalyzes the forward reaction with the formation of creatine phosphate. Creatine phosphate can be viewed as a storehouse for high-energy phosphate bonds that have been transferred from adenosine triphosphate (ATP). As indicated in the equation, CK also catalyzes the reverse reaction. When demands for energy in the cell increase, there is a rapid drop in intracellular pH caused by the local formation of acidic compounds, which induces CK to catalyze transfer of a high-energy phosphate bond from creatine phosphate to adenosine 5'-monophosphate (ADP), thus producing intracellular ATP in order to meet the increased energy demands.

CK is abundant in tissues that have periods of relative quiescence and then bursts of brisk activity or in cells subjected to differences in oxygen gradient. Expressed in terms of grams of wet tissue, total CK activity is highest in skeletal muscle, at 2500 U/g; heart has 473 U/g and brain has 55 U/g (11). A variety of other tissues such as the small intestine, tongue, diaphragm, uterus, and prostate also contain total CK activity, but in lower relative amounts (11). CK activity is virtually absent in most other tissues. Total CK tissue-to-plasma ratio is very high in skeletal muscle and somewhat high (albeit sevenfold less) in myocardium, conferring good performance as a biomarker, because dramatically increased plasma values are observed in association with increased muscle necrosis and trauma. Serum total CK concentrations are dependent on muscle mass, and average levels are higher in men than in women, higher in African Americans than in Caucasians, and higher in younger adults than in the elderly (11). In a study of marathon runners,

substantial increases in total CK levels were observed after extreme exercise, compared with prerace levels; concentrations returned to baseline in 4 d (22). There is no evidence that marathon running damages healthy, well-perfused myocardium, despite the fact that the plasma levels of total CK and other biomarkers may increase to the same as those measured after MI (23). However, these indices must be interpreted with caution for individuals who habitually undertake strenuous exercise, especially if they have done so within the previous week (23). Rhabdomyolysis also causes greatly increased serum total CK activity, as well as other skeletal muscle biomarkers such as myoglobin (11).

According to the ESC/ACC redefinition of MI, measurement of total CK is not recommended for the routine assessment of MI, because its wide tissue distribution confers lower diagnostic accuracy compared with other biomarkers (6). Some clinicians continue to measure total CK for epidemiological or scientific use, in which case the cutoff limit should be at least twice the ULN (6). Because the test is inexpensive and does not require specialized analyzers, as do other cardiac biomarkers, utilization of total CK for the diagnosis of MI may be reasonable in developing countries.

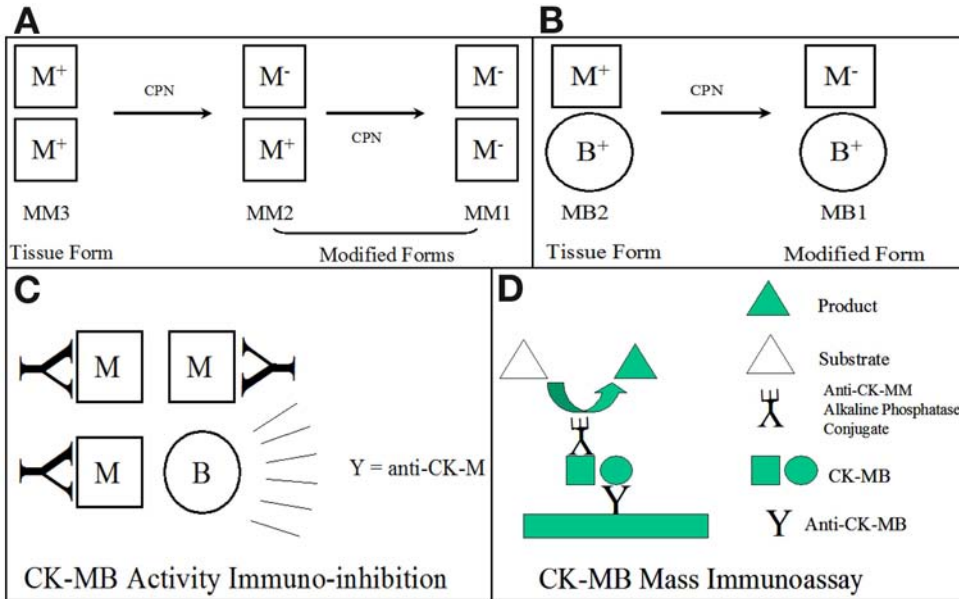
### ***CK-MB Isoenzyme***

Total CK activity represents the cumulative concentration of three CK isoenzymes. CK is a dimeric enzyme consisting of two types of subunits designated either “M,” originally for “muscle,” or “B” to connote “brain.” Each of these subunits is produced by a distinct gene (11). The nature of CK gives rise to three major isoenzymes: the two homodimers CK-MM and CK-BB and the heterodimer CK-MB (9). In patients with significant myocardial disease, i.e., aortic stenosis, coronary artery disease, or both, the CK-MB isoenzyme comprises approx 20% of the total CK in this tissue (24), whereas CK-MB comprises <3% of CK in skeletal muscle (25). Although healthy individuals may have a much lower percentage of CK-MB of 1.1% in their heart tissue (24), the far higher and consistently elevated CK-MB fraction in vulnerable patients with significant coronary heart disease confers excellent myocardial tissue specificity. CK-BB is found primarily in brain and intestinal tissue and contributes little to total CK activity; CK-BB is virtually absent from skeletal or cardiac tissue (25).

In skeletal muscle, usually >99% of the CK activity comprises the CK-MM isoenzyme (25). Although myocardium is the only tissue that has both a high proportion and high concentration of CK-MB, injury to skeletal muscle can compromise the diagnostic use of this biomarker because of the sevenfold higher total CK activity on a per-gram basis and the potential for the release of substantial CK-MB upon injury. Further, the body mass of skeletal muscle tissue is approx 100-fold greater than of myocardial muscle. To provide greater cardiac specificity using CK-MB, a CK-MB index may be calculated according to the following equation:

$$\text{CK-MB index} = 100\% (\text{CK-MB/Total CK})$$

CK-MB index values exceeding 2.5% are usually associated with a myocardial source of the MB isoenzyme (26); however, the index is reportedly as low as 2% and as high as 5%, depending on variability of both the numerator and denominator (27). A particular problem is posed by patients with both myocardial and skeletal muscle injury because CK-MB release from skeletal muscle may confound the diagnostic use of the CK-MB index by masking the relatively subtle CK-MB contribution from heart tissue and effectively “swamping” the denominator. It is also of note that elevations in both CK-MB concentration and CK-MB index have been attributed to skeletal muscle injury alone, with no



**Fig. 3.** (A) CK-MM isoforms. CK-MM3 consists of two unmodified tissue M subunits. On release into the circulation, carboxypeptidase N (CPN) hydrolyzes a terminal lysine at the C-terminus of each M subunit to generate the modified serum forms: MM2 (missing one lysine) and MM1 (missing two lysine residues, one from each polypeptide chain). Plus and minus signs represent the presence and absence of lysine residues, respectively. (B) CK-MB isoforms. Carboxypeptidase N (CPN) cleaves a lysine from the C-terminus of the M subunit of the MB2 (tissue isoform) and generates the MB1 (serum isoform). (C) Immunoinhibition of CK-MB activity. Anti-CK-M antibodies selectively bind to and inhibit the enzymatic activity of the CK-M subunits. The residual CK activity, measured by using total CK reagents, is the result of the B subunits of MB alone. To calculate the activity of the intact CK-MB isoenzyme, the residual result must be multiplied by a factor of two. (D) CK-MB mass immunoassay. Anti-CK-MB is immobilized on a solid matrix. CK-MB in the sample binds to the solid-phase antibody. Anti-CK-MM conjugate is added and binds to the antibody-CK-MB complex to form an antibody-CK-MB-antibody conjugate complex. The conjugate enzyme acts on the substrate to produce a colored product or fluorescence.

evidence of myocardial involvement (11). This pattern is infrequent, however, and overall CK-MB has been an excellent biomarker of myocardial injury over several decades.

### CK-MB ACTIVITY AND MASS ASSAYS

CK-MB measurements are considered highly selective for myocardium and in the 1970s became the standard for diagnostic assessment of MI (Fig. 2) (20). M subunits have a different charge relative to B subunits, and this difference in charge was used to fractionate total CK into serum CK-MM, CK-MB, and CK-BB isoenzymes using the principles of electrophoresis and ion-exchange column chromatography (28). Strategies based on measuring CK activity after separating out CK-MB were developed and used extensively from the late 1970s through the mid-1980s, when the first immunobased assays appeared in which antibodies were used to assess CK-MB activity. CK-MB activity assays used antibody reagents to inhibit activity of the M subunits of CK-MM and CK-MB (Fig. 3). Subsequently, total CK activity was measured, and assuming that CK-BB was negligible, all the activity remaining in the sample was attributed to the B subunit of CK-MB.

Results were multiplied by 2 to compensate for the activity of the inhibited M activity. These activity assays led to incorporation of CK-MB into updated criteria for the diagnosis of MI (29).

Although a very important contribution, CK-MB activity assays were and are limited by their inability to detect CK-MB at low concentrations. In addition, electrophoresis and column chromatography methods were subject to false-positive interference from so-called macro-CK, predominately caused by an immune response against CK-BB in some populations (11). Immunoinhibition assays were subject to interference from the presence of macro-CK as well as from any CK-BB in patient samples. For these reasons, CK-MB activity assays gave way to more analytically sensitive and specific mass immunoassays that offered the advantage of quantifying CK-MB as a specific protein, rather than relying on functional enzymatic activity as a surrogate. CK-MB activity assays have been replaced by CK-MB mass assays and by cardiac troponin; however, they are relatively inexpensive and, therefore, remain in use in some areas owing to economic conditions (6).

The earliest mass assay was a radioimmunoassay (RIA) that targeted the B subunit of CK-MB (30). This assay set the stage for the development of CK-MB-specific antibodies, the most widely used of which is the Conan antibody that is a component of many commercial assays in use today (31). Most mass assays are based on incorporation of two antibodies, one that captures the CK-MB in patient samples and another to which a signaling reagent is bound for detection (Fig. 3). In this way, a capture Ab-CK-MB-signal Ab sandwich is formed and detected. A standard dose–response curve is plotted using CK-MB standards from which the analytical concentration can be related to the mass of the CK-MB protein.

### CK-MB ISOFORMS

Myocardial tissue contains one CK-MB protein isoform. After release into the circulation after cell death, the M subunit of CK-MB from tissue undergoes posttranslational modification through cleavage of the C-terminal lysine by the blood enzyme carboxypeptidase-N (32). This modification forms a differently charged form of CK-MB, termed CK-MB<sub>1</sub>, that can be separated from the tissue form, termed CK-MB<sub>2</sub>, by electrophoresis (32). Studies characterizing the clinical performance of the isoforms of CK-MB isoenzymes (CK-MB<sub>1</sub> and CK-MB<sub>2</sub>) show promise for earlier identification of myocardial damage than assays of CK-MB alone. In homeostatic conditions, serum CK-MB<sub>2</sub>/CK-MB<sub>1</sub> ratios are approx 1.0, and total CK-MB concentration is <1.5 IU/L (33). Release of the CK-MB<sub>2</sub> tissue isoform into the circulation from damaged myocardial tissue increases the absolute level of CK-MB in the blood and also increases the ratio of CK-MB<sub>2</sub>/CK-MB<sub>1</sub>. The increased CK-MB<sub>2</sub>/CK-MB<sub>1</sub> ratio may be detected as early as 1 to 1.5 h after the onset of chest pain (33). The change in isoform ratio may precede significant elevations in CK-MB by up to 4 h, providing earlier identification of MI. Using a 2.6 IU/L CK-MB cutoff with a CK-MB<sub>2</sub>/CK-MB<sub>1</sub> ratio  $\geq$  1.5, a study of 1100 patients presenting with signs and symptoms of ACS showed values of 6-h sensitivity and specificity for diagnosing MI of 95.7 and 93.9%, respectively (34). Respective sensitivity and specificity for conventional 6-h CK-MB were reportedly 48.2 and 94% in this same population (34).

Automated processing for CK-MB isoforms is available, but interpretation can be technically challenging and the assay is available in only a few institutions. Both the National Academy of Clinical Biochemistry (35) and the ESC/ACC (6) have suggested consideration of myoglobin or CK-MB isoforms for use in the early diagnosis of myocardial injury.



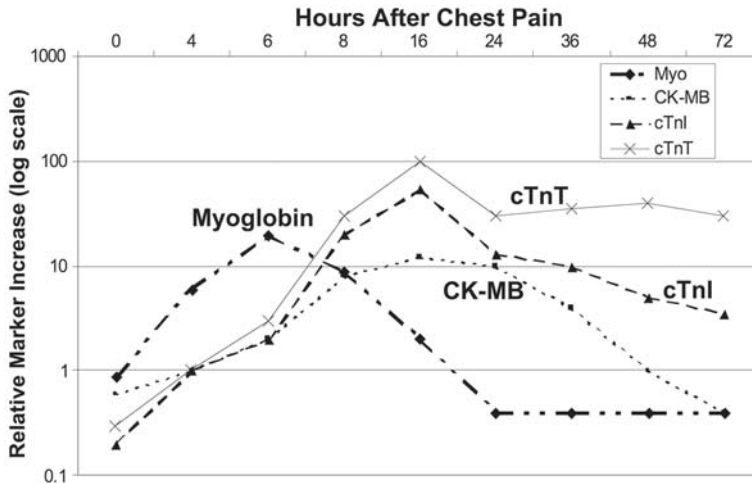


Fig. 4. Temporal release of myoglobin, CK-MB, and cTnT and cTnI.

#### CK-MB MASS FOR DIAGNOSIS OF MI

Figure 4 displays the biomarker release profile after MI. Release of CK-MB into the circulation occurs with the death of myocardial cells but does not occur with myocardial ischemia (36). In the past, CK-MB mass assays were considered the “gold standard” for the diagnosis of MI until reliable cardiac troponin assays became proven and widely available (37). The first rise in CK-MB following MI occurs 4–6 h after the onset of symptoms, but serial sampling over a period of 8–12 h is required for high sensitivity (6). Thus, despite excellent clinical performance, CK-MB is not an early marker and tissue specificity remains an issue in some cases. These assays are automated, have excellent detection limits ( $<1 \mu\text{g/L}$ ), are specific for CK-MB, and provide a rapid turnaround time (as short as 7 min). The American Association for Clinical Chemistry has proposed a recombinant CK-MB material for standardization of CK-MB mass assays (38).

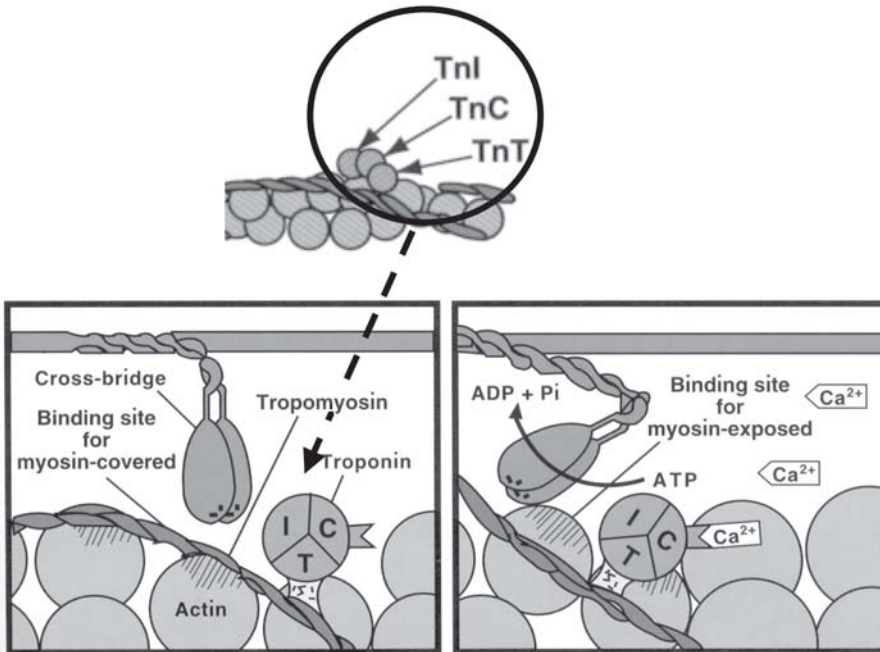
Measurement of CK-MB mass remains a sound tool for the evaluation of MI (6), but most healthy individuals have a measurable amount of CK-MB biological “background noise” in their blood, probably from skeletal muscle turnover. For diagnostic use, CK-MB release from myocardium (i.e., signal) must substantially exceed this noise, which renders CK-MB less diagnostically sensitive compared with cTnT or cTnI, for which the physiological background noise is virtually zero. The signal/noise difference between CK-MB and cardiac troponin is illustrated in Table 3, which shows an analysis of six cohorts that directly compares these biomarkers (39). In nearly 18,500 patients, measurement of cardiac troponin detected more MIs than did CK-MB in all six cohorts (range: +12 to +127%), with an overall increase of 14% more MIs diagnosed using cardiac troponin.

A meta-analysis focusing on the performance of CK-MB mass measurements in populations from emergency departments or inpatient cardiology units was conducted in 1995 and showed a diagnostic sensitivity of 96.8% (95% confidence interval [CI]: 95–98%) and a diagnostic specificity of 89.6% (95% CI: 87–92%) (40). However, this diagnostic performance is no longer accurate, because over the past decade it has become clear that even small amounts of necrosis, and the associated small release of cTnT and cTnI, identify patients at high risk of adverse events (41,42). Thus, cTnT and cTnI are the preferred markers, and CK-MB has been replaced as the “gold standard” for the diagnosis of MI (Table 2) (6). Nevertheless, many clinicians believe that measurements of CK-MB mass

**Table 3**  
**Portion of Positive Cardiac Troponin and CK-MB Results for Patients With Suspected MI From Five Databases<sup>a</sup>**

<i>No. of patients</i>	<i>Characteristics</i>	<i>Positive CK-MB (n [%])</i>	<i>Positive troponin (n [%])</i>	<i>Troponin/CK-MB (%)</i>
801	Acute myocardial ischemia	216 (27)	289 (36)	34
292	Possible myocardial ischemia	15 (5)	34 (12)	127
14,777	MI discharge diagnosis	4157 (28)	4661 (32)	12
1719	All ACS admissions	373 (22)	430 (25)	15
80	All ACS admissions except with ECG; diagnostic of MI	23 (29)	32 (40)	39
798	ACS admission to cardiology service	189 (23)	228 (28)	21
Total: 18,458	30.1% of populations diagnosed with MI	4973	5674	14

<sup>a</sup>Modified from ref. 39.



**Fig. 5.** Structure of troponin complex and contraction of striated muscle.

are still useful for timing the occurrence of MI, detecting reinfarction, and sizing the extent of infarction (35).

### *Cardiac Troponin*

#### **THE TROPONIN COMPLEX**

The troponin complex has three protein subunits and is located on the thin filament of striated muscle (Fig. 5). The three subunits are troponin T, a binding protein that attaches the troponin complex to tropomyosin; troponin I, which modulates the interaction of actin and myosin by acting as an inhibitor of actomyosin adenosine triphosphatase activity; and troponin C, the calcium-binding subunit of the troponin complex. After stimulation for contraction, excess calcium enters into cells and binds to troponin C. This binding causes a change in the conformation of tropomyosin, exposing the binding site on actin and actuating cross bridging; the result is muscle contraction. Troponin C has an identical amino acid sequence in both skeletal and cardiac tissues and, thus, has no potential as a cardiac-specific marker. However, troponin T and troponin I have different isoforms in cardiac and skeletal muscle, encoded by separate genes, and, consequently, have different amino acid sequences (9). The respective cardiac isoforms of cTnT and cTnI allow production of antibodies that exclusively recognize these myocardial-specific proteins. To date, cTnT and cTnI release has not been attributed to a tissue source other than myocardium, and except for rare analytical false positives, detection of cTnT or cTnI in the blood is indicative of heart injury (7).

#### **RELEASE AFTER NECROSIS**

cTnT and cTnI are structural biomarkers of cardiac necrosis whose kinetics require several hours after the onset of acute ischemia before they can be detected (Fig. 4). For this reason, cTnT and cTnI are not considered early biomarkers of necrosis. High diagnos-

tic sensitivity and specificity require specimen collection at patient presentation, 6–9 h later, and at 12–24 h if clinical suspicion is high and earlier results are negative (6). The increase in concentration of cTnI and cTnT after necrosis is prolonged compared with that of other biomarkers of necrosis (Fig. 4); this time course enables the diagnosis of MI many days after the acute event. The exact pattern of cTnT and cTnI release varies among individuals and is unpredictable; therefore, cTnT and cTnI may be less useful for assessing reocclusion or for infarct sizing compared to CK-MB mass (36).

### CIRCULATING FORMS

Although the nature of the troponin complex released after myocardial injury is not fully characterized, several reports suggest that a large portion of troponin I enters into the circulation first as TnC-cTnT-cTnI and cTnI-TnC complexes, with only a small portion of troponin I circulating in a free form (43,44). Studies have examined degradation of the cardiac troponins both inside the cell and in circulation (43,44). The release forms of cTnI and cTnT after degradation in circulation are incompletely understood at present but may have clinical importance. Currently, release of cTnT and cTnI and detection using commercially available assays is a surrogate for myocardial cell death in the setting of acute cardiac ischemia (6).

The International Federation of Clinical Chemistry (IFCC) Committee for Standardization of Cardiac Laboratory Markers developed specifications for the cardiac troponin assays (45).

### REDEFINITION OF MI: EVOLUTION WITH cTnT AND cTnI

The evolution of the definition of MI based on the availability of cardiac troponin is discussed in detail in Chapter 3. Initial regulatory clearance of cTnT and cTnI assays by the US Food and Drug Administration was based in large part on showing that their clinical performance was equivalent to CK-MB mass. This demonstration would have been straightforward had CK-MB mass and cTnT and cTnI indeed provided identical diagnostic information. However, the superior signal/noise biology for cardiac troponin yielded results that were diagnostically “positive” for cardiac troponin, but “negative” for CK-MB mass for many patients with ACS (39). A body of literature evolved for cardiac troponin over the past 5–10 yr, allowing meta-analysis (41,42) that unequivocally demonstrated that “positive” troponin results identify high-risk ACS patients, independent of the CK-MB results. In large part, these data motivated the redefinition of MI based on cardiac troponin as the preferred biomarker of cardiac necrosis (6).

### CLINICAL CUTOFFS

Selecting the appropriate decision point or cutoff that should be used for designating a positive cTnT or cTnI is a topic of controversy. Issues related to selection of decision limits are also discussed in other chapters. Several studies have found that even subtle increases in cTnT or cTnI are associated with increased risk of adverse cardiac events (46,47) and, therefore, a low cardiac troponin should be considered indicative of cardiac necrosis. The ESC/ACC consensus group recommended that the 99th percentile of a reference control population (i.e., normal value) should be utilized as the diagnostic cutoff (6). This cutoff is a much lower value than had been specified previously based on utilization of CK-MB as the predicate biomarker for MI diagnosis. The ESC/ACC group also specified that the imprecision of assays should have a coefficient of variation (CV) of 10% at the 99th percentile decision limit. This analytical goal was extremely ambitious and, in

fact, impractical for implementation, because only a few cardiac troponin assays could meet it (48,49). As a stopgap measure, some have suggested that the 10% CV of assays be utilized as the decision point, at least until assays are improved (50). Others have defined what may be considered an evidence-based approach in which a value conferring high risk is utilized as the decision point, regardless of the CV at that decision point (47). For epidemiological purposes, the AHA Council for Epidemiology and Prevention defines a positive biomarker as being at least one value above the 99th percentile of the distribution in healthy populations or the level at which a 10% CV can be demonstrated for a particular laboratory (39). This definition is contingent on at least two measurements at least 6 h apart (39). The values at the 99th percentile and the level of 10% CV for the majority of available assays for troponin are provided in Chapter 2, Fig. 9. It is critical that laboratory medicine and clinical staff collaborate on the choice and implementation of cardiac troponin assays, as well as on the cut point utilized. This issue is vital because of the heterogeneous quality of cardiac troponin assays, as was demonstrated by significant outcome differences among troponin assays even when the same apparent cutoff was utilized (51).

Harmonization (i.e., ensuring that *different* assays will yield the same cTnI results in patient specimens) has not yet been achieved. Although the *same* assay applied repeatedly to the same sample will yield similar results, cTnI results for the same patient but measured with *different* assays may vary by more than 30-fold (10). This phenomenon is the result of manufacturers using antibodies that target different epitopes of cTnI as well as using different calibrators. The situation for cTnI may be resolved, in part, through ongoing efforts to define a reference material and harmonize cTnI methods (52,53).

## *Myoglobin*

### FUNCTION AND RELEASE

Myoglobin is a heme protein that is abundant in the cytoplasm of cardiac and skeletal muscle cells; its function is to transport intracellular oxygen (9). The tissue/plasma ratio of myoglobin is very high and, thus, when necrosis of these tissues occurs, blood levels of myoglobin increase rapidly (Fig. 4). Myoglobin is generally accepted as the earliest appearing biomarker that is routinely available for assessment of patients with ACS. Myoglobin is released only upon necrosis, as evidenced by overall poor performance as a biomarker of acute cardiac ischemia (54). The earliest methods for measuring myoglobin were based on RIA (55). These assays had good performance but were untenable for routine use, because they used radioisotopes and required several hours for incubation. In the early 1990s, two-site immunoassays became available; with these assays, good performance and rapid turnaround times in a range of 10–15 min are possible, and these assays now predominate in laboratories (56).

The amino acid sequence for myoglobin is the same for both cardiac and skeletal muscle, so elevations are not exclusive for injury to either tissue. Myoglobin is cleared by the kidneys and, therefore, renal insufficiency causes elevated blood levels in the absence of acute tissue injury. For these reasons, myoglobin measurements are viewed as having low diagnostic specificity for myocardial injury. Myoglobin assays are in the process of being standardized and harmonized by a committee of the IFCC (57).

### CLINICAL USE FOR DIAGNOSIS OF MI

There is divergence as to whether myoglobin measurements are useful for the evaluation of patients with suspected ACS. Meta-analysis has shown that the clinical sensitivity of myoglobin is approx 90% with serial sampling and, somewhat surprisingly, about the

same for diagnostic specificity in the emergency medicine population (54). Nonetheless, suboptimal specificity is considered to limit the use of myoglobin as a biomarker to rule in MI. The diagnostic sensitivity of the biomarker, however, has led to recommendations by the National Academy for Clinical Biochemistry and the ESC/ACC that the biomarker is useful as an early marker (6,35). Perhaps the most useful application of myoglobin is to rule out myocardial necrosis with a negative predictive value approx 96% (54). Owing to myoglobin's kinetics, patients presenting relatively late after their acute event (e.g., >30 h) may have falsely negative values within the normal reference interval (Fig. 4). Therefore, cardiac troponin and perhaps CK-MB should always be assessed in combination with myoglobin.

In an attempt to improve sensitivity for the detection of MI, investigators have focused on the brisk increase in myoglobin after cardiac injury. These efforts have given rise to strategies in which differences between measurements at presentation and 60 to 120 min later are compared as an early indicator of MI (54,55). Most of these strategies use a doubling in myoglobin values over the early hours as the diagnostic criterion (58,59). Evidence shows that this use of myoglobin is open to question, however. A recent study comparing the "delta" strategy for myoglobin with a similar approach using CK-MB mass indicates that the CK-MB strategy is more sensitive for the diagnosis of MI (60).

Although utilization of myoglobin may add little as a diagnostic tool, several studies have suggested that elevated levels of myoglobin are significantly and independently associated with adverse outcomes (61,62).

### *Quantitative vs Qualitative Biomarker Testing*

Although the results of cardiac biomarker measurements are continuous values, the clinical assessment of myocardial necrosis typically is based on specific cut points. This dichotomization of cardiac biomarker results provides a context in which qualitative testing (i.e., positive vs negative) is clearly feasible, particularly for evaluation of the earliest specimen(s) as long as the appropriate cut point is used. In fact, a strategy for qualitative reporting of cardiac troponin may be most appropriate because quantitative assays may vary by up to 30-fold (10). Furthermore, qualitative testing (positive/negative) may help avoid discord between point-of-care testing and quantitative testing in the main laboratory, particularly when different technologies are used in these locations. Qualitative testing is less feasible for biomarkers that have different cut points that vary with race, gender, and/or age.

The key to successful qualitative testing is that the true biomarker concentration representing a positive result must be in harmony with the positive cut point for the qualitative assays used at an institution. When using both quantitative and qualitative assays, the cutoffs must be clinically evaluated to ensure that there is no discord in results between the methods. Discord will result in false-positive and false-negative results, leading to confusion (and understandable consternation) among clinical staff.

Quantitative assays are necessary for monitoring the release (rise) and clearance (fall) of cardiac markers. Applications other than the diagnosis of MI, such as risk stratification, reperfusion monitoring, and assessment of prognosis, also require continuous data.

### *Serial Sampling*

To optimize performance, biomarkers of myocardial necrosis require serial sampling when the initial results are negative (6,63); the largest impact is on diagnostic sensitivity.

Serial sampling is necessary because in most cases myocardial-specific necrosis biomarkers, most notably cardiac troponin and CK-MB, require a few hours before their natural kinetics show a detectable response to clinical events (Fig. 4). To the extent possible, placing cardiac biomarkers in the temporal context of clinical signs and symptoms is critically important. Serial sampling at presentation, 6–9 h later, and after 12 h is recommended if the earlier results are negative and clinical suspicion remains high (6).

## NECROSIS BIOMARKERS STILL IN DEVELOPMENT

### *Heart-Type Fatty Acid-Binding Protein*

Fatty acid-binding proteins (FABPs) are low-molecular-mass proteins (~14,500 Daltons) that are abundant in the cytoplasm of striated muscle cells (64,65). FABPs specifically and reversibly bind long-chain fatty acids and appear to function as the principle vehicle for cytosolic transport of long-chain unesterified fatty acids. Myocardium and skeletal muscle contain the same isoform of FABP, termed heart-type FABP (H-FABP), but the content of this protein in skeletal muscle is only 10–30% of that found in cardiac muscle. The level of H-FABP in healthy donors is relatively low (2–6 µg/L) (66), and the biomarker has a very good tissue/plasma ratio.

Like myoglobin, H-FABP is released from the heart soon after the onset of infarction, and it has been proposed as an early marker for the diagnosis of MI (64,65,67). Plasma concentrations of H-FABP increase within 3 h after MI and return to the normal range within 12–24 h in individuals without renal impairment (68). Differing relative amounts of H-FABP and myoglobin in myocardial vs skeletal muscle tissue led to the notion that the ratio of myoglobin/H-FABP may confer myocardial specificity. In one study, the ratio of myoglobin/H-FABP was found to be different in plasma from patients with myocardial injury (at 4.5) compared with skeletal muscle damage, which was associated with very high ratio values, in the range of 20–70 (68). However, strategies to improve detection of myocardial injury by calculating ratios of myoglobin and H-FABP have not yielded a clear advantage over the measurement of H-FABP alone (69). Moreover, the tissue specificity of H-FABP is questionable in patients with renal failure or skeletal muscle injury. Although a relatively small number of clinical trials have been conducted to date, H-FABP appears to have similar or better performance than myoglobin.

### *Carbonic Anhydrase (III)*

Carbonic anhydrase (III) (CAIII) is a 28-kDa cytosolic protein located almost exclusively in type I (slow-switch) skeletal muscle. Preliminary experiments showed that myoglobin and CAIII are released from skeletal muscle in a 3:1 fixed ratio during cell injury (70). Because CAIII is not present in myocardium, combining serum CAIII and myoglobin measurements has been proposed to improve the specificity of myoglobin as an early diagnostic marker for MI (71,72). Both serum myoglobin and CAIII have been shown to increase in healthy subjects following vigorous exercise and in patients with neuromuscular disease. By contrast, patients with acute MI showed markedly elevated myoglobin with no concomitant elevation in CAIII. Several studies have confirmed that myoglobin and CAIII are released in a fixed ratio following exercise, showed no significant difference in the ratio for trauma patients, and demonstrated a significant elevation in ratio in the setting of MI (73). These data suggest that the myoglobin/CAIII ratio may be a useful diagnostic indicator of MI (70). There is enthusiasm by some manufacturers to combine myoglobin and CAIII, but no commercial product is yet available.

Table 4  
Relative Performance of Various Markers and Combined Model for Diagnosis of MI<sup>a</sup>

Analyte	Receiver operating characteristic area	Sensitivity at 92.5% specificity (%)	Specificity at 92.5% sensitivity (%)
BNP	0.718	18.1	31.4
Myoglobin	0.847	49.5	59.5
cTnI	0.907	83.5	42.0
CK-MB	0.926	78.1	59.9
Combined model	0.950	89.9	89.3

<sup>a</sup>Modified from ref. 78.

## FUTURE MARKERS OF MYOCARDIAL NECROSIS

Accurate recognition of myocardial necrosis is important for achieving an accurate diagnosis but, more important, for assessing risk and directing appropriate therapy that improves clinical outcome. Most investigators agree that future efforts in diagnostics and therapeutics should focus on that phase of myocardial ischemia during which injury is reversible so that myocardial salvage can be maximized. Multimarker strategies using established and new biomarkers for risk stratification and clinical decision making have potential for improving the outcomes of patients with ACS (74).

In the context of myocardial necrosis, cTnI and cTnT measurements are fundamental for the diagnosis of MI by definition (6). Therefore, identifying biomarkers that will improve the tissue specificity and clinical performance possible with cardiac troponin for MI is a significant undertaking. Advances based on the detection of specific patterns of degradation/modification of cardiac troponin that might improve the early detection of myocardial necrosis or provide information regarding the specific mechanism of myocardial injury would be extremely valuable. In addition, continued enhancements to the analytic performance of assays for cardiac troponin will enable reliable detection of necrosis at lower concentrations.

Two additional efforts may also improve the ability to detect and diagnose myocardial necrosis: proteomics and modeling decision aids. These areas are related, but decision aids will be broadened beyond biomarkers to combine objective clinical indicators such as classification of ECG findings, history, age, and gender.

### *Modeling Computer Aids*

The rationale behind the use of multiple marker strategies is that each biomarker provides independent and additive information for the diagnosis of MI and risk assessment. Biomarkers are continuous variables, yet diagnostic interpretation generally utilizes cut points that force data into a binary scenario. One notion that adds value to modeling the combination of markers is that biomarkers that have not crossed the decision threshold for “positive” may contain useful information. In addition, modeling approaches must yield a single straightforward output, rather than several results that must be combined by the user.

One early approach to modeling involved a multimarker strategy in the context of diagnosing MI utilizing myoglobin, CK-MB, cTnI, and B-type natriuretic peptide (BNP) measurements to develop a multivariable index function (75). This strategy was piloted in a cohort that included 210 patients with noncardiac chest pain and 105 patients with MI; all samples were collected within 10 h of the onset of symptoms (76). Table 4 shows



the diagnostic performance of each biomarker and that performance of the panel was substantially better than any of the biomarkers alone. However, there are numerous caveats with this study, including prevalence of disease, timing of samples, definition of MI, and quality of each component biomarker. Nevertheless, it is interesting that the data indicate promise for the concept of combining multiple markers and improving the ability to diagnose myocardial necrosis.

## CONCLUSION

Utilization of biomarkers for the assessment of myocardial necrosis has had a rich history that spans nearly half a century. The earliest biomarkers, such as AST and LD, have fallen out of use with the development of assays for CK-MB and particularly cardiac troponin. The current order of diagnostic value is cTnT or cTnI > CK-MB mass > CK-MB activity > total CK (6,39). Myoglobin must be considered a niche biomarker that may lack sensitivity for the diagnosis of MI in the future but appears to have value for risk stratification. The quality of assays for biomarkers varies substantially, so assay choice must be a collaboration between laboratory and clinical staff. The future will undoubtedly involve automated multimarker strategies that will aim not only at the diagnosis of MI, but also the probability of ACS. In addition, assessing risk of future events in addition to defining the diagnosis will be included in the new paradigm. Biomarkers are absolutely fundamental to the (re)definition and diagnosis of MI, but it must be noted that MI is a clinical diagnosis and that a setting of myocardial ischemia must be established.

## REFERENCES

1. Rubin E, Farber JL, eds. *Essential Pathology*, 2nd ed. JB Lippincott, Philadelphia, 1995.
2. Roe MT, Ohman EM, Maas ACP, et al. Shifting the open artery hypothesis downstream: the quest for optimal reperfusion. *J Am Coll Cardiol* 2001;37:9–18.
3. Topol EJ, Yadav JS. Recognition of the importance of embolization in atherosclerotic vascular disease. *Circulation* 2000;101:570–580.
4. Gibson CM, Ryan KA, Murphy SA, et al. Impaired coronary blood flow in nonculprit arteries in the setting of acute myocardial infarction. *J Am Coll Cardiol* 1999;34:974–982.
5. Nomenclature and Criteria for Diagnosis of Ischemic Heart Disease. Report of the Joint International Society and Federation of Cardiology/World Health Organization Task Force on Standardization of Clinical Nomenclature. *Circulation* 1979;59:607–609.
6. Alpert JS, Thygesen K, Antman E, Bassand JP. Myocardial infarction redefined—a consensus document of The Joint European Society of Cardiology/American College of Cardiology Committee for the redefinition of myocardial infarction. *J Am Coll Cardiol* 2000;36:959–969.
7. Jaffe AS. Elevations in cardiac troponin measurements: false false-positives: the real truth. *Cardiovasc Toxicol* 2001;1:87–92.
8. Voss EM, Sharkey SW, Gernert AE, et al. Human and canine cardiac troponin T and creatine kinase-MB distribution in normal and diseased myocardium: infarct sizing using serum profiles. *Arch Pathol Lab Med* 1995;119:799–806.
9. Christenson RH, Azzazy HME. Biochemical markers of the acute coronary syndrome. *Clin Chem* 1998;44:1855–1864.
10. Christenson RH, Duh SH, Apple FS, et al. Standardization of cardiac troponin I assays: round robin of ten candidate reference materials. *Clin Chem* 2001;47:431–437.
11. Moss DW, Henderson AR. Clinical Enzymology. In: Burtis CA and Ashwood ER, eds. *Tietz Textbook of Clinical Chemistry*. WB Saunders, Philadelphia, PA, 1999, pp. 617–721.
12. Lott JA, Stang JM. Serum enzymes and isoenzymes in the diagnosis and differential diagnosis of myocardial ischemia and necrosis. *Clin Chem* 1980;26:1241–1250.
13. Jaffe AS, Landt Y, Parvin CA, Abendschein DR, Geltman EM, Ladenson JH. Comparative sensitivity of cardiac troponin I and lactate dehydrogenase isoenzymes for diagnosing acute myocardial infarction. *Clin Chem* 1996;42:1770–1776.

14. Leger JJ, Elzinga M. Studies on cardiac myosin light chains: comparison of the sequences of cardiac and skeletal myosin LC-2. *Biochem Biophys Res Commun* 1977;74:1390–1396.
15. Khaw BA, Gold HK, Fallon JT, Haber E. Detection of serum cardiac myosin light chains in acute experimental myocardial infarction. *Circulation* 1979;58:1130–1136.
16. Mair J, Thome-Kromer B, Wagner I, et al. Concentration time courses of troponin and myosin subunits after acute myocardial infarction. *Coron Artery Dis* 1994;5:865–872.
17. Hillis GS, Zhao N, Taggart P, Dalsey WC, Mangione A. Utility of cardiac troponin I, creatine kinase-MB(mass), myosin light chain 1, and myoglobin in the early in-hospital triage of “high risk” patients with chest pain. *Heart* 1999;82:614–620.
18. Katus HA, Diederich KW, Hoberg E, Kubler W. Circulating cardiac myosin light chains in patients with angina at rest: identification of a high risk subgroup. *J Am Coll Cardiol* 1988;11:487–493.
19. Hoberg E, Katus HA, Diederich KW, Kubler W. Myoglobin, creatine kinase-MB isoenzyme, and myosin light chain release in patients with unstable angina pectoris. *Eur Heart J* 1987;8:989–994.
20. Rosalki SB, Roberts R, Katus HA, Giannitsis E, Ladenson JH, Apple FS. Cardiac biomarkers for detection of myocardial infarction: perspectives from past to present. *Clin Chem* 2004;50:2205–2213.
21. Ladue JS, Wroblewski F, Karmen A. Serum glutamic oxaloacetic transaminase activity in human acute transmural myocardial infarction. *Science* 1954;120:497–499.
22. Warhol MJ, Siegel AJ, Evans WJ, Silverman LM. Skeletal muscle injury and repair in marathon runners after competition. *Am J Pathol* 1985;118:331–339.
23. Young A. Plasma creatine kinase after the marathon—a diagnostic dilemma. *Br J Sports Med* 1984;18:269–272.
24. Ingwall JS, Kramer MF, Fifer MA, et al. The creatine kinase system in normal and diseased human myocardium. *N Engl J Med* 1985;313:1050–1054.
25. Tsung SH. Creatine kinase isoenzyme patterns in human tissue obtained at surgery. *Clin Chem* 1976;22:173–175.
26. Adams J III, Abendschein DS, Jaffe AS. Biochemical markers of myocardial injury. Is MB the choice for the 1990’s? *Circulation* 1993;88:750–763.
27. Keffer JH. Myocardial markers of injury evolution and insights. *Am J Clin Pathol* 1996;105:305–320.
28. Roberts R, Henry PD, Witteveen SA, Sobel BE. Quantification of serum creatine phosphokinase isoenzyme activity. *Am J Cardiol* 1974;33:650–657.
29. Tunstall-Pedoe H, Kuulasmaa K, Amouyel P, Arveiler D, Rajakangas A, Pajak A. Myocardial infarction and coronary deaths in the World Health Organization MONICA project: registration procedures, event rates, and case-fatality rates in 38 populations from 21 countries in four continents. *Circulation* 1994;90:583–612.
30. Roberts R, Sobel BE, Parker CW. Radioimmunoassay for creatine kinase isoenzymes. *Science* 1976;194:855–857.
31. Vaidya HC, Maynard Y, Dietzler DN, Ladenson JH. Direct measurement of creatine kinase-MB activity in serum after extraction with a monoclonal antibody specific to the MB isoenzyme. *Clin Chem* 1986;32:657–663.
32. Wevers RA, Delsing M, Klein Gebbink JA, Soons JB. Post-synthetic changes in creatine kinase isozymes. *Clin Chim Acta* 1978;86:323–327.
33. Puleo PR, Perryman MB, Bresser MA, Rokey R, Pratt CM, Roberts R. Creatine kinase isoform analysis in the detection and assessment of thrombolysis in man. *Circulation* 1987;75:1162–1169.
34. Puleo PR, Meyer D, Wathen C, et al. Use of a rapid assay of subforms of creatine kinase-MB to diagnose or rule out acute myocardial infarction. *N Engl J Med* 1994;331:561–566.
35. Wu AH, Apple FS, Gibler WB, Jesse RL, Warshaw MM, Valdes R Jr. National Academy of Clinical Biochemistry Standards of Laboratory Practice: recommendations for the use of cardiac markers in coronary artery diseases. *Clin Chem* 1999;45:1104–1121.
36. Ishikawa Y, Saffitz JE, Mealman RL, Grace AM, Roberts R. Reversible myocardial ischemic injury is not associated with increased creatine kinase activity in plasma. *Clin Chem* 1997;43:467–475.
37. Lee TH, Rouan GW, Weisberg MC, et al. Sensitivity of routine clinical criteria for diagnosing myocardial infarction within 24 hours of hospitalization. *Ann Intern Med* 1987;106:181–186.
38. Christenson RH, Vaidya H, Landt Y, et al. Standardization of creatine kinase-MB (CK-MB) mass assays: the use of recombinant CK-MB as a reference material. *Clin Chem* 1999;45:1414–1423.
39. Luepker RV, Apple FS, Christenson RH, et al. Case definitions for acute coronary heart disease in epidemiology and clinical research studies: a statement from the AHA Council on Epidemiology and Prevention; AHA Statistics Committee; World Heart Federation Council on Epidemiology and Prevention; the Euro-

- pean Society of Cardiology Working Group on Epidemiology and Prevention; Centers for Disease Control and Prevention; and the National Heart, Lung, and Blood Institute. *Circulation* 2003;108:2543–2549.
40. Wu AHB, Lane PL. Metaanalysis in clinical chemistry: validation of cardiac troponin T as a marker for ischemic heart diseases. *Clin Chem* 1995;41:1228–1233.
  41. Ottani F, Galvani M, Nicolini FA, et al. Elevated cardiac troponin levels predict the risk of adverse outcome in patients with acute coronary syndromes. *Am Heart J* 2000;140:917–927.
  42. Heidenreich PA, Alloggiamento T, Melsop K, McDonald KM, Go AS, Hlatky MA. The prognostic value of troponin in patients with non-ST elevation acute coronary syndromes: a meta-analysis. *J Am Coll Cardiol* 2001;38:478–485.
  43. Katrukha AG, Bereznikova AV, Filatov VL, et al. Degradation of cardiac troponin I: implication for reliable immunodetection. *Clin Chem* 1998;44:2433–2440.
  44. Wu AH, Feng YJ, Moore R, et al. Characterization of cardiac troponin subunit release into serum after acute myocardial infarction and comparison of assays for troponin T and I. American Association for Clinical Chemistry Subcommittee on cTnI Standardization. *Clin Chem* 1998;44:1198–1208.
  45. Panteghini M, Gerhardt W, Apple FS, Dati F, Ravkilde J, Wu AH. Quality specifications for cardiac troponin assays. *Clin Chem Lab Med* 2001;39:175–179.
  46. Kaul P, Newby LK, Fu Y, et al. Troponin T and quantitative ST-segment depression offer complementary prognostic information in the risk stratification of acute coronary syndrome patients. *J Am Coll Cardiol* 2003;41:371–380.
  47. Morrow DA, Cannon CP, Rifai N, et al. Ability of minor elevations of troponins I and T to predict benefit from an early invasive strategy in patients with unstable angina and non-ST elevation myocardial infarction: results from a randomized trial. *JAMA* 2001;286:2405–2412.
  48. Panteghini M, Pagani F, Yeo KT, et al. Evaluation of imprecision for cardiac troponin assays at low-range concentrations. *Clin Chem* 2004;50:327–332.
  49. Christenson RH, Cervelli DR, Bauer RS, Gordon M, Stratus CS. Cardiac troponin I method: performance characteristics including imprecision at low concentrations. *Clin Biochem* 2004;37:679–683.
  50. Apple FS, Wu AH, Jaffe AS. European Society of Cardiology and American College of Cardiology guidelines for redefinition of myocardial infarction: how to use existing assays clinically and for clinical trials. *Am Heart J* 2002;144:981–986.
  51. Venge P, Lagerqvist B, Diderholm E, Lindahl B, Wallentin L. Clinical performance of three cardiac troponin assays in patients with unstable coronary artery disease (a FRISC II substudy). *Am J Cardiol* 2002;89:1035–1041.
  52. Tate JR, Heathcote D, Koerbin G, et al. The harmonization of cardiac troponin I measurement is independent of sample time collection but is dependent on the source of calibrator. *Clin Chim Acta* 2002;324:13–23.
  53. Tate JR, Heathcote D, Rayfield J, Hickman PE. The lack of standardization of cardiac troponin I assay systems. *Clin Chim Acta* 1999;284:141–149.
  54. Balk EM, Ioannidis JP, Salem D, Chew PW, Lau J. Accuracy of biomarkers to diagnose acute cardiac ischemia in the emergency department: a meta-analysis. *Ann Emerg Med* 2001;37:478–494.
  55. Kubasik NP, Guiney W, Warren K, D'Souza JP, Sine HE, Brody BB. Radioimmunoassay of serum myoglobin: evaluation and modification of a commercial kit and assessment of its usefulness for detecting acute myocardial infarction. *Clin Chem* 1978;24:2047–2049.
  56. Zaninotto M, Pagani F, Altinier S, et al. Multicenter evaluation of five assays for myoglobin determination. *Clin Chem* 2000;46:1631–1637.
  57. Panteghini M, Linsinger T, Wu AHB, et al. Standardization of immunoassays for measurement of myoglobin in serum. Phase I: evaluation of candidate secondary reference materials. *Clin Chim Acta* 2004;341:65–72.
  58. Gornall DA, Roth SN. Serial myoglobin quantitation in the early assessment of myocardial damage: a clinical study. *Clin Biochem* 1996;29:379–384.
  59. Montague C, Kircher T. Myoglobin in the early evaluation of acute chest pain. *Am J Clin Pathol* 1995;104:472–476.
  60. Fesmire FM, Christenson RH, Fody EP, Feintuch TA. Delta creatine kinase-MB outperforms myoglobin at two hours during the emergency department identification and exclusion of troponin positive non-ST-segment elevation acute coronary syndromes. *Ann Emerg Med* 2004;44:12–19.
  61. de Lemos JA, Morrow DA, Gibson CM, et al. The prognostic value of serum myoglobin in patients with non-ST-segment elevation acute coronary syndromes: results from the TIMI 11B and TACTICS-TIMI 18 studies. *J Am Coll Cardiol* 2002;40:238–244.

62. Newby LK, Storrow AB, Gibler WB, et al. Bedside multimarker testing for risk stratification in chest pain units: the chest pain evaluation by creatine kinase-MB, myoglobin, and troponin I (CHECKMATE) study. *Circulation* 2001;103:1832–1837.
63. Newby LK, Christenson RH, Ohman EM, et al. Value of serial troponin T measures for early and late risk stratification in patients with acute coronary syndromes. The GUSTO-IIa Investigators. *Circulation* 1998;98:1853–1859.
64. Tanaka T, Hirota Y, Sohmiya K, Nishimura S, Kawamura K. Serum and urinary human heart fatty acid-binding protein in acute myocardial infarction. *Clin Biochem* 1991;24:195–201.
65. Kleine AH, Glatz JF, Van Nieuwenhoven FA, Van der Vusse GJ. Release of heart fatty acid-binding protein into plasma after acute myocardial infarction in man. *Mol Cell Biochem* 1992;116:155–162.
66. Wodzig KW, Pelsers MM, van der Vusse GJ, Roos W, Glatz JF. One-step enzyme-linked immunosorbent assay (ELISA) for plasma fatty acid-binding protein. *Ann Clin Biochem* 1997;34:263–268.
67. Tsuji R, Tanaka T, Sohmiya K, et al. Human heart-type cytoplasmic fatty acid-binding protein in serum and urine during hyperacute myocardial infarction. *Int J Cardiol* 1993;41:209–217.
68. Van Nieuwenhoven FA, Kleine AH, Wodzig WH, et al. Discrimination between myocardial and skeletal muscle injury by assessment of the plasma ratio of myoglobin over fatty acid-binding protein. *Circulation* 1995;92:2848–2854.
69. Ishii J, Wang JH, Naruse H, et al. Serum concentrations of myoglobin vs human heart-type cytoplasmic fatty acid-binding protein in early detection of acute myocardial infarction. *Clin Chem* 1997;43:1372–1378.
70. Sly WS, Hu PY. Human carbonic anhydrases and carbonic anhydrase deficiencies. *Annu Rev Biochem* 1995;64:375–401.
71. Vaananen HK, Syrjala H, Rahkila P, et al. Serum carbonic anhydrase III and myoglobin concentrations in acute myocardial infarction. *Clin Chem* 1990;36:635–638.
72. Brogan GX Jr, Vuori J, Friedman S, et al. Improved specificity of myoglobin plus carbonic anhydrase assay versus that of creatine kinase-MB for early diagnosis of acute myocardial infarction. *Ann Emerg Med* 1996;27:22–28.
73. Beuerle JR, Azzazy HM, Styba G, Duh SH, Christenson RH. Characteristics of myoglobin, carbonic anhydrase III and the myoglobin/carbonic anhydrase III ratio in trauma, exercise, and myocardial infarction patients. *Clin Chim Acta* 2000;294:115–128.
74. Morrow DA, Braunwald E. Future of biomarkers in acute coronary syndromes: moving toward a multi-marker strategy. *Circulation* 2003;108:250–252.
75. Anderson NL, Anderson NG. The human plasma proteome: history, character, and diagnostic prospects. *Mol Cell Proteomics* 2002;1:845–867.
76. Reynolds MA, Anderberg JM, Buechler KF, et al. A cardiac marker panel for the diagnosis of acute myocardial infarction. *Clin Chem* 2004;50:A22 (abstract).



# 2

---

## Analytical Issues for Clinical Use of Cardiac Troponin

---

*Alan H. B. Wu, PhD*

### CONTENTS

INTRODUCTION  
RELEASE OF TROPONIN AFTER MYOCARDIAL INJURY  
QUALITY SPECIFICATIONS FOR ANALYTIC ASSAYS  
AMI CUTOFF CONCENTRATIONS AND ASSAY IMPRECISION  
FOR TROPONIN  
CARDIAC TROPONIN CUTOFF FOR RISK STRATIFICATION  
PRE- AND POSTANALYTIC VARIABLES  
CONCLUSION  
REFERENCES

---

### SUMMARY

Guidelines jointly developed by the European Society of Cardiology and the American College of Cardiology have established cardiac troponin (T or I) as the biomarker of choice for the diagnosis of acute coronary syndromes (ACSs) and risk stratification of patients who present with ischemic symptoms suggestive of ACS. Despite these international guidelines, a number of analytic issues have slowed the acceptance and implementation of this test worldwide. Regarding precision, analytic sensitivity, and specificity, the performance of commercial assays is variable. Moreover, there is a lack of assay standardization for troponin I results among commercial assays. The release of a standard reference material should initiate the process of assay harmonization. It is important that clinicians be familiar with the analytic performance (i.e., level of 10% coefficient of variation) and appropriate cut points (99th percentile and/or evidence-based decision limits) for all troponin assays used (both laboratory-based and point of care) at their institution. In time, it is hoped that all troponin assays will be standardized and exhibit similar performance to each other, as is the case for the majority of other clinical laboratory analytes today.

**Key Words:** Troponin; imprecision; interference; harmonization; false positive.

From: *Contemporary Cardiology:  
Cardiovascular Biomarkers: Pathophysiology and Disease Management*  
Edited by: David A. Morrow © Humana Press Inc., Totowa, NJ

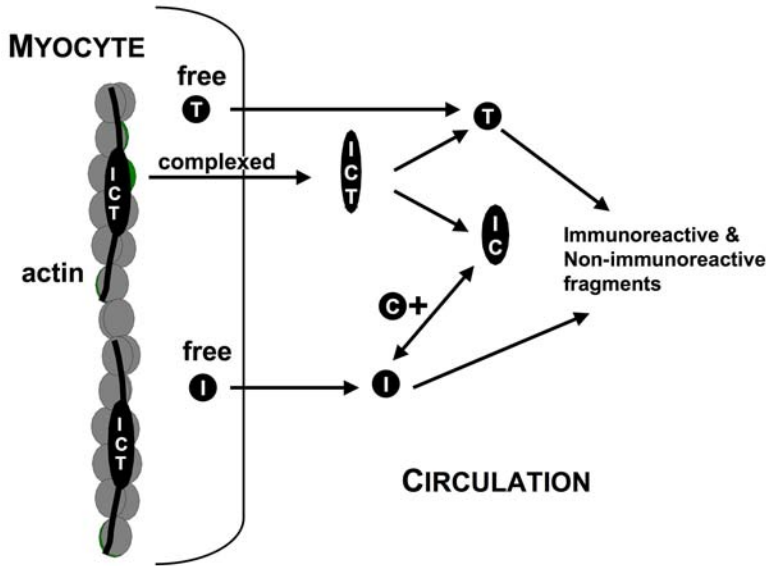
## INTRODUCTION

Guidelines that were jointly developed by the European Society of Cardiology (ESC) and the American College of Cardiology (ACC) have established cardiac troponin T (cTnT) or cTnI as the biomarker of choice for the diagnosis of acute coronary syndromes (ACSs) and risk stratification of patients who present with ischemic symptoms suggestive of ACS (1). Despite the international guidelines on the use of troponin by cardiologists, emergency department (ED) physicians, and clinical laboratory scientists (1–3), there are a number of analytic issues that have slowed the acceptance and implementation of this test worldwide. The performance of commercial assays is quite variable regarding precision, analytic sensitivity, and specificity. Furthermore, there is a lack of assay standardization for troponin I results among commercial assays. Recently, the National Institute of Standards and Technology (NIST) released a standard reference material that should initiate the process of assay harmonization. These problems in cardiac troponin have led to confusion as to the proper cutoff concentrations that should be used in routine clinical practice and in clinical trials. In addition, the reagent costs for cardiac troponin are higher than for other older markers such as creatine kinase (CK) and the CK-MB isoenzyme. In this chapter, these important issues are discussed with reference to their impact on the clinical interpretation of test results.

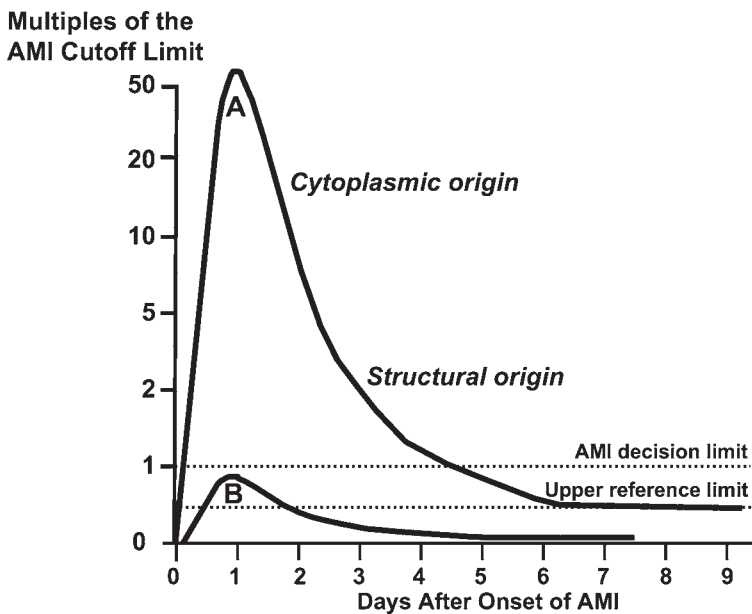
## RELEASE OF TROPONIN AFTER MYOCARDIAL INJURY

cTnT and cTnI are part of a complex of three regulatory proteins that includes troponin C. This ternary complex is bound to the thin filament of striated muscle and regulates the contraction of actin and myosin filaments. Following myocardial damage, the troponin T-I-C complex is gradually released into the blood, where it degrades into the binary I-C complex and free troponin T, the predominant forms of cardiac troponin in the circulation (Fig. 1) (4). In addition, a small amount of free troponin T and I exists within the cytoplasm and appears within the initial hours after the onset of cardiac damage (5). In Fig. 2, peak A illustrates the biphasic release pattern of cardiac troponin from damaged myocytes. Troponin I can also exist in phosphorylated forms and in oxidized/reduced forms. The degree of phosphorylation affects cardiac myocyte contractility in normal and failing hearts (6). Once in the blood, the various troponin forms undergo further degradation into smaller molecular weight fragments by serum proteolytic enzymes (see next section) (7).

An ongoing controversy is whether or not troponin can be released following reversible ischemia. Cardiac markers that are large in molecular weight, such as CK-MB (84 kDa) and lactate dehydrogenase (135 kDa), are released into the blood only after irreversible injury. However, some investigators have questioned whether cTnT and cTnI, at 37 and 24 kDa, respectively, can be released during ischemia (8,9). Although these proteins are themselves too large to traverse across viable cell membranes, studies have shown that troponin can undergo *in situ* degradation into smaller fragments during prolonged periods of myocardial ischemia (10). Using denaturing Western blot analysis, troponin fragments appear in the blood of patients with acute coronary syndromes within the first hour after the onset of chest pain, well before detection by commercial troponin assays (11). Others have suggested that the release of troponin following reversible injury is not likely (12). Although the debate is intellectually interesting, most agree that a definitive answer regarding this area of question will be difficult, if not impossible, to prove (13).

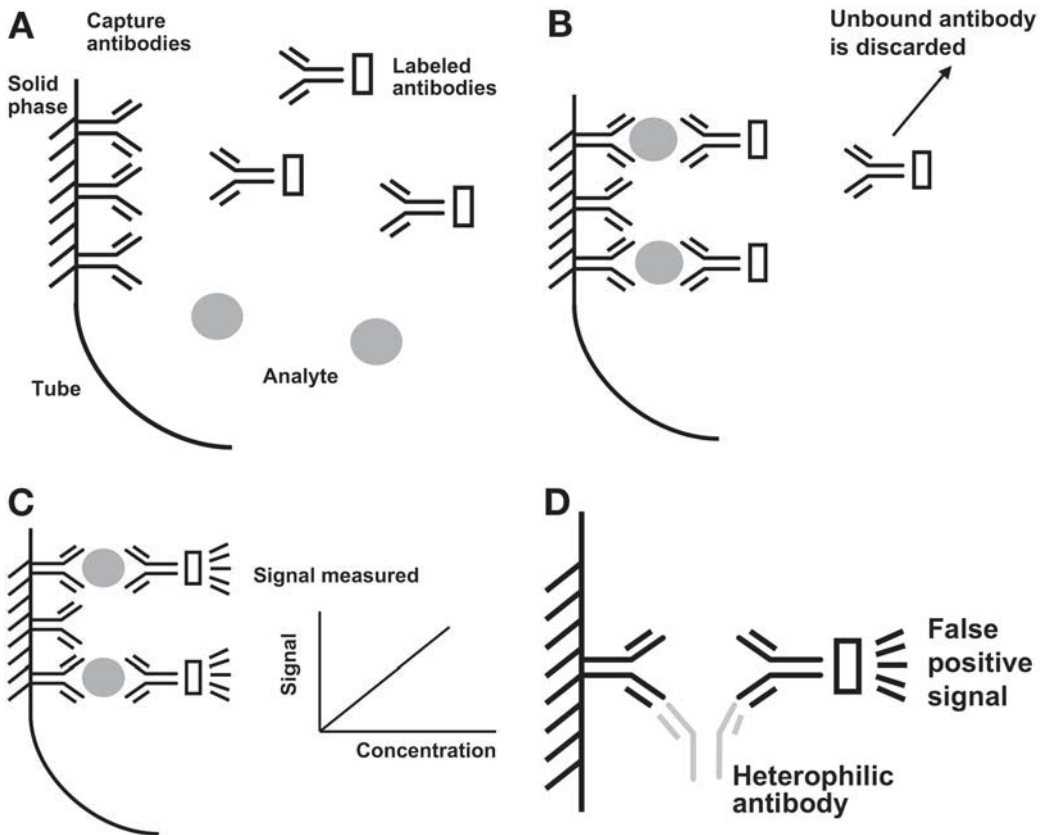


**Fig. 1.** The troponin T-I-C complex of the thin filament is released from damaged myocytes into various molecular forms. The T-I-C complex appears in the blood and degrades first into the I-C complex (the predominant form of cTnI in blood) and free TnT. The I-C complex further degrades into free troponin subunits and fragments of intact subunits (both immunoreactive and nonimmunoreactive). A small proportion of troponin I and T and fragments is also found in the cytoplasm. Troponin I can exist in either oxidized or reduced forms, or up to two phosphorylations.



**Fig. 2.** Biphasic release pattern of cardiac troponin and relationship of cutoff concentrations. Peak A, myocardial infarction (MI); peak B, unstable angina. AMI, acute myocardial infarction. (Modified from ref. 3.)





**Fig. 3.** (A) Two-site (“sandwich”) immunoassays. The capture antibody is immobilized to a solid surface (e.g., test tube wall). The detection antibody is labeled with a detecting enzyme, fluorophore, or chemiluminescent tag. (B) The presence of analytes (circles) enables capture. Unbound labeled antibody is removed. (C) The signal of the labeled antibody (left) is generated and measured. The concentration of the analyte is extrapolated from a calibration curve (right). (D) Mechanism for interferences owing to the presence of unusual antibodies. Heterophilic or human antimouse antibodies bind to both the capture and detection antibodies, producing an analytic signal in the absence of the analyte. (Modified from ref. 14).

## QUALITY SPECIFICATIONS FOR ANALYTIC ASSAYS

All assays for cardiac troponin require the use of immunoassay techniques. Two-site “sandwich” immunoassays make use of a capture antibody to bind to the analyte of interest, and a labeled antibody that is used to determine the quantity that is bound to the capture antibody (Fig. 3A–C). The concentration is determined from a calibration curve (plot of the analytic signal vs concentration of calibrators). An immunoassay analyzer is used to measure these proteins. Point-of-care (POC) testing devices offer an alternative to a large analyzer/central laboratory testing approach (*see* Chapter 32). Because the analytic performance of assays for cardiac markers can have a major impact on how results are interpreted, the International Federation of Clinical Chemistry Committee on Standardization of Markers of Cardiac Damage (IFCC C-SMCD) developed quality specifications for cardiac troponin assays (15). Table 1 summarizes the major recommendations made by this committee.

Table 1  
Quality Specification for Cardiac Troponin Assays

---

<i>Antibody specificity:</i> Antibodies in troponin assays should recognize the stable part of the molecule and should not be affected by complex formation or in vivo modifications.
<i>Calibration:</i> The natural and native troponin ternary complexes should be used.
<i>Sample dilution:</i> There should be no matrix effects for immunoassays, as determined by superimposable curves on dilution of high samples.
<i>Assay specificity:</i> There should be no crossreactivity with heterophilic, rheumatoid factor, or human antianimal antibodies.
<i>Documentation of preanalytic factors:</i> The types of blood collection tube and in vitro stability at different temperatures should be documented.

---

Adapted from ref. 36.

### *Epitope Specificity of Commercial Antibodies*

The performance of immunoassays is greatly dependent on the reactivity of the antibodies used toward the epitopes of the targeted proteins. Proper selection of antibodies is particularly important for troponin assays, because blood from patients with ACS contains a variety of different forms of troponin (Fig. 1). Whereas some assays produced an equimolar response to these forms, others produced a higher signal to the binary and ternary troponin forms (16). Thus, a tight linear regression of troponin I results from human patients was not achieved with a comparison of early commercial troponin assays (e.g.,  $r = 0.811$  for Beckman Access vs Stratus) (17).

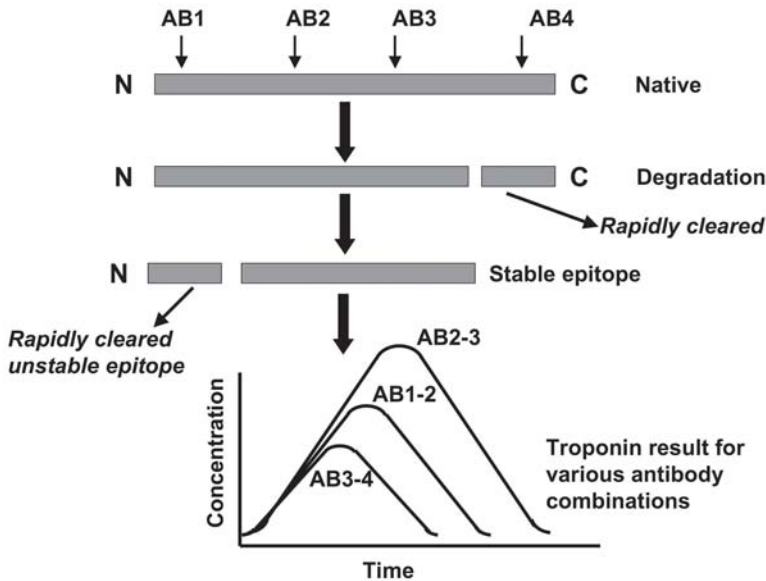
The primary sites of *in situ* and in vitro degradation for cTnT and cTnI are the C- and N-terminal sequences. These low-molecular-weight fragments are rapidly cleared from the circulation by glomerular filtration. As a consequence, assays that use antibodies directed toward the central stable portion of the molecule will exhibit greater relative increases in concentration over time and a longer duration of elevation (Fig. 4) (18). Antibodies directed toward the fragments will have a limited window of detectability. However, if troponin is released during reversible ischemia, development of assays directed to the N- and C-terminal fragments (the unstable parts of the molecule) may have added clinical utility.

### *Assay Standardization*

A major issue for cTnI assays is the current lack of industry standardization among commercial assays. Although this is not a problem for troponin T assay, because only one manufacturer (Roche) has the intellectual property rights for use of this test, it is an issue for other cardiac markers such as myoglobin and CK-MB (19).

#### CLINICAL IMPLICATIONS OF LACK OF STANDARDIZATION

Figure 5 illustrates the extent of the problem for cTnI regarding the lack of standardization. The data are from the College of American Pathologists 2004 Proficiency Survey (20). Although each of the commercial assays demonstrates linearity between individual concentrations and the zero point (demonstrating minimal *offset bias*), there is substantial *proportional bias* between assays, as recognized by the slope of each line against an arbitrarily selected predicate assay. Using results of assays that produce the lowest and highest cTnI results (Triage and AxSYM, respectively), the slopes differ by a factor of nearly 100 to 1, resulting in very different reported values for the same sample. For



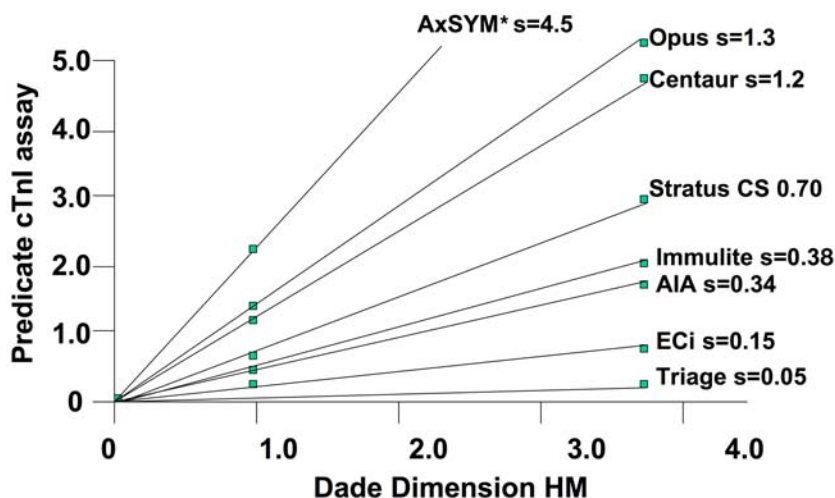
**Fig. 4.** Effect of antibody selection on measurement of cardiac troponin. (**Top**) Epitopes to four antibodies to the intact primary amino acid sequence of cTnI are shown. After troponin is released from the blood, it undergoes degradation at the C-terminal and then N-terminal sequences. These smaller peptides are rapidly removed from the circulation. (**Bottom**) Dual-site troponin assay using various combinations of antibodies. Assay AB3–4 shows a rapid return to baseline levels, owing to removal of the C-terminal fragment; assay AB1–2 shows an intermediate return to baseline, owing to removal of the N-terminal fragment; and assay AB2–3 shows a prolonged return to baseline, because the central portion of the peptide is the most stable.

example, for a sample reported as 1.0 ng/mL with the Dimension assay, results with other assays will vary from <0.2 with the Triage to >2.0 with the AxSYM. Table 2 provides the reasons for the lack of concordance between assays. The most influential reason is the fact that different manufacturers have used different calibrator materials and value assignment of calibrator concentrations.

The lack of assay standardization poses a major problem when interpreting results generated from different assays, such as when a patient is transferred from another hospital whose laboratory uses a different cTnI assay. Confusion may also occur if the same hospital uses different testing platforms, such as a POC assay when the patient is in the ED followed by a central laboratory assay when the patient is admitted to the coronary care unit. For risk stratification of patients with ACS, differences in cTnI cutoff concentrations make it very difficult to determine the proper cutoff concentrations for one assay when the published data from clinical studies use a different cTnI assay.

#### DEVELOPMENT OF REFERENCE MATERIAL FOR cTnI

To address the standardization issue, the American Association for Clinical Chemistry (AACC) established The Troponin I Standardization Committee (21). This committee obtained recombinant and heart-purified cTnI materials in the T-I-C and I-C complex forms, and free cTnI. Candidate reference materials (cRMs) were characterized for purity by liquid chromatography/mass spectrometry (LC/MS), and the cTnI concentrations were assigned by a combination of amino acid analysis and LC/MS. cRMs were evaluated to



**Fig. 5.** Lack of standardization for cTnI assays. Data are from the 2004 College of American Pathologists CAR-A Survey for Cardiac Markers (*see ref. 20*). Although each commercial assay (y-axis) demonstrates linearity for the two survey materials, they differ in the slope (“s”) of the line relative to the Dimension HM assay (arbitrarily selected as the predicate x-axis). \*First-generation assay, no longer available.

Table 2  
Reasons for Lack of Concordance Among Cardiac Troponin Assays

- Lack of standardization of the calibrating materials
- Differences in the specificity of the antibodies used in the assays
- Variability in the various forms of troponin found in blood and the reactivity of antibodies to these forms
- Differences in the analytic performance of assays with particular reference to analytic sensitivity and assay imprecision

determine whether they had acceptably low matrix-associated variations (“commutability”) when diluted in human serum or a suitable diluent selected by the manufacturer, and whether they could be used as calibrators to produce identical results for different cTnI assays (“harmonization”). To select the best material, each participating manufacturer of troponin I assays was given cRMs and instructed to calibrate their analyzers using these materials, and then measure serum pools prepared by the committee containing varying concentrations of cTnI. Based on three round-robin cycles of testing, the AACC standardization committee determined that the CIT ternary complex was most commutable. Using manufacturer-specified calibrations, results of the serum pools produced a variability of 90% among results of different assays. This variability was reduced by seven- to fivefold to 12% for these same assays when the cRM troponin CIT complex was used as a calibrator (22). The NIST has certified a Standard Reference Material based on the CIT complex (SRM #2921), and it is available at [www.nist.gov](http://www.nist.gov). One manufacturer (Abbott) has released an improved cTnI assay that is calibrated to the new NIST standard. Although other manufacturers have no obligation to use this material, many are in the process of reformulating their assays. The availability of a standard reference material will not enable complete standardization among assays, because of the variability of

epitopes targeted by antibodies used in the assays. However, results from individual patients using standardized assays will differ only by a small percentage, instead of orders of magnitude, as is the case today.

### *Assay Interferences*

All antibody-based assays are subjected to interferences owing to the presence of unusual antibodies such as heterophiles and human antianimal antibodies. As shown in Fig. 3D, these antibodies recognize and bind to antitroponin antibodies, thereby mimicking the analyte itself. Several case reports have documented this problem (23,24). There has been increasing attention by manufacturers of troponin I assays to reformulate their assays, but the incidence of false positive results has not been eliminated (25). Although less commonly encountered, false-negative results can also occur (26).

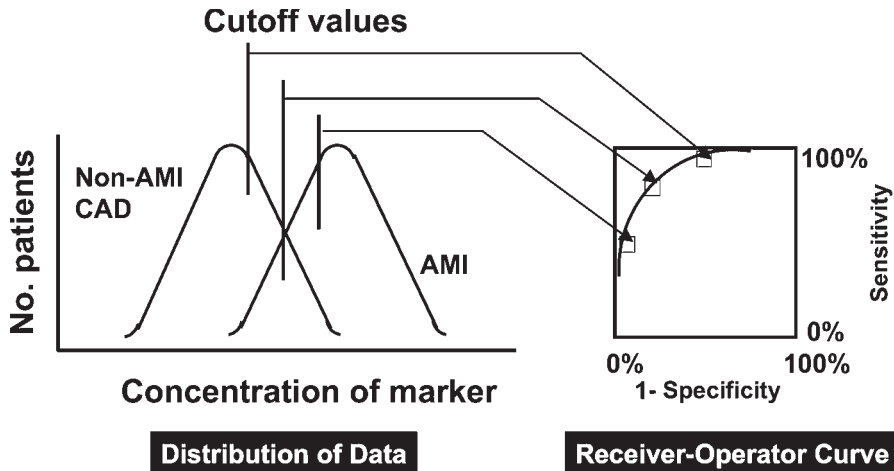
Repeated testing showing the absence of a rise and fall characteristic of acute myocardial injury can be very helpful in suggesting the presence of an interfering substance. Reversible interference such as that from fibrin strands resulting from incomplete isolation of serum ought to resolve completely with repeat testing using appropriate sample handling (e.g., centrifugation). Testing for heterophile antibodies may be conducted by a laboratory when an interfering antibody is strongly suspected.

### AMI CUTOFF CONCENTRATIONS AND ASSAY IMPRECISION FOR TROPONIN

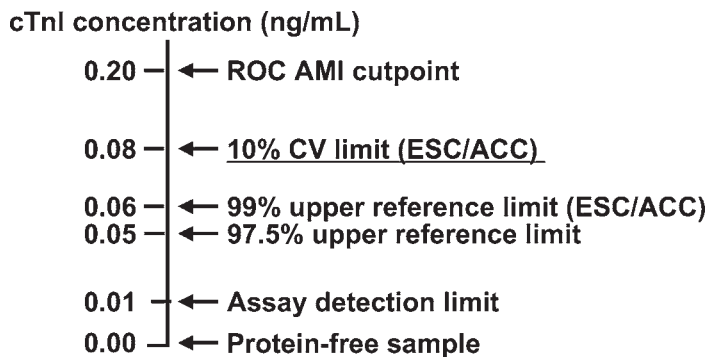
For the majority of clinical chemistry analytes, a reference range can be established, because the analyte is present in measurable concentrations in healthy individuals. The reference range is determined by measuring the analyte in a cohort of subjects who are free from the disease in question. Ideally, the healthy subjects should be matched to the targeted disease group regarding age, gender, race, and other factors. The reference range for two-tailed tests (i.e., clinical significance for both low and high results) is calculated by the mean  $\pm$  2 SDs if the distribution of results is parametric, or by the central 95% of results if the distribution is nonparametric. Because there is no significance for low cardiac marker results, the reference range can be computed as the upper 97.5% of healthy individuals using a one-tailed test.

In contrast to the majority of clinical chemistry analytes, cutoff concentrations for cardiac markers such as CK-MB and myoglobin were established on the basis of clinical criteria for the diagnosis of MI and not from a cohort of healthy individuals. Using receiver operating characteristic (ROC) curve analysis, which plots clinical sensitivity vs 1 – specificity, the optimum cutoff concentrations were determined at an analyte value that best discriminated between subjects with disease (i.e., AMI) and those without disease (Fig. 6). The latter category consisted of patients who presented to the ED with chest pain owing to a noncardiac etiology or who had cardiac disease that was not ruled out for AMI. Patients with unstable angina were considered to be in the non-AMI group, despite a minor increase in cardiac biomarker results. The cutoff concentrations were therefore higher than the 97.5% of a cardiac-healthy population.

The notion that biomarkers were only useful for diagnostic purposes changed with the demonstration that troponin was more sensitive than CK-MB for the detection of MI. Clinical trials showed that troponin could also be used for risk stratification of patients who were previously ruled out for AMI by the older biomarkers. The term *minor myocardial damage* was initially coined to refer to troponin concentrations that were between

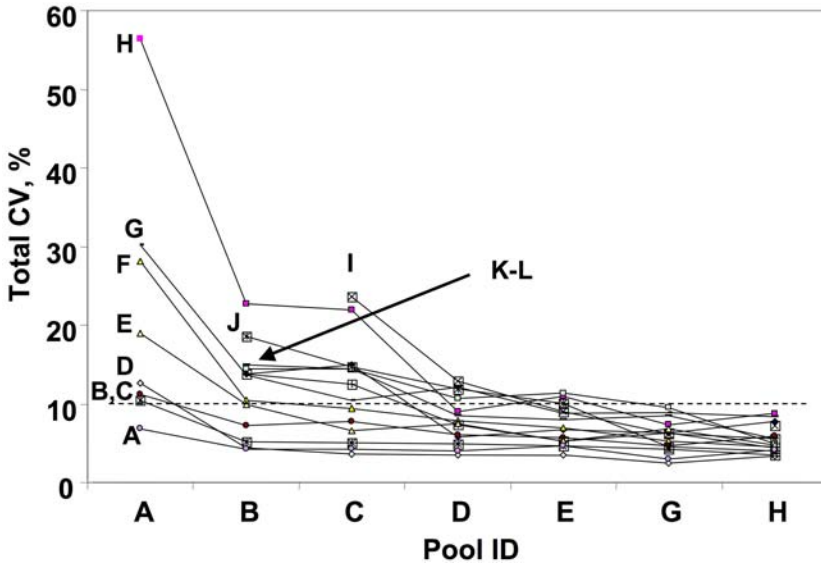


**Fig. 6.** ROC curve analysis plotted from distribution of cardiac marker results in disease vs a healthy population. CAD, coronary artery disease.

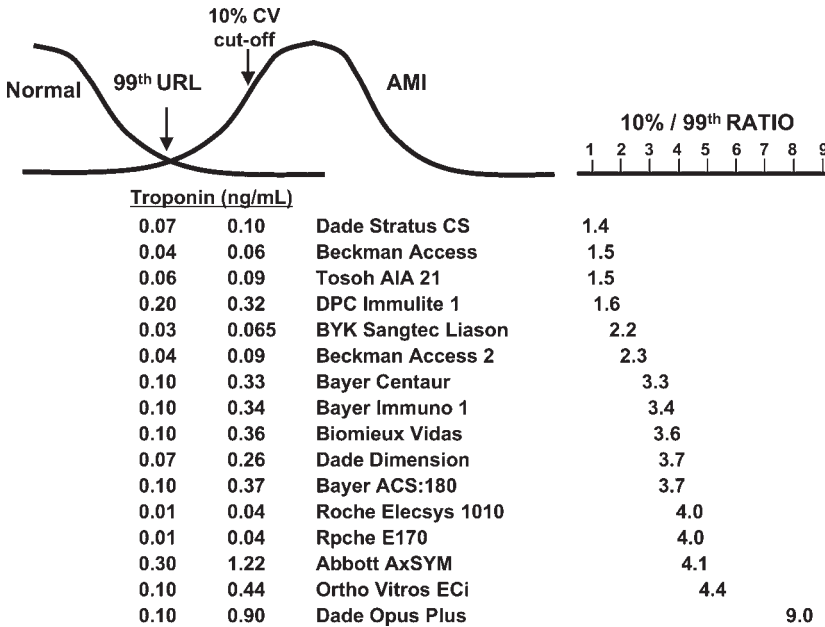


**Fig. 7.** Comparison of cutoff concentrations for cardiac troponin according to various criteria. (Adapted from ref. 27.)

the upper reference limit and the ROC-determined AMI cutoff concentration. Because cardiac patients with troponin concentration in this region were also shown to have a high incidence of poor outcomes, a joint committee of the ESC and ACC recommended lowering the cutoffs for cardiac markers to the upper 99% of healthy individuals (Fig. 7). Peak B in Fig. 2 shows that a patient with unstable angina may have a troponin concentration that is below the AMI decision limit but exceeds the upper reference limit of a healthy population. Use of this lower cutoff concentration posed a problem because most assays do not have the sensitivity to consistently detect troponin in the blood of healthy individuals and, therefore, the 99% cutoff could not be computed with any acceptable degree of analytic precision. Previously, the National Academy of Clinical Biochemistry had recommended that the assay imprecision be  $\leq 10\%$  at the cutoff concentration (2). A subcommittee of the ESC/ACC suggested that the AMI cutoff should be the marker concentration that first produces a 10% imprecision (coefficient of variation [CV]) (9) until new assays for troponin are developed with the necessary sensitivity. Figure 8 illustrates data for several commercial troponin I assays and the value and the concentration at the 10% CV level (28). Figure 9 compares the 99th percentile (obtained from the manufacturer's



**Fig. 8.** Imprecision vs analyte concentration profiles for cTnI. A: AIA21; B, C: Access and Access 2; D: Stratus CS; E: Centaur; F: Immulite; G: Dimension; H: ACS:180; I: Immuno 1; J: ECi; K: Liaison; L: Opus Plus; M: Vidas; N: AxSym; O: Alpha Dx. (Reproduced from ref. 28, with permission from the American Association for Clinical Chemistry.)



**Fig. 9.** Comparison of 99th percentile and 10% CV cutoffs for commercial cTnI assays. Data are taken from ref. 28. URL, upper reference limit.

package insert or personal communication from the manufacturer) to the 10% imprecision cut point (determined by the IFCC C-SMCD), and the ratio of the values for commercial cTnI assays. The smaller this ratio, the closer a particular assay is to achieving the goal of a CV  $\leq 10\%$  at the 99th percentile.

	A		B		C	
	ACS		ACS		ACS	
	Yes	No	Yes	No	Yes	No
cTn NEG	TN 450	FN 50	TN 810	FN 10	TN 890	FN 1
cTn POS	FP 50	TP 450	FP 90	TP 90	FP 10	TP 99
	900	100	500	500	900	100
	High Prevalence		Low Prevalence		High Accuracy	

**Fig. 10.** Bayesian statistics for cardiac troponin for 1000 hypothetical patients as function of disease prevalence and assay accuracy. (A) Prevalence of 50%, accuracy of 90%; (B) prevalence of 10%, accuracy of 90%; (C) prevalence of 10%; accuracy of 99%. TP, true positive; TN, true negative; FP, false positive; FN, false negative.

Regarding the definition of MI, the British Cardiac Society Working Group has recommended the use of two cutoff concentrations for cardiac troponin (29). The first, higher cutoff corresponds to “typical ACS clinical myocardial infarction,” using concentrations for cTnT (Roche) of >1.0 ng/mL and cTnI (Beckman Access 2) of >5 ng/mL. These troponin concentrations were selected because they approximate the traditional definition of AMI, including the use of total CK. The second cutoff concentrations are set at cTnT and cTnI concentrations below 1.0 and 0.5 ng/mL, respectively, and correspond to “ACS with myocyte necrosis.” These recommendations are in contrast to the ECS/ACC recommendations and illustrate and contribute to the ongoing debate over the redefinition of AMI guidelines (30–32).

### CARDIAC TROPONIN CUTOFF FOR RISK STRATIFICATION

Data from the TACTIC-TIMI 18 and FRISC-II trials have fueled debate regarding the optimum cutoff concentrations for cardiac troponin (33,34). These trials compared aggressive therapy such as with percutaneous intravascular intervention and dalteparin, respectively, against conservative treatment for patients with unstable angina. As predicted from previous studies, patients who had cardiac troponin levels above the 10% CV cut point had a higher 30-d death and MI rate than patients who had values below the upper limit of normal (99th percentile). However, patients who had troponin concentrations *between* the 99th percentile and the 10% CV cut point were also at increased risk for 30-d adverse events. For example, in the TACTICS-TIMI II Trial, the cTnI odds ratios for the 30-d death and AMI for unstable angina patients were 3.0 (95% confidence interval [CI]: 1.5–6.1) using the 10% CV cutoff, and 3.6 (95% CI: 1.8–7.3) using the 99th percentile cutoff (33). Similar findings were observed from the FRISC II Trial (34).

These data suggested that the lower (99%) cutoff concentration for cardiac troponin is the most appropriate for risk assessment in patients with a high clinical probability of ACS. Figure 10A shows that a test with a 90% accuracy produces a high ratio of true-positive to false-positive results when the prevalence of the tested population is high (e.g., 50%). However, when the prevalence for ACS is low (e.g., 10% for a general ED chest pain population), use of this same 90% accurate troponin assay will result in an unacceptably high false-positive rate (equal numbers of false positives and true positives) (Fig. 10B).



Thus, for a low disease prevalence population, the accuracy of the assay must be higher (e.g., to 99%, as shown in Fig. 10C) (35). Precision is an important attribute to *analytic* accuracy, because assays that are imprecise cannot be accurate. However, for use of troponin in ACS, if there is sufficient separation in troponin concentrations between low- and high-risk groups, the imprecision may have little effect on the *clinical* accuracy of the test.

## PRE- AND POSTANALYTIC VARIABLES

In addition to the analytic variables of assay performance, the quality of any laboratory data is also greatly dependent on pre- and postanalytic variables. Preanalytic variables include the types of blood collection tubes used and the time and manner by which specimens are transported to the laboratory. An important preanalytic variable is the stability of the analyte.

### *Collection of Samples*

Most commercial assays can accommodate either serum or plasma (anticoagulated with heparin or EDTA), but there are exceptions (e.g., only serum for Roche Elecsys cTnT, only heparinized plasma for Ortho ECi cTnI, and whole blood or EDTA plasma for Biosite Triage cTnI). The user should consult the clinical laboratory for specific blood collection details. For sample stability, troponin begins to degrade soon after blood is collected. Antibodies of most commercial assays today are directed to the stable or conserved portion of the protein and, thus, troponin instability is not a major issue with contemporary assays, especially because testing is usually conducted immediately after collection.

### *Turnaround Time*

Postanalytic variables include the overall turnaround time between ordering the test and reporting the results. Both cardiology and laboratory medicine groups recommend a turnaround time of 60 min for cardiac markers (3,33), although the ACC/American Heart Association state that a 30-min turnaround time is preferable. Meeting this lower figure would be very difficult for testing conducted in a central laboratory given the time required for sample delivery, centrifugation, and on-instrument analysis (typically 10–20 min). Increasingly, therapeutic management decisions are relying on the results of troponin tests. Unnecessary delays in either the pre- or postanalytic process reduce the usefulness of these tests.

The necessary turnaround time for cardiac marker results will be institution dependent. EDs with aggressive triage protocols (“chest pain centers”) are designed to make rapid therapeutic and/or management decisions and will benefit from rapid testing (e.g., turnaround time < 30 min) that can be delivered by the use of POC or near-patient (e.g., satellite) testing (see Chapter 32). EDs that have a more conservative triaging strategy may be able to justify testing from the central laboratory (turnaround time ~ 1 h), because patients are not triaged as quickly. The laboratory must work closely with ED physicians and cardiologists to deliver the needed turnaround times while maintaining cost-effectiveness.

## CONCLUSION

As with any laboratory test, the quality of the clinical information provided by that test is only as good as the analytic performance of the test itself. In the case of troponin, improvements in sensitivity and specificity are warranted. It is incorrect to assume that

all commercial troponin assays are the same. Under ideal conditions, a laboratory should select the best troponin assay that meets its clinical needs. However, clinical laboratories are often bound to contracts from specific manufacturers or vendors of laboratory equipment. Therefore, the assay most likely used in that institution is the one that is available on the instrument. It is important that the clinician be familiar with the analytic performance (i.e., level of 10% CV) and appropriate cut points (99th percentile and/or evidence-based decision limits) for all troponin assays used (both laboratory-based and POC) at his or her institution. It is hoped that in time all troponin assays will be standardized and exhibit similar performance to each other, as is the case for the majority of other clinical laboratory analytes today.

## REFERENCES

1. Joint European Society of Cardiology/American College of Cardiology Committee. Myocardial infarction redefined—a consensus document of the joint European Society of Cardiology/American College of Cardiology Committee for the redefinition of myocardial infarction. *J Am Coll Cardiol* 2000;36:959–969.
2. Fesmire FM, Decker WW, Howell JM, Kline JA. Clinical policy: critical issues in the evaluation and management of adult patients presenting with suspected acute myocardial infarction or unstable angina. *Ann Emerg Med* 2000;35:521–544.
3. Wu AHB, Apple FS, Gibler WB, Jesse RL, Warshaw MM, Valdes R Jr. National Academy of Clinical Biochemistry Standards of Laboratory Practice: recommendations for use of cardiac markers in coronary artery diseases. *Clin Chem* 1999;45:1104–1121.
4. Wu AHB, Feng YJ. Biochemical differences between cTnT and cTnI and its significance for the diagnosis of acute coronary syndromes. *Eur Heart J* 1998;19(Suppl N):25–29.
5. Katrukha AG, Bereznikova AV, Esakova TV, et al. Troponin I is released in bloodstream of patients with acute myocardial infarction not in free form but as complex. *Clin Chem* 1997;43:1379–1385.
6. Bodor GS, Oakeley AE, Allen PD, Crimmins DL, Ladenson JH, Anderson PA. Troponin I phosphorylation in the normal and failing adult human heart. *Circulation* 1997;96:1495–1500.
7. McDonough JL, Arrell DK, Van Eyk JE. Troponin I degradation and covalent complex formation accompanies myocardial ischemia/reperfusion injury. *Circ Res* 1999;84:9–20.
8. Wu AHB, Ford L. Release of biochemical markers in acute coronary syndromes: ischemia or only necrosis? *Clin Chim Acta* 1999;284:161–171.
9. Sobel BE, LeWinter MM. Ingenuous interpretation of elevated blood levels of macromolecular markers of myocardial injury: a recipe for confusion. *J Am Coll Cardiol* 2000;35:1355–1358.
10. Murphy AM, Kogler H, Geogakopoulos D, et al. Transgenic mouse model of stunned myocardium. *Science* 2000;287:488–491.
11. Labugger R, Organ L, Collier C, Atar D, Van Eyk JE. Extensive troponin I and T modification detected in serum from patients with acute myocardial infarction. *Circulation* 2000;102:1221–1226.
12. Carlson RJ, Navone AN, McConnell JP, et al. Effect of myocardial ischemia on cardiac troponin I and T. *Am J Cardiol* 2002;89:224–226.
13. Jaffe AS, Ravkilde J, Roberts R, et al. It's time for a change to a troponin standard. *Circulation* 2000;102:1216–1220.
14. Wu AHB. Analytical issues affecting the clinical performance of cardiac troponin assays. In: Adams JE, Apple FS, Jaffe AS, Wu AHB, eds. *Markers in Cardiology: Current and Future Applications*. Future Publishing Co., Armonk, NY, 2001.
15. Panteghini M, Gerhardt W, Apple FS, Dati F, Ravkilde J, Wu AH. Quality specifications for cardiac troponin assays. *Clin Chem Lab Med* 2001;39:174–178.
16. Wu AHB, Feng YJ, Moore R, et al. Characterization of cardiac troponin subunit release into serum following acute myocardial infarction, and comparison of assays for troponin T and I. *Clin Chem* 1998;44:1198–1208.
17. Christenson RH, Apple FS, Morgan DL, et al. Cardiac troponin I measurement with the ACCESS immunoassay system: analytical and clinical performance characteristics. *Clin Chem* 1998;44:52–60.
18. Katrukha AG, Bereznikova AV, Filatov VL, et al. Degradation of cardiac troponin I: implication for reliable immunodetection. *Clin Chem* 1998;44:2433–2440.
19. Christenson RH, Duh SH, Apple FS, et al. Standardization of cardiac troponin I assays: round robin of ten candidate reference materials. *Clin Chem* 2001;47:431–437.

20. College of American Pathologists. Cardiac marker CAR-A survey participant summary report. CAP, Northfield, IL, 2004; pp. 1–30.
21. Christenson RH, Duh SH, Apple FS, et al. Towards standardization of cardiac troponin I assays: assessing commutability of candidate reference materials and assay harmonization. *Clin Chem* 2005, submitted.
22. Fitzmaurice TF, Brown C, Rifai N, Wu AHB, Jeo KTJ. False increase of cardiac troponin I with heterophilic antibodies. *Clin Chem* 1008;44:2212–2214.
23. White GH, Tideman PA. Heterophilic antibody interference with CARDIAC T Quantitative Rapid Assay. *Clin Chem* 2002;48:201–203.
24. Yeo KT, Storm CA, Li Y, et al. Performance of the enhanced Abbott AxSYM cardiac troponin I reagent in patients with heterophilic antibodies. *Clin Chim Acta* 2000;292:13–23.
25. Mahalingam M, Ottlinger ME. False-negative qualitative cardiac troponin T in a 79-year-old man with myocardial infarction. *JAMA* 1997;278:2143, 2144.
26. Braunwald E, Antman EM, Beasley JW, et al. ACC/AHA guidelines for the management of patients with unstable angina and non-ST-segment elevation myocardial infarction: executive summary and recommendations. *Circulation* 2000;102:1193–1209.
27. Wu AHB. Analytical issues and the evolution of cutoff concentrations for cardiac markers. In: Wu AHB, ed. *Cardiac Markers*, Second Edition. Humana, Totowa, NJ: 2003.
28. Panteghini M, Pagani F, Yeo KT, et al. Evaluation of imprecision for cardiac troponin assays at low-range concentrations. *Clin Chem* 2004;50:327–332.
29. Fox KAA, Birkhead J, Wilcox R, Knight C, Barth J. British Cardiac Society Working Group on the definition of myocardial infarction. *Heart* 2004;90:603–609.
30. Richards AM, Lainchbury JG, Nicholls MG. Unsatisfactory redefinition of myocardial infarction. *Lancet* 2001;357:1635, 1636.
31. Jolobe OM, Tormey W, Birkhead JS, Norris RM. Redefinition of myocardial infarction. *Lancet* 2001; 358:764.
32. Norris RM. Dissent from the consensus on the redefinition of myocardial infarction [comment]. *Eur Heart J* 2001;22:1626, 1627.
33. Morrow DA, Cannon CP, Rifai N, et al. TACTICS-TIMI 18 Investigators. Ability of minor elevations of troponins I and T to predict benefit from an early invasive strategy in patients with unstable angina and non-ST elevation myocardial infarction: results from a randomized trial. *JAMA* 2001;286:2405–2412.
34. Venge P, Lagerqvist B, Diderholm E, Lindahl B, Wallentin L. Clinical performance of three cardiac troponin assays in patients with unstable coronary artery disease (a FRISC II Substudy). *Am J Cardiol* 2002; 89:1035–1041.
35. Wu AHB, Apple FS. Reporting of cardiac troponin concentration [letter]. *Clin Chem* 2002; 48:2077–2082.
36. Panteghini M, Gerhardt W, Apple FS, Dati F, Raukild J, Wu AH. Quality specifications for cardiac troponin assays. *Clin Chem Lab Med* 2001;39:175–179.

# 3

---

## Defining Myocardial Infarction

---

*Allan S. Jaffe, MD and Luciano Babuin, MD*

### CONTENTS

INTRODUCTION  
THE 1999 ESC/ACC DEFINITION  
TROPONIN IS THE BIOCHEMICAL MARKER OF CHOICE  
FOR THE DIAGNOSIS OF MYOCARDIAL INJURY  
DETECTION OF MYOCARDIAL DAMAGE  
MI IN SPECIFIC CLINICAL SETTINGS  
ADDITIONAL CONSIDERATIONS FOR CLINICAL USE  
CONCLUSION  
APPENDIX: APPLICATION OF ESC/ACC RECOMMENDATIONS  
TO CLINICAL TRIALS  
REFERENCES

---

### SUMMARY

The diagnosis of acute myocardial infarction (AMI) as defined by the World Health Organization (WHO) was based for many years on the presence of two of three possible criteria: clinical symptoms compatible with AMI, typical electrocardiogram changes, and increases in markers of cardiac injury. However, because of the very good sensitivity and specificity of creatine kinase-MB (CK-MB), it eventually became rare to diagnose AMI in the absence of elevations of this biomarker. Thus, although never formally embraced by WHO, the clinical diagnosis of AMI became dependent on elevation of a biomarker of myocardial injury in the appropriate clinical setting. This approach evolved further with the development of cardiac troponin and its integration into the definition of MI by the European Society of Cardiology and the American College of Cardiology. The present diagnostic standard for MI is thus based on the following biomarker criteria: Maximal concentration of troponin T or I exceeding the decision limit (99th percentile of the values for a reference control group) manifesting a dynamic pattern on at least one occasion during the first 24 h after the index clinical event; if the value is between the 99th percentile and the 10% coefficient of variation level, caution is warranted because analytic false-positive results can occur. In the unusual situation in which troponin assays are not available, the value of CK-MB (preferably CK-MB mass) exceeding the 99th percentile of the value for a reference control group and manifesting a dynamic pattern can be used for diagnosis.

**Key Words:** Troponin; myocardial infarction; diagnosis.

From: *Contemporary Cardiology:  
Cardiovascular Biomarkers: Pathophysiology and Disease Management*  
Edited by: David A. Morrow © Humana Press Inc., Totowa, NJ

## INTRODUCTION

For many years, the diagnosis of acute myocardial infarction (AMI) as defined by the World Health Organization (WHO) was based on the presence of two of three possible criteria: clinical symptoms compatible with AMI, typical electrocardiogram (ECG) changes, and increases in markers of cardiac injury (1). These criteria arose as early as 1959 from efforts of the WHO to develop a definition of AMI in order to track its prevalence and associated prognosis. Initially, only clinical symptoms and ECG changes were included as criteria (2). Subsequently, after work building on the initial description of biomarker increases in AMI (3), markers of myocardial necrosis were added as secondary criteria. Because of the poor specificity of the available markers, the lack of standardized assays, and the lack of adequately derived normal ranges, locally determined biomarker criteria were used and high thresholds suggested (1,4). However, with the important work of Sobel and colleagues and additional time, first total creatine kinase (CK) and subsequently CK-MB became the “gold standard” biomarkers for the definition of cardiac injury (5–9). Because of the very good sensitivity and specificity of CK-MB, eventually it became rare to diagnose AMI in the absence of elevations of this biomarker. Thus, although never formally embraced by WHO, the clinical diagnosis of AMI became dependent on elevations of this marker of myocardial injury in the appropriate clinical setting, often defined by clinical symptoms and ECG changes. In addition, the medical community now appreciates that symptoms often can be subtle or even nonexistent and that ECG changes can be totally absent (10).

With this history in mind, in July 1999, the European Society of Cardiology (ESC) and the American College of Cardiology (ACC) convened a conference to discuss refinements in the diagnosis of AMI (11,12). By this time, not only was the paradigm of requiring marker elevations for the diagnosis of AMI well entrenched clinically, but a new marker known as troponin had supplanted CK-MB as the analyte of choice for the diagnosis of myocardial injury (13–15). The ESC/ACC task force, and particularly the panel on biochemistry, considered these trends and fashioned criteria to account for improvements in these investigative tools.

## THE 1999 ESC/ACC DEFINITION

The ESC/ACC task force embraced the prevailing clinical reality and insisted that the diagnosis of myocardial infarction (MI) require biochemical evidence of cardiac injury in the appropriate clinical setting (11,12). The group also identified troponin as the preferred biomarker of myocardial injury. The formal redefinition criteria (11,12) (Table 1) included the following:

1. Typical rise and gradual fall (troponin) or more rapid rise and fall (CK-MB) of biochemical markers of myocardial necrosis with at least one of the following: ischemic symptoms; or development of pathological Q waves on the ECG; or ECG changes indicative of ischemia or coronary artery intervention;
2. Pathological findings of an acute MI.

In hindsight, two minor changes might have enhanced the definition. The first would have been to modify the required temporal change to include “a typical rise *and/or* gradual fall (troponin) or more rapid rise *and/or* fall (CK-MB)” to account for the fact that some patients who present late after the onset of infarction might manifest only

Table 1  
1999 ESC/ACC Criteria for Acute, Evolving, or Recent MI

---

Either one of the following criteria satisfies the diagnosis of acute, evolving, or recent MI:

1. Typical rise and gradual fall (troponin) or more rapid rise and fall (CK-MB) of biochemical markers of myocardial necrosis with at least one of the following:
    - Ischemic symptoms
    - Development of pathological Q waves on the ECG
    - ECG changes indicative of ischemia (ST-elevation or depression)
    - Coronary artery intervention (e.g., coronary angioplasty)
  2. Pathological findings of an AMI
- 

falling values. Another possible way to recognize this situation would be to emphasize the dynamic nature of the marker changes; that is, values that are constant and unchanging over time are rarely due to acute ischemic cardiac injury. The second potential change would be to correct the fact that the criteria failed to address the situation in which patients present with classic symptoms and ECG changes and succumb before marker values can be obtained or before elevations have time to become manifest. Under the present criteria, in the absence of an autopsy, these patients cannot be given a diagnosis of AMI. It is likely that these two problems will be remedied in subsequent iterations of the guidelines. However, the latter modification should not in any way undercut the clear intention that in almost all clinical situations the diagnosis of AMI requires elevation of a biomarker of cardiac injury.

The remainder of this chapter discusses the issues underlying the recommendations of the ESC/ACC committee, and updates the science on which the criteria are based, with particular emphasis on the issues related to the biochemistry of the cardiac biomarkers.

### TROPONIN IS THE BIOCHEMICAL MARKER OF CHOICE FOR THE DIAGNOSIS OF MYOCARDIAL INJURY

Four potential analytes were considered for inclusion in the criteria: troponin and CK-MB for primary diagnosis, and myoglobin and CK isoforms for use if early diagnosis was deemed essential. A comprehensive review of these analytes can be found in Chapter 1 (16). However, certain basic principles are worth noting.

#### *Release and Clearance Kinetics*

The characteristics of the macromolecules measured will determine their optimal use diagnostically. Markers that are relatively small, such as myoglobin (mol wt = 17,800 Daltons), are released more rapidly from myocardium and cleared more rapidly from plasma than are larger macromolecules (17,18). The advantage of these smaller markers is that because they are cleared rapidly, they are normally present only in low levels in plasma; thus, their rapid release is more easily detectable, permitting earlier diagnosis. On the other hand, because of the rapid clearance, the diagnostic window for detection of myocardial injury with small molecules, such as myoglobin, is narrow. The troponins are of intermediate molecular weight (23,500–33,500 Daltons) and are released rapidly from myocardium owing to an immediately releasable “cytosolic pool” (13,19–21).

Continuing release of structurally bound protein is slow and, thus, this marker remains elevated for many days (19–21). The MB isoenzyme of CK (CK-MB), whose molecular weight has been reported to be from 78,500 to 85,100 Daltons, is associated with early release that is roughly comparable with that of the troponins and an intermediate clearance time relative to myoglobin, which permits a diagnostic window of roughly 6–36 h, depending on the extent of myocardial damage (22,23).

### *Specificity for Cardiac Injury*

#### **CARDIAC TROPONIN**

Three isoforms of troponin I are expressed in human muscle tissues: one is specific to myocardial tissue (cardiac troponin I [cTnI]) and two other, slow skeletal (sskTnI) and fast skeletal (fskTnI) troponin I isoforms, are common in skeletal muscle. The cardiac isoform is structurally different from the skeletal muscle isoforms (24–26). It contains a 32 amino acid posttranslational tail that is absent in the skeletal troponin isoforms on the N-terminal part of the molecule. These additional sequences, as well as 42 and 45% of sequence dissimilarity with sskTnI and fskTnI, respectively, make possible the generation of monoclonal antibodies (MAbs) that are specific to cTnI and have no crossreactivity with skeletal forms (27). In addition, to date, cTnI has not been found to be expressed anywhere except in cardiac tissue (28), during either adult life or neonatal development or even in response to tissue damage. This later finding is reassuring, because proteins expressed during development are often reexpressed in damaged tissues as part of the repair process.

The presence of several troponin T genes (29) as well as alternative splicing (29,30) provides for the existence of the multiple troponin T isoforms. The primary RNA transcript for troponin T depends on the stage of ontogenesis. Human cardiac muscle contains four troponin T isoforms, three of which are expressed in the fetus; one isoform is characteristic for adult heart (31). The N-terminal-specific sequence of the cardiac isoform of troponin T (cardiac troponin T [cTnT]) (32,33), which is different from the skeletal muscle forms, also allows for the development of highly specific MAbs for the cardiac forms. In contrast to cTnI, the issue of cardiac specificity for cTnT is more complex. Early on, measurement of the cardiac isoform of TnT was confounded by a nonspecific tag antibody in the initial assays that caused some crossreactivity with a skeletal isoform (34). Once this antibody was replaced with one without crossreactivity, the frequency of elevation of troponin T in patients with skeletal muscle injury declined substantially (35). However, cardiac isoforms of cTnT are expressed in diseased skeletal muscle (36). Despite this fact, to date, studies using immunohistochemistry and/or polymerase chain reaction have confirmed that these isoforms are not detected by the antibodies used in the present assay (37–39). Thus, elevations of cTnT detected by the present iteration of the assay should have unique specificity for the heart equivalent to that of cTnI.

This near-perfect cardiac specificity is unique to the troponins.

#### **CREATINE KINASE**

There are three distinct isoenzymes of CK, and a mitochondrial form (40). The three isoenzyme forms are all dimers consisting of 39,000- to 42,500-Dalton subunits (41). CK-MB expression is not unique to the heart (42–44). Moreover, in patients with myopathies, the CK-MB content of skeletal muscle can increase markedly to up to 50% of the total amount per gram of tissue (45). Thus, elevations in CK-MB may occur as a result

of occasional analytical interferences and in patients with trauma, rhabdomyolysis, myopathies, renal failure (owing to a myopathy), or during the peripartum period (16,46,47).

### MYOGLOBIN

Myoglobin also lacks cardiac specificity. Myoglobin, an ubiquitous heme protein with a molecular weight of 17,800 Daltons, is found in both skeletal and cardiac muscle, but not in smooth muscle. It is found in almost every organ of the body (48). Thus, elevations can be caused by damage to many tissues as well as by reduced renal clearance of the analyte (49,50).

#### *Sensitivity for Detection of Cardiac Injury*

Troponin is far more sensitive for detection of cardiac damage than other markers of necrosis (13,19–21,51–54). Increased sensitivity is expected based on the fact that there is between 13- and 15-fold more troponin than CK-MB per gram of myocardium (13,19). Most of the troponin is complexed to the contractile apparatus (13,55). The amount that is in the “cytosolic pool,” which is the pool thought to be available for release acutely, is roughly the same concentration as that of CK-MB (13). Thus, the increased acute sensitivity of troponin manifested in multiple studies (51–53) suggests either that the structural pool of troponin is also released acutely or that the release ratio (the amount of protein found in the blood compared with that depleted from the heart) is higher for troponin. Preliminary data suggest that the latter is likely the case and that rather than a release ratio of 15%, as is the case for CK-MB in the absence of reperfusion (30% with reperfusion) (56), the release ratio for troponin may approach 100% (57). Finally, elevations in troponin persist in plasma for a prolonged period because the pool that is bound to the contractile apparatus is degraded and released slowly (19,58). This prolonged window allows for the increased detection of events and, thus, even greater apparent clinical sensitivity.

Myoglobin is highly sensitive because clearance keeps levels low. It also is released early after the onset of cardiac insults. However, studies touting myoglobin have often used high cutoff values for troponin, amplifying the apparent early sensitivity of the myoglobin marker (59–64). Data from several studies suggest that both CK and CK-MB isoforms detect acute infarction earlier than many other markers (8,59,65,66). Recent studies using contemporary troponin assays and the low cutoff values show no additive benefit (123).

#### *Specificity for Irreversible Injury*

The specificity of biomarkers for irreversible (vs reversible) injury has been an ongoing area of question in the field of biomarkers for many years. The problem is that proving the postulate one way or the other is difficult (67). The best experimental study evaluated increases in plasma CK. They were invariably associated with evidence of cardiac injury detected by electron microscopy (68). Given the difficulty of detecting injured cardiac myocytes even in this model, it is likely that if one used markers and/or criteria with even greater sensitivity, it would be impossible to find evidence of cardiac injury morphologically. On the other hand, it is likely that intense electron microscopic surveillance of the heart would find an occasional dead myocyte in totally normal hearts. Finally, there certainly are mechanisms by which even proteins as large as the troponins could be extruded from cells (69). Free troponin is smaller than CK-MB but much larger than myoglobin. However, troponins are often released as complexes that are similar in weight to CK-MB



(70,71). Thus, it is likely that if one of the markers can be released with reversible injury, all of them can be. If all markers are released after either reversible or irreversible injury, detecting the transition point for any given marker is unlikely to be possible.

Supporting the idea that troponin is released only with irreversible injury are studies that have failed to detect elevations in troponin in patients rendered ischemic (72). In addition, pathological studies by Ooi et al. (73) have invariably found evidence of myocyte death when elevations of troponin are present. However, troponin is released in experimental models of vital exhaustion (74) and there is rapid disappearance of minor transient elevations in some exercise studies (75–77) and, more important, in patients with pulmonary embolism. These findings have been used to suggest that there can be transient release from the “cytosolic pool” and that the absence of later release from the structurally bound pool is evidence of the absence of irreversible injury (78,79). Such speculation would fit with the known difficulty in infarcting the right ventricle, thus, the term *ischemic dysfunction*, coined by Goldstein (80). This issue is far from settled, but given the likelihood that it affects on all markers, it is probably not possible clinically nor important to make this distinction. If markers that can distinguish between the types of injury can be developed, then this issue may become important again.

Given these considerations, it is easy to see why troponin was selected as the preferred marker for the detection of cardiac injury. It is only when troponin testing is not available that the use of CK-MB is advocated as the primary marker for the diagnosis of cardiac injury. Total CK, aspartate aminotransferase, and lactate dehydrogenase no longer have a role in the diagnosis of AMI.

## DETECTION OF MYOCARDIAL DAMAGE

Once troponin was identified as the marker of choice, there were still several important considerations, which are discussed below.

### *Biochemical Criteria Used for Diagnosis of Myocardial Injury*

In 1999, the appropriate biochemical criteria for MI were far from clear. The National Academy of Clinical Biochemistry had suggested that there be two troponin cutoff values (53): one to define infarction and a second designation for unstable angina with minimal myocardial necrosis. Such an approach had been facilitated by companies that, recognizing the markedly improved sensitivity of troponin, had recommended the two-cutoff approach and had commercialized assays based on an AMI cutoff to avoid increasing the number of MIs that were being diagnosed. It was feared that to do otherwise would upset clinicians and undercut the utility of troponin testing. Such an approach had the advantage of avoiding an increasing number of small MIs with the attendant insurance, psychological, and logistic problems that can face patients postinfarction, and many physicians favored such criteria. The difficulties with such an approach were several-fold:

1. Such an approach lacked a strong scientific basis for its advocacy. In essence, it maintained the insensitive and nonspecific criteria predicated on CK-MB with all of the difficulties attendant to that approach. Furthermore, CK-MB assays were not standardized themselves, and even today there can be up to threefold differences between assays (81).
2. The problems of accepting this approach would have been compounded with the heterogeneity of troponin assays and cutoff values in use as well. There are marked differences in the sensitivity of troponin assays (82,83). Furthermore, the MI cutoff values, which

were often called receiver operating characteristic (ROC) values, were well established for some assays based on large numbers of patients, whereas for others, there were no data on which to base this decision limit.

3. The development of an additional category of patients based not on pathophysiology but on the need to preserve a prior, clearly flawed paradigm also was not attractive. What would happen when assays became more sensitive?
4. By that time, it was clear that elevated troponin was associated with increased short- and long-term risk, anatomy, and pathophysiology indistinguishable from that of conventionally diagnosed non-Q MI (84–87).

For these reasons, the concept of two cutoff values was eliminated. Instead, a normal range was defined with values above that range considered abnormal. Although this approach did not and could not eliminate the problems of assay variability totally, it at least provided consistent criteria across assays and provided a guideline that could/would remain consistent even as assays changed. Thus, the definition states that when there is evidence of cardiac injury and the mechanism of that injury appears to be myocardial ischemia, the term *myocardial infarction* is appropriate.

### *Defining Normal Range*

For most tests, the normal range includes the mean  $\pm$  2 SDs (the 95th percentile) as a way of defining the 2.5% of high values that should be considered abnormal. However, given the critical importance of this measurement to diagnosis and treatment, the 99th percentile, or roughly 3 SDs from the mean, was recommended to eliminate false-positive values. Such an approach was also favored by the ESC/ACC committee because of the potential for analytical false positives owing to the imprecision of assays at very low values (82).

Depending on the baseline one uses, the cutoff values, and assay sensitivity for CK-MB, the application of troponin rather than CK-MB results in a 30–130% increase in the frequency of MI (88–96). The relative sensitivity of troponin relative to CK-MB is illustrated by the data in Tables 2 and 3. Because patients with ST-elevation MI (STEMI) typically manifest large increases in biomarkers of necrosis, patients diagnosed solely based on troponin are almost exclusively patients with non-STEMI (89,93–95). Such patients have a low short-term mortality but a higher near-term risk of recurrent ischemic events (87). Because there is a strong relationship between the degree of elevation in troponin and risk of mortality (85,93) and patients with elevations in troponin without increases in CK-MB will be those with the least severe elevations, it is not surprising that patients with only troponin elevations appear to be at lower risk of mortality than those with elevations of both (84,85,97).

There is a need to define reference values in a more precise manner. Populations used to describe normal values are often those most conveniently available and may not contain adequate numbers of patients to assess age and gender-related, and/or racial differences. The biomarker concentrations in such populations are rarely normally distributed and correction for this problem is rarely made. Investigators have begun to address these issues, and for some assays it appears that age, gender, and/or race corrections may be needed (98–100). However, the availability of proper reference values does not eliminate the need for each laboratory to provide its own due diligence in this area, as well as appropriate quality control measures, including the ability to detect analytic problems with cross-reactivity and/or heterophilic antibodies.

Table 2  
Effect of Varying “Diagnostic” Troponin I Value on Number of Patients With MI<sup>a</sup>

	<i>cTnI</i> (+)	<i>cTnI</i> (+), <i>CK-MB</i> (-)	<i>cTnI</i> (-), <i>CK-MB</i> (+)	Relative change (%)
Lower-limit detection	483 (22)	328 (15)	4 (0.18)	+195
Optimal (<15% CV)	331 (15)	180 (8.2)	6 (0.27)	+104
Upper-limit detection	216 (9.7)	69 (3.2)	21 (0.965)	+28

<sup>a</sup>Data are reported as the number (%). *cTnI* (+): *cTnI*-positive patients for the designated cutoff value; *cTnI* (+), *CK-MB* MI (-): patients who did not meet *CK-MB* criteria for MI but had *cTnI* elevations at the designated cutoff value; *cTnI* (-), *CK-MB* MI (+): patients who met *CK-MB* criteria for MI but did not have *cTnI* elevations. The latter are almost surely false-positive *CK-MB* results. (Modified from ref. 104 with permission.)

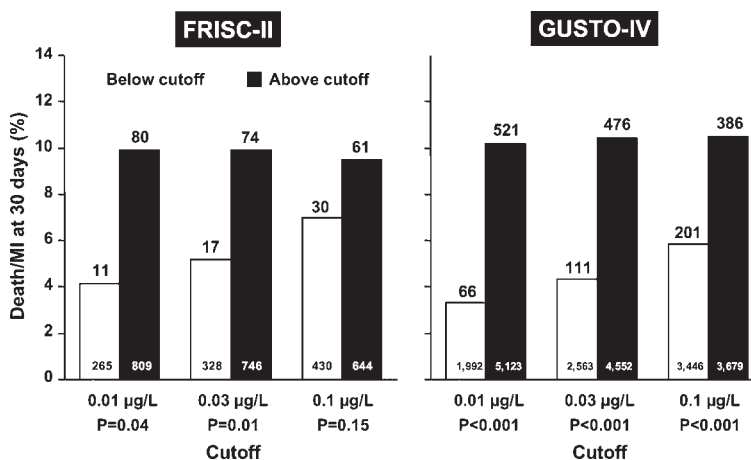
Table 3  
Change in Prevalence of Diagnosed Myocardial Infarction Using Troponin  
Cutoff Value at CV 15% With Different Criteria for Diagnosis Based on *CK-MB*

Definition of MI	Prevalence of MI (%)	<i>cTnI</i> positive (%)	Additional MIs (%)	Relative increase (%)
MB ⊕ 5 ng/mL	19.8	15.2	(-) 4.6	(-) 23
MB ⊕ 10 ng/mL	10.7	15.2	(+) 4.4	(+) 41
MB ⊕ 8 ng/mL with RI ⊕ 4	7.6	15.2	(+) 7.7	(+) 99
Inc MB, CK ⊕ 1X normal	9.0	15.2	(+) 7.6	(+) 68
Inc MB, CK ⊕ 2X normal	5.4	15.2	(+) 9.7	(+) 178
Only ischemic ECG changes				
MB ⊕ 8 ng/mL with RI ⊕ 4	21.6	35.8	(+) 14.2	(+) 66
Inc MB, CK ⊕ 1X normal	18.1	35.8	(+) 17.7	(+) 98
Inc MB, CK ⊕ 2X normal	11.7	35.8	(+) 24	(+) 206

RI, *CK-MB* ratio (calculated as *CK-MB* ↔ 100/Total *CK*). (Modified from ref. 104 with permission.)

### Issues Related to Imprecision

There was significant concern that the high imprecision at the low cutoff values suggested would result in frequent analytic false positives. Accordingly, it was recommended that the 99th percentile be measured with a coefficient of variation (CV) ≤10%. This value, which initially led to complaints from the diagnostic industry, was predicated on several factors and is really a conservative estimate. Data to define the 10% CV were available at that time only through the diagnostic companies and were usually based on within-assay variability. Such an approach underestimates assay variability significantly, because it ignores the additional variability that occurs across different runs, on different machines, on different days, and with different lots of reagents. Thus, the true variability is likely nearly double what is claimed by within-assay variability (101). If one then doubles the results from one publication that examined within-assay results at the 99th percentile, as many as 15% of samples at that concentration might yield results for which one of the values was considered elevated and the other “normal” (102). Because elevations in troponin in patients with ischemic heart disease trigger aggressive anticoagulant therapy (103–105), low-molecular-weight heparin use (106), and consideration of invasive evaluation (107–110), it is desirable to avoid analytic false positives. Thus, it was recommended that the 99th percentile value be measured with a CV ≤10%. In July 2004, the first assay to meet



**Fig. 1.** Rate of combined end point of death and MI at 30 d among patients with troponin T levels above (black bars) or below (white bars) evaluated cut points (0.01, 0.03, and 0.1 µg/L) in FRISC-II and GUSTO-IV studies. (Modified from ref. 119 with permission.)

these criteria was made available (111). Until more studies are done, diagnostic companies will continue to provide the critical information that is necessary to define assay characteristics. The ESC/ACC committee strongly urged that assay validation studies be published in the peer-reviewed literature in the hope of improving the level of sophistication and accuracy of the information. Recently, the International Federation for Clinical Chemistry (IFCC) group on markers of necrosis has codified criteria to be used for “quality troponin assays” (112).

In aggregate, this call for rigorously low imprecision has driven the assays to marked improvement. However, controversy remains regarding the value that should be used if an assay fails, as most do, to meet the criteria proposed. We and others have advocated using the value at which there is 10% imprecision to avoid analytic false positives (113). It is true that in some analyses, a small number of patients with acute coronary syndromes (ACS) who have an adverse prognosis are missed by such an approach (114) (Fig. 1).

However, it was thought that the requirement for a CV ≤10% would reduce the potential for analytic false positives with low-level elevations in patients with a lower clinical probability of ACS. In fact, as long as the normal value study is done similarly to the precision evaluations, the percentage of false positives will not be altered by using the 10% CV value. Accordingly, it is likely that the requirement for a CV <10% will not be included in updates to the ESC/ACC guidelines.

### Summary

The aforementioned criteria have worked remarkably well. Despite increases in the sensitivity of available assays, the relationship between troponin results with short- and long-term prognosis has been maintained (84–87,114). Specifically, elevations of troponin in patients who present with acute ischemic symptoms are associated with a substantially higher short- and long-term risk of death and recurrent ischemic events, and these patients benefit from aggressive antithrombotic therapies, including platelet glycoprotein IIb/IIIa antagonists (103–105), and low-molecular-weight heparin (106), as well an early invasive management strategy (107–110). It is possible that as assays for troponin

become still more sensitive, prognosis and therapeutic decision making may no longer track closely with diagnosis because event rates at very low levels may be so low that they cannot be distinguished from the event rate in troponin-negative patients. This finding would not necessarily obviate the diagnosis of acute infarction but, rather, require accurate characterization of risk by the clinician. Moreover, to date, any reliably detected concentration of troponin in patients with ACS appears to be associated with increased risk of recurrent ischemic events.

## MI IN SPECIFIC CLINICAL SETTINGS

### *Percutaneous Coronary Artery Intervention*

An increase in cardiac biomarkers after percutaneous coronary intervention is indicative of cardiac cell injury. Because this necrosis occurs as a result of myocardial ischemia, elevations in biomarkers in this setting meet the definition for the diagnosis of AMI. However, this is one setting in which diagnostic criteria for AMI and levels of troponin associated with adverse prognosis may not be homogeneous.

### *Cardiac Surgery*

Myocardial damage in association with cardiac surgery can be caused by different mechanisms, including direct trauma to the heart; focal trauma from surgical manipulation; global ischemia from inadequate perfusion, myocardial cell protection, or anoxia; coronary artery or venous graft embolism; and other complications of the procedure. Some causes of this damage may be unavoidable. Moreover, no biomarker is capable of distinguishing damage owing to an acute infarction from the usually small quantity of myocardial cell damage associated with the procedure itself. Nevertheless, the higher the concentration of the cardiac biomarker after the procedure, the greater the amount of damage to the myocardium, irrespective of the mechanism of injury (115).

### *Clinical Trials*

MI is used both as an entry criterion and as an end point in clinical trials. In general, the criteria employed for admission and for ascertainment of end point are the same. Using the criteria suggested for clinical use maximizes the ability of the trial data to be extrapolated to routine clinical care. Conversely, modification of the definition impacts patient selection and the generalizability of the trial outcomes. However, if trials elect to use high values, it is suggested that they use multiples of the suggested cutoff values as criteria to allow for easier comparability among trials (113). The appendix to this chapter provides additional recommendations.

## ADDITIONAL CONSIDERATIONS FOR CLINICAL USE

There are several other considerations for clinical use of biomarkers. First, increases in biomarkers of cardiac injury reflect myocardial damage but do not indicate its mechanism. Thus, elevated values in the absence of clinical evidence of ischemia should prompt a search for other causes of cardiac damage. Second, sampling must be done adequately in order to confirm or exclude the presence of MI. Such sampling includes a sample on admission and one at least 6–9 h thereafter, i.e., at least 6 h after the onset of symptoms. If, as is often the case, it is difficult to ascertain the onset of symptoms, timing should be

based on the time of presentation. If symptoms recur, then the clock must be “reset.” Third, early release analytes such as myoglobin and CK isoforms should only be used, unless the data will result in a change in therapy. As troponin assays improve, it is becoming less and less clear that these early analytes play any role. Previous studies suggesting they may be of benefit are often based on high troponin assay cutoff values and/or insensitive assays (59–64).

## CONCLUSION

The following biomarker criteria define cardiac injury:

1. Maximal concentration of troponin T or I exceeding the decision limit (99th percentile of the values for a reference control group) manifesting a dynamic pattern on at least one occasion during the first 24 h after the index clinical event; if the value is between the 99th percentile and the 10% CV level, caution is warranted, because analytic false-positive results can occur.
2. In the unusual situation in which troponin assays are not available, the value of CK-MB (preferably CK-MB mass) exceeding the 99th percentile of the values for a reference control group, and manifesting a dynamic pattern, can be used for diagnosis. It should be understood that CK-MB criteria will not detect substantial numbers of patients with MI.

## APPENDIX: APPLICATION OF ESC/ACC RECOMMENDATIONS TO CLINICAL TRIALS

The first attempt to operationalize the ESC/ACC guidelines and to apply them to clinical trials has been published recently and is reprinted here with permission (113). They at least begin to define some of the complicated areas where specific criteria may require interpretation.

### 1. Spontaneous myocardial infarction.

- A. When the baseline concentration is unknown and therefore assumed to be <99th percentile, as in patients who come to the hospital with acute symptoms, we propose that a rise of cardiac troponin values above the value defined by the 10% CV be considered indicative of cardiac injury. Increases should be present during the initial 24 hours of observation after AMI. If one is trying to diagnose infarction days after onset of symptoms, one may have to rely on a more gradual falling pattern of cardiac marker values. Values that remain unchanged over days are usually not the result of AMI in the absence of complications such as cardiogenic shock. As indicated in the ESC/ACC document, determination of mechanism is a clinical distinction and would be predicated on electrocardiogram, symptoms, angiography and perhaps other clinical testing. If the mechanism is ischemic, the proper term is AMI.

Such an approach will provide highly sensitive detection of cardiac injury. This is supported by evidence that increases of cardiac troponin values lower than the ROC curve cutoff values, but above the 10% CV cutoff value we now advocate, are associated with substantial increases in post-event morbidity and mortality (87, 116). It is the recommendation of the ESC/ACC that patients with such increases resulting from ischemic heart disease be diagnosed as having AMI.

- B. In some patients a baseline value may have been measured (eg, in hospitalized patients) and may be greater than the 99th percentile but less than the level with 10% imprecision. In this situation, minor increases may cause the value to exceed the 10% CV cutoff value. These individuals should be diagnosed as having AMI when the value rises above the cutoff value proposed, even if the increment of change is small.
- C. For the patient who has an elevated cardiac troponin above the cutoff value of 10% imprecision, it may be difficult to determine whether increasing values are the result of recurrent infarction or the elevations from the acute event. If the increase is >25% above the baseline value (the value when the patient arrives), it should be considered significant and indicative of recurrent or ongoing injury. For example, if the initial value is 0.08 µg/L, a rise to a value 0.1 µg/L (i.e., an increase of >0.02 µg/L or 25%) would be considered indicative of ongoing or recurrent injury. This percentage change is arbitrary but excludes changes that result from analytic or biological variability. Such criteria should be robust for most assays because at higher values there is excellent analytic precision for most assays. A distinction on the basis of the timing of increases and the clinical situation will need to be made to distinguish recurrent infarction, if AMI is days old, from changes related to the kinetics of cardiac troponin release, if AMI is acute.
- D. For clinical trials, the definitions of spontaneous AMI could use the same criteria as the clinical criteria. Such criteria would allow broad extrapolation of the results of the trial to all patients diagnosed with the ESC/ACC criteria. Alternatively, a higher value could be used in increments of two-, three-, or fourfold increases above the cutoff value to make the diagnosis. However, with this strategy, the results of the clinical trial could not be extrapolated in a direct way to all patients diagnosed with AMI, per the ESC/ACC clinical criteria. The use of multiples of the cutoff values would further exacerbate differences between assays.

## 2. Infarction after percutaneous coronary intervention (PCI).

The interpretation of biomarker increases after PCI has been controversial. In 1999, in response to a critique (117), Califf et al. (118) developed criteria that a threefold increase in biomarkers should be considered indicative of AMI. The field has progressed by use of this criterion and also by tabulation of increments on the basis of absolute, onefold, twofold, threefold, and still higher increments of increase. The data suggest that there is prognostic significance to such increments (117). The ESC/ACC guidelines do not attempt to refocus the field or to mandate specific criteria. The guidelines argue that increases of cardiac troponin are indicative of cardiac injury and, because the mechanism is ischemic with PCI associated increases, the proper term is AMI. They suggest that infarctions of this nature be dealt with separately for the purposes of clinical care, clinical trials and reimbursement (15). Accordingly, for PCI we would make the following marker recommendations.

- A. As with spontaneous AMI, if the baseline value is normal or unknown, one should use an increase above the cutoff value determined at 10% of the level of imprecision as indicative of periprocedural AMI.
- B. If the baseline value is known and is near the cutoff value, we recommend that increases that raise cardiac troponin above the cutoff with a  $\oplus$ 25% increase from baseline be considered indicative of periprocedural AMI. If the value increases by

<25% but exceeds the cutoff value, the diagnosis of AMI can still be made but we would not consider such an event a periprocedural AMI.

- C. If the value is increased before the PCI, a  $\oplus$ 25% increase with spontaneous infarctions would define recurrent injury associated with PCI.
- D. For clinical trials implementation, we again suggest centralized documentation of laboratory information regarding the assay name and instrumentation used and the collection of the raw values so that one can apply consistent standards. The criteria suggested for clinical use should be the same as those used for clinical trials. Increases could be tabulated in terms of increments from the upper cutoff value of one-, two-, three-, or fourfold because there appears to be some utility to such an approach (117). Such values are not a good surrogate for infarct size. If clinical trials wish to use higher standards (two- or threefold increases), or other suggested solutions, they should recognize that this reduces the ability to extrapolate their results to the overall realm of patients with PCI-related AMI. The use of multiples of the cutoff values would further exacerbate differences between assays. Finally, as suggested by the ESC/ACC guidelines, infarctions related to interventions should be reported separately from spontaneous events (15).

### 3. Infarction after coronary artery bypass surgery (CABG).

The situation for patients undergoing CABG is too complex to define simple cutoff values. There are differences in the amount of protein released that depend on the operation, the surgical approach, and the cardioplegia. The release of biomarkers can be the result of graft closure and myocardial infarction or a variety of other situations related to cardioplegia and operative techniques during which there is an obligatory amount of cardiac injury not resulting from infarction (118). We do not know how to separate these components. This augments the variability related to the assays. A clinical approach predicated on local results to define the cutoff values that might be used to define patients at risk for complications for each type of operation (aortic valve alone, mitral valve alone, CABG alone, and combined procedures) could be developed as follows.

- A. This reference value for normal procedures would be determined by use of local anesthetic and operative surgical techniques with the assay proposed for use.
- B. This reference value would vary if the assay were different in different institutions, even if the techniques were the same.
- C. This reference value would vary with the same assay if the techniques varied between institutions. For example, warm cardioplegia releases an increased amount of marker compared with cold cardioplegia (119).

On the basis of local experience with anesthetic and surgical techniques and the above mentioned biomarker definition, one could define the expected peak value after each type of surgical procedure. Marked increases (5- to 10-fold) above this value could then be applied centrally to define adverse events for clinical trials. This criterion would have to be determined for each assay and for each institution. Even so, the designation of an adverse event or complication would not necessarily reflect the presence of infarction but the conjoint amount of injury from all causes. The more marked the increase, the greater the likelihood of adverse clinical consequences (120). If such an approach is used, multiple samples—including samples at 24 and 36 h after surgery—to locate a peak value are essential (121,122).



## REFERENCES

1. Tunstall-Pedoe H, Kuulasmaa K, Amouyel P, Arveiler D, Rajakangas AM, Pajak A. Myocardial infarction and coronary deaths in the World Health Organization MONICA Project: registration procedures, event rates, and case-fatality rates in 38 populations from 21 countries in four continents. *Circulation* 1994; pp. 583–612.
2. WHO Expert Committee on Cardiovascular Disease and Hypertension. Hypertension and coronary heart disease: classification and criteria for epidemiological studies. *World Health Organization Tech Support Ser* 1959;168:3–28.
3. Karmen A, Wroblewski F, Ladue JS. Transaminase activity in human blood. *J Clin Invest* 1955; pp. 126–131.
4. Anonymous. The pathological diagnosis of acute myocardial infarction: preliminary results of a WHO cooperative study. *Bull World Health Org* 1973; pp. 23–25.
5. Shell WE, Kjekshus JK, Sobel BE, eds. Quantitative assessment of the extent of myocardial infarction in the conscious dog by means of analysis of serial changes in serum creatine phosphokinase activity. *J Clin Invest* 1971;50:2614–2625.
6. Roberts R, Henry PD, Witteveen SA, Sobel BE. Quantification of serum creatine phosphokinase isoenzyme activity. *Am J Cardiol* 1974; pp. 650–654.
7. Roberts R, Gowda KS, Ludbrook PA, Sobel BE. Specificity of elevated serum MB creatine phosphokinase activity in the diagnosis of acute myocardial infarction. *Am J Cardiol* 1975; pp. 433–437.
8. Jaffe AS, Serota H, Grace A, Sobel BE. Diagnostic changes in plasma creatine kinase isoforms early after the onset of acute myocardial infarction. *Circulation* 1986; pp. 105–109.
9. Abendschein D, Seacord LM, Nohara R, Sobel BE, Jaffe AS. Prompt detection of myocardial injury by assay of creatine kinase isoforms in initial plasma samples. *Clin Cardiol* 1988; pp. 661–664.
10. Lee TH, Rouan GW, Weisberg MC, et al. Sensitivity of routine clinical criteria for diagnosing myocardial infarction within 24 hours of hospitalization. *Ann Intern Med* 1987; pp. 181–186.
11. Myocardial infarction redefined—a consensus document of The Joint European Society of Cardiology/American College of Cardiology Committee for the redefinition of myocardial infarction. *Eur Heart J* 2000; pp. 1502–1513.
12. Alpert JS, Thygesen K, Antman E, Bassand JP. Myocardial infarction redefined—a consensus document of The Joint European Society of Cardiology/American College of Cardiology Committee for the redefinition of myocardial infarction. *J Am Coll Cardiol* 2000; pp. 959–969.
13. Adams JE 3rd, Schechtman KB, Landt Y, Ladenson JH, Jaffe AS. Comparable detection of acute myocardial infarction by creatine kinase MB isoenzyme and cardiac troponin I. *Clin Chem* 1994; pp. 1291–1295.
14. Wu AH, Lane PL. Metaanalysis in clinical chemistry: validation of cardiac troponin T as a marker for ischemic heart diseases. *Clin Chem* 1995; pp. 1228–1233.
15. Jaffe AS, Ravkilde J, Roberts R, et al. It's time for a change to a troponin standard. *Circulation* 2000; pp. 1216–1220.
16. Adams JE 3rd, Abendschein DR, Jaffe AS. Biochemical markers of myocardial injury: is MB creatine kinase the choice for the 1990s? *Circulation* 1993; pp. 750–763.
17. Grenadier E, Keidar S, Kahana L, Alpan G, Marmur A, Palant A. The roles of serum myoglobin, total CPK, and CK-MB isoenzyme in the acute phase of myocardial infarction. *Am Heart J* 1983; pp. 408–416.
18. Klocke FJ, Copley DP, Krawczyk JA, Reichlin M. Rapid renal clearance of immunoreactive canine plasma myoglobin. *Circulation* 1982; pp. 1522–1528.
19. Katus HA, Remppis A, Scheffold T, Diederich KW, Kuebler W. Intracellular compartmentation of cardiac troponin T and its release kinetics in patients with reperfused and nonreperfused myocardial infarction. *Am J Cardiol* 1991; pp. 1360–1367.
20. Bleier J, Vorderwinkler KP, Falkensammer J, et al. Different intracellular compartmentations of cardiac troponins and myosin heavy chains: a causal connection to their different early release after myocardial damage. *Clin Chem* 1998; pp. 1912–1918.
21. Bertinchant JP, Larue C, Pernel I, et al. Release kinetics of serum cardiac troponin I in ischemic myocardial injury. *Clin Biochem* 1996; pp. 587–594.
22. Sobel BE, Shell WE. Serum enzyme determinations in the diagnosis and assessment of myocardial infarction. *Circulation* 1972; pp. 471–482.
23. Cox DA, Stone PH, Muller JE, et al. Prognostic implications of an early peak in plasma MB creatine kinase in patients with acute myocardial infarction. *J Am Coll Cardiol* 1987; pp. 979–990.

24. Vallins WJ, Brand NJ, Dabhade N, Butler-Browne G, Yacoub MH, Barton PJ. Molecular cloning of human cardiac troponin I using polymerase chain reaction. *FEBS Lett* 1990; pp. 57–61.
25. Wade R, Eddy R, Shows TB, Kedes L. cDNA sequence, tissue-specific expression, and chromosomal mapping of the human slow-twitch skeletal muscle isoform of troponin I. *Genomics* 1990; pp. 346–357.
26. Zhu L, Perez-Alvarado G, Wade R. Sequencing of a cDNA encoding the human fast-twitch skeletal muscle isoform of troponin I. *Biochim Biophys Acta* 1994; pp. 338–340.
27. Katrukha A. Antibody selection strategies in cardiac troponin assay. In: Wu AHB, ed. *Cardiac Markers*, 2nd ed. Humana Press, Totowa, NJ, 2003; pp. 173–185.
28. Toyota N, Shimada Y. Differentiation of troponin in cardiac and skeletal muscles in chicken embryos as studied by immunofluorescence microscopy. *J Cell Biol* 1981; pp. 497–504.
29. Perry SV. Troponin T: genetics, properties and function. *J Muscle Res Cell Motil* 1998; pp. 575–602.
30. Anderson PA, Greig A, Mark TM, et al. Molecular basis of human cardiac troponin T isoforms expressed in the developing, adult, and failing heart. *Circ Res* 1995; pp. 681–686.
31. Filatov VL, Katrukha AG, Bulargina TV, Gusev NB. Troponin: structure, properties, and mechanism of functioning. *Biochemistry (Mosc)* 1999; pp. 969–985.
32. Gahlmann R, Troutt AB, Wade RP, Gunning P, Kedes L. Alternative splicing generates variants in important functional domains of human slow skeletal troponin T. *J Biol Chem* 1987; pp. 16,122–16,126.
33. Mesnard L, Logeart D, Taviaux S, Diriong S, Mercadier JJ, Samson F. Human cardiac troponin T: cloning and expression of new isoforms in the normal and failing heart. *Circ Res* 1995; pp. 687–692.
34. Katus HA, Looser S, Hallermayer K, et al. Development and in vitro characterization of a new immunoassay of cardiac troponin T. *Clin Chem* 1992; pp. 386–393.
35. Muller-Bardorff M, Hallermayer K, Schroder A, et al. Improved troponin T ELISA specific for cardiac troponin T isoform: assay development and analytical and clinical validation. *Clin Chem* 1997; pp. 458–466.
36. Bodor GS, Survant L, Voss EM, Smith S, Porterfield D, Apple FS. Cardiac troponin T composition in normal and regenerating human skeletal muscle. *Clin Chem* 1997; pp. 476–484.
37. Haller C, Zehelein J, Remppis A, Muller-Bardorff M, Katus HA. Cardiac troponin T in patients with end-stage renal disease: absence of expression in truncal skeletal muscle. *Clin Chem* 1998; pp. 930–938.
38. Ricchiuti V, Voss EM, Ney A, Odland M, Anderson PA, Apple FS. Cardiac troponin T isoforms expressed in renal diseased skeletal muscle will not cause false-positive results by the second generation cardiac troponin T assay by Boehringer Mannheim. *Clin Chem* 1998; pp. 1919–1924.
39. Ricchiuti V, Apple FS. RNA expression of cardiac troponin T isoforms in diseased human skeletal muscle. *Clin Chem* 1999; pp. 2129–2135.
40. Jacobs H, Heldt HW, Klingenberg M. High activity of creatine kinase in mitochondria from muscle and brain and evidence for a separate mitochondrial isoenzyme of creatine kinase. *Biochem Biophys Res Commun* 1964; pp. 516–521.
41. Dawson DM, Eppenberger HM, Kaplan NO. Creatine kinase: evidence for a dimeric structure. *Biochem Biophys Res Commun* 1965; pp. 346–353.
42. Tsung JS, Tsung SS. Creatine kinase isoenzymes in extracts of various human skeletal muscles. *Clin Chem* 1986; pp. 1568–1570.
43. Wilhelm AH, Alberts KM, Todd JK. Creatine phosphokinase isoenzyme distribution in human skeletal and heart muscles. *IRCS Med Sci* 1976; pp. 418–420.
44. Mair J. Cardiac troponin I and troponin T: are enzymes still relevant as cardiac markers? *Clin Chim Acta* 1997; pp. 99–115.
45. Larca LJ, Coppola JT, Honig S. Creatine kinase MB isoenzyme in dermatomyositis: a noncardiac source. *Ann Intern Med* 1981; pp. 341–343.
46. Lee TH, Goldman L. Serum enzyme assays in the diagnosis of acute myocardial infarction: recommendations based on a quantitative analysis. *Ann Intern Med* 1986; pp. 221–233.
47. Mair J, Puschendorf B, Michel G. Clinical significance of cardiac contractile proteins for the diagnosis of myocardial injury. *Adv Clin Chem* 1994; pp. 63–98.
48. Kagen LJ. *Myoglobin: Biochemical, Physiological and Clinical Aspects*. Columbia University Press, New York, 1973.
49. Roberts R. Myoglobinemia as index to myocardial infarction. *Ann Intern Med* 1977; pp. 788, 789.
50. Groth T, Hakman M, Sylven C. Prediction of myocardial infarct size from early serum myoglobin observations. *Scand J Clin Lab Invest* 1987; pp. 599–603.
51. Gerhardt W, Nordin G, Ljungdahl L. Can troponin T replace CK MBmass as “gold standard” for acute myocardial infarction (“AMI”)? *Scand J Clin Lab Invest Suppl* 1999; pp. 83–89.

52. Katus HA, Remppis A, Neumann FJ, et al. Diagnostic efficiency of troponin T measurements in acute myocardial infarction. *Circulation* 1991; pp. 902–912.
53. Wu AH, Apple FS, Gibler WB, Jesse RL, Warshaw MM, Valdes R Jr. National Academy of Clinical Biochemistry Standards of Laboratory Practice: recommendations for the use of cardiac markers in coronary artery diseases. *Clin Chem* 1999; pp. 1104–1121.
54. Apple FS, Falahati A, Paulsen PR, Miller EA, Sharkey SW. Improved detection of minor ischemic myocardial injury with measurement of serum cardiac troponin I. *Clin Chem* 1997; pp. 2047–2051.
55. Voss EM, Sharkey SW, Gernert AE, et al. Human and canine cardiac troponin T and creatine kinase-MB distribution in normal and diseased myocardium: infarct sizing using serum profiles. *Arch Pathol Lab Med* 1995; pp. 799–806.
56. Vatner SF, Baig H, Manders WT, Maroko PR. Effects of coronary artery reperfusion on myocardial infarct size calculated from creatine kinase. *J Clin Invest* 1978; pp. 1048–1056.
57. Tanaka H, Abe S, Yamashita T, et al. Serum levels of cardiac troponin I and troponin T in estimating myocardial infarct size soon after reperfusion. *Coron Artery Dis* 1997; pp. 433–439.
58. Jaffe AS, Landt Y, Parvin CA, Abendschein DR, Geltman EM, Ladenson JH. Comparative sensitivity of cardiac troponin I and lactate dehydrogenase isoenzymes for diagnosing acute myocardial infarction. *Clin Chem* 1996; pp. 1770–1776.
59. Zimmerman J, Fromm R, Meyer D, et al. Diagnostic marker cooperative study for the diagnosis of myocardial infarction. *Circulation* 1999; pp. 1671–1677.
60. McCord J, Nowak RM, McCullough PA, et al. Ninety-minute exclusion of acute myocardial infarction by use of quantitative point-of-care testing of myoglobin and troponin I. *Circulation* 2001; pp. 1483–1488.
61. Apple FS, Christenson RH, Valdes R Jr, et al. Simultaneous rapid measurement of whole blood myoglobin, creatine kinase MB, and cardiac troponin I by the triage cardiac panel for detection of myocardial infarction. *Clin Chem* 1999; pp. 199–205.
62. Apple FS, Anderson FP, Collinson P, et al. Clinical evaluation of the first medical whole blood, point-of-care testing device for detection of myocardial infarction. *Clin Chem* 2000; pp. 1604–1609.
63. Penttila K, Koukkunen H, Halinen M, et al. Myoglobin, creatine kinase MB isoforms and creatine kinase MB mass in early diagnosis of myocardial infarction in patients with acute chest pain. *Clin Biochem* 2002; pp. 647–653.
64. Newby LK, Storrow AB, Gibler WB, et al. Bedside multimarker testing for risk stratification in chest pain units: the chest pain evaluation by creatine kinase-MB, myoglobin, and troponin I (CHECKMATE) study. *Circulation* 2001; pp. 1832–1837.
65. Abendschein DR, Serota H, Plummer TH Jr, et al. Conversion of MM creatine kinase isoforms in human plasma by carboxypeptidase N. *J Lab Clin Med* 1987; pp. 798–806.
66. Puleo PR, Meyer D, Wathen C, et al. Use of a rapid assay of subforms of creatine kinase-MB to diagnose or rule out acute myocardial infarction. *N Engl J Med* 1994; pp. 561–566.
67. Wu AH, Ford L. Release of cardiac troponin in acute coronary syndromes: ischemia or necrosis? *Clin Chim Acta* 1999; pp. 161–174.
68. Ishikawa Y, Saffitz JE, Mealman TL, Grace AM, Roberts R. Reversible myocardial ischemic injury is not associated with increased creatine kinase activity in plasma. *Clin Chem* 1997; pp. 467–475.
69. Sobel BE, LeWinter MM. Ingenuous interpretation of elevated blood levels of macromolecular markers of myocardial injury: a recipe for confusion. *J Am Coll Cardiol* 2000; pp. 1355–1358.
70. Wu AH, Feng YJ, Moore R, et al. Characterization of cardiac troponin subunit release into serum after acute myocardial infarction and comparison of assays for troponin T and I. American Association for Clinical Chemistry Subcommittee on cTnI Standardization. *Clin Chem* 1998; pp. 1198–1208.
71. Katrukha AG, Bereznikova AV, Esakova TV, et al. Troponin I is released in bloodstream of patients with acute myocardial infarction not in free form but as complex. *Clin Chem* 1997; pp. 1379–1385.
72. Carlson RJ, Navone A, McConnell JP, et al. Effect of myocardial ischemia on cardiac troponin I and T. *Am J Cardiol* 2002; pp. 224–226.
73. Ooi DS, Isotalo PA, Veinot JP. Correlation of antemortem serum creatine kinase, creatine kinase-MB, troponin I, and troponin T with cardiac pathology. *Clin Chem* 2000; pp. 338–344.
74. Chen Y, Serfass RC, Mackey-Bojack SM, Kelly KL, Titus JL, Apple FS. Cardiac troponin T alterations in myocardium and serum of rats after stressful, prolonged intense exercise. *J Appl Physiol* 2000; pp. 1749–1755.
75. Neumayr G, Gaenzler H, Pfister R, et al. Plasma levels of cardiac troponin I after prolonged strenuous endurance exercise. *Am J Cardiol* 2001; pp. 369–371, A10.

76. Rifai N, Douglas PS, O'Toole M, Rimm E, Ginsburg GS. Cardiac troponin T and I, echocardiographic [correction of electrocardiographic] wall motion analyses, and ejection fractions in athletes participating in the Hawaii Ironman Triathlon. *Am J Cardiol* 1999; pp. 1085–1089.
77. Shave RE, Dawson E, Whyte G, George K, Gaze D, Collinson P. Effect of prolonged exercise in a hypoxic environment on cardiac function and cardiac troponin T. *Br J Sports Med* 2004; pp. 86–88.
78. Muller-Bardorff M, Weidtmann B, Giannitsis E, Kurowski V, Katus HA. Release kinetics of cardiac troponin T in survivors of confirmed severe pulmonary embolism. *Clin Chem* 2002; pp. 673–675.
79. La Vecchia L, Ottani F, Favero L, et al. Increased cardiac troponin I on admission predicts in-hospital mortality in acute pulmonary embolism. *Heart* 2004; pp. 633–637.
80. Goldstein JA. Right heart ischemia: pathophysiology, natural history, and clinical management. *Prog Cardiovasc Dis* 1998; pp. 325–341.
81. Apple FS, Murakami M, Panteghini M, et al. International survey on the use of cardiac markers. *Clin Chem* 2001; pp. 587, 588.
82. Panteghini M, Pagani F, Yeo KT, et al. Evaluation of imprecision for cardiac troponin assays at low-range concentrations. *Clin Chem* 2004; pp. 327–332.
83. James SK, Lindahl B, Armstrong P, et al. A rapid troponin I assay is not optimal for determination of troponin status and prediction of subsequent cardiac events at suspicion of unstable coronary syndromes. *Int J Cardiol* 2004; pp. 113–120.
84. Lindahl B, Venge P, Wallentin L. Relation between troponin T and the risk of subsequent cardiac events in unstable coronary artery disease. The FRISC study group. *Circulation* 1996; pp. 1651–1657.
85. Antman EM, Tanasijevic MJ, Thompson B, et al. Cardiac-specific troponin I levels to predict the risk of mortality in patients with acute coronary syndromes. *N Engl J Med* 1996; pp. 1342–1349.
86. Luscher MS, Thygesen K, Ravkilde J, Heickendorff L. Applicability of cardiac troponin T and I for early risk stratification in unstable coronary artery disease. TRIM Study Group. *Thrombin Inhibition in Myocardial Ischemia. Circulation* 1997; pp. 2578–2585.
87. Ottani F, Galvani M, Nicolini FA, et al. Elevated cardiac troponin levels predict the risk of adverse outcome in patients with acute coronary syndromes. *Am Heart J* 2000; pp. 917–927.
88. Luepker RV, Apple FS, Christenson RH, et al. Case definitions for acute coronary heart disease in epidemiology and clinical research studies: a statement from the AHA Council on Epidemiology and Prevention; AHA Statistics Committee; World Heart Federation Council on Epidemiology and Prevention; the European Society of Cardiology Working Group on Epidemiology and Prevention; Centers for Disease Control and Prevention; and the National Heart, Lung, and Blood Institute. *Circulation* 2003; pp. 2543–2549.
89. Ferguson JL, Beckett GJ, Stoddart M, Walker SW, Fox KA. Myocardial infarction redefined: the new ACC/ESC definition, based on cardiac troponin, increases the apparent incidence of infarction. *Heart* 2002; pp. 343–347.
90. Lin JC, Apple FS, Murakami MM, Luepker RV. Rates of positive cardiac troponin I and creatine kinase MB mass among patients hospitalized for suspected acute coronary syndromes. *Clin Chem* 2004; pp. 333–338.
91. Apple FS, Johari V, Hoybook KJ, Weber-Shrikant E, Davis GK, Murakami MM. Operationalizing cardiac troponin I testing along ESC/ACC consensus guidelines for defining myocardial infarction: increasing rate of detection. *Clin Chim Acta* 2003; pp. 165, 166.
92. Green GB, Beaudreau RW, Chan DW, DeLong D, Kelley CA, Kelen GD. Use of troponin T and creatine kinase-MB subunit levels for risk stratification of emergency department patients with possible myocardial ischemia. *Ann Emerg Med* 1998; pp. 19–29.
93. Ohman EM, Armstrong PW, Christenson RH, et al. Cardiac troponin T levels for risk stratification in acute myocardial ischemia. GUSTO IIA Investigators. *N Engl J Med* 1996; pp. 1333–1341.
94. Koukkunen H, Penttila K, Kempainen A, et al. Differences in the diagnosis of myocardial infarction by troponin T compared with clinical and epidemiologic criteria. *Am J Cardiol* 2001; pp. 727–731.
95. Meier MA, Al-Badr WH, Cooper JV, et al. The new definition of myocardial infarction: diagnostic and prognostic implications in patients with acute coronary syndromes. *Arch Intern Med* 2002; pp. 1585–1589.
96. Kontos MC, Fritz LM, Anderson FP, Tatum JL, Ornato JP, Jesse RL. Impact of the troponin standard on the prevalence of acute myocardial infarction. *Am Heart J* 2003; pp. 446–452.
97. Stubbs P, Collinson P, Moseley D, Greenwood T, Noble M. Prognostic significance of admission troponin T concentrations in patients with myocardial infarction. *Circulation* 1996; pp. 1291–1297.

98. Wiviott SD, Cannon CP, Morrow DA, et al. Differential expression of cardiac biomarkers by gender in patients with unstable angina/non-ST-elevation myocardial infarction: a TACTICS-TIMI 18 (Treat Angina with Aggrastat and Determine Cost of Therapy with an Invasive or Conservative Strategy-Thrombolysis In Myocardial Infarction 18) substudy. *Circulation* 2004; pp. 580–586.
99. Apple FS, Murakami MM. Serum 99th percentile reference cutoffs for seven cardiac troponin assays. *Clin Chem* 2004; pp. 1477–1479.
100. Venge P, Johnston N, Lagerqvist B, Wallentin L, Lindahl B. Clinical and analytical performance of the liaison cardiac troponin I assay in unstable coronary artery disease, and the impact of age on the definition of reference limits. A FRISC-II substudy. *Clin Chem* 2003; pp. 880–886.
101. Uettwiller-Geiger D, Wu AH, Apple FS, et al. Multicenter evaluation of an automated assay for troponin I. *Clin Chem* 2002; pp. 869–876.
102. Sheehan P, Blennerhassett J, Vasikaran SD. Decision limit for troponin I and assay performance. *Ann Clin Biochem* 2002; pp. 231–236.
103. Heeschen C, Hamm CW, Goldmann B, Deu A, Langenbrink L, White HD. Troponin concentrations for stratification of patients with acute coronary syndromes in relation to therapeutic efficacy of tirofiban. PRISM Study Investigators. Platelet Receptor Inhibition in Ischemic Syndrome Management. *Lancet* 1999; pp. 1757–1762.
104. Januzzi JL, Hahn SS, Chae CU, et al. Effects of tirofiban plus heparin versus heparin alone on troponin I levels in patients with acute coronary syndromes. *Am J Cardiol* 2000; pp. 713–717.
105. Leoncini M, Bellandi F, Sciagra R, et al. Gated SPECT evaluation of the relationship between admission troponin I, myocardial salvage, and functional recovery in acute myocardial infarction treated by abciximab and early primary angioplasty. *J Nucl Med* 2004; pp. 739–744.
106. Morrow DA, Antman EM, Tanasijevic M, et al. Cardiac troponin I for stratification of early outcomes and the efficacy of enoxaparin in unstable angina: a TIMI-11B substudy. *J Am Coll Cardiol* 2000; pp. 1812–1817.
107. Invasive compared with non-invasive treatment in unstable coronary-artery disease: FRISC II prospective randomised multicentre study. FRagmin and Fast Revascularisation during InStability in Coronary artery disease Investigators. *Lancet* 1999; pp. 708–715.
108. Cannon CP, Weintraub WS, Demopoulos LA, et al. Comparison of early invasive and conservative strategies in patients with unstable coronary syndromes treated with the glycoprotein IIb/IIIa inhibitor tirofiban. *N Engl J Med* 2001; pp. 1879–1887.
109. Neumann FJ, Kastrati A, Pogatsa-Murray G, et al. Evaluation of prolonged antithrombotic pretreatment (“cooling-off” strategy) before intervention in patients with unstable coronary syndromes: a randomized controlled trial. *JAMA* 2003; pp. 1593–1599.
110. Morrow DA, Cannon CP, Rifai N, et al. Ability of minor elevations of troponins I and T to predict benefit from an early invasive strategy in patients with unstable angina and non-ST elevation myocardial infarction: results from a randomized trial. *JAMA* 2001; pp. 2405–2412.
111. Christenson RH, Cervelli DR, Bauer RS, Gordon M. Stratus CS cardiac troponin I method: performance characteristics including imprecision at low concentrations. *Clin Biochem* 2004;37:679–683.
112. Panteghini M, Apple FS, Christenson RH, Dati F, Mair J, Wu AH. Proposals from IFCC Committee on Standardization of Markers of Cardiac Damage (C-SMCD): recommendations on use of biochemical markers of cardiac damage in acute coronary syndromes. *Scand J Clin Lab Invest Suppl* 1999; pp. 103–112.
113. Apple FS, Wu AH, Jaffe AS. European Society of Cardiology and American College of Cardiology guidelines for redefinition of myocardial infarction: how to use existing assays clinically and for clinical trials. *Am Heart J* 2002; pp. 981–986.
114. James S, Armstrong P, Califf R, et al. Troponin T levels and risk of 30-day outcomes in patients with the acute coronary syndrome: prospective verification in the GUSTO-IV trial. *Am J Med* 2003; pp. 178–184.
115. Lehrke S, Steen H, Sievers HH, et al. Cardiac troponin T for prediction of short- and long-term morbidity and mortality after elective open heart surgery. *Clin Chem* 2004;50:1560–1567.
116. Lindahl B, Diderholm E, Lagerqvist B, Venge P, Wallentin L. Mechanisms behind the prognostic value of troponin T in unstable coronary artery disease: a FRISC II substudy. *J Am Coll Cardiol* 2001; pp. 979–986.
117. Chaitman BR, Jaffe AS. What is the true periprocedure myocardial infarction rate? Does anyone know for sure? The need for clarification. *Circulation* 1995; pp. 1609, 1610.
118. Califf RM, Abdelmeguid AE, Kuntz RE, et al. Myonecrosis after revascularization procedures. *J Am Coll Cardiol* 1998; pp. 241–351.

119. Pelletier LC, Carrier M, Leclerc Y, Cartier R, Wesolowska E, Solymoss BC. Intermittent antegrade warm versus cold blood cardioplegia: a prospective, randomized study. *Ann Thorac Surg* 1994; pp. 41–48; discussion 48, 49.
120. Katus HA, Schoepenthou M, Tanzeem A, et al. Non-invasive assessment of perioperative myocardial cell damage by circulating cardiac troponin T. *Br Heart J* 1991; pp. 259–264.
121. Sadony V, Korber M, Albes G, et al. Cardiac troponin I plasma levels for diagnosis and quantitation of perioperative myocardial damage in patients undergoing coronary artery bypass surgery. *Eur J Cardiothorac Surg* 1998; pp. 57–65.
122. Alyanakian MA, Dehoux M, Chatel D, et al. Cardiac troponin I in diagnosis of perioperative myocardial infarction after cardiac surgery. *J Cardiothorac Vasc Anesth* 1998; pp. 288–294.
123. Eggers KM, Oldgren J, Nordenskjold A, Lindahl B. Diagnostic value of serial measurement of cardiac markers in patients with chest pain: limited value of adding myoglobin to troponin I for exclusion of myocardial infarction. *Am Heart J* 2004;148:574–581.



# 4

---

## Biomarkers in the Emergency Department *Rapid Diagnosis and Triage*

---

*Jin H. Han, MD and W. Brian Gibler, MD*

### CONTENTS

INTRODUCTION

EVALUATION OF CHEST PAIN IN THE ED

NOVEL MARKERS OF ISCHEMIA: POTENTIAL ROLE IN THE ED

ROLE OF CARDIAC BIOMARKERS IN CHEST PAIN PROTOCOLS

CONCLUSION

REFERENCES

---

### INTRODUCTION

Acute coronary syndrome (ACS) is a clinical syndrome ranging in severity from unstable angina to ST-elevation acute myocardial infarction (AMI). Early diagnosis and risk stratification are needed so that early treatment can appropriately be administered to those at highest risk (1). Because ACS is a heterogeneous disease process, accomplishing these goals, especially in the patient without ST-elevation, can be challenging. The emergency department (ED) is often on the front line of this challenge and is faced with 5 million patient visits for chest pain each year (2). Of these patients, approx 25% will be diagnosed with ACS (3).

In the ED setting, cardiac biomarkers have become increasingly important for the diagnosis of AMI, especially when ST-elevations are absent on a 12-lead electrocardiogram (ECG). In addition to their diagnostic utility, the ability of cardiac biomarkers to facilitate risk assessment in chest pain patients has allowed emergency physicians and cardiologists to rapidly identify and treat higher-risk patients with suspected ACS. The development of point-of-care (POC) assays has also improved time to diagnosis and treatment (4). Diagnostic algorithms, chest pain units, and rapid evaluation protocols incorporating cardiac biomarkers have been created, improving diagnostic accuracy for AMI and unstable angina while reducing hospital admissions and costs (5).

This chapter will discuss the role of cardiac biomarkers in the ED setting, and their specific applications in diagnostic algorithms, chest pain units, and rapid evaluation protocols. In order to judge the effect that these protocols and algorithms have on clinical decision making, likelihood ratios (LRs) will be reported (Table 1).

From: *Contemporary Cardiology:  
Cardiovascular Biomarkers: Pathophysiology and Disease Management*  
Edited by: David A. Morrow © Humana Press Inc., Totowa, NJ



Table 1  
LRs and Their Effect on Clinical Decision Making

+LR	-LR	Impact on clinical decision making
>10	<0.1	Strong
5–10	0.1–0.2	Moderate
2–5	0.2–0.5	Small
1	1	No change

+LR, positive likelihood ratio; -LR, negative likelihood ratio. An LR combines sensitivity and specificity of a particular test and adjusts the clinician's pretest probability of disease based on the results of a test. +LR indicates the degree that a positive test will increase the probability of disease and -LR indicates the degree that a negative test will decrease the probability of disease.

## EVALUATION OF CHEST PAIN IN THE ED

### *The Initial Assessment*

The initial evaluation of chest pain in the ED typically occurs 10 min after patient arrival and remains dependent on the initial 12-lead ECG, history, and physical examination. The presence of ST-segment deviation on the 12-lead ECG portends high risk for adverse outcomes, and patients with this finding should be treated aggressively (6). The 12-lead ECG can be initially nondiagnostic, however, in up to 50% of patients presenting to the ED (7). Moreover, the history and physical examination cannot reliably exclude the diagnosis of an AMI (8). Thus, additional testing is often necessary in order to improve diagnostic and prognostic accuracy.

Early in the course of evaluation in the ED, initial cardiac biomarkers of necrosis are obtained. Myoglobin, cardiac troponin T or cardiac troponin I (cTnI), and creatine kinase-MB (CK-MB) are commonly used to detect myocardial necrosis. However, the sensitivities of these cardiac biomarkers obtained on initial presentation may be poor and are dependent on the time from the onset of symptoms to presentation, the duration of ischemia, and the amount of myocardial tissue involved. Serial testing of cardiac biomarkers in the ED has substantially improved the detection of myocardial necrosis in this setting (9).

### *Traditional Cardiac Biomarkers Used in the ED*

#### **CK-MB ISOENZYME**

CK-MB is predominantly found in the myocardium and is the most specific of the three CK isoenzymes for the detection of myocardial necrosis. Elevation of CK-MB occurs 4–6 h after the onset of myocardial necrosis and can remain for 24–48 h (10). The initial sensitivity of CK-MB for the detection of AMI has been reported to be 23–57% (11,12). Obtaining additional CK-MB measurements incrementally improves the sensitivity; repeat testing at 3 h after initial presentation improves the sensitivity to 88% (12), and sensitivity is maximized when CK-MB sampling is performed over a 9-h evaluation period (13).

CK-MB has excellent specificity, reported to be 97–99% (11,12). However, because up to 3% of the total CK in skeletal muscle is CK-MB, nonspecific elevations can occur

in the setting of skeletal muscle damage (14). This limitation can be mitigated by calculating the CK-MB relative index, which is the proportion of CK-MB to total CK (15). A CK-MB relative index <2.5% indicates a skeletal muscle source for this enzyme.

### CARDIAC TROPONIN

With the development of assays for cardiac troponin, the definition of AMI has undergone a substantive transformation (*see* Chapter 3) (16). Similarly to CK-MB, troponin I and troponin T are detectable in the blood 4–12 h after the onset of myocardial necrosis and peak at 24–48 h. In contrast to CK-MB, elevated concentrations of cardiac troponin can persist for up to 7–10 d.

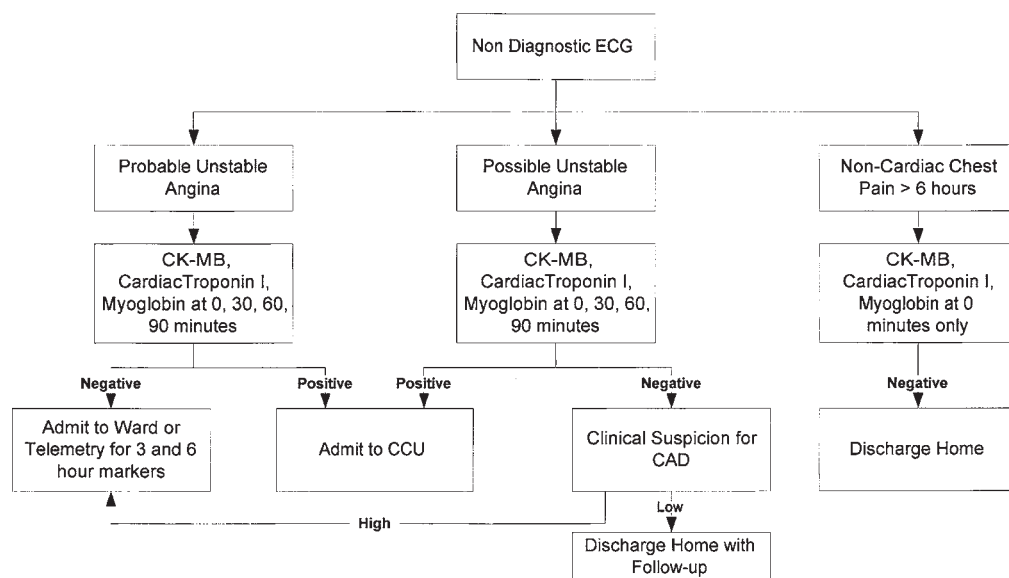
Cardiac troponin is more sensitive and specific than CK-MB for detecting myocardial necrosis and, thus, has become the preferred biomarker for the diagnosis of MI. Elevations in cardiac troponin in the absence of elevations in CK-MB suggest “microinfarctions,” wherein a relatively small amount of myocardium undergoes necrosis (17). Additionally, the finding of elevated levels of cardiac troponin is a powerful predictor of future adverse cardiac events, including death and recurrent AMI, even when elevation of CK-MB or ST-segment deviation is absent (18–20). Identification of high-risk patients has allowed emergency physicians and cardiologists to determine which patients will derive the greatest benefit from aggressive ACS therapy. Patients with positive cardiac troponin results benefit more from antithrombotics (21), glycoprotein IIb-IIIa inhibitors (22), and early invasive revascularization than do patients with normal levels of cardiac troponin (23).

The sensitivity of *initial* measurement of cardiac troponin for the diagnosis of AMI has ranged from 4 to 66% (19,24–26). Serial measurement of cardiac troponin significantly improves the ability of this cardiac biomarker to detect AMI; Hamm et al. (19) performed troponin testing upon presentation and at 4 h, with improvement in the sensitivity from 51% to 94% for troponin T and 66% to 100% for troponin I in patients without ST-elevation. In that study, patients with negative serial troponin results drawn within 4 h had a 1.1% and 0.3% rate of MI and death, respectively, at 30 d (19). The specificity of cardiac troponin for the diagnosis of MI has been reported as 89–98% (19,25). The variability in reported specificity is reflective of differences in the “gold standard” used to define AMI in those studies.

### MYOGLOBIN

Myoglobin is a low-molecular-weight, unbound, cytosolic protein that is found in both myocardial and skeletal musculature. Because of its biochemical characteristics, myoglobin can be elevated in the serum within 1 to 2 h after the onset of symptoms in patients with an AMI (27). As a result, increased concentrations of myoglobin precede elevations of CK-MB and cardiac troponin, making it ideal for rapidly establishing a diagnosis of AMI (11). Ideally, myoglobin should be obtained in patients with symptoms less than 6 h in duration. Because myoglobin can rapidly disappear within 12–36 h after the onset of symptoms, its use is limited in patients with delayed presentations (27).

The sensitivity of myoglobin for diagnosing MI in patients presenting very early after the onset of symptoms is superior to that of CK-MB; sensitivities of 55% and 23% for myoglobin and CK-MB, respectively, have been reported from measurements obtained at presentation in the ED (11). Similarly to CK-MB and cardiac troponin, the sensitivity improves with serial measurement. For example, in one study, myoglobin was found to be 14%, 90%, and 100% sensitive at 0, 3, and 6 h, respectively (28). Elevated levels of myoglobin also appear to carry prognostic information. In a study of patients with non-ST-elevation ACS,



**Fig. 1.** Rapid rule-out protocol developed by Ng and colleagues at University of California at San Diego. Patients with ST-segment deviations or unresolved chest pain were excluded from this protocol. CCU, coronary care unit. (From ref. 32.)

elevated levels of myoglobin were associated with higher 6-mo mortality (29). Myoglobin is ubiquitous in skeletal muscle; therefore, elevated levels of myoglobin may be observed in patients with skeletal muscle damage (30). Because of myoglobin's limited specificity, confirmation with a definitive cardiac biomarker such as CK-MB or cardiac troponin is recommended (16).

### *Ninety-Minute Rapid Rule-Out Protocols*

Many of the deficiencies of a single cardiac biomarker measurement may be overcome by using a combination of multiple biomarkers. In 1999, the National Academy of Clinical Biochemistry recommended that those involved in the evaluation of patients with possible ACS collectively develop an accelerated protocol for application of cardiac biomarkers. The committee recommended that the protocol include both an early sensitive cardiac biomarker that is reliably increased in the blood within 6 h of symptoms and a definitive specific cardiac biomarker that may be increased in the blood after 6–9 h (10).

Combining serum myoglobin and cardiac troponin measurements for the initial evaluation may fulfill this recommendation. Using a POC device, McCord et al. (31) measured myoglobin and cTnI at 0 and 90 min. Combined use of both markers provided 97.0% sensitivity and 59.7% specificity for AMI. A +LR of 2.41 and a –LR of 0.05 indicated that a negative cTnI and myoglobin at 90 min strongly reduced the posttest probability of AMI (31). A positive serum myoglobin level in the absence of elevated serum cTnI required additional serial cardiac biomarker measurements.

Ng et al. (32) developed a 90-min critical pathway using cTnI, myoglobin, and CK-MB (Fig. 1). Patients with nondiagnostic ECGs were stratified into probable unstable angina, possible unstable angina, and noncardiac chest pain lasting >6 h. Cardiac biomarkers were measured at presentation, and at 30, 60, and 90 min. Patients with positive cardiac

biomarkers were admitted to the hospital. A positive cTnI and an increase in myoglobin >25% over 90 min had 94% sensitivity and 98% specificity (+LR 47.0; -LR 0.06) for the diagnosis of AMI. The addition of CK-MB improved the sensitivity to 100% with a specificity of 94% for diagnosing AMI at 90 min (+LR 16.7; -LR 0). Ninety percent of dispositions from the ED could be determined at 90 min. At 30-d follow-up of discharged patients, only 0.2% were subsequently diagnosed with AMI, and 2% were eventually hospitalized with unstable angina (32).

### *Measurement of Changes in Cardiac Markers*

The sensitivity of cardiac troponin and CK-MB can be improved by measuring short-term changes in these biomarkers. Similarly, measuring changes in myoglobin over a short period of time could also improve specificity. During myocardial necrosis, a characteristic exponential rise in cardiac biomarkers of necrosis is observed and typically does not occur with other noncardiac etiologies (10).

#### **MYOGLOBIN**

Evaluating increases in myoglobin over time has the potential to be superior to using absolute concentrations. However, the results of studies testing this strategy have been mixed. Brogan et al. (11) defined a positive test as a serum myoglobin level above the diagnostic cutoff at either 0 or 1 h and reported a sensitivity of 55% and specificity of 98% (+LR 27.5; -LR 0.46) for the diagnosis of an AMI. An increase in myoglobin of 40 ng/dL over an hour was added to the definition, and the sensitivity improved to 91%, while the specificity was maintained at 96% (+LR 22.75; -LR 0.09) (11). By contrast, Montague et al. (33) defined a positive test as a myoglobin above the diagnostic cutoff at either 0 or 2 h. This method was 100% sensitive and 77% specific for AMI (+LR 4.34; -LR 0). When they defined a positive test as a doubling in myoglobin, the sensitivity decreased to 64% and the specificity improved to 98% (+LR 32; -LR 0.37) (33). Similarly, Ng et al. (32) reported that elevated myoglobin levels drawn at initial presentation and at 90 min were 70% sensitive and 80% specific (+LR 3.5; -LR 0.38) for the detection of AMI. However, measurement of an increase in 90-min myoglobin >25% improved the specificity to 98%, but with a decrease in sensitivity to 29% (+LR 14.5; -LR 0.72) (32). This variability in findings can be attributed to the type of immunoassay and diagnostic cutoff used, as well as to the definition of a positive change.

#### **CK-MB AND TROPONIN**

Measuring increases in CK-MB over a 2-h period has also been reported to be a rapid and accurate method of diagnosing AMI. Fesmire and colleagues explored the significance of 2-h changes in CK-MB and cTnI in relation to the diagnosis of AMI. Initial studies found that a 2-h change in CK-MB of >1.5 ng/dL had a sensitivity of 87.7% and a specificity of 95.8% (+LR 20.08; -LR 0.13) for the diagnosis of AMI (34). The addition of serial ECG monitoring improved the sensitivity to 94.0% with a specificity of 93.5% (+LR 14.46; -LR 0.06) (35). Fesmire and colleagues repeated the study using a different immunoassay and troponin as the “gold standard” for the diagnosis of AMI. In this follow-up study, a 2-h increase in CK-MB >0.7 ng/mL was 93.2% sensitive and 98.5% specific (+LR 62.13; -LR 0.07) for AMI. They also found that 2-h changes in CK-MB were superior to measurement of myoglobin (36). Kontos et al. (37) also studied changes in CK-MB within 3 h. They defined a positive test as either (1) 0- or 3-h CK-MB measurement above the diagnostic cutoff for AMI, (2) an increase in CK-MB by 3 ng/mL within

3 h, or (3) a doubling of CK-MB within 3 h. Using this definition, a sensitivity of 93% and a specificity of 98% (+LR 46.5; -LR 0.07) were noted for the diagnosis of AMI (37).

Two-hour changes in troponin I have also been studied. An increase of 0.2 ng/mL over 2 h has been reported to be 61.4% sensitive and 96.5% specific (+LR 17.54; -LR 0.4) for an AMI (34). This increase was also associated with a higher risk of adverse cardiac events within 30 d (38). By direct comparison, the authors found 2-h changes in CK-MB to be superior to 2-h changes in cTnI (34).

In light of the mixed results of clinical studies, diagnostic algorithms based on acute changes in cardiac biomarkers have not been widely adopted. The accuracy of these methods may be dependent on the time of the onset symptoms, because the rate at which cardiac biomarkers are released into the bloodstream may slow down later in the course of myocardial necrosis. Furthermore, the various cut points, their sensitivities, and their specificities are dependent on the immunoassay used (36,38,39). Nevertheless, it is possible that additional studies may reveal convincing clinical utility in the ED, especially when rapid decisions regarding additional testing or inpatient disposition are required.

### NOVEL MARKERS OF ISCHEMIA: POTENTIAL ROLE IN THE ED

Putative novel markers of myocardial ischemia and/or plaque instability such as human serum albumin cobalt binding, heart-type fatty acid-binding protein, C-reactive protein, and myeloperoxidase have been studied (40–44). Although their role in the ED is not yet clearly known, they are potentially useful in establishing the diagnosis and prognosis of ACS. These cardiac biomarkers represent other pathophysiological processes and do not require myocardial necrosis to be present. Many of these novel cardiac biomarkers become elevated in response to myocardial ischemia and may be useful in detecting ACS in patients early in their presentation.

### ROLE OF CARDIAC BIOMARKERS IN CHEST PAIN PROTOCOLS

Currently, myoglobin, cardiac troponin, and CK-MB detect myocardial necrosis but do not accurately detect acute myocardial ischemia in the absence of infarction (9). Several ED-based diagnostic protocols for chest pain have been developed over the past 13 yr, incorporating serial biomarker testing, serial ECGs, and provocative cardiac testing. By combining these three diagnostic modalities, diagnoses of AMI and unstable angina can be rapidly achieved in an accurate and cost-effective manner while reducing hospital admissions (5,13,45–48).

Because of the time required, performing these protocols is not feasible within the confines of the traditional ED setting. Chest pain centers have been developed as an alternative to admission, allowing prolonged observation in the ED over a 6- to 9-h period. Chest pain centers, staffed by emergency physicians and nurses, are often a geographically separate component of the ED but are usually in close proximity. Development and implementation of chest pain algorithms/centers are dependent on the resources available at the participating institution and require collaboration among emergency physicians and nurses, cardiologists, internists, and radiologists.

In most protocols, initial evaluation of patients with chest pain begins in the standard patient care area of the ED. The emergency physician must then determine the risk of ACS based on the history, physical examination, and initial 12-lead ECG. Patients who are at low to moderate risk of ACS are prime candidates for admission to the chest pain center.

Patients who have an obvious noncardiac source of chest pain are discharged home immediately. Low- to moderate-risk patients are transferred to the chest pain center for further evaluation. Patients who are recognized based on the initial evaluation as being at high risk, especially with diagnostic ECG findings, are admitted to the hospital immediately.

Chest pain protocols are typically 6–9 h long. In addition to serial biomarker testing and 12-lead ECGs, noninvasive diagnostic techniques such as rest myocardial perfusion imaging (MPI), exercise ECG testing, stress echocardiography, and stress nuclear imaging are used. The choice of test is dependent on the availability and reliability of the diagnostic modality at a particular institution. With the improvement of computer imaging and high-speed Internet access, remote interpretation can easily and reliably be performed.

### ***Graded Exercise Electrocardiography***

Exercise ECG testing is a common noninvasive diagnostic test used in the ED for low- to moderate-risk chest pain patients. It is easy to perform (49,50) and relatively safe after eliminating the possibility of rest myocardial ischemia by serial 12-lead ECGs or myocardial necrosis by serial cardiac biomarkers (51). Compared with other noninvasive cardiac imaging, exercise ECG testing is relatively inexpensive (52). A meta-analysis of protocols including exercise ECG reported a sensitivity of 68% and a specificity of 77% for the diagnosis of myocardial ischemia (+LR 3.0; –LR 0.41), which is acceptable if applied to a low-risk patient population (53). Patients with negative exercise ECG tests are discharged home with outpatient follow-up within 1 wk, whereas patients with positive and nondiagnostic tests are admitted.

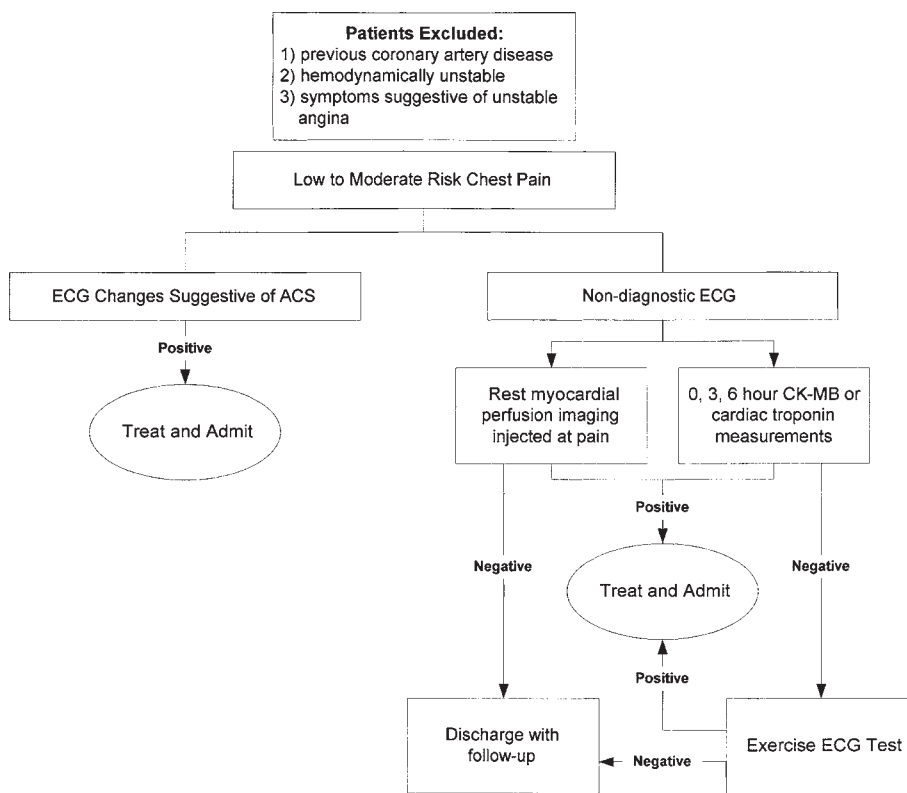
#### **CINCINNATI HEART ER STRATEGY**

Exercise ECG testing has been incorporated into a number of chest pain protocols. The Cincinnati Heart ER strategy, established in 1991, admits low- to moderate-risk chest pain patients to a chest pain unit (13). Patients with ST-segment deviation on 12-lead ECG, a history of coronary artery disease (CAD), frequent or persistent symptoms typical of unstable angina, or hemodynamic instability are excluded from this protocol. The Cincinnati Heart ER strategy was initially a 9-h protocol using serial cardiac biomarkers, continuous ST-segment monitoring, and exercise ECG testing. Patients with negative testing are discharged home with close outpatient follow-up.

In a series of 2131 patients enrolled over a 6-yr period, 309 patients were admitted as a result of the Cincinnati Heart ER program (54). Thirty percent of the admitted patients were found to have AMI or unstable angina. Of the 1822 patients discharged home, 30-d follow-up was obtained in 1696 patients. Eight revascularizations (0.47%) and one death (0.06%) occurred at 30-d follow-up, indicating that this strategy was safe and effective (54). Over the past several years, this strategy has evolved into a 6-h protocol (Fig. 2), and continuous ST-segment monitoring has been eliminated. It has been replaced by single 12-lead ECGs obtained on presentation and at 3 and 6 h. Rest MPI is available as an alternative to graded exercise testing.

#### **MAYO CLINIC CHEST PAIN PROTOCOL**

Similar protocols that have included patients with CAD have been developed at other institutions (55,56). Farkouh et al. (55) performed a randomized controlled study using a protocol that placed intermediate-risk unstable angina patients in a chest pain unit. Initial risk stratification was based on the Agency for Health Care Policy and Research



**Fig. 2.** Cincinnati Heart ER strategy. (Modified from ref. 13.)

guidelines (Table 2) (57). Unlike the Cincinnati Heart ER strategy, 13.7% of the chest pain unit population had previous AMI. These patients had cardiac biomarkers measured at 2 and 4 h, along with ST-segment trend monitoring. If the biomarker results were negative, the patient underwent exercise ECG testing or nuclear stress testing. The investigators found that by using this protocol, hospitalizations were decreased by almost 50%, with no difference in event rates when compared to the strategy of hospital admission only (55).

### COOK COUNTY HOSPITAL CHEST PAIN PROTOCOL

Zalenski et al. (56) studied 317 patients with low-risk chest pain using Goldman's chest pain algorithm (58); these patients had a nondiagnostic ECG and had chest pain that was not typical for ACS. The protocol also included patients with a history of CAD. The protocol required serial biomarkers measured at 0, 4, 8, and 12 h. If the biomarker results were negative, exercise ECG testing was performed. There were no adverse events as a result of exercise testing. The protocol was 88.8% sensitive and 47.7% specific (+LR 1.70; -LR 0.23) for AMI. For acute cardiac ischemia, the protocol was 90% sensitive and 50.5% specific (+LR 1.82; -LR 0.20). Acute cardiac ischemia was defined as positive stress echocardiogram or thallium, new ST-segment deviation, presence of a dysrhythmia, cardiogenic shock, or cardiac arrest (56).

### IMMEDIATE EXERCISE ECG TESTING—UC DAVIS PROTOCOL

Amsterdam et al. (59) evaluated a protocol implementing immediate exercise ECG testing without cardiac biomarker testing in 1000 low-risk chest pain patients (59). Patients

Table 2  
Agency for Health Care Policy and Research Risk Assessment for Unstable Angina

<i>High likelihood</i>	<i>Intermediate likelihood</i>	<i>Low likelihood</i>
<p>Any of the high or following features:</p> <ul style="list-style-type: none"> <li>• History of prior MI or sudden death or other known history of CAD</li> <li>• Definite angina: males &gt;60 or females &gt;70 yr of age</li> <li>• Transient hemodynamic or ECG changes during pain</li> <li>• Variant angina (pain with reversible ST-segment elevation)</li> <li>• ST-segment elevation or depression &gt;1 mm</li> <li>• Marked symmetrical T-wave inversion in multiple precordial leads</li> </ul>	<p>Absence of high likelihood features and any of the following:</p> <ul style="list-style-type: none"> <li>• Definite angina: males &lt;60 or females &lt;70 yr of age</li> <li>• Probable angina: males &gt;60 or females &gt;70 yr of age</li> <li>• Chest pain probably not angina in patients with diabetes</li> <li>• Chest pain probably not angina and two or three risk factors other than diabetes</li> <li>• Extracardiac vascular disease</li> <li>• ST depression of 0.05–1 mm</li> <li>• T-wave inversion &gt;1 mm in leads with dominant R-waves</li> </ul>	<p>Absence of intermediate likelihood features but may have the following:</p> <ul style="list-style-type: none"> <li>• Chest pain classified as probably not angina</li> <li>• One risk factor other than diabetes</li> <li>• T-wave flattening or inversion &lt;1 mm in leads with dominant R waves</li> <li>• Normal ECG</li> </ul>

with previously documented CAD or Q-waves were included in the study. There were no adverse events as a result of exercise testing. Six hundred forty patients (64%) had negative exercise stress tests. Of the 582 discharged patients available for 30-d follow-up, one patient (0.17%) had a non-ST-elevation AMI, and another patient had a positive myocardial stress scintigraphy (0.17%). Nondiagnostic stress tests were seen in 235 patients (23.5%). No AMIs were diagnosed in these patients, but seven patients (3.0%) underwent revascularizations. One hundred twenty-five (12.5%) patients had positive exercise stress tests; of these, 4 patients had AMI (3.2%) and 12 patients had revascularizations (9.6%). The four patients with AMI had positive cardiac biomarkers obtained at presentation but received exercise ECG testing before the elevated cardiac biomarkers were known. As a result, the investigators recommended obtaining one set of cardiac biomarkers to maximize safety (59).

### ***Rest MPI***

Rest MPI has been integrated into a number of chest pain protocols. MPI uses <sup>99m</sup>technetium sestamibi and tetrofosmin, which are absorbed by viable myocardium by means of passive diffusion through the mitochondrial membrane. The amount of radionuclide uptake is proportional to coronary artery blood flow. Because its half-life is longer than 7 h and redistribution is limited, patients can be imaged several hours after injection. MPI can be performed immediately after the initial evaluation and with the tracer typically injected while the patient has pain at rest. If the patient is pain-free, the American Society of Nuclear Cardiology recommends that <sup>99m</sup>technetium injections be given up to 2 h after the cessation of pain (60). Rest MPI is ideal for patients at low to moderate risk of ACS.



Compared with initial serum cardiac biomarkers, rest MPI is more sensitive for detecting AMI. In one study, rest MPI was 92% sensitive whereas the initial cTnI was only 39% sensitive in low- to moderate-risk patients with chest pain (26). The additional benefit of rest MPI is the detection of myocardial ischemia before necrosis is present (26). Rest MPI also predicts 30-d AMI and revascularization with a reported sensitivity of 82% and a specificity of 83% (+LR 4.81; -LR 0.22) (46). In addition to being cost-effective, this diagnostic tool improves physician decision making, reducing hospital admissions up to 10% (61).

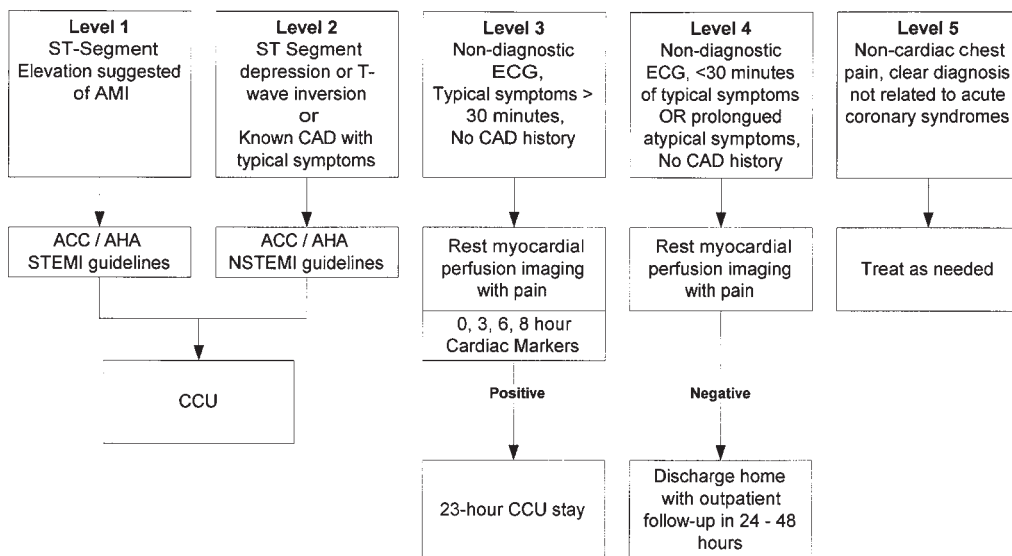
Serial cardiac biomarker testing and rest MPI offer complementary information. Kontos et al. (62) found that only 76% of patients with positive serial cTnI had a positive myocardial perfusion image. In a study of 620 low- to moderate-risk chest pain patients, 5 patients with AMI had a negative rest MPI. However, four of these five patients had positive serial cTnI measurements (26). Patients with positive serial cTnI but a negative rest MPI tended to have a higher prevalence of insignificant CAD and a smaller infarct size (62). This discrepancy may exist because a minimum of 3–5% myocardial involvement is required to be detected by MPI (63).

Rest MPI has some advantages over the other aforementioned methods. The test is performed at rest and is not dependent on the patient's ability to ambulate. Rest MPI also has the ability to detect unstable angina (i.e., ischemia in the absence of necrosis) and may provide earlier diagnosis of AMI compared with serial cardiac biomarker testing. However, there are limitations to rest MPI. The specificity has been reported to be 67% and, therefore, there are a relatively high number of false positives (26). Because rest MPI is reflective of myocardial tissue viability, patients with previous AMI will have an abnormal rest MPI. For this reason, this patient population is excluded from chest pain protocols implementing rest MPI, and these patients require other testing to confirm acute myocardial ischemia or AMI.

#### MEDICAL COLLEGE OF VIRGINIA CHEST PAIN PROTOCOL

The Medical College of Virginia Hospitals of the Virginia Commonwealth University have developed a comprehensive strategy incorporating MPI using a five-level approach to the evaluation of chest pain (Fig. 3) (46). Patients categorized in levels 1 and 2 are considered to be at high risk of AMI or unstable angina and are admitted to an intensive care unit for appropriate treatment. Level 5 patients are considered to be at very low risk of AMI or unstable angina and are discharged without any further cardiac testing. Patients assigned to level 3 have typical symptoms lasting >30 min but have nondiagnostic ECGs and no history of CAD. Level 3 patients are considered to be at moderate risk of AMI or unstable angina. These patients undergo immediate MPI performed in conjunction with serial ECGs and cardiac biomarkers performed at 0, 3, 6, and 8 h. If the MPI and serial cardiac biomarkers are both negative, level 3 patients are referred for stress imaging within 12–24 h. Level 4 patients have typical symptoms lasting <30 min or prolonged atypical chest pain. The ECG is nondiagnostic, and a history of CAD is absent. These patients are considered to be at low to moderate risk and receive immediate MPI without serial cardiac biomarker testing. If results are negative, these patients are discharged without serial cardiac biomarkers and with a follow-up evaluation scheduled within 48 h. Any patient with a positive MPI or positive cardiac biomarkers is treated and becomes retriaged to the level 2 category.

Using this strategy, Tatum et al. (46) enrolled 1187 consecutive patients. Among level 3 patients, 3% were diagnosed with AMI and 17% underwent index revascularization.



**Fig. 3.** Medical College of Virginia Chest Pain Protocol. Patients with a previous history of AMI are not eligible to receive rest MPI. (Modified from refs. 46.) CCU, coronary care unit; STEMI, ST-elevation myocardial infarction; NSTEMI, non-ST-elevation myocardial infarction.

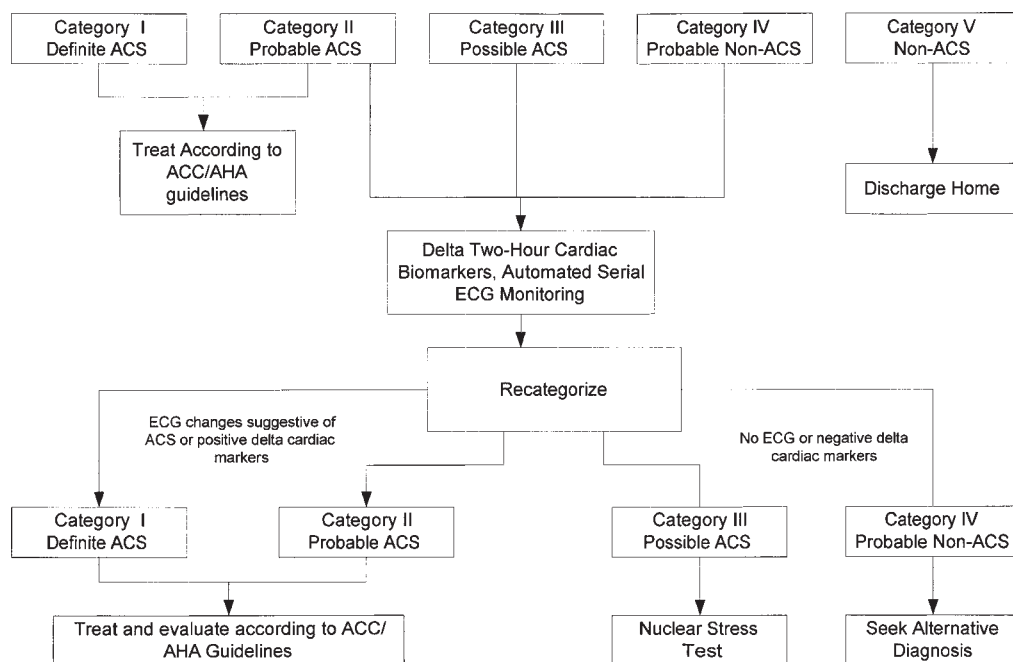
Among patients categorized as level 4, only 0.7% had AMI and 2.5% received index revascularization. Of note, all patients diagnosed with AMI had abnormal MPIs. Overall, the chest pain protocol was 92% sensitive and 100% specific (+LR >100; -LR 0.08) for AMI. This strategy also appeared to be cost-effective. Although the cost for individual ED visits increased, it was offset by a decrease in hospital admissions, shorter length of stay, and a more effective use of coronary angiography, thus decreasing overall costs (45,46).

### ***Pharmacological Stress Testing and Noninvasive Imaging***

Graded exercise electrocardiography has its limitations in patients who have baseline ECG abnormalities or who are unable to ambulate. Additionally, rest MPI cannot be performed in patients with previous AMI. In these patients, stress testing with echocardiography or nuclear scintigraphy can be alternative solutions. Similarly, for patients who are unable to exercise, pharmacological methods are available. These techniques offer more diagnostic information than exercise ECG testing but may be offset by higher costs, especially when applied to the low-risk patient population (64). Because there are few studies evaluating stress nuclear scintigraphy and stress echocardiography in the ED setting, it is unclear whether or not the increased diagnostic accuracy will offset the cost of these tests in the low-risk patient population.

#### **DOBUTAMINE STRESS ECHOCARDIOGRAPHY**

Dobutamine stress echocardiography (DSE) is an alternative for patients who are unable to perform graded exercise testing. The incidence of AMI or ventricular dysrhythmia is approx 1/2000, but no deaths have been reported. Bholasingh et al. (65) studied 404 low-risk patients who underwent DSE after negative cTnT measurements 12 h after the onset of symptoms. Patients with previous CAD were included in this analysis. Twenty-three (5.7%) patients were removed from the study because of poor echocardiographic images.



**Fig. 4.** Erlanger Chest Pain Protocol using nuclear stress testing (From ref. 47.)

Thirty-nine patients (10.3%) could not finish the study because of intolerable side effects, which were defined as dysrhythmia and severe hypotension or hypertension. Patients with positive DSE had a sevenfold increased risk of cardiac death, AMI, rehospitalization for unstable angina, or revascularization within 6 mo. In those patients with a negative DSE, one cardiac death was reported (0.3%) and seven patients underwent revascularizations (2%). No patients with AMI, however, were observed at 6-mo follow-up (65). Although DSE appears to be an effective means for risk stratification, its cost-effectiveness in the ED setting is not known. It is also important for the institution to have on staff physicians who are interested in DSE and have expertise in this methodology.

#### ERLANGER CHEST PAIN PROTOCOL

Fesmire et al. (47) have developed a novel chest pain protocol incorporating 2-h changes in CK-MB and cTnI with stress nuclear imaging (Fig. 4). In their protocol, patients with chest pain are initially stratified into five categories based on initial history, physical examination, and 12-lead ECG (Table 3). Category I and II patients are considered to be at high risk of ACS and are treated according to published American College of Cardiology/American Heart Association (ACC/AHA) guidelines. Any treatment decisions for patients in categories III and IV are left up to the treating physician.

Patients not undergoing emergency reperfusion therapy are then evaluated for 2 h, which includes ST-segment monitoring with serial ECGs, and baseline and 2-h CK-MB/cardiac troponin levels. After 2 h, these patients are recategorized to one of three risk categories (Table 4). Patients with a positive delta CK-MB, defined as an increase of 1.5 ng/mL or greater, or a positive delta cTnI, defined as an increase of 0.2 ng/mL or greater, are placed in category II. Patients without significant increases in CK-MB and cTnI are placed in categories III and IV. Patients reassigned to category III have nuclear stress

Table 3  
Initial Risk Stratification into Five Categories Using Erlanger Chest Pain Protocol

Category	Presence of ACS	ECG	Treatment
I	Definite	Diagnostic	Treat according to ACC/AHA guidelines.
II	Probable	Nondiagnostic	Treat according to ACC/AHA guidelines.
III	Possible	Nondiagnostic	Treatment is at discretion of physician.
IV	Probably non-ACS but previous history of CAD or significant risk factors	Nondiagnostic	Treatment is at discretion of physician.
V	Obvious noncardiac chest pain and absence of risk factors	Nondiagnostic	Discharge home.

Table 4  
Recategorization into Three Categories After 2 h of Observation Using Erlanger Chest Pain Protocol

Category	Risk	Delta CK-MB or cTnI	Serial ECG changes diagnostic of ACS	Action taken after recategorization
II	Intermediate to high	Yes	Yes	Treat based on ACC/AHA guidelines. Admit with repeat 6-h cardiac marker testing and stress testing.
III	Low	No	No	Stress testing.
IV	Very low	No	No	Discharge home.

imaging. Initial resting scans are performed using thallium-201. If the rest images are negative, stress nuclear imaging is performed using <sup>99m</sup>Techetium. Stress testing is achieved by exercise, adenosine infusion, dipyridamole infusion, or dobutamine infusion customized for the individual patient. Patients reassigned to category IV are discharged home without further testing (47).

The outcomes of the 2074 patients enrolled this protocol have been reported (47). Crossover from one category to another occurred in 14.5%, 43.9%, and 10.1% of the patients originally assigned to categories II, II, and IV respectively, based on changes seen in serial ECG monitoring or 2-h changes in cardiac biomarkers. For the detection of AMI, the protocol was 100% sensitive and 81.9% specific (+LR 5.5; -LR 0). For the detection of 30-d ACS, the protocol was 99.1% sensitive and 87.4% specific (+LR 7.9; -LR 0.01). Although these results are compelling, the cost-effectiveness of this protocol is unknown.

## CONCLUSION

Rapid and accurate evaluation of chest pain remains a challenge within the ED setting. Although 12-lead ECG, history, and physical examination remain cornerstones of the initial evaluation of chest pain, these methods are insensitive. The incorporation of cardiac biomarkers including cardiac troponin, CK-MB, and myoglobin into clinical protocols

have improved the diagnosis of AMI. Elevations in cardiac troponin provide the clinician with important prognostic information and assist in identifying patients who will benefit most from aggressive management of ACS.

The initial sensitivity of these cardiac biomarkers is relatively poor for the diagnosis of AMI but improves with serial testing over a period of 6–8 h. Myoglobin rises rapidly within 1 to 2 h after the onset of AMI, and its early sensitivity is excellent. However, its lack of specificity limits its benefit when used alone, requiring more specific markers such as CK-MB or cardiac troponins to be used in combination. Numerous strategies attempting to shorten the time required to make a biochemical diagnosis of AMI have been studied. Ninety-minute protocols combining myoglobin and cTnI appear to exclude AMI effectively. Measurement of 2-h changes in cTnI and CK-MB have also been studied. Preliminary studies suggest that when these tests are negative, the likelihood of AMI is strongly decreased.

Because cardiac biomarkers are released in the presence of myocardial necrosis, these tests are not adequate in ruling out acute myocardial ischemia. In an effort to improve the diagnosis of ACS, chest pain protocols combining cardiac biomarker testing and rest MPI or provocative cardiac testing have been developed for the low- to moderate-risk patient population. These protocols appear to be safe, effective in reducing admissions, and cost-effective, while identifying higher-risk patients needing further testing or treatment. Protocols using more expensive tests, such as stress echocardiography or stress nuclear imaging, appear at least equally effective, if not superior. The cost-effectiveness of these methods has yet to be determined.

## REFERENCES

1. Braunwald E, Antman EM, Beasley JW, et al. ACC/AHA 2002 guideline update for the management of patients with unstable angina and non-ST-segment elevation myocardial infarction—summary article: a report of the American College of Cardiology/American Heart Association task force on practice guidelines (Committee on the Management of Patients with Unstable Angina). *J Am Coll Cardiol* 2002;40(7):1366–1374.
2. Nourjah P. National Hospital Ambulatory Medical Care Survey: 1997 emergency department summary. *Adv Data* 1999(304):1–24.
3. Pope JH, Ruthazer R, Beshansky JR, Griffith JL, Selker HP. Clinical features of emergency department patients presenting with symptoms suggestive of acute cardiac ischemia: a multicenter study. *J Thromb Thrombolysis* 1998;6(1):63–74.
4. Newby LK, Storrow AB, Gibler WB, et al. Bedside multimarker testing for risk stratification in chest pain units: the chest pain evaluation by creatine kinase-MB, myoglobin, and troponin I (CHECKMATE) study. *Circulation* 2001;103(14):1832–1837.
5. Graff LG, Dallara J, Ross MA, et al. Impact on the care of the emergency department chest pain patient from the chest pain evaluation registry (CHEPER) study. *Am J Cardiol* 1997;80(5):563–568.
6. Karlson BW, Herlitz J, Richter A, Sjolín M, Hjalmarson A. Prognosis in patients with ST-T changes but no rise in serum enzyme activity as compared with non-Q-wave infarction. *Cardiology* 1991;79(4):271–279.
7. Gibler WB, Young GP, Hedges JR, et al. Acute myocardial infarction in chest pain patients with nondiagnostic ECGs: serial CK-MB sampling in the emergency department. The Emergency Medicine Cardiac Research Group. *Ann Emerg Med* 1992;21(5):504–512.
8. Panju AA, Hemmelgarn BR, Guyatt GH, Simel DL. The rational clinical examination: is this patient having a myocardial infarction? *JAMA* 1998;280(14):1256–1263.
9. Balk EM, Ioannidis JP, Salem D, Chew PW, Lau J. Accuracy of biomarkers to diagnose acute cardiac ischemia in the emergency department: a meta-analysis. *Ann Emerg Med* 2001;37(5):478–494.
10. Wu AH, Apple FS, Gibler WB, Jesse RL, Warshaw MM, Valdes R Jr. National Academy of Clinical Biochemistry Standards of Laboratory Practice: recommendations for the use of cardiac markers in coronary artery diseases. *Clin Chem* 1999;45(7):1104–1121.

11. Brogan GX Jr, Friedman S, McCuskey C, et al. Evaluation of a new rapid quantitative immunoassay for serum myoglobin versus CK-MB for ruling out acute myocardial infarction in the emergency department. *Ann Emerg Med* 1994;24(4):665–671.
12. Young GP, Gibler WB, Hedges JR, et al. Serial creatine kinase-MB results are a sensitive indicator of acute myocardial infarction in chest pain patients with nondiagnostic electrocardiograms: the second Emergency Medicine Cardiac Research Group Study. *Acad Emerg Med* 1997;4(9):869–877.
13. Gibler WB, Runyon JP, Levy RC, et al. A rapid diagnostic and treatment center for patients with chest pain in the emergency department. *Ann Emerg Med* 1995;25(1):1–8.
14. Lott JA. Serum enzyme determinations in the diagnosis of acute myocardial infarction: an update. *Hum Pathol* 1984;15(8):706–716.
15. Capellan O, Hollander JE, Pollack C Jr, et al. Prospective evaluation of emergency department patients with potential coronary syndromes using initial absolute CK-MB vs. CK-MB relative index. *J Emerg Med* 2003;24(4):361–367.
16. Alpert JS, Thygesen K, Antman E, Bassand JP. Myocardial infarction redefined—a consensus document of The Joint European Society of Cardiology/American College of Cardiology Committee for the redefinition of myocardial infarction. *J Am Coll Cardiol* 2000;36(3):959–969.
17. Apple FS, Falahati A, Paulsen PR, Miller EA, Sharkey SW. Improved detection of minor ischemic myocardial injury with measurement of serum cardiac troponin I. *Clin Chem* 1997;43(11):2047–2051.
18. Antman EM, Tanasijevic MJ, Thompson B, et al. Cardiac-specific troponin I levels to predict the risk of mortality in patients with acute coronary syndromes. *N Engl J Med* 1996;335(18):1342–1349.
19. Hamm CW, Goldmann BU, Heeschen C, Kreyman G, Berger J, Meinertz T. Emergency room triage of patients with acute chest pain by means of rapid testing for cardiac troponin T or troponin I. *N Engl J Med* 1997;337(23):1648–1653.
20. Ohman EM, Armstrong PW, Christenson RH, et al. Cardiac troponin T levels for risk stratification in acute myocardial ischemia: GUSTO IIA Investigators. *N Engl J Med* 1996;335(18):1333–1341.
21. Lindahl B, Venge P, Wallentin L. Troponin T identifies patients with unstable coronary artery disease who benefit from long-term antithrombotic protection. Fragmin in Unstable Coronary Artery Disease (FRISC) Study Group. *J Am Coll Cardiol* 1997;29(1):43–48.
22. Newby LK, Ohman EM, Christenson RH, et al. Benefit of glycoprotein IIb/IIIa inhibition in patients with acute coronary syndromes and troponin t-positive status: the paragon-B troponin T substudy. *Circulation* 2001;103(24):2891–2896.
23. Morrow DA, Cannon CP, Rifai N, et al. Ability of minor elevations of troponins I and T to predict benefit from an early invasive strategy in patients with unstable angina and non-ST elevation myocardial infarction: results from a randomized trial. *JAMA* 2001;286(19):2405–2412.
24. Gust R, Gust A, Bottiger BW, Bohrer H, Martin E. Bedside troponin T testing is not useful for early out-of-hospital diagnosis of myocardial infarction. *Acta Anaesthesiol Scand* 1998;42(4):414–417.
25. Tucker JF, Collins RA, Anderson AJ, Hauser J, Kalas J, Apple FS. Early diagnostic efficiency of cardiac troponin I and troponin T for acute myocardial infarction. *Acad Emerg Med* 1997;4(1):13–21.
26. Kontos MC, Jesse RL, Anderson FP, Schmidt KL, Ornato JP, Tatum JL. Comparison of myocardial perfusion imaging and cardiac troponin I in patients admitted to the emergency department with chest pain. *Circulation* 1999;99(16):2073–2078.
27. McComb JM, McMaster EA, Jadgey AA. Myoglobin in the very early phase of acute myocardial infarction. *Ann Clin Biochem* 1985;22(Pt 2):152–155.
28. Gibler WB, Gibler CD, Weinshenker E, et al. Myoglobin as an early indicator of acute myocardial infarction. *Ann Emerg Med* 1987;16(8):851–856.
29. de Lemos JA, Morrow DA, Gibson CM, et al. The prognostic value of serum myoglobin in patients with non-ST-segment elevation acute coronary syndromes: results from the TIMI 11B and TACTICS-TIMI 18 studies. *J Am Coll Cardiol* 2002;40(2):238–244.
30. Siegel AJ, Sholar M, Yang J, Dhanak E, Lewandowski KB. Elevated serum cardiac markers in asymptomatic marathon runners after competition: is the myocardium stunned? *Cardiology* 1997;88(6):487–491.
31. McCord J, Nowak RM, McCullough PA, et al. Ninety-minute exclusion of acute myocardial infarction by use of quantitative point-of-care testing of myoglobin and troponin I. *Circulation* 2001;104(13):1483–1488.
32. Ng SM, Krishnaswamy P, Morissey R, Clopton P, Fitzgerald R, Maisel AS. Ninety-minute accelerated critical pathway for chest pain evaluation. *Am J Cardiol* 2001;88(6):611–617.
33. Montague C, Kircher T. Myoglobin in the early evaluation of acute chest pain. *Am J Clin Pathol* 1995;104(4):472–476.

34. Fesmire FM. Delta CK-MB outperforms delta troponin I at 2 hours during the ED rule out of acute myocardial infarction. *Am J Emerg Med* 2000;18(1):1–8.
35. Fesmire FM. A rapid protocol to identify and exclude acute myocardial infarction: continuous 12-lead ECG monitoring with 2-hour delta CK-MB. *Am J Emerg Med* 2000;18(6):698–702.
36. Fesmire FM, Christenson RH, Fody EP, Feintuch TA. Delta creatine kinase-MB outperforms myoglobin at two hours during the emergency department identification and exclusion of troponin positive non-ST-segment elevation acute coronary syndromes. *Ann Emerg Med* 2004;44(1):12–19.
37. Kontos MC, Anderson FP, Schmidt KA, Ornato JP, Tatum JL, Jesse RL. Early diagnosis of acute myocardial infarction in patients without ST-segment elevation. *Am J Cardiol* 1999;83(2):155–158.
38. Fesmire FM, Fesmire CE. Improved identification of acute coronary syndromes with second generation cardiac troponin I assay: utility of 2-hour delta cTnI  $> \text{ or } = +0.02 \text{ ng/mL}$ . *J Emerg Med* 2002;22(2):147–152.
39. Fesmire FM. Improved identification of acute coronary syndromes with delta cardiac serum marker measurements during the emergency department evaluation of chest pain patients. *Cardiovasc Toxicol* 2001;1(2):117–123.
40. Brennan ML, Penn MS, Van Lente F, et al. Prognostic value of myeloperoxidase in patients with chest pain. *N Engl J Med* 2003;349(17):1595–1604.
41. Morrow DA, de Lemos JA, Sabatine MS, et al. Evaluation of B-type natriuretic peptide for risk assessment in unstable angina/non-ST-elevation myocardial infarction: B-type natriuretic peptide and prognosis in TACTICS-TIMI 18. *J Am Coll Cardiol* 2003;41(8):1264–1272.
42. Christenson RH, Duh SH, Sanhai WR, et al. Characteristics of an Albumin Cobalt Binding Test for assessment of acute coronary syndrome patients: a multicenter study. *Clin Chem* 2001;47(3):464–470.
43. Morrow DA, Rifai N, Antman EM, et al. C-reactive protein is a potent predictor of mortality independently of and in combination with troponin T in acute coronary syndromes: a TIMI 11A substudy. *Thrombolysis in Myocardial Infarction*. *J Am Coll Cardiol* 1998;31(7):1460–1465.
44. Glatz JF, van der Vusse GJ, Simoons ML, Kragten JA, van Dieijen-Visser MP, Hermens WT. Fatty acid-binding protein and the early detection of acute myocardial infarction. *Clin Chim Acta* 1998;272(1):87–92.
45. Kontos MC, Schmidt KL, McCue M, et al. A comprehensive strategy for the evaluation and triage of the chest pain patient: a cost comparison study. *J Nucl Cardiol* 2003;10(3):284–290.
46. Tatum JL, Jesse RL, Kontos MC, et al. Comprehensive strategy for the evaluation and triage of the chest pain patient. *Ann Emerg Med* 1997;29(1):116–125.
47. Fesmire FM, Hughes AD, Fody EP, et al. The Erlanger chest pain evaluation protocol: a one-year experience with serial 12-lead ECG monitoring, two-hour delta serum marker measurements, and selective nuclear stress testing to identify and exclude acute coronary syndromes. *Ann Emerg Med* 2002;40(6):584–594.
48. Stowers SA, Eisenstein EL, Th Wackers FJ, et al. An economic analysis of an aggressive diagnostic strategy with single photon emission computed tomography myocardial perfusion imaging and early exercise stress testing in emergency department patients who present with chest pain but nondiagnostic electrocardiograms: results from a randomized trial. *Ann Emerg Med* 2000;35(1):17–25.
49. Stuart RJ Jr, Ellestad MH. National survey of exercise stress testing facilities. *Chest* 1980;77(1):94–97.
50. Stein RA, Chaitman BR, Balady GJ, et al. Safety and utility of exercise testing in emergency room chest pain centers: an advisory from the Committee on Exercise, Rehabilitation, and Prevention, Council on Clinical Cardiology, American Heart Association. *Circulation* 2000;102(12):1463–1467.
51. Stein RA, Chaitman BR, Balady GJ, et al. Safety and utility of exercise testing in emergency room chest pain centers: an advisory from the Committee on Exercise, Rehabilitation, and Prevention, Council on Clinical Cardiology, American Heart Association. *Circulation* 2000;102(12):1463–1467.
52. Gibbons RJ, Balady GJ, Beasley JW, et al. ACC/AHA guidelines for exercise testing: a report of the American College of Cardiology/American Heart Association Task Force on Practice Guidelines (Committee on Exercise Testing). *J Am Coll Cardiol* 1997;30(1):260–311.
53. Detrano R, Gianrossi R, Froelicher V. The diagnostic accuracy of the exercise electrocardiogram: a meta-analysis of 22 years of research. *Prog Cardiovasc Dis* 1989;32(3):173–206.
54. Storrow AB, Gibler WB, Walsh RA. An emergency department chest pain rapid diagnosis and treatment unit: results from a six year experience [abstract]. *Circulation* 1998;98:I–425.
55. Farkouh ME, Smars PA, Reeder GS, et al. A clinical trial of a chest-pain observation unit for patients with unstable angina. Chest Pain Evaluation in the Emergency Room (CHEER) Investigators. *N Engl J Med* 1998;339(26):1882–1888.

56. Zalenski RJ, McCarren M, Roberts R, et al. An evaluation of a chest pain diagnostic protocol to exclude acute cardiac ischemia in the emergency department. *Arch Intern Med* 1997;157(10):1085–1091.
57. Braunwald E, Mark DB, Jones RH, et al. *Diagnosing and Managing Unstable Angina: Quick Reference Guide for Clinicians*, No. 10 (AHCPR publication no 94-0602 1994). National Heart, Lung, and Blood Institute, Rockville, MD, 1994.
58. Goldman L, Cook EF, Brand DA, et al. A computer protocol to predict myocardial infarction in emergency department patients with chest pain. *N Engl J Med* 1988;318(13):797–803.
59. Amsterdam EA, Kirk JD, Diercks DB, Lewis WR, Turnipseed SD. Immediate exercise testing to evaluate low-risk patients presenting to the emergency department with chest pain. *J Am Coll Cardiol* 2002;40(2):251–256.
60. Wackers FJ, Brown KA, Heller GV, et al. American Society of Nuclear Cardiology position statement on radionuclide imaging in patients with suspected acute ischemic syndromes in the emergency department or chest pain center. *J Nucl Cardiol* 2002;9(2):246–250.
61. Udelson JE, Beshansky JR, Ballin DS, et al. Myocardial perfusion imaging for evaluation and triage of patients with suspected acute cardiac ischemia: a randomized controlled trial. *JAMA* 2002;288(21):2693–2700.
62. Kontos MC, Fratkin MJ, Jesse RL, Anderson FP, Ornato JP, Tatum JL. Sensitivity of acute rest myocardial perfusion imaging for identifying patients with myocardial infarction based on a troponin definition. *J Nucl Cardiol* 2004;11(1):12–19.
63. Verani MS, Jeroudi MO, Mahmarian JJ, et al. Quantification of myocardial infarction during coronary occlusion and myocardial salvage after reperfusion using cardiac imaging with technetium-99m hexakis 2-methoxyisobutyl isonitrile. *J Am Coll Cardiol* 1988;12(6):1573–1581.
64. Lee TH, Boucher CA. Clinical practice: noninvasive tests in patients with stable coronary artery disease. *N Engl J Med* 2001;344(24):1840–1845.
65. Bholasingh R, Cornel JH, Kamp O, et al. Prognostic value of pre-discharge dobutamine stress echocardiography in chest pain patients with a negative cardiac troponin T. *J Am Coll Cardiol* 2003;41(4):596–602.





# 5

---

## Cardiac Troponin for Risk Assessment and Management of Non-ST-Elevation Acute Coronary Syndrome

---

*Bertil Lindahl, MD, PhD, FESC*

### CONTENTS

DEFINITION OF NON-ST-ELEVATION ACUTE CORONARY SYNDROME
THE CLINICAL PROBLEM
THE DIAGNOSTIC CHALLENGE
THE PROGNOSTIC CHALLENGE
THE THERAPEUTIC CHALLENGE
MECHANISMS UNDERLYING PROGNOSTIC RELATIONSHIP OF TROPONIN IN ACS
PRACTICAL ISSUES
CONCLUSION
REFERENCES

---

### SUMMARY

The clinical history, standard 12-lead electrocardiogram (ECG), and markers of myocardial necrosis constitute the basis for diagnosis and accurate risk assessment in patients with suspected of a non-ST-elevation acute coronary syndrome (NSTEACS). Cardiac troponin T and cardiac troponin I are ideal biochemical markers for the detection of myocardial necrosis in unstable patients who have repeated episodes of ischemia of varying intensity and several days' duration, owing to their high sensitivity and specificity and their long duration of elevation. The troponins are independently predictive of mortality as well as of new or recurrent acute myocardial infarction after an episode of NSTEACS. By integrating the clinical history, ECG findings, and troponin results, it is possible to stratify the patients into low-, intermediate-, and high-risk groups. In addition, troponin results are useful for selecting patients who benefit from treatment with low-molecular-weight heparin, glycoprotein IIb/IIIa antagonists, and invasive management.

**Key Words:** Non-ST-elevation acute coronary syndrome; acute myocardial infarction; unstable angina; troponin T; troponin C; electrocardiogram; diagnosis; risk assessment.

From: *Contemporary Cardiology:  
Cardiovascular Biomarkers: Pathophysiology and Disease Management*  
Edited by: David A. Morrow © Humana Press Inc., Totowa, NJ

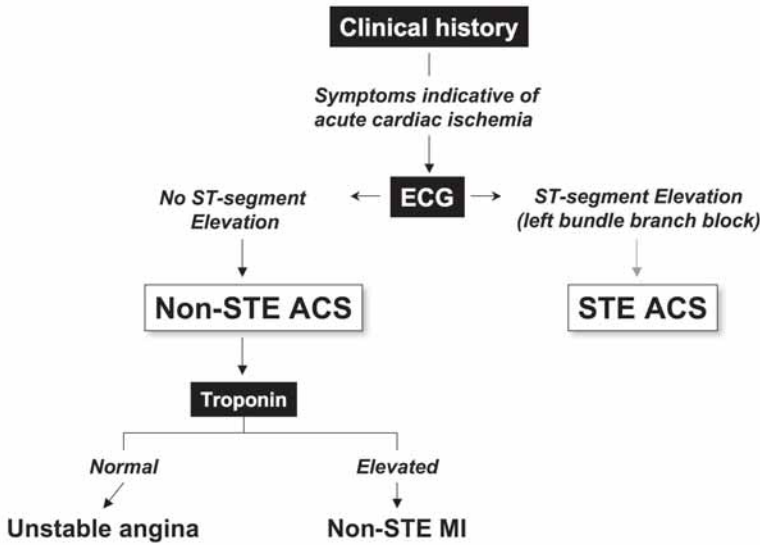


Fig. 1. Definition of ACS.

## DEFINITION OF NON-ST-ELEVATION ACUTE CORONARY SYNDROME

Although acute coronary syndrome (ACS) constitutes a continuum, it is usually divided into ST-elevation ACS (STEACS) and non-ST-elevation ACS (NSTEACS) according to the electrocardiogram (ECG) changes at presentation (Fig. 1). Patients presenting with symptoms of acute cardiac ischemia and ST-elevation on the ECG are referred to as having STEACS. Owing to the high specificity of ST-elevation, STEACS is, in practice, equivalent to ST-elevation myocardial infarction (STEMI). Patients presenting with new left bundle branch block, which prevents evaluation of the ST-segment, should be treated similarly to those with ST-elevation. Patients with other or no ischemic ECG changes are referred to as having non-STEACS. The NSTEACS group is further divided into non-ST-elevation myocardial infarction (NSTEMI) and unstable angina, based on the presence or absence of myocardial necrosis.

## THE CLINICAL PROBLEM

For patients presenting with chest pain or other symptoms suggestive of NSTEACS, there is a broad spectrum of diagnoses, including chest pain of noncardiac causes, unstable angina, and myocardial infarction (MI) of varying size, with diverse prognoses and appropriate treatments. These patients must be considered to have an ACS until proven otherwise. Of those admitted to the hospital, <10% will have STEMI, approx 50% will have a NSTEACS, and the remaining approx 40% will have diagnoses other than ACS. The annual admission rate for NSTEACS is approx 3500–4000 per 1 million inhabitants.

In patients with a diagnosis of NSTEACS, the in-hospital and 6-mo postdischarge mortality is approx 3% and 5%, respectively, and approx 20% are rehospitalized for heart disease during the first 6 mo (1,2). However, the prognosis differs considerably within the population presenting with NSTEACS. Furthermore, a broad number of evidence-based

Table 1  
Possible Causes of Elevations of Cardiac Troponins<sup>a</sup>

---

Primary ischemic cardiac injury
Thrombotic/embolic coronary occlusion (STEMI/NSTEMI)
Secondary ischemic cardiac injury
Coronary intervention (PCI/CABG)
Sympathomimetics (cocaine, catecholamine storm)
Pulmonary embolus (presumed right heart strain or hypoxia)
Coronary artery spasm
Coronary artery inflammation (vasculitis)
Prolonged tachyarrhythmia
Acute heart failure
Extreme endurance exercise
Nonischemic cardiac injury
Myocarditis (infection, autoimmune, drugs)
Cardiac trauma
Metabolic/toxic (renal failure, septic shock, drugs)

---

<sup>a</sup>From ref. 7. PCI, percutaneous coronary intervention; CABG, coronary artery bypass graft.

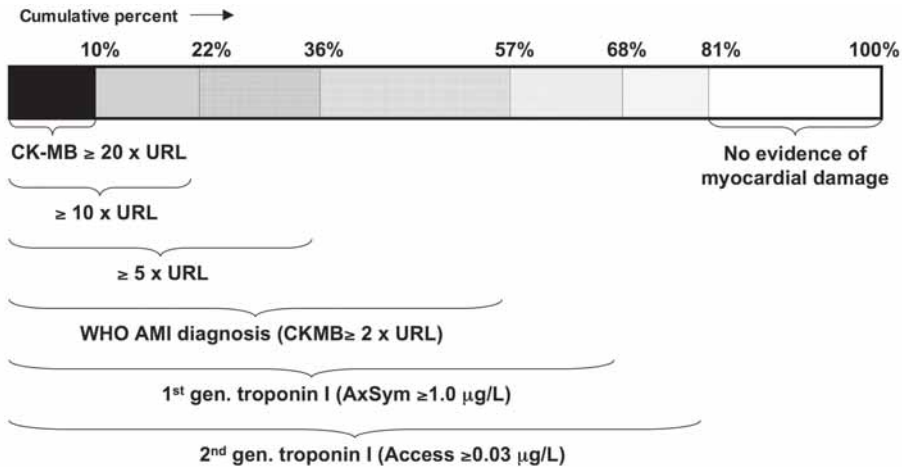
treatments have become available in the last 10–15 yr. Therefore, early risk assessment is important in order to choose appropriate therapeutic strategies. This risk assessment should be “precise, reliable and, preferably, easily and rapidly available at low cost” (3).

In the early 1990s, studies showed, for the first time, that creatine kinase (CK)-MB (mass) and troponins were frequently elevated in patients considered at the time to have presented with unstable angina, and that these elevations are associated with an adverse prognosis (4–6). Since then, markers of myocardial damage in general, and the troponins in particular, have become central elements in early risk assessment of patients with NSTEMACS.

## THE DIAGNOSTIC CHALLENGE

The separation of a diagnosis of NSTEMI from unstable angina is dependent on the ability to show myocardial necrosis. Cardiac troponin T (cTnT) and cardiac troponin I (cTnI) are ideal biochemical markers for detection of myocardial necrosis owing to their high sensitivity and specificity and their wide time window (i.e., there is a long duration of elevated plasma levels after myocardial damage). These properties make the troponins especially suitable for detection of quantitatively small amounts of myocardial damage in unstable patients. However, it is important to remember that an elevated level of troponin in blood signals only that myocardial damaged has occurred *and does not indicate the cause of the damage*. A number of other possible reasons for myocardial damage besides ischemia owing to a thrombotic or embolic occlusion of a coronary artery (Table 1) must be considered, and, thus, an abnormal troponin result must be interpreted in light of the clinical picture, rather than the other way around.

The introduction of troponins as part of the diagnostic arsenal has revealed that patients with NSTEMACS have myocardial damage more frequently than previously thought, although in many cases the damage is quantitatively small. With the use of second- and third-generation troponin assays, with their increased diagnostic sensitivity, myocardial damage



**Fig. 2.** Proportions of population with NSTEMACS and elevated levels of CK-MB and cTnI (using two different assays) using different cut points. Unpublished data are from the FRISC-II study. WHO, World Health Organization; URL, upper reference limit.

is detected in an even higher proportion of NSTEMACS patients (Fig. 2). Moreover, adoption of the new European Society of Cardiology/American College of Cardiology (ESC/ACC) criteria for the diagnosis of acute MI (AMI) (8) using cTnT or cTnI and low decision limits has led to a shift in diagnoses among patients with NSTEMACS from unstable angina to (NSTEMI) AMI, with an increase of 20–30% in the number of AMI diagnoses (9).

## THE PROGNOSTIC CHALLENGE

As described, the accurate identification of patients at high risk of recurrent clinical events is an important and often challenging clinical objective. Cardiac troponin has proven very valuable in this regard. Because the predictive ability of individual biomarkers may differ considerably among different clinical end points, it is worthwhile to consider the relationship between troponin and the risk of specific cardiovascular events separately.

### *Death and MI*

Numerous studies have been published showing, almost without exception, that troponin elevation is predictive of the risk of death/new or recurrent MI, in both the short and long term (Table 2). In a meta-analysis (26), the relative odds of death or MI at 30 d was 4.93 (95% confidence interval [CI]: 3.77–6.45) for NSTEMACS patients with positive troponin. This strong risk relationship is also present when the individual elements of this composite end point are considered.

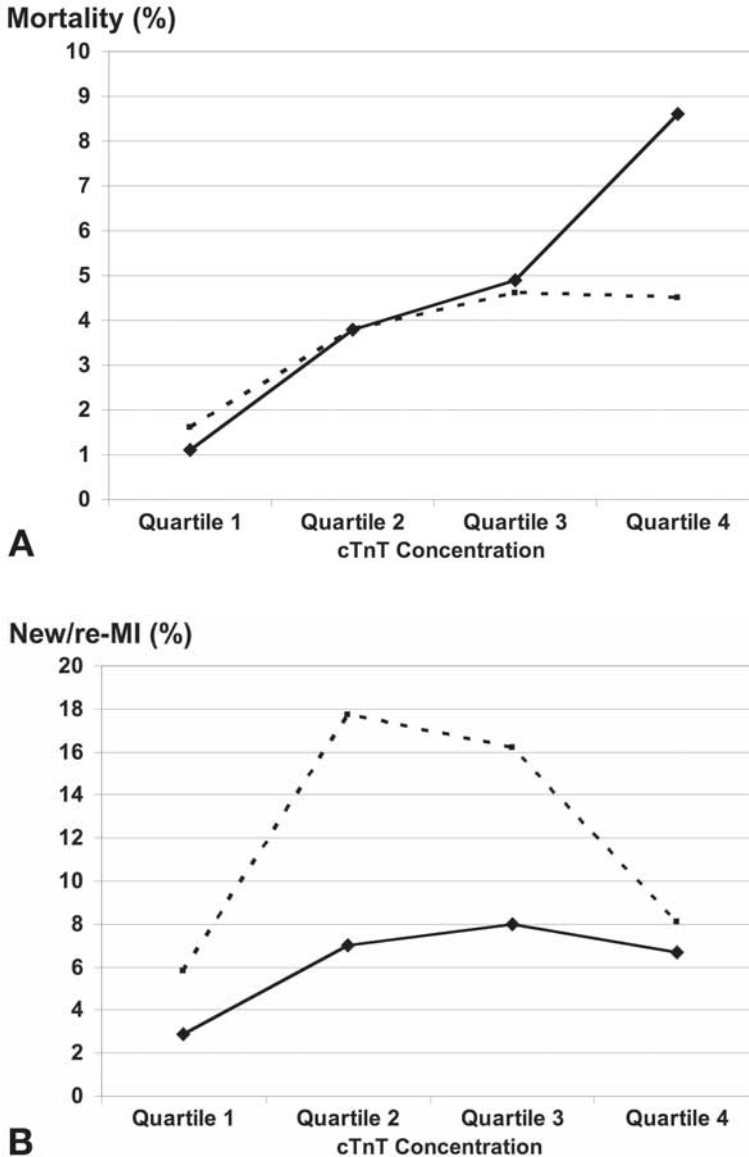
Patients with elevation of troponin T or I are at significantly higher risk of mortality, in both the short and long term (Table 2). In a meta-analysis of data from clinical trials, the relative odds of death for patients with elevated cTnT and cTnI were 3.0 (95% CI: 1.6–5.5) and 2.6 (95% CI: 1.8–3.6), respectively (27). In a separate analysis of observational cohort studies, the corresponding odds ratios (ORs) were 5.1 (95% CI: 3.2–8.4) and 8.5 (95% CI: 3.5–21.1) (27). Furthermore, the relationship between troponin and the risk of death shows a gradual graded relationship (Fig. 3A).

Table 2  
Event Rates by Troponin Status in Studies (NSTEACS or NSTEMI Chest Pain) Enrolling More Than 300 Patients

Study	Assay	Cutoff ( $\mu\text{g/L}$ )	Follow-up	Death/AMI		Death		AMI	
				Negative (%)	Positive (%)	Negative (%)	Positive (%)	Negative (%)	Positive (%)
Randomized clinical trials									
FRISC (10)	cTnT, Enzymun	0.06	5 mo	4	12	0	6	—	—
TIMI IIIB (11)	cTnI, Stratus II	0.4	42 d	—	—	1.0	3.7	—	—
TRIM (12)	cTnT, Enzymun	0.1	30 d	4	11	0.4	3.2	4	9
	cTnI, Opus	2.0	30 d	5	11	0.7	3.2	5	8
FRISCII (13,14) <sup>a</sup>	cTnT, Elecsys	0.01	1 yr	6.8	16.5	1.6	4.3	5.5	14.0
	cTnT, Elecsys	0.03	1 yr	8.9	16.9	2.6	4.4	—	—
	cTnI, AxSym	1.0	1 yr	9.3	16.9	2.8	4.3	—	—
	cTnI, Access	0.03	1 yr	6.3	16.5	1.1	4.5	—	—
GUSTO-IV (15)	cTnT, Elecsys	0.01	30 d	3.4	10.2	1.1	4.9	2.5	6.5
TIMI-11B (16)	cTnI, Dimension	0.1	43 d	3.9	17.2	3.4	8.3	2.2	13.3
TACTICS (17) <sup>a</sup>	cTnI, ACS	0.1	6 mo	3.8	12.6	1.6	4.3	—	—
PRISM (18) <sup>b</sup>	cTnI, AxSym	1.0	30 d	4.9	13.0	2.3	6.2	2.6	6.8
	cTnT, Elecsys	0.1	30 d	4.7	13.7	1.8	7.3	—	—
PARAGON-B (19)	cTnT, Elecsys	0.1	6 mo	10.9	18.1	3.3	7.4	9.7	13.6
Cohort observational studies									
Stubbs et al. (20)	cTnT, Enzymun	0.2	3 yr	17	29	12	19	—	—
FAST (21)	cTnT, Enzymun	0.1	30 d	1.4	6.8	0	4.3	—	—
Hamm et al. (22)	cTnT strip test	—	30 d	1.1	22.0	0.6	13.0	—	—
	cTnI strip test (Spectral)	—	30 d	0.3	18.7	0.2	11.1	—	—
Aviles et al. (23)	cTnT, ACS:180	0.5	2 yr	—	—	8	20	—	—
deFilippi et al. (24)	cTnT, enzymun	0.1	1 yr	—	—	0.3	3	0.8	6
Kontos et al. (25)	cTnI	—	30 d	—	—	0.8	5.8	—	—

<sup>a</sup>Noninvasive cohort.

<sup>b</sup>Heparin cohort.



**Fig. 3.** (A) One-year and 30-d mortality in relation to quartiles of cTnT in FRISC-II study (dashed line) (13) and GUSTO-IV study (solid line) (15), respectively. (B) Rate of MI at 1 yr and 30 d in relation to quartiles of cTnT in FRISC-II study (dotted line) (13) and GUSTO-IV study (solid line) (15), respectively.

Patients with elevated troponin also have an increased risk of recurrent AMI (Table 2). However, in contrast to the graded increase in risk of death in relation to troponin concentration, there seems to be a nonmonotonic relationship for the risk of a new MI (Fig. 3B). Indeed, the risk of suffering a new AMI seems to be higher in those with only minor elevations compared with those with major elevations of troponin (who may have completed the infarction in the territory at risk). Thus, a high analytic precision of the troponin assay at the low end of the detectable range is an attribute that is especially important for the prediction of AMI.

### *Other Cardiac Events*

There is a strong association between elevated troponin results and the revascularization rate in most studies. In most studies, the indications for revascularization were not specified, and in some the troponin results were available to the clinicians, a factor that might have directly influenced the decision to revascularize a patient. Information regarding an association between troponin and the risk of rehospitalization is scarce. One small study has indicated that the risk of rehospitalization for cardiac reasons is higher in cTnT-positive compared with cTnT-negative patients (28). Data regarding the risk of developing congestive heart failure (CHF) in relation to troponin level in NSTEMI/ACS patients are also very limited; one study has suggested an increased rate of admissions for CHF in troponin-positive patients (24).

#### **COMBINATION OF TROPONIN WITH OTHER MARKERS**

The value of adding another biomarker of necrosis to troponin is controversial. Most studies, although not all, have shown no additive prognostic value of CK-MB to that of troponin. Some studies have indicated that myoglobin might add early diagnostic and prognostic information. However, some argue that the added prognostic information, if any, is limited and cannot justify the increased costs of routinely measuring more than one marker of necrosis.

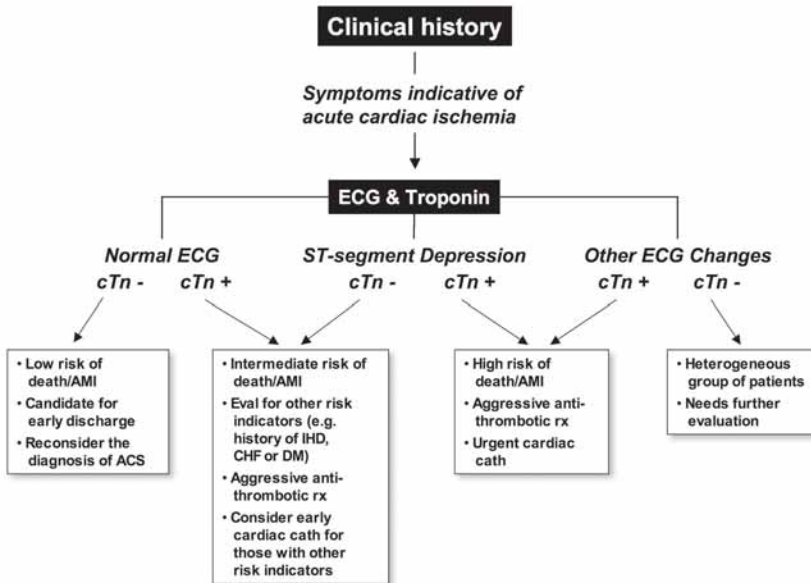
New biochemical markers have been introduced and evaluated, such as markers of inflammation (e.g., C-reactive protein) and of cardiac performance (e.g., B-type natriuretic peptide). Several of them seem to add important prognostic information beyond that of the clinical history, ECG, and troponin level. These markers and their role in a true multi-marker strategy for risk assessment are dealt with in depth in Chapter 31.

### *An Integrated Approach to Risk Assessment*

In addition to measurements of troponin, the clinical history and the standard 12-lead ECG constitute the basis for accurate assessment of risk. A thoughtful interpretation of the patient's symptoms is essential for appropriate diagnosis and risk stratification. Previous manifestations of ischemic heart disease and comorbidities, such as CHF, diabetes mellitus, or renal dysfunction, are associated with an increased risk of new cardiac events independent of troponin. The standard 12-lead ECG is an indispensable prognostic tool: it is inexpensive, rapid, and widely available. In patients with a clinical suspicion of an ACS, a perfectly normal ECG on admission is associated with a low risk of future cardiac events, and in combination with a normal troponin result, the associated risk is very low (21). Although a diagnosis of unstable angina remains possible, the combination of a normal ECG and no troponin elevation should lead to reconsideration of the diagnosis of an ACS. ST-segment depression is associated with a high risk of new events, especially when combined with an elevated troponin (10). Furthermore, the more severe the ST-segment depression (in depth and/or in extension), the higher the risk (29). Patients with other abnormal ECG changes constitute a more inhomogeneous group but have a higher risk than patients with a normal ECG (29).

Thus, none of these factors should be considered in isolation. Instead, to make a proper risk assessment in the individual patient, one needs to consider these factors simultaneously and integrate all the available information. Figure 4 presents a simple algorithm for risk stratification based on these factors. An alternative is to use one of the scoring systems that has been developed based on the clinical history, ECG changes, and markers of myocardial





**Fig. 4.** Simple algorithm for risk prediction and treatment using clinical history, ECG, and troponin measurements in patients with clinical suspicion of NSTEMI/ACS. IHD, ischemic heart disease; DM, diabetes mellitus.

damage. The Thrombolysis in Myocardial Infarction (TIMI) risk score for unstable angina/NSTEMI is the best known and most widely used system (30).

### *Interpretation of Clinical Studies of Troponin*

When interpreting study results on the prognostic value of risk indicators or markers, the population in whom the study was performed must be considered. Patients enrolled in randomized clinical trials are often highly selected and with (more or less) established ACS, whereas most observational studies have less restricted inclusion criteria. Generally, the relative risk or OR for a clinical event associated with a positive marker is higher in the observational studies. Nevertheless, the prognostic associations observed with cardiac troponin are evident in populations from both clinical trials of ACS and consecutive series of patients with chest pain enrolled in emergency settings.

## THE THERAPEUTIC CHALLENGE

A variety of therapeutic options are available in the management of patients with NSTEMI/ACS. However, some of these are rather costly and have potential serious side effects. Therefore, identification of those who benefit most from a particular therapy has become a central tenet in the management of patients with NSTEMI/ACS. The beneficial effects of antithrombotic treatment with low-molecular-weight heparins, antiplatelet therapy with glycoprotein IIb/IIIa receptor inhibitors, and an invasive approach with early revascularization have been shown to be greatest in patients with an elevated level of troponin (Table 3). Hence, in recent guidelines troponin testing has been incorporated in treatment algorithms (3) in conjunction with evaluation for ST-segment depression in the 12-lead ECG or during ST-monitoring as another useful sign for identifying patients who benefit from more aggressive antithrombotic (36) and invasive treatment (29). In the

Table 3  
Treatment Effect Regarding Death/MI by Troponin Status

Therapy	Troponin negative			Troponin positive		
	Active (%)	Control (%)	p value	Active (%)	Control (%)	p value
Low-molecular-weight heparin						
FRISC (40 d) (31)	5.7	4.7	NS	7.4	14.2	<0.01
FRISC-II (3 m) (32)	6.1	6.4	NS	6.6	9.3	0.07
TIMI 11-B (14 d) (16)	4	0	NS	10.0	17.0	NS
Glycoprotein IIb/IIIa receptor inhibitors						
CAPTURE (6 m) (33)	9.4	7.5	NS	9.5	23.9	<0.01
PRISM (30 d) (18)	5.7	4.9	NS	4.3	13.0	<0.001
PARAGON-B (30 d) (19)	9.7	9.4	NS	11.1	18.8	<0.05
GUSTO-IV (30 d) (34)	6.1	5.4	NS	10.0	10.0	NS
Early invasive strategy						
TACTICS (6 m) (17)	4.4	3.8	NS	8.5	12.6	<0.05
FRISC-II (12 m) (35)	7.4	8.5	NS	11.6	16.6	<0.01

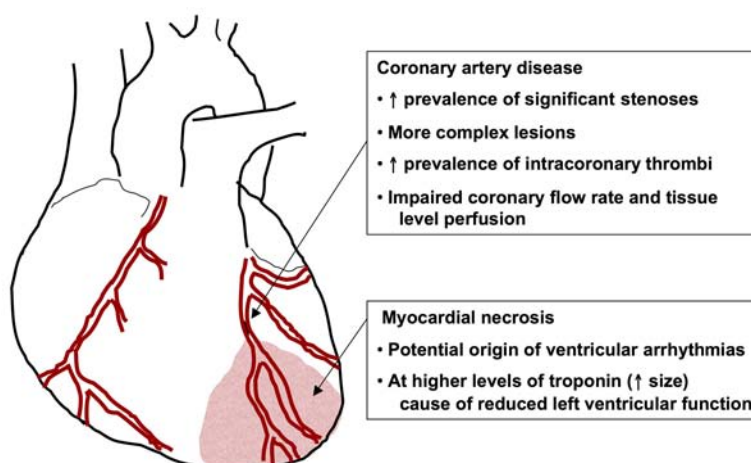
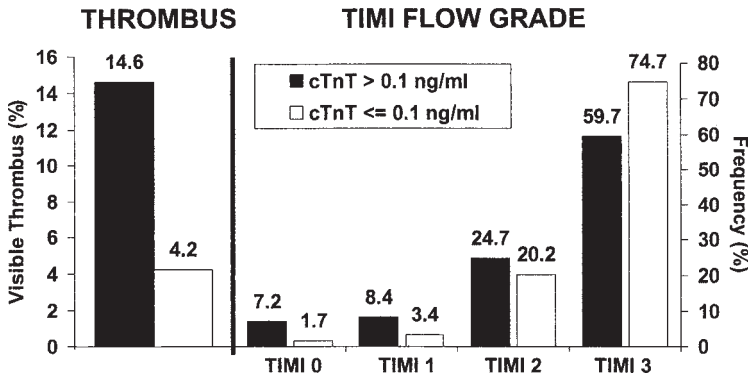


Fig. 5. Summary of suggested mechanisms behind prognostic value of troponin in NSTEMACS.

FRISC-II trial, the beneficial effect of an invasive approach was almost confined to the one-third of patients who had both elevated troponin and ST-segment depression, and in this subgroup the invasive strategy nearly halved the risk of death/MI, from 22.1 to 13.2%, at 12 mo (35).

### MECHANISMS UNDERLYING PROGNOSTIC RELATIONSHIP OF TROPONIN IN ACS

The increased risk of new cardiac events associated with elevated troponin in patients with a clinical suspicion of NSTEMACS can be attributed to clinical and pathological features associated with abnormal troponin results including underlying severe coronary stenosis; culprit lesion thrombosis; downstream embolization with microinfarction; and in some patients, total coronary occlusion, a large MI, and reduced left ventricular function (Fig. 5). The subgroup of patients without troponin elevation consists partly of those



**Fig. 6.** Increased thrombus burden and impaired flow (TIMI flow grade <3) in patients with elevated cTnT. (Reproduced from ref. 38 with permission.)

without significant atherosclerotic coronary artery disease (CAD), whose symptoms often have noncardiac causes, and partly of patients with CAD, whose symptoms might be caused by an increase in oxygen demand or a decrease in oxygen supply unrelated to coronary thrombosis. The probability of significant coronary stenosis rises considerably at any detectable level of troponin elevation, and the likelihood of an unstable plaque with thrombus and downstream microembolization, impairment of coronary flow, and tissue-level perfusion increases (Fig. 6) (13,37). The latter mechanisms also explain why treatment with antithrombin or platelet inhibitors is protective mainly in patients with elevated troponin. Low-level increases in troponin are usually not associated with a completed infarction in the territory at risk but reflect unstable plaque and thrombus in the culprit vessel that confer a higher risk of causing further myocardial damage. In patients with higher elevations of troponin, a greater proportion will have a persistent occlusion of the culprit coronary vessel and may have completed the infarction in the jeopardized territory, leading to lower risk of new myocardial injury in the same territory. However, the larger infarct size is associated with reduced left ventricular function and, thus, higher mortality (13).

## PRACTICAL ISSUES

### *Troponin I or T?*

In the past, there has been controversy over which biomarker is preferable, troponin I or T. However, there is no convincing scientific evidence that either of these two markers is superior to the other. Hence, it is more important to focus on the analytic and clinical performance of the assay, rather than which troponin is being tested. Owing to patent restrictions, only one commercial assay for cTnT exists, whereas there are many different assays for cTnI on the market. These assays and their newer generations differ from one another in several aspects, such as analytic sensitivity, imprecision, and sensitivity to interfering antibodies. Therefore, each assay must be evaluated separately with respect to both analytic and clinical performance. It is important for clinicians to be familiar with the properties, especially the imprecision of the assay at the low end of the reported range, of the particular assay used at the hospital where they practice. In addition, clinicians need to be familiar with the published evidence supporting the specific decision limits reported by their laboratory for that assay.

### *Timing of Troponin Measurement*

Although many patients with NSTEMI/ACS with myocardial damage will have abnormal troponin results at the time of presentation, a significant proportion will develop troponin elevation during the next few hours. After the first 6–9 h, new troponin elevations are seldom found, except when associated with new ischemic symptoms. By taking a careful history and performing a thorough clinical examination, obtaining an ECG, and measuring troponin on admission, the clinician can immediately identify many high-risk patients and initiate appropriate treatment. With repeated measurement of troponin at 6–9 h after presentation, most of the remaining patients can be properly assessed. Additional testing of troponin 12–24 h after presentation should be considered in patients for whom there is a high clinical suspicion of ACS. Several studies have found such rapid triage protocols to be effective and safe (39,40). Point-of-care assays may reduce the time to availability of troponin results.

### *Decision Limits for Risk Stratification*

#### **ESC/ACC RECOMMENDATION**

The joint ESC/ACC committee on redefinition of MI proposed that the 99th percentile value of troponin in a reference control population be used as the decision level for the diagnosis of AMI on the condition that the imprecision (expressed as the coefficient of variation [CV]) of the particular assay at the 99th percentile level is below 10% (8). If the assay does not meet this latter criterion, the level of 10% CV was recommended as the decision limit. To this point, very few commercial troponin assays have been able to meet this stringent requirement regarding precision. Furthermore, the committee recommended the use of one and the same decision limit for the diagnosis of MI and risk stratification. The lower detection limits, 99th percentile, and 10% CV levels for the most commonly used troponin assays have been described elsewhere in this book.

#### **LOW-LEVEL ELEVATION**

*Low-level* elevation has been applied as a descriptive term referring to quantitatively minor increases in the concentration of troponin but has not been defined in relation to specific analytic criteria (e.g., 99th percentile, or 10% CV). Thus, the term is used quite variably by clinicians and in the published literature. Since introduction of the ESC/ACC definition, many clinicians have questioned the significance of concentrations of troponin above this decision limit but below manufacturer-recommended cut points for MI, which are still often based on comparison to CK-MB. Consistent data from studies that include both clinical trials and unselected patients with suspected ACS demonstrate that levels of troponin in this range are independently associated with a higher risk of recurrent cardiovascular events (Table 2).

Emerging data also suggest that in patients with a *high clinical probability* of ACS increases in troponin above the lower limit of detection (LLD) but *below* the ESC/ACC decision limit are also associated with greater risk of complications. For example, in the TACTICS-TIMI 18 study, patients with a baseline cTnI >99th percentile (0.1 ng/mL) but below the ESC/ACC decision limit (0.4 ng/mL, 10% CV) were at more than threefold higher risk of death or MI ( $p < 0.001$ ) (17). Ten percent of patients fell into this range of low-level elevation and would be “misclassified” as low risk if the decision limit of 0.4 ng/mL were applied. This observation is supported by studies with cTnT, and using other assays for cTnI (14,41) in populations enrolled in clinical trials, as well as in unselected

patients with suspected ACS (25). Specifically, in a cohort with possible ACS stratified according to peak cTnI—negative (<LLD), low ( $\oplus$ LLD to <ESC/ACC decision limit), intermediate (ESC/ACC decision limit to <manufacturer's suggested MI limit), and high ( $\oplus$ suggested MI limit)—6-mo mortality showed a graded rise across categories of cTnI (hazard ratios of 2.5 [95% CI: 1.4–4.4] for low, 3.9 [95% CI: 2.3–6.8] for intermediate, and 6.1 [95% CI: 4.2–8.7] for high cTnI) (25).

Despite these findings in predominantly selected patients with ACS, the ESC/ACC decision limit, set at the 99th percentile in conjunction with acceptable precision, is likely to be optimal in most settings because it will minimize analytic false positives. Nevertheless, clinicians should recognize that in patients with a high (pretest) probability of ACS a troponin result above the LLD (with present assays) identifies those at higher risk of adverse outcomes. Thus, for patients with a compelling history suggesting ACS who are found to have low-level elevation of troponin, the result should be recognized as a marker of increased risk and appropriate therapeutic actions (e.g., early invasive management) considered. In patients with a low or uncertain probability of ACS, troponin results in this range should prompt consideration of alternative causes and repeat testing employed to reduce the probability of an analytic false positive.

## CONCLUSION

Applied in conjunction with the clinical history, physical examination, and interpretation of the ECG, cardiac troponin is a cornerstone of the prognostic assessment of patients presenting with possible ACS. Cardiac troponin offers clinical sensitivity and specificity that is superior to other available biomarkers of myocardial necrosis and, thus, is the preferred biomarker for diagnosis and risk assessment in this setting. In addition, to provide insight into patients' risk of recurrent ischemic events, measurement of troponin is valuable in guiding the targeting of more aggressive therapy to those who are likely to benefit most. It is essential for the clinician to be familiar with the evidence-based decision limits for risk assessment established for the assays used in their practice.

## REFERENCES

1. Granger CB, Goldberg RJ, Dabbous O, et al. Predictors of hospital mortality in the global registry of acute coronary events. *Arch Intern Med* 2003;163:2345–2353.
2. Goldberg RJ, Currie K, White K, et al. Six-month outcomes in a multinational registry of patients hospitalized with an acute coronary syndrome (the Global Registry of Acute Coronary Events [GRACE]). *Am J Cardiol* 2004;93:288–293.
3. Bertrand ME, Simoons ML, Fox KA, et al. Management of acute coronary syndromes in patients presenting without persistent ST-segment elevation. *Eur Heart J* 2002;23:1809–1840.
4. Pettersson T, Ohlsson O, Tryding N. Increased CKMB (mass concentration) in patients without traditional evidence of acute myocardial infarction: a risk indicator of coronary death. *Eur Heart J* 1992;13:1387–1392.
5. Ravkilde J, Horder M, Gerhardt W, et al. Diagnostic performance and prognostic value of serum troponin T in suspected acute myocardial infarction. *Scand J Clin Lab Invest* 1993;53:677–685.
6. Hamm CW, Ravkilde J, Gerhardt W, et al. The prognostic value of serum troponin T in unstable angina. *N Engl J Med* 1992;327:146–150.
7. Collinson PO, Stubbs PJ. Are troponins confusing? *Heart* 2003;89:1285–1287.
8. Alpert JS, Thygesen K, Antman E, Bassand JP. Myocardial infarction redefined—a consensus document of The Joint European Society of Cardiology/American College of Cardiology Committee for the redefinition of myocardial infarction. *J Am Coll Cardiol* 2000;36:959–969.
9. Koukkunen H, Penttila K, Kempainen A, et al. Differences in the diagnosis of myocardial infarction by troponin T compared with clinical and epidemiologic criteria. *Am J Cardiol* 2001;88:727–731.

10. Lindahl B, Venge P, Wallentin L. Relation between troponin T and the risk of subsequent cardiac events in unstable coronary artery disease. *Circulation* 1996;93:1651–1657.
11. Antman EM, Tanasijevic MJ, Thompson B, et al. Cardiac-specific troponin I levels to predict the risk of mortality in patients with acute coronary syndromes. *N Engl J Med* 1996;335:1342–1349.
12. Lüscher MS, Thygesen K, Ravkilde J, et al. Applicability of cardiac troponin T and I for early risk stratification in unstable coronary artery disease. *Circulation* 1997;96:2578–2585.
13. Lindahl B, Diderholm E, Lagerqvist B, Venge P, Wallentin L. Mechanisms behind the prognostic value of troponin T in unstable coronary artery disease: a FRISC II substudy. *J Am Coll Cardiol* 2001;38:979–986.
14. Venge P, Lagerqvist B, Diderholm E, Lindahl B, Wallentin L. Clinical performance of three cardiac troponin assays in patients with unstable coronary artery disease (a FRISC II substudy). *Am J Cardiol* 2002;89:1035–1041.
15. James SK, Armstrong P, Barnathan E, et al. Troponin and C-reactive protein have different relations to subsequent mortality and myocardial infarction after acute coronary syndrome: a GUSTO-IV substudy. *J Am Coll Cardiol* 2003;41:916–924.
16. Morrow DA, Antman EM, Tanasijevic M, et al. Cardiac troponin I for stratification of early outcomes and the efficacy of enoxaparin in unstable angina: a TIMI-11B substudy. *J Am Coll Cardiol* 2000;36:1812–1817.
17. Morrow DA, Cannon CP, Rifai N, et al. Ability of minor elevations of troponins I and T to predict benefit from an early invasive strategy in patients with unstable angina and non-ST elevation myocardial infarction: results from a randomized trial. *JAMA* 2001;286:2405–2412.
18. Heeschen C, Hamm CW, Goldmann B, Deu A, Langenbrink L, White HD. Troponin concentrations for stratification of patients with acute coronary syndromes in relation to therapeutic efficacy of tirofiban. PRISM Study Investigators. Platelet Receptor Inhibition in Ischemic Syndrome Management. *Lancet* 1999;354:1757–1762.
19. Kaul P, Newby LK, Fu Y, et al. Troponin T and quantitative ST-segment depression offer complementary prognostic information in the risk stratification of acute coronary syndrome patients. *J Am Coll Cardiol* 2003;41:371–380.
20. Stubbs P, Cllinson P, Moseley D, Greenwood T, Noble M. Prospective study of the role of cardiac troponin T in patients admitted with unstable angina. *Br Med J* 1996;313:262–264.
21. Jernberg T, Lindahl B. A combination of troponin T and 12-lead electrocardiography: a valuable tool for early prediction of long-term mortality in patients with chest pain without ST-segment elevation. *Am Heart J* 2002;144:804–810.
22. Hamm CW, Goldmann BU, Heeschen C, Kreymann G, Berger J, Meinertz T. Emergency room triage of patients with acute chest pain by means of rapid testing for cardiac troponin T or troponin I. *N Engl J Med* 1997;337:1648–1653.
23. Aviles RJ, Wright RS, Aviles JM, et al. Long-term prognosis of patients with clinical unstable angina pectoris without elevation of creatine kinase but with elevation of cardiac troponin I levels. *Am J Cardiol* 2002;90:875–878.
24. deFilippi CR, Tocchi M, Parmar RJ, et al. Cardiac troponin T in chest pain unit patients without ischemic electrocardiographic changes: angiographic correlates and long-term clinical outcomes. *J Am Coll Cardiol* 2000;35:1827–1834.
25. Kontos MC, Shah R, Fritz LM, et al. Implication of different cardiac troponin I levels for clinical outcomes and prognosis of acute chest pain patients. *J Am Coll Cardiol* 2004;43:958–965.
26. Ottani F, Galvani M, Nicolini FA, et al. Elevated cardiac troponin levels predict the risk of adverse outcome in patients with acute coronary syndromes. *Am Heart J* 2000;140:917–927.
27. Heidenreich PA, Alloggiamento T, Melsop K, McDonald KM, Go AS, Hlatky MA. The prognostic value of troponin in patients with non-ST elevation acute coronary syndromes: a meta-analysis. *J Am Coll Cardiol* 2001;38:478–485.
28. Mockel M, Stork T, Heller G Jr, et al. Troponin T in patients with low grade or atypical angina. Identification of a high risk group for short- and long-term cardiovascular events. *Eur Heart J* 1998;19:1802–1807.
29. Holmvang L, Clemmensen P, Lindahl B, et al. Quantitative analysis of the admission electrocardiogram identifies patients with unstable coronary artery disease who benefit the most from early invasive treatment. *J Am Coll Cardiol* 2003;41:905–915.
30. Antman EM, Cohen M, Bernink PJ, et al. The TIMI risk score for unstable angina/non-ST elevation MI: a method for prognostication and therapeutic decision making. *JAMA* 2000;284:835–842.
31. Lindahl B, Venge P, Wallentin L. Troponin T identifies patients with unstable coronary artery disease who benefit from long term antithrombotic protection. *J Am Coll Cardiol* 1997;29:43–48.

32. FRagmin and Fast Revascularisation during InStability in Coronary Artery Disease Investigators. Long-term low-molecular-mass heparin in unstable coronary-artery disease: FRISC II prospective randomised multicentre study. *Lancet* 1999;354:701–707.
33. Hamm CW, Heeschen C, Goldmann B, et al. Benefit of abciximab in patients with refractory unstable angina in relation to serum troponin T levels. c7E3 Fab Antiplatelet Therapy in Unstable Refractory Angina (CAPTURE) Study Investigators. *N Engl J Med* 1999;340:1623–1629.
34. Simoons ML. Effect of glycoprotein IIb/IIIa receptor blocker abciximab on outcome in patients with acute coronary syndromes without early coronary revascularisation: the GUSTO IV-ACS randomised trial. *Lancet* 2001;357:1915–1924.
35. Diderholm E, Andren B, Frostfeldt G, et al. The prognostic and therapeutic implications of increased troponin T levels and ST depression in unstable coronary artery disease: the FRISC II invasive troponin T electrocardiogram substudy. *Am Heart J* 2002;143:760–767.
36. Jernberg T, Abrahamsson P, Lindahl B, Johanson P, Wallentin L, Dellborg M. Continuous multilead ST-monitoring identifies patients with unstable coronary artery disease who benefit from extended anti-thrombotic treatment. *Eur Heart J* 2002;23:1093–1101.
37. Wong GC, Morrow DA, Murphy S, et al. Elevations in troponin T and I are associated with abnormal tissue level perfusion: a TACTICS-TIMI 18 substudy. Treat Angina with Aggrastat and Determine Cost of Therapy with an Invasive or Conservative Strategy-Thrombolysis in Myocardial Infarction. *Circulation* 2002;106:202–207.
38. Morrow DA. Troponins in patients with acute coronary syndromes: biologic, diagnostic, and therapeutic implications. *Cardiovasc Toxicol* 2001;1:105–110.
39. Lateef F, Storrow AB, Malone K, Liu T, Gibler BW. Comparison of a 6-hour and 9-hour protocol for evaluation of moderate-to-low risk chest pain patients in an emergency department diagnostic unit. *Singapore Med J* 2001;42:52–56.
40. Herren KR, Mackway-Jones K, Richards CR, Seneviratne CJ, France MW, Cotter L. Is it possible to exclude a diagnosis of myocardial damage within six hours of admission to an emergency department? Diagnostic cohort study. *BMJ* 2001;323:372–375.
41. James S, Armstrong P, Califf R, et al. Troponin T levels and risk of 30-day outcomes in patients with the acute coronary syndrome: prospective verification in the GUSTO-IV trial. *Am J Med* 2003;115:178–184.

# 6

---

## Biomarkers of Necrosis for Risk Assessment and Management of ST-Elevation Myocardial Infarction

---

*Evangelos Giannitsis, MD  
and Hugo A. Katus, MD*

### CONTENTS

INTRODUCTION  
CONFIRMATION OF DIAGNOSIS OF ACUTE MYOCARDIAL INFARCTION  
MONITORING EFFICIENCY OF REPERFUSION THERAPY  
RISK STRATIFICATION  
ESTIMATION OF INFARCT SIZE  
CONCLUSION  
REFERENCES

---

### SUMMARY

The diagnosis and immediate initiation of reperfusion therapy in patients with acute ST-elevation myocardial infarction (STEMI) are based on results of the standard 12-lead electrocardiogram. Because the appearance of cardiac markers of myocardial injury in the blood is delayed relative to the onset of symptom, cardiac markers are neither helpful for early diagnosis nor should their results be awaited before initiation of reperfusion therapy. Nevertheless, there are four important reasons to measure cardiac markers of necrosis in patients with STEMI: (1) confirmation of diagnosis, (2) monitoring of efficiency of reperfusion, (3) assessment of risk, and (4) infarct sizing.

**Key Words:** Troponin; myocardial infarction; prognosis; diagnosis.

### INTRODUCTION

In patients with acute ST-elevation myocardial infarction (STEMI), the diagnosis and immediate initiation of reperfusion therapy are based on results of the standard 12-lead electrocardiogram (ECG) (1). Owing to the fact that cardiac markers appear in blood a substantial time after the onset of symptoms, cardiac markers neither are helpful for early diagnosis nor should their results be awaited before initiation of recanalization therapy.

From: *Contemporary Cardiology:  
Cardiovascular Biomarkers: Pathophysiology and Disease Management*  
Edited by: David A. Morrow © Humana Press Inc., Totowa, NJ



This relates also to the so-called early markers such as myoglobin, fatty acid-binding protein (FABP) or creatine kinase (CK)-MB subforms. In clinical studies, patients with STEMI presented with positive results for FABP, CK, or troponin in 72, 54, and 51%, respectively (2). Such a low sensitivity of cardiac markers on admission precludes the integration of marker results into initial treatment algorithms of patients with STEMI. This limitation pertains to all diagnostic biomarkers studied in STEMI to date. Nevertheless, there are four important reasons to measure cardiac markers of necrosis in patients with STEMI: (1) confirmation of diagnosis, (2) monitoring of efficiency of reperfusion, (3) assessment of risk, and (4) infarct sizing. Each of these reasons is discussed in this chapter.

## CONFIRMATION OF DIAGNOSIS OF ACUTE MYOCARDIAL INFARCTION

According to the World Health Organization, a definite diagnosis of acute myocardial infarction (AMI) is made in the presence of unequivocal ECG changes (development of abnormal, persistent Q waves or QS waves and evolving injury current for >24 h) and/or unequivocal biomarker changes (serial changes related to the onset of symptoms and the respective marker) (3). More recently, an ESC/AHA task force has recommended the use of troponins as the preferred cardiac marker and stated that any significant elevation of a cardiospecific troponin in the setting of myocardial ischemia establishes the diagnosis of AMI (4).

Although symptoms and typical ECG changes may suffice for diagnostic classification of STEMI patients, release of strictly intracellular and cardiospecific molecules and their detection in blood are the most convincing indicators of severe myocardial damage. Some patients with initial ST-elevation will not progress to QRS changes on ECG but still reveal elevated such biomarkers of necrosis in the blood. Thus, confirmation of the diagnosis of AMI by cardiac markers is recommended even in the setting of symptoms and ST-elevation on admission.

Because cardiac troponins provide superior cardiospecificity to other available markers of necrosis such as CK-MB and myoglobin, troponin T or I should be used to confirm the presence of myocardial injury in the setting of STEMI (5). When troponins are not available, CK-MB may be used with similar diagnostic efficiency in this highly selected clinical subgroup (4). Owing to the short half-life of troponin in the circulation (~90 min), the blood levels of troponin on d 3 or 4 reflect degradation of the contractile machinery, which is a hallmark of irreversible cell injury (6). Thus, in the absence of ongoing ischemia, a troponin elevation on d 3 or 4 after the onset of symptoms may be taken as definite proof of irreversible myocardial injury.

## MONITORING EFFICIENCY OF REPERFUSION THERAPY

### *Thrombolytic Therapy*

Early and complete patency of infarct-related coronary arteries (IRAs) is the central therapeutic goal in STEMI. Compared with direct percutaneous coronary intervention (PCI), fibrinolytic therapy is associated with significantly lower rates of complete reperfusion (Thrombolysis in Myocardial Infarction [TIMI] grade 3 flow) of the IRA and does not allow visualization of reperfusion success. Among many methods used to assess the success of reperfusion, resolution of ST-elevation early after reperfusion therapy is the most widely applied noninvasive method (7,8). Cardiac markers can complement the ECG

in assessing the success or failure of fibrinolytic reperfusion. Specifically, patients with AMI who develop a patent IRA will release considerably more proteins of necrosis into the circulation (“washout phenomenon”) when compared with patients who have persistent occlusion (6,9).

Several biomarkers and numerous algorithms have been proposed for the prediction of reperfusion (10). Almost all algorithms require at least two blood samples, one obtained on initiation of fibrinolytic therapy and a second 60 or 90 min thereafter (9,11–14). Shorter times to peak values, steeper upslopes, and/or greater relative increases in necrosis markers have all been found to be associated with successful reperfusion (10). Cardiac troponins have at least some theoretical advantages over the other soluble markers such as myoglobin or CK-MB, including superior cardiac specificity, and the largest tissue-to-circulation gradient generating an excellent signal (10). As is the case for ST-segment resolution, monitoring using biochemical marker strategies reflects not only epicardial flow but also microvascular and tissue-level reperfusion.

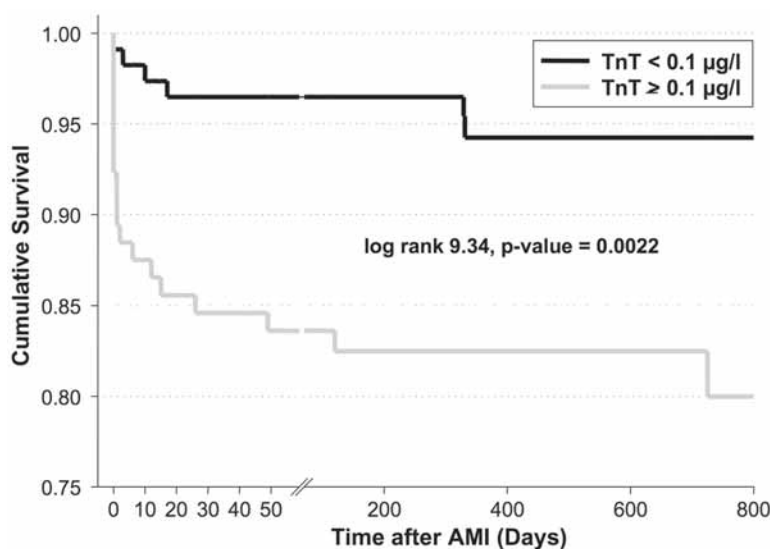
### *Primary PCI*

Usually the success of reperfusion after primary PCI is easily visualized on coronary angiography. However, a substantial proportion of patients deemed to have successful reperfusion have persistent compromise of myocardial blood flow owing to microvascular obstruction (15,16). Several methods may be used for identification of microvascular obstruction, including myocardial contrast echocardiography, ST-segment resolution, magnetic resonance tomography (MRT), intracoronary Doppler flow measurement, and coronary angiography using the myocardial blush grade. The utilization of cardiac markers for this purpose is relatively novel and the rationale for their use is largely based on findings from fibrinolytic trials.

Successful reperfusion of the IRA is associated with a rise in blood concentrations (“washout”) that is more brisk after mechanical reperfusion than after fibrinolytic therapy (17). Because this washout phenomenon reflects both reperfusion at the myocardial tissue level and epicardial blood flow, it is tempting to speculate that marker kinetics might be helpful for assessment of microvascular reperfusion.

Accordingly, Frostfeldt et al. (18) found a significantly higher relative increase in myoglobin concentration and a trend toward higher rates of complete resolution (>70%) of ST-segments in patients who tested negative for cardiac troponin T (cTnT) on admission, suggesting normal microvascular reperfusion. Lehrke et al. (19) demonstrated that abciximab administered during primary PCI improved the early washout of cTnT in patients who tested positive for troponin on admission, in patients with diabetes, and in older patients, suggesting a higher propensity for impaired microvascular perfusion in some subsets of patients. A close association between baseline elevation in troponin and abnormal tissue-level reperfusion was also shown in patients with an acute coronary syndrome (ACS) without ST-elevation (20). Thus, there is increasing evidence that elevations in troponin resulting from embolization of platelet microaggregates may not only be a surrogate for the presence of unstable plaque but also for microvascular obstruction independent of recanalization of the occluded IRA.

Kurowski et al. (21) reported higher mortality rates for patients with elevated cTnT levels on admission, despite restoration of TIMI 3 grade flow (Fig. 1). Troponin T remained independently predictive even after adjustment for longer time delays from the onset of symptoms to admission and for infarct location. These findings may relate to the adverse



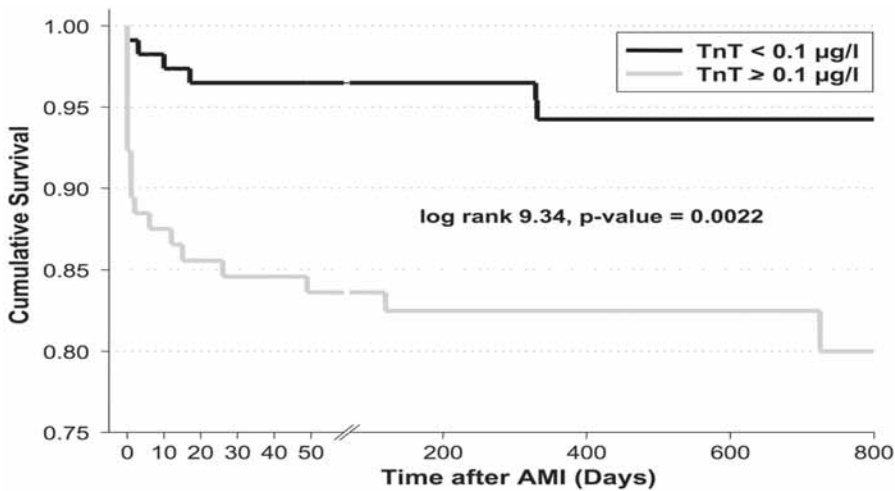
**Fig. 1.** Survival plot showing higher short- and long-term mortality (log rank  $p=0.0022$ ) associated with elevated troponin T on admission despite subsequent successful primary PCI. (Adapted from ref. 21.)

prognostic impact that has been attributed to microvascular dysfunction (15,16). It follows that less efficient marker washout may identify those likely to benefit from glycoprotein (Gp) IIb/IIIa inhibition. In randomized trials, however, GpIIb/IIIa inhibitors did not improve prognosis, suggesting a need for individualized therapy (22). Selected clinical variables, including measurement of cardiac troponins on admission or infarct scores, may prove more useful for identification of patients who will benefit from adjunctive administration of GpIIb/IIIa inhibitors during direct PCI. Further studies are necessary to prove whether troponin testing could also be helpful to monitor the effects of GpIIb/IIIa inhibitors or other drugs on microvascular reperfusion.

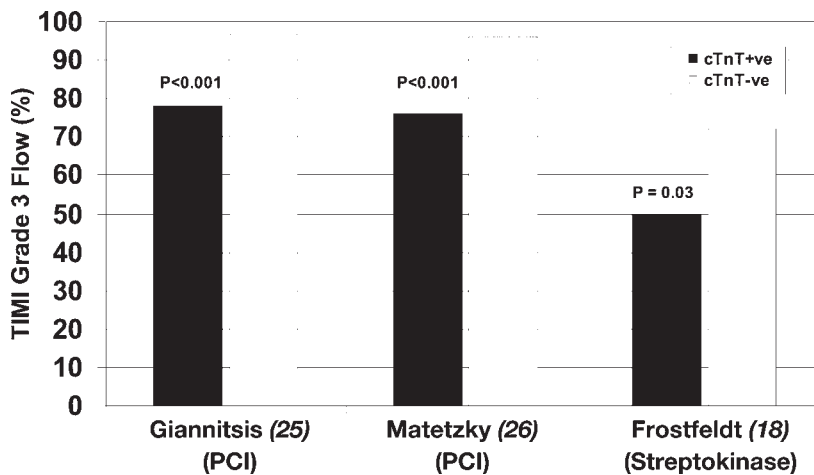
## RISK STRATIFICATION

Several randomized trials and observational studies have contributed to a consistent body of evidence that troponin levels on admission allow for early risk stratification also in patients with STEMI (23–27) (Fig. 2). In the GUSTO III troponin T substudy with 12,666 patients enrolled, 30-d mortality rates were 15.7% in patients with positive troponin results on admission compared with 6.2% among patients with negative results (23). The predictive value of cTnT was independent of age, infarct location, Killip class, systolic blood pressure, and fibrinolytic agent. Two other clinical trials confirmed the adverse prognostic association of a positive cTnT or cTnI test for patients undergoing primary PCI (25,26).

There are several potential reasons for the adverse outcomes associated with increased blood concentration of cardiac troponin. First, time delays between onset of symptoms and admission are longer for troponin-positive than for troponin-negative patients. Second, complete epicardial reperfusion is obtained less frequently in patients with already elevated cardiac troponin on admission, both after fibrinolytic therapy (18,23,24,27) and after primary PCI (25,26) (Fig. 3). Third, even after restoration of TIMI 3 grade flow with primary PCI, the prognosis remains less favorable in patients with elevated cTnT levels before the procedure (20). After adjustment for time delay and other potential confound-



**Fig. 2.** Overview of clinical trials testing prognostic impact of positive troponin value on admission. TVR, target vessel revascularization.

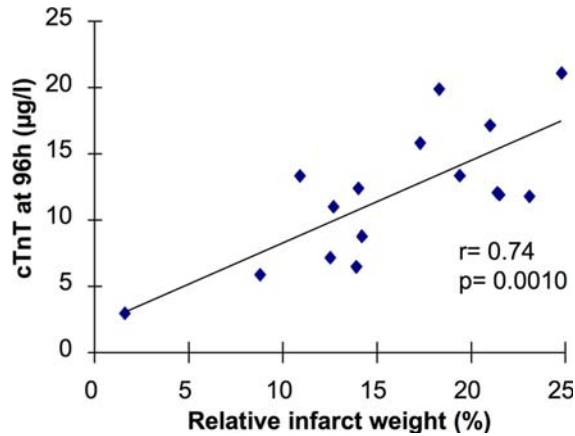


**Fig. 3.** Rates of successful reperfusion with either primary PCI or fibrinolytic therapy according to troponin status on admission.

ers, cardiac troponin remained independently associated with morbidity, suggesting a different potential pathomechanism. Therefore, it is tempting to speculate that cardiac troponin elevation might reflect a combination of ischemic burden and actual myocardial damage and may overcome some shortcomings associated with perception of pain, ischemic preconditioning, or collateral flow to the infarcted area (23). Moreover, episodes of thromboembolic microthrombosis, resulting in microvascular obstruction, may well precede the onset of STEMI (28).

### ESTIMATION OF INFARCT SIZE

Several methods may be used for estimation of infarct size including technetium-99m sestamibi single-photon emission computed tomography (SPECT), MRT, and serial assessment of markers of necrosis (29). In clinical practice, the measurement of biochemical

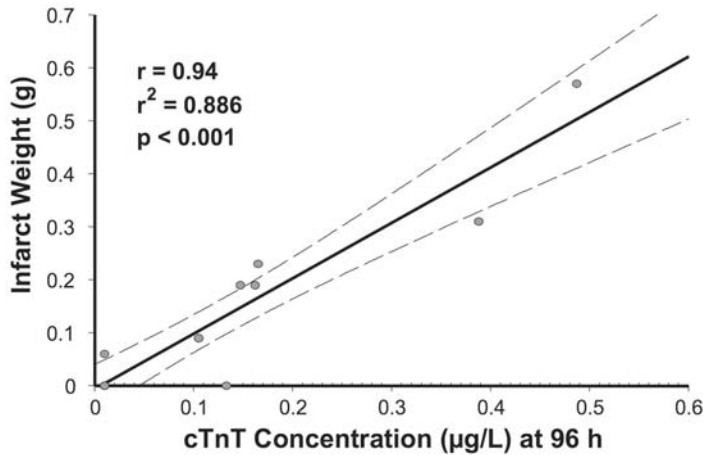


**Fig. 4.** Correlation curve between relative infarct weight and cTnT concentration at 96 h after the onset of infarction in canine model of nonreperfused AMI. (Adapted from ref. 34.)

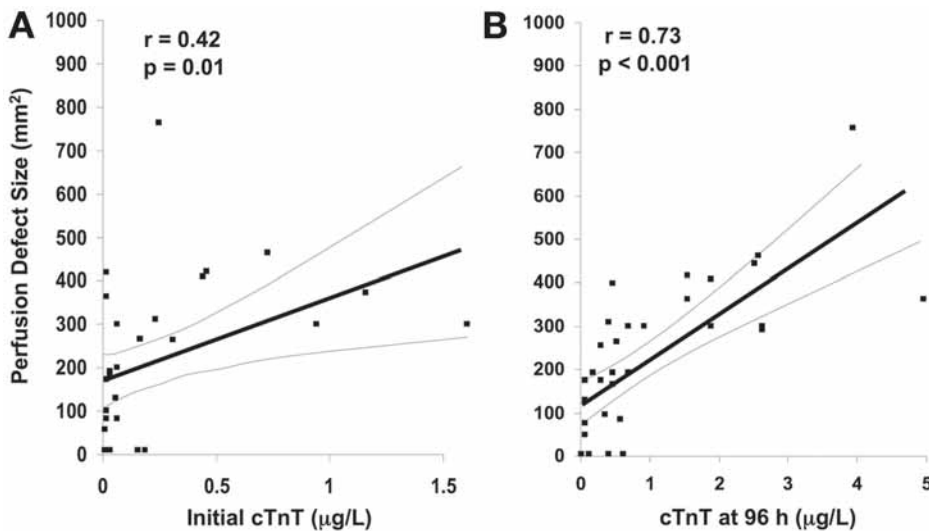
markers is most readily available and commonly performed using markers such as CK, CK-MB-isoform, hydroxybutyrate dehydrogenase, or lactic dehydrogenase.

Ideally, infarct sizing involves serial collection of cardiac markers and integration of the area under the curve of a plot of enzyme activity or protein concentration vs time. Such calculations produce an estimate of the quantity of infarcted tissue that correlates to anatomic estimates of infarct size made at autopsy (30). In clinical practice, peak levels of markers of necrosis and, less frequently, area under the time release curve of CK-MB obtained from repetitive, serial sampling are used to estimate infarct size (31). However, missing the true peak value is associated with a high likelihood of underestimation of infarct size (32). For cardiac markers that exhibit the washout phenomenon, infarct-sizing estimates are inaccurate when reperfusion of occluded coronary arteries is successful (33). In addition, the quality of reperfusion and duration of ischemia may influence the washout of the marker.

The introduction of cardiac troponin may overcome some of the limitations of this approach because troponin T or I is exclusively cardiac specific and is almost completely bound to the contractile apparatus (6). With troponin T, only the initial rapid peak, which is owing to release of the cytoplasmic pool, depends on the reperfusion status, whereas the second late peak, which is owing to degradation from the contractile apparatus, is independent of the reperfusion status (6,9). Several animal experiments have documented the usefulness of cTnT measurements for estimation of infarct size. In a canine nonreperfused experimental infarct model, Remppis et al. (34) plotted serial plasma cTnT concentrations against histochemical infarct size. They found a close relationship between area under the cTnT time release curve or peak cTnT concentrations and histological infarct size at autopsy (Fig. 4). However, the need for repetitive sampling over a long period and the possibility of incomplete recovery are costly and not practical in clinical routine. To provide a cost-effective and feasible protocol, receiver operating analysis was performed to compare the efficacy of a fixed-time protocol vs serial sampling algorithms. In the canine model, a single cTnT concentration measured at 96 h after the onset of ischemia correlated closely with histological infarct size. In humans, cTnT concentrations at 72 h after infarction were found to correlate with scintigraphically detected (thallium) infarct



**Fig. 5.** Correlation curve between infarct weight measured by contrast-enhanced MRI and cTnT concentration at 96 h after onset of infarction in rabbit model of nonreperfused AMI (unpublished data).



**Fig. 6.** Correlation between area of perfusion defect on myocardial contrast echocardiography and troponin T on admission (A) and at 96 h (B) after onset of symptoms in patients with an ACS without ST-elevation. (Adapted from ref. 37.)

size (35). Panteghini et al. (36) found that a single-point cTnT measurement at 72 h after MI correlated with infarct size measured from gated SPECT.

In a rabbit model of nonreperfused MI, areas of late hyperenhancement seen with contrast-enhanced MRT closely correlated with troponin T concentrations at 96 h after the onset of infarct (Fig. 5). This close relationship confirmed using myocardial contrast echocardiography in a series of 100 patients with ACS without ST-elevation (37) (Fig. 6).

Similarly, a correlation was found between early peak values of troponin I and the volume of infarcted nonreperfused myocardium as detected by contrast-enhanced MRT (38). Not unexpectedly, the investigators failed to demonstrate a relationship between infarct size and troponin I peak within the first 24 h after the onset of infarct, proving again that early troponin release is strongly influenced by cytoplasmic release during reperfusion (6,9).

MRT is an excellent method for quantifying myocardial infarct of <1 g and is superior to SPECT for detection of subendocardial myocardial infarcts (39,40). Forthcoming clinical studies are likely to be useful in establishing the applicability of troponin for estimation of infarct size in reperfused and nonreperfused MI. In human studies, magnetic resonance imaging (MRI) may serve as the “gold standard” against which troponin concentrations may be plotted.

Given the different release kinetics of troponin I and the heterogeneity of troponin I assays, troponin I must be validated separately and for each troponin I assay.

## CONCLUSION

Although cardiac markers of necrosis are not required for the initial diagnosis and management of patients presenting with ST-elevation on the admission of ECG, there are several very promising applications, particularly for cardiac troponins in the context of acute STEMI. First, troponin is the most valuable and precise marker for confirmation of AMI. Second, early washout of necrosis markers is a helpful complementary test for estimation of successful reperfusion after fibrinolytic therapy. It is highly likely that this also relates to mechanically recanalized infarct-related arteries. Third, patients with detectable amounts of troponin on admission have a less favorable short- and long-term prognosis. Although the underlying pathobiology is still not completely understood, the hypothesis is proposed that troponin on admission might serve as a surrogate for the presence or development of microvascular obstruction. The fact that admission troponin status proved helpful for identification of patients who had an incremental benefit from the platelet GpIIb/IIIa inhibitor abciximab after already successful epicardial reperfusion has supported this hypothesis. Finally, a remarkably consistent body of evidence demonstrates that measurement of cardiac markers during the early postinfarction period allows accurate estimation of infarct size. For cTnT, a single determination at 72–96 h post-STEMI onset adequately reflects infarct size.

## REFERENCES

1. Antman EM, Anbe DT, Armstrong PW, et al. ACC/AHA guidelines for the management of patients with ST-elevation myocardial infarction—executive summary. A report of the American College of Cardiology/American Heart Association Task Force on Practice Guidelines (Writing Committee to revise the 1999 guidelines for the management of patients with acute myocardial infarction). *J Am Coll Cardiol* 2004;44:671–719.
2. Chan CP, Sanderson JE, Glatz JF, Cheng WS, Hempel A, Renneberg R. A superior early myocardial infarction marker: human heart-type fatty acid-binding protein. *Z Kardiol* 2004;93:388–397.
3. Report of the Joint International Society and Federation of Cardiology/World Health Organization Task Force on standardization of clinical nomenclature. *Circulation* 1979;59:607–609.
4. The Joint European Society of Cardiology/American College of Cardiology Committee. Myocardial infarction redefined—a consensus document of the Joint European Society of Cardiology/American College of Cardiology Committee for the redefinition of myocardial infarction. *Eur Heart J* 2000;21:1502–1513.
5. Katus HA, Remppis A, Neumann FJ, et al. Diagnostic efficiency of troponin T measurements in acute myocardial infarction. *Circulation* 1991;83:902–912.
6. Katus HA, Remppis A, Scheffold T, et al. Intracellular compartmentation of cardiac troponin T and its release kinetics in patients with reperfused and nonreperfused myocardial infarction. *Am J Cardiol* 1991; 67:1360–1367.
7. Krucoff MW, Croll MA, Pope JE, et al., for the TAMI 7 study. Performance of a noninvasive method for real-time detection of failed myocardial reperfusion. *Circulation* 1993;88:437–446.

8. Langer A, Krucoff MW, Klootwijk P, et al. Noninvasive assessment of speed and stability of infarct-related artery reperfusion: results of the GUSTO ST segment monitoring study: global utilization of streptokinase and tissue plasminogen activator for occluded coronary arteries. *J Am Coll Cardiol* 1995;25:1552–1557.
9. Katus HA, Diederich KW, Scheffold T, Uellner M, Schwarz F, Kübler W. Non-invasive assessment of infarct reperfusion: the predictive power of the time to peak value of myoglobin, CKMB, and CK in serum. *Eur Heart J* 1988;9:619–624.
10. Apple FS. Value of soluble markers in the diagnosis of reperfusion. In: Kaski JC, Holt DW, eds. *Developments in Cardiovascular Medicine: Myocardial Damage—Early Detection by Novel Biochemical Markers*. Kluwer Academic, Dordrecht, The Netherlands, 1998, pp. 149–157.
11. Stewart JT, French JK, Theroux P, et al. Early non-invasive identification of failed reperfusion after intravenous thrombolytic therapy in acute myocardial infarction. *J Am Coll Cardiol* 1998;31:1499–1505.
12. Tanasijevic MJ, Cannon CP, Antman EM, et al., for the TIMI 10B Investigators. Myoglobin, creatine kinase MB and cardiac troponin I 60-minute ratios predict infarct-related artery patency after thrombolysis for acute myocardial infarction. *J Am Coll Cardiol* 1999;34:739–747.
13. Apple FS, Henry TD, Berger CR, Landt YA. Early monitoring of serum cardiac troponin I for assessment of coronary reperfusion following thrombolytic therapy. *Am J Clin Pathol* 1996;105:6–10.
14. Zabel M, Hohnloser SH, Koster W, Prinz M, Kasper W, Just H. Analysis of creatine kinase, CK-MB, myoglobin, and troponin T time-activity curves for early assessment of coronary artery reperfusion after intravenous thrombolysis. *Circulation* 1993;87:1542–1550.
15. Wu K, Zerhouni EA, Judd RM, et al. Prognostic significance of microvascular obstruction by magnetic resonance imaging in patients with acute myocardial infarction. *Circulation* 1998;97:765–772.
16. Ito H, Tomooka T, Sakai N, et al. Lack of myocardial perfusion immediately after successful thrombolysis: a predictor of poor recovery of left ventricular function in anterior myocardial infarction. *Circulation* 1992;85:1699–1705.
17. Laperche T, Steg PG, Benessiano J, et al. Patterns of myoglobin and MM creatine kinase isoforms release early after intravenous thrombolysis or direct percutaneous transluminal coronary angioplasty for acute myocardial infarction, and implications for the early noninvasive diagnosis of reperfusion. *Am J Cardiol* 1992;70:1129–1134.
18. Frostfeldt G, Gustafsson G, Lindahl B, Nygren A, Venge P, Wallentin L. Possible reasons for the prognostic value of troponin-T on admission in patients with ST-elevation myocardial infarction. *Coron Artery Dis* 2001;12:227–237.
19. Lehrke S, Katus HA, Giannitsis E. Admission troponin T predicts benefits abciximab administration after successful primary percutaneous intervention for acute ST-segment myocardial infarction. *Thromb Haemost* 2004;92:1214–1220.
20. Wong GC, Morrow DA, Murphy S, et al. Elevations in troponin T and I are associated with abnormal tissue level perfusion: a TACTICS-TIMI 18 substudy. *Treat Angina with Aggrastat and Determine Cost of Therapy with an Invasive or Conservative Strategy-Thrombolysis in Myocardial Infarction*. *Circulation* 2002;106:202–207.
21. Kurowski V, Hartmann F, Killermann DP, et al. Prognostic significance of admission cardiac troponin T in patients treated successfully with direct percutaneous interventions for acute ST-segment elevation myocardial infarction. *Crit Care Med* 2002;30:2229–2235.
22. Topol EJ; GUSTO V Investigators. Reperfusion therapy for acute myocardial infarction with fibrinolytic therapy or combination reduced fibrinolytic therapy and platelet glycoprotein IIb/IIIa inhibition: the GUSTO V randomised trial. *Lancet* 2001;357:1905–1914.
23. Ohman EM, Armstrong PW, White HD, for the GUSTO-III Investigators. Risk stratification with a point-of care cardiac troponin T test in acute myocardial infarction. *Am J Cardiol* 1999;84:1281–1286.
24. Stubbs P, Collinson P, Moseley D, et al. Prognostic significance of admission troponin T concentrations in patients with myocardial infarction. *Circulation* 1996;94:1291–1297.
25. Giannitsis E, Lehrke S, Wiegand U, et al. Risk stratification in patients with inferior acute myocardial infarction treated by percutaneous coronary interventions—the role of admission troponin T. *Circulation* 2000;102:2038–2044.
26. Matetzky S, Sharir T, Domingo M, et al. Elevated troponin I level on admission is associated with adverse outcome of primary angioplasty in acute myocardial infarction. *Circulation* 2000;102:1611–1616.
27. Björklund E, Lindahl B, Johanson P, et al. Admission Troponin T and measurement of ST-segment resolution at 60 min improve early risk stratification in ST-elevation myocardial infarction. *Eur Heart J* 2004;25:113–120.



28. Falk E. Unstable angina with fatal outcome: dynamic coronary thrombosis leading to infarction and/or sudden death. Autopsy evidence of recurrent mural thrombosis with peripheral embolization culminating in total vascular occlusion. *Circulation* 1985;71:699–708.
29. Gibbons RJ, Valeti US, Araoz PA, Jaffe AS. The quantification of infarct size. *J Am Coll Cardiol* 2004;44:1533–1542.
30. Grande P, Christiansen C, Alstrup K. Comparison of ASAT, CK, CK-MB, and LD for the estimation of acute myocardial infarct size in man. *Clin Chim Acta* 1983;128:329–335.
31. Al Saady NM, Camm AJ. New soluble markers for assessment of infarct size. In: Kaski JC, Holt DW, eds. *Myocardial Damage: Early Detection by Novel Biochemical Markers*. Kluwer Academic, Dordrecht, The Netherlands, 1998, pp. 137–148.
32. Smith JL, Ambos HD, Gold HK, et al. Enzymatic estimation of myocardial infarct size when early creatine kinase values are not available. *Am J Cardiol* 1983;51:1294–1300.
33. Vatner SF, Baig H, Manders WT, Maroko PR. Effects of coronary artery reperfusion on myocardial infarct size calculated from creatine kinase. *J Clin Investig* 1977;61:1048–1056.
34. Remppis A, Ehlermann P, Giannitsis E, et al. Cardiac troponin T levels at 96 hours reflect myocardial infarct size: a pathoanatomical study. *Cardiology* 2000;93:249–253.
35. Licka M, Zimmermann R, Zehelein J, Dengler TJ, Katus HA, Kubler W. Troponin T concentrations 72 hours after myocardial infarction as a serological estimate of infarct size. *Heart* 2002;87:520–524.
36. Panteghini M, Cuccia C, Bonetti G, Giubbini R, Pagani F, Bonini E. Single-point cardiac troponin T at coronary care unit discharge after myocardial infarction correlates with infarct size and ejection fraction. *Clin Chem* 2002;48:1432–1436.
37. Korosoglou G, Labadze N, Hansen A, et al. Usefulness of real-time myocardial perfusion imaging in the evaluation of patients with first time chest pain. *Am J Cardiol* 2004;94:1225–1231.
38. Ingkanisorn WP, Rhoads KL, Aletras AH, Kellman P, Arai AE. Gadolinium delayed enhancement cardiovascular magnetic resonance correlates with clinical measures of myocardial infarction. *J Am Coll Cardiol* 2004;43:2253–2259.
39. Ricciardi MJ, Wu E, Davidson CJ, et al. Visualization of discrete microinfarction after percutaneous coronary intervention associated with mild creatine kinase-MB elevation. *Circulation* 2001;103:2780–2783.
40. Wagner A, Mahrholdt H, Holly TA, et al. Contrast-enhanced MRI and routine single photon emission computed tomography (SPECT) perfusion imaging for detection of subendocardial myocardial infarcts: an imaging study. *Lancet* 2003;361:374–379.

# 7

---

## Cardiac Troponin After Revascularization Procedures

---

*Warren J. Cantor, MD,  
and L. Kristin Newby, MD, MHS*

### CONTENTS

INTRODUCTION  
ELEVATED TROPONIN LEVELS AFTER PCI  
ELEVATED TROPONIN LEVELS AFTER CABG  
CONCLUSION  
REFERENCES

---

### SUMMARY

A significant proportion (~20%) of patients undergoing percutaneous coronary intervention (PCI) or coronary artery bypass graft (CABG) surgery develop elevated levels of creatine kinase MB isoform (CK-MB) afterward. Large increases in the concentration of CK-MB after PCI are associated with the risk of death, myocardial infarction, and repeat revascularization. However, the prognostic significance of modest elevations (less than five times the upper limit of normal [ULN]) after PCI remains controversial. It has been shown in some studies have shown that even minor elevations in CK or CK-MB levels (more than one time the ULN) after PCI are associated with worse outcomes, but other studies have shown no association between small elevations in CK or CK-MB (less than five times the ULN) and recurrent cardiac events. Following CABG, almost all patients have elevated levels of CK-MB and the clinical significance is less well established. However, clinical studies show that large elevations (more than five times ULN) are associated with worse prognosis. Cardiac troponin is elevated more frequently after PCI and CABG. A number of procedure-related factors contribute to the rises in troponin, including unrecognized complications of PCI (distal embolization, minor side-branch occlusion), inflammation, direct cardiac manipulation, and direct current defibrillation during CABG. Although troponin levels are helpful in diagnosing periprocedural myonecrosis as well as predicting long-term outcomes, the optimal diagnostic and prognostic cutoff levels remain to be determined. Moreover, to date, the appropriate clinical response to these findings remains uncertain.

**Key Words:** Troponin; myocardial infarction; prognosis; diagnosis; revascularization; angioplasty.

From: *Contemporary Cardiology:  
Cardiovascular Biomarkers: Pathophysiology and Disease Management*  
Edited by: David A. Morrow © Humana Press Inc., Totowa, NJ

## INTRODUCTION

It has long been recognized that a significant proportion of patients undergoing percutaneous coronary intervention (PCI) or coronary artery bypass graft (CABG) surgery develop elevated levels of creatine kinase (CK) or its MB isoform (CK-MB) after the procedure. After PCI, approx 20% of patients have elevated CK or CK-MB (1). Many studies have shown associations between large increases in the concentration of CK or CK-MB after PCI and the subsequent risk of death, myocardial infarction (MI), and repeat revascularization. However, the prognostic significance of modest elevations (less than five times the upper limit of normal [ULN]) after PCI remains controversial. Some studies have shown that even minor elevations in CK or CK-MB levels (more than one time the ULN) after PCI are associated with worse outcomes (2,3), but other studies have shown no association between small elevations in CK or CK-MB (less than five times the ULN) and recurrent cardiac events (4,5). Among patients who have elevated levels of CK-MB or troponin after PCI, magnetic resonance imaging shows small focal areas of MI in the region supplied by the treated vessel, thus confirming that these elevations result from myocardial necrosis (6,94).

After CABG, almost all patients have elevated levels of CK-MB (7). The significance of elevated CK or CK-MB after CABG has not been investigated as closely, but several studies indicate that significant increases in the concentration of CK-MB (more than five times the ULN) after CABG are associated with worse long-term outcomes (7,8). In addition, levels of CK-MB >19 IU/L have been associated with new perfusion defects on single-photon emission computed tomography myocardial perfusion imaging (9).

Cardiac troponin is more sensitive and more specific than CK or CK-MB for the detection of myocardial necrosis (see Chapter 4). Therefore, it is expected that levels of troponin will be elevated more often than CK or CK-MB after revascularization procedures. Nevertheless, the prognostic significance of abnormal troponin results after PCI/CABG has not been as extensively studied as for CK and CK-MB.

### ELEVATED TROPONIN LEVELS AFTER PCI

#### *Incidence of Elevated Troponin Levels After PCI*

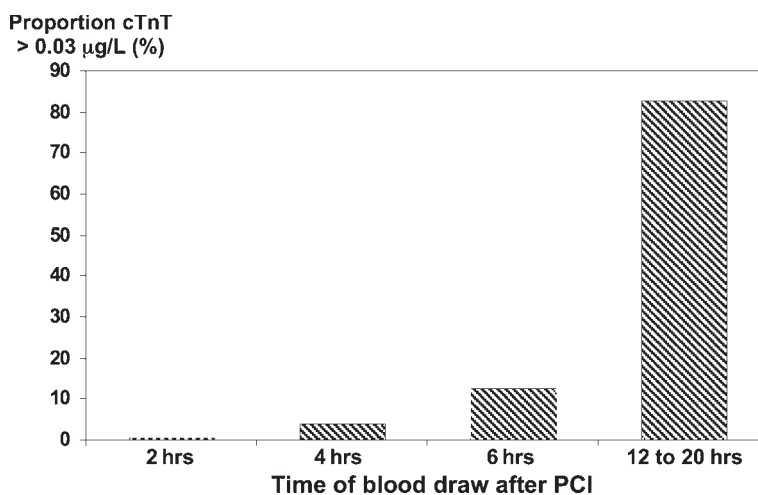
The incidence of elevated levels of troponin after PCI or CABG depends on the patient population, the type of intervention (10), the timing of blood sampling (11), and the troponin assay (Fig. 1). Although there is only one single troponin T assay, there are approx 15 different commercially available assays for troponin I (12). Even among studies using the same troponin assays, different cutoff values are used for positivity post-PCI. As seen in Table 1, the reported incidence of elevated troponin after PCI varies from 0 to 56%.

#### *Mechanisms/Predictors of Elevated Troponin Levels After PCI*

The pathophysiological mechanism for elevated cardiac troponin levels after PCI is unclear. Potential mechanisms include myocardial necrosis or ischemia from prolonged balloon inflations, transient abrupt closure, distal embolization, and side-branch occlusion.

### PROLONGED BALLOON INFLATIONS

In two series of patients undergoing PCI, elevated postprocedural levels of troponin correlated closely with long balloon-inflation times (13,14). Katoh et al. (15) studied 16 patients undergoing PCI with measurements of coronary sinus troponin T immediately after and 4, 8, and 12 h after PCI. Despite inflations up to 64 s associated with chest pain



**Fig. 1.** Proportion of patients with increased concentration of troponin T (cTnT) with serial measurement after elective PCI ( $n = 52$ ). (Data from ref. 11.)

and ST-segment changes in all patients, the concentration of troponin T in samples from the femoral vein and coronary sinus remained within normal limits in all patients over the 12-h period. It therefore seems unlikely that balloon inflation alone leads to troponin release in the absence of distal embolization, side-branch occlusion, or other procedural complications.

#### **SIDE-BRANCH OCCLUSION, ABRUPT CLOSURE, AND OTHER PROCEDURAL COMPLICATIONS**

In several small series, troponin elevation was found to occur mostly or exclusively when procedural complications, particularly side-branch occlusion, occurred (16,17). In multivariable models, side-branch occlusion and other procedural complications are identified as independent predictors of troponin elevation (10,18,19). More than 80% of patients with elevated troponin post-PCI have no identifiable procedural or angiographic complications (10,20). However, distal embolization may not be angiographically apparent, and occlusion of very small side branches is easily missed. Patients with acute coronary syndromes (ACS) who have elevated levels of troponin I post-PCI are significantly more likely to have evidence of impaired tissue-level perfusion T(m) (thrombolysis in myocardial infarction) myocardial perfusion grade 0/1 and reduced perfusion on myocardial contrast echocardiogram than patients without postprocedural troponin I elevation (Fig. 2) (21).

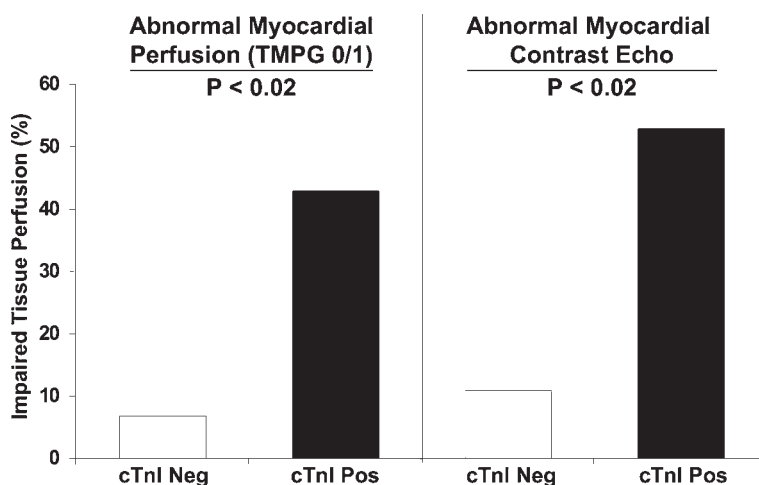
#### **STENTING VS BALLOON ANGIOPLASTY**

Several observational studies have documented higher rates of troponin elevation following coronary stenting compared with balloon angioplasty alone (18,22–24). However, in other studies, there were no significant differences in levels of troponin with stenting vs angioplasty alone (13,19,20). Coronary stents may increase the frequency of minor myonecrosis by occlusion of small side branches or increased distal embolization. Alternatively, the difference may be related to the more frequent use of stents in more complex vessels and lesions. In two studies, the use of stents was no longer associated with troponin elevation after adjusting for confounding variables in a multivariable model (18,25). The use of multiple stents has been shown to be an independent predictor of troponin

Table 1  
Incidence of Elevated Troponin After PCI

<i>Reference/ year of publication</i>	<i>No. of patients</i>	<i>Troponin T or I</i>	<i>Type of assay<sup>a</sup></i>	<i>Patients with positive Tn (%)</i>
(38) 2003	158	T	Boehringer Cardiac Reader	13
(37) 2003	153	T	Boehringer Cardiac Reader	11
(81) 1998	44	I	Dade Stratus II	36
(13) 1999	105	T	Roche Elecsys STAT	18
(13) 1999	105	I	Sanofi	22
(82) 2002	96	T	Roche Elecsys 2010	0
(22) 2002	481	I	Dade Dimension	26
(20) 2000	1129	I	Beckman	31
(83) 1999	109	I	Dade Stratus II	27
(32) 1997	80	T	Boehringer ES300	21
(32) 1997	80	I	ERIA	21
(30) 2002	116	I	Beckman	43
(35) 2000	104	T	Boehringer ES300	37
(35) 2000	104	I	Bayer Immuno-1	56
(84) 2002	278	T	Roche Bedside Cardiac T	17
(85) 1991	22	I	NA	0
(14) 1998	75	T	Boehringer ES301	28
(86) 1995	25	T	NA	44
(40) 2002	180	I	Abbott Ax Sym	27
(87) 2004	2873	I	Abbott Ax Sym	39
(29) 2003	125	T	Roche Elecsys 2010	18
(42) 2000	100	I	NA	12
(17) 1996	44	T	Boehringer ES300	9
(17) 1996	44	I	Dade Stratus II	25
(10) 2004	405	I	Abbott Ax Sym	27
(11) 2004	57	T	Roche Elecsys	42
(33) 2002	344	I	Bayer Immuno-1	18
(18) 2004	1128	I	Abbott Ax Sym	17
(27) 2004	153	I	Beckman Coulter	34
(88) 1994	23	T	Boehringer ES22	13
(89) 1997	80	T	Boehringer ES300	0
(90) 2000	48	I	Dade Stratus II	29
(19) 2003	286	I	Abbott Ax Sym	14
(41) 1995	61	T	NA	35
(26) 2002	85	I	Abbott Ax Sym	29
(91) 2002	96	I	Abbott Ax Sym	27
(31) 2001	98	I	Abbott Ax Sym	27
(31) 2001	98	T	Roche Elecsys 2010	18
(43) 2002	24	T	Roche ECLusys TnT III	38
(25) 2004	522	I	Abbott Ax Sym	41
(24) 1998	120	T	Boehringer ES600	21
(92) 1997	25	T	Boehringer ES300	4
(34) 1998	72	I	Sanofi	21
(34) 1998	72	T	Boehringer ES300	22
(16) 1992	21	T	Boehringer	19
(93) 2002	98	T	Roche	0

<sup>a</sup>NA, not available.



**Fig. 2.** Evidence for impaired tissue-level myocardial perfusion by angiography and myocardial contrast echocardiography in patients with elevated levels of troponin after PCI. TMPG, TIMI myocardial perfusion grade. (Data from ref. 52.)

elevation in some studies (10,25). There are no randomized trials comparing the rates of troponin elevation after coronary stenting with those after balloon angioplasty alone.

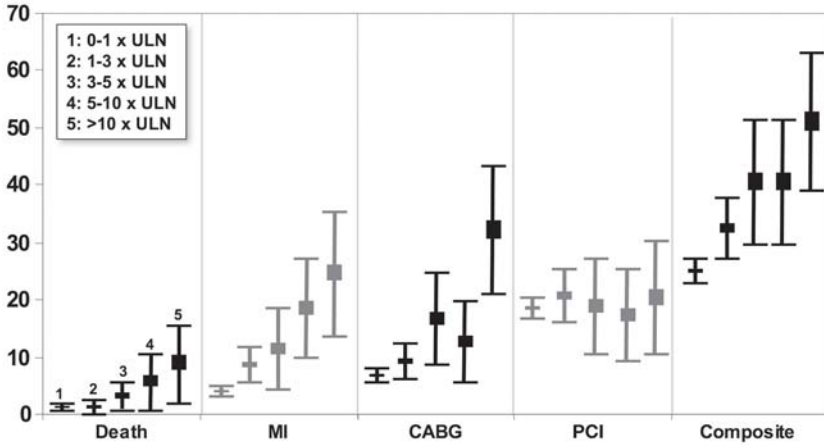
#### ASSOCIATION WITH INFLAMMATION

A recent study showed that the concentration of C-reactive protein (CRP) is frequently increased after PCI, and that elevated CRP is associated with higher rates of troponin elevation (26). This finding suggests that systemic inflammation may be involved in the etiology of periprocedural myonecrosis. This intriguing hypothesis is further supported by a trial demonstrating lower rates of post-PCI troponin elevation in patients who are pre-medicated with atorvastatin, which has been shown to reduce CRP level significantly (27). Alternatively, increases in acute-phase proteins may reflect the inflammatory response to small areas of myonecrosis.

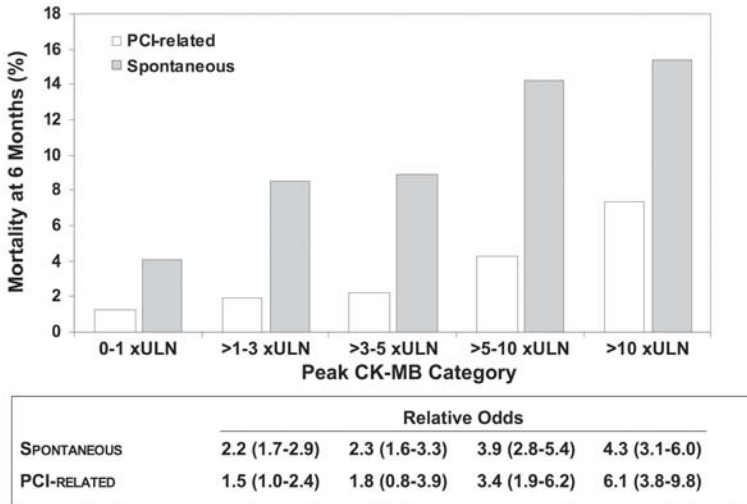
#### *Prognostic Significance of Elevated Troponin Levels After PCI*

Many studies have documented an association between elevated CK or CK-MB levels after PCI and increased risk of adverse cardiac events at intermediate- and long-term follow-up (1). However, there has been inconsistency as to whether even modest elevations in CK or CK-MB are associated with adverse outcomes. Some studies have shown a direct relationship between the degree of periprocedural myonecrosis and the risk of long-term complications (Fig. 3) (2), whereas others have found increased complications only with large elevations in cardiac enzymes. In one meta-analysis, a linear association between CK-MB elevation post-PCI and 6-mo mortality was demonstrated (28). Although absolute mortality rates are higher after spontaneous MI, the relative increase in mortality for increasing levels of CK-MB elevation are similar for periprocedural and spontaneous MI (Fig. 4) (28). It remains unclear whether there is a direct causal relationship between periprocedural myonecrosis and long-term complications, or whether cardiac marker elevations are simply a marker for high-risk lesion, vessel, or patient characteristics.

Table 2 provides the studies that have evaluated the prognostic significance of elevated levels of troponin after PCI. Most, but not all, studies found a significant association between troponin results and adverse outcomes (Fig. 5). In some studies, the association



**Fig. 3.** Point estimates and 95% confidence intervals for frequency of cardiac events through 6 mo after PCI stratified by postprocedural concentration of CK-MB. PCI, percutaneous coronary intervention.



**Fig. 4.** Absolute and relative risk of mortality at 6 mo after spontaneous vs PCI-related increases in concentration of CK-MB. (Data from ref. 54.)

was no longer significant with longer follow-up or after adjustment for baseline characteristics (18,20). Some studies found a significant association with outcomes only when the troponin elevation was more than three to five times the ULN (19,20,29). Although uncertainty remains regarding the specificity and significance of troponin elevations in patients with renal failure, Gruberg et al. (30) found that postprocedural troponin elevation was an independent predictor of mortality at 1 yr among patients with renal failure undergoing PCI. The discrepancies among studies may relate to the differences in patient populations, sample sizes, duration of follow-up, and sensitivities of the troponin assays that were used.

### Troponin I vs Troponin T

Several studies have simultaneously measured troponin I and troponin T levels after PCI (13,17,31–35). In most studies, troponin I appeared to be more sensitive for detecting

Table 2  
Studies Relating Post-PCI Troponin Levels and Clinical Outcomes<sup>a</sup>

Reference/ year of publication	Troponin assay	Patient population	Clinical outcomes	Duration of follow-up	Main results
(93) 2002	TnT (Roche)	Successful PCI (n = 90)	Death, MI, CABG, repeat PCI	77 mo	No difference in outcomes based on TnT positivity
(91) 2002	TnI (Abbott Ax Sym)	Stable angina (n = 96)	Cardiac death, MI, CABG, repeat PCI, recurrent angina	24 mo	Increased recurrent angina and repeat intervention with TnI positivity
(90) 2000	TnI (Dade Stratus II)	MI, unstable angina, CAD (n = 60)	Cardiac death, MI, CABG, repeat PCI, cardiac hospitalization	30 d	Higher risk of recurring unstable angina with TnI positivity
(84) 2002	TnT (Roche Bedside Cardiac T)	Single-vessel PCI (n = 278)	Cardiac death, MI, CABG, repeat PCI, cardiac hospitalization	6 mo	Higher risk of death, MACE with TnI positivity
(30) 2002	TnI (Beckman)	Chronic renal insufficiency (n = 116)	Death, Q-wave MI, TLR	12 mo	Higher mortality with TnI positivity, independent predictor of late mortality
(81) 1998	TnI (Dade Stratus II)	Successful PCI (n = 44)	Death, MI, unstable angina, CABG	3.8 ± 1.1 yr	No difference in outcomes based on TnI positivity
(33) 2003	TnI (Bayer Immuno-1) + TnT (Roche ES300)	Stable angina, unstable angina (n = 109)	Cardiac death, Q-wave MI, CABG, repeat PCI	53–82 wk	Higher long-term MACE with TnI or TnT positivity
(83) 1999	TnI (Dade Stratus II)	Consecutive PCI (n = 109)	Death, MI, repeat PCI	8 ± 3 mo	Postprocedure TnI not a predictor of late events
(20) 2000	TnI (Beckman)	Consecutive PCI (n = 1129)	Death, Q-wave MI, TLR	8 mo	TnI > 3 times normal limit associated with increased complications in hospital but not at 8 mo

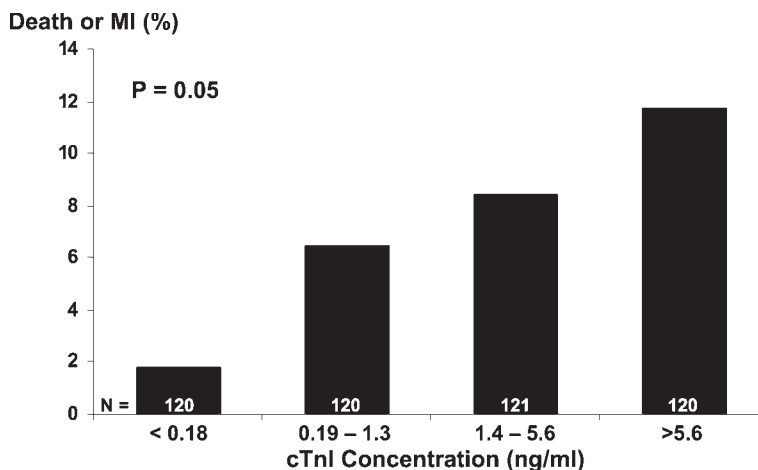
(continued)



Table 2 (Continued)

<i>Reference/ year of publication</i>	<i>Troponin assay</i>	<i>Patient population</i>	<i>Clinical outcomes</i>	<i>Duration of follow-up</i>	<i>Main results</i>
(18) 2004	TnI (Abbott Ax Sym)	PCI with normal post-PCI CK level ( <i>n</i> = 1128)	Death, CABG, repeat PCI, cardiac admissions	1 yr	Higher 1-yr event rate with TnI elevation; TnI > 5 times ULN an independent predictor of in-hospital but not 1-yr events
(40) 2004	TnI (Abbott Ax Sym)	PCI ( <i>n</i> = 2873)	Death	12 ± 6 mo	TnI post-PCI not predictive of mortality
(29) 2003	TnT (Roche Elecsys 2010)	Consecutive PCI ( <i>n</i> = 212)	Death, MI, repeat PCI, CABG	5.6 yr	Elevated TnT an independent predictor of MACE at 1 yr; TnT > 5 times ULN a predictor of lower long-term event-free survival
(13) 1999	TnI (Sanofi) + TnT (Roche Elecsys STAT)	Consecutive PCI ( <i>n</i> = 105)	Cardiac death, MI, repeat PCI, CABG, recurrent angina	16 mo	No difference in outcomes based on TnI positivity
(19) 2003	TnI (Abbott Ax Sym)	Consecutive PCI ( <i>n</i> = 471)	Death, MI, repeat PCI, CABG	445 d	TnI > 3 times ULN an independent predictor of long-term MACE
(22) 2002	TnI (Dade Dimension)	ACS ( <i>n</i> = 481)	Death, MI, severe recurrent ischemia	90 d	Elevated TnI post-PCI associated with higher rate of death/MI

CAD, coronary artery disease; MACE, major adverse cardiac events; TnI, troponin I; TnT, troponin T; TLR, target lesion revascularization.



**Fig. 5.** Relationship between cardiac troponin I (cTnI) post-PCI and risk of subsequent death or MI through 90 d. (Data from ref. 18.)

periprocedural myonecrosis (17,31,33,35), although other studies found similar rates of elevation post-PCI. None of these studies were adequately powered to determine whether one troponin assay was more predictive of adverse clinical outcomes after PCI.

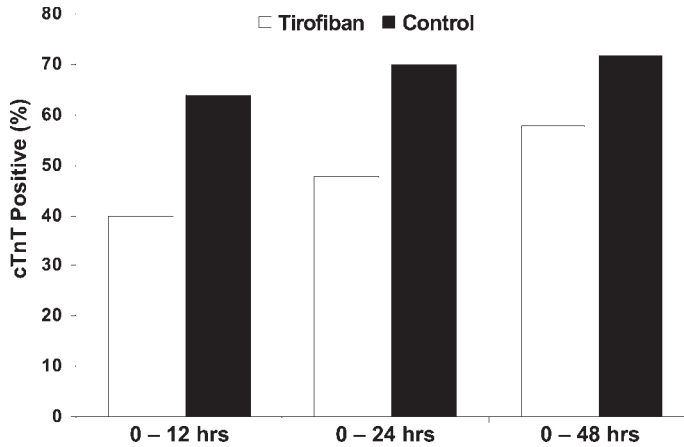
### ***Importance of Measuring Baseline Preprocedural Troponin***

Patients undergoing PCI within 2 wk of an ACS will often have elevated troponin levels pre-PCI. Gustavsson et al. (36) have showed that among patients with elevated preprocedural troponin, postprocedural levels of troponin do not correlate well with CK-MB and may not represent periprocedural myocardial injury. Therefore, it is essential to measure the preprocedural troponin level and/or postprocedural CK-MB level to avoid misdiagnosis of periprocedural myonecrosis. Measurement of preprocedural troponin may also improve the ability to predict adverse clinical outcomes based on postprocedural troponin levels. In one study, patients with recent ACS and persistent elevation of troponin undergoing PCI had a hazard ratio of 2.7 for death or MI at 90 d associated with abnormal periprocedural troponin results, whereas the hazard ratio was 4.3 for patients known to have negative troponin levels before the procedure (22).

### ***Prevention of Elevated Troponin Levels After PCI***

A number of pharmacological agents have been shown to reduce the frequency and/or severity of periprocedural myonecrosis as measured by postprocedural levels of troponin. Because microembolization of thrombus is believed to be one of the primary causes of periprocedural myonecrosis, it is not surprising that more potent antiplatelet agents, such as the thienopyridines and the iv glycoprotein IIb/IIIa receptor inhibitors, and more potent inhibitors of thrombin reduce the frequency of this complication.

In one retrospective, nonrandomized analysis, patients pretreated with ticlopidine prior to coronary stenting had lower frequency and magnitude of increase in the concentration of troponin T compared with patients who started taking ticlopidine the day of the procedure (37). A small randomized trial of clopidogrel vs ticlopidine started on the day of PCI showed less troponin T elevation and lower mean troponin T values after PCI with clopidogrel (38).



**Fig. 6.** Proportion of patients with elevated cTnT after PCI when treated with adjunctive tirofiban vs control. (Data from ref. 17.)

Tirofiban started prior to the first balloon inflation and continued for 18 h post-PCI was shown in a randomized, placebo-controlled trial to reduce the frequency of troponin T elevation at 24 h (48 vs 69%;  $p < 0.05$ ), although the difference at 48 h was no longer statistically significant (Fig. 6). The reduced frequency of troponin and CK-MB elevations post-PCI with the use of glycoprotein IIb/IIIa inhibitor is thought to be related to reduced periprocedural myonecrosis, rather than an interaction between this class of drugs and the cardiac marker assays (39). Kini et al. (40) performed a randomized trial of eptifibatid, tirofiban, or abiciximab during PCI, with additional half boluses of the study drug given 10 min later if  $<90\%$  inhibition of platelet aggregation was achieved. There was no difference in the incidence of troponin I elevation  $>2.0$  ng/mL post-PCI between the different glycoprotein IIb/IIIa receptor inhibitors.

In a randomized trial of patients with unstable angina undergoing PCI that compared hirudin, a direct thrombin inhibitor, with heparin, both doses of hirudin used were more effective than heparin in preventing troponin T elevations  $>0.2$  ng/mL post-PCI (24 vs 58%;  $p = 0.01$ ) (41).

The use of other classes of drugs has also been examined in relation to the incidence of post-PCI troponin elevation. Intravenous nitroglycerine started immediately after PCI and continued for 12 h was shown to be superior to placebo in reducing the frequency of troponin I elevation  $>0.1$   $\mu\text{g/L}$  at 12 h post-PCI (5 vs 19%;  $p = 0.036$ ) (42). This finding may be related to the improved coronary blood flow and myocardial perfusion that occur with iv nitroglycerine. Interventions that induce ischemic preconditioning, such as nicorandil, may also reduce the frequency of minor myocardial damage during PCI (43). A randomized, placebo-controlled trial of atorvastatin (40 mg/d) started 7 d prior to PCI demonstrated a marked reduction in troponin I elevation (20 vs 48%;  $p = 0.0004$ ) in the first 24 h after PCI (27). Given the effect of atorvastatin on reducing CRP levels and the association of CRP with elevated troponin post-PCI (26), it has been postulated that atorvastatin prevents periprocedural myonecrosis through its anti-inflammatory properties.

A number of mechanical approaches reduce periprocedural MI, as assessed by CK-MB, including the use of distal embolization protection devices for saphenous vein graft interventions (44), and direct stenting without predilation (45). The impact of these strategies on troponin release post-PCI has not been studied.

### *Management of Patients With Elevated Troponin Levels After PCI*

As the prognostic significance of elevated troponin after PCI continues to be debated, with no clearly defined threshold levels for increased risk, no firm recommendations can be made for the management of patients who have elevated troponin after PCI. With marked elevations in post-PCI troponin, it may be reasonable to delay hospital discharge by an additional day for observation or until the biomarker is no longer rising, particularly when there is also a marked rise in CK-MB levels.

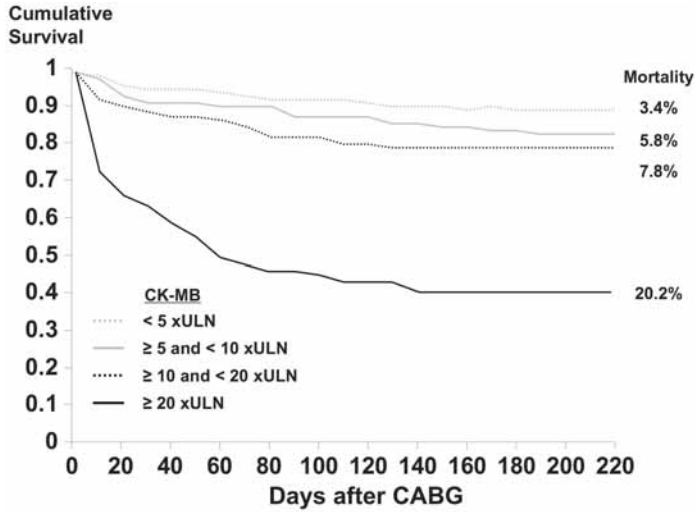
Intuitively, it would be anticipated that patients with periprocedural myonecrosis would derive the same benefit from long-term secondary prevention, including  $\beta$ -blockers and angiotensin-converting enzyme inhibitors, as those patients with non-procedure-related MI. However, these therapies have not been proven to be beneficial in this setting. One study suggested that pretreatment with oral  $\beta$ -blockers reduced the frequency of CK elevation after PCI and improved mortality independent of the effect on CK elevation (46). However, no difference in CK elevation was seen in another large registry (47), and the improvement in long-term mortality post-PCI was mainly limited to patients who had previous MI (48).

### ELEVATED TROPONIN LEVELS AFTER CABG

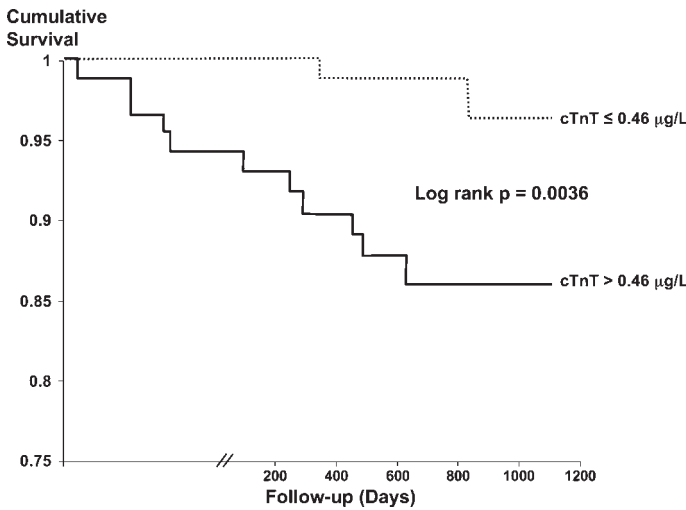
The concentration of troponin is elevated in almost all patients after bypass surgery, with marked increases in 20–40% of patients (7,49–54). Several studies have shown lower postoperative troponin levels with minimally invasive and off-pump surgical techniques (55–62). The type and route of delivery of cardioplegia may also influence the perioperative release of troponin (63–65).

Postoperative troponin levels have greater sensitivity and specificity for the diagnosis of perioperative MI (based on electrocardiographic changes, wall motion abnormalities, and/or scintigraphic perfusion defects) than CK-MB (50,51,66–69). However, CK-MB may be more sensitive than troponin in the first 12 h after surgery (70). Postoperative troponin levels are higher in patients with documented early graft occlusion (71,72). Nevertheless, owing to considerable overlap of troponin values between patients with and without graft occlusion, troponin levels may not reliably predict graft occlusion in individual patients (71). The most appropriate troponin cutoff values for defining perioperative MI have not clearly been defined.

Several studies have supported a relationship between marked postoperative elevation of CK-MB and subsequent survival (Fig. 7). The relationship between postoperative levels of troponin and clinical outcomes has not been extensively studied. However, a relationship to adverse outcomes does appear to exist. Eigel et al. measured troponin I immediately after bypass surgery in 540 patients and found troponin I release to be a significant predictor of death and reinfarction (95). In another series of 202 patients undergoing CABG, high postoperative troponin I levels were associated with increased risk of cardiac death at 2 yr (73). In 224 patients undergoing cardiac surgery (bypass surgery in 171 patients), a postoperative troponin T level  $\geq 1.58$  ng/mL was an independent predictor of in-hospital complications, including death, shock, and MI (74); a prolonged length of stay in the intensive care unit (75); and mortality at 1 yr (76). This observation is consistent with the findings of other studies documenting the association between high postoperative troponin I or troponin T levels and postoperative short- and long-term morbidity and mortality (Fig. 8) (77–80).



**Fig. 7.** Relationship between postoperative concentration of CK-MB and survival. (Adapted from ref. 8.)



**Fig. 8.** Relationship between postoperative concentration of cardiac troponin and survival after CABG. (Data from ref. 91.)

### CONCLUSION

Measurement of troponin after PCI and CABG is a very sensitive method for detecting myocardial necrosis related to these coronary revascularization procedures. Troponin is frequently elevated after PCI and almost universally elevated after CABG, with marked elevations in 20–40% of CABG cases. A number of procedure-related factors contribute to the rises in troponin, including unrecognized complications of PCI (distal embolization, minor side-branch occlusion), inflammation, direct cardiac manipulation, and direct current defibrillation during CABG. Although troponin levels are helpful in diagnosing peri-procedural myonecrosis as well as predicting long-term outcomes, the optimal diagnostic and prognostic cutoff levels for the different clinical settings and the various troponin assays that are commercially available remain to be determined. Moreover, to date, the appropriate clinical response to these findings remains uncertain.

## REFERENCES

1. Califf RM, Abdelmeguid AE, Kuntz RE, et al. Myonecrosis after revascularization procedures. *J Am Coll Cardiol* 1998;31:241–251.
2. Tardiff BE, Califf RM, Tchong JE, et al. Clinical outcomes after detection of elevated cardiac enzymes in patients undergoing percutaneous intervention. IMPACT-II Investigators. Integrilin (eptifibatide) to Minimize Platelet Aggregation and Coronary Thrombosis-II. *J Am Coll Cardiol* 1999;33:88–96.
3. Abdelmeguid AE, Topol EJ, Whitlow PL, Sapp SK, Ellis SG. Significance of mild transient release of creatine kinase-MB fraction after percutaneous coronary interventions. *Circulation* 1996;94:1528–1536.
4. Kini A, Marmur JD, Kini S, et al. Creatine kinase-MB elevation after coronary intervention correlates with diffuse atherosclerosis, and low-to-medium level elevation has a benign clinical course: implications for early discharge after coronary intervention. *J Am Coll Cardiol* 1999;34:663–671.
5. Saucedo JF, Mehran R, Dangas G, et al. Long-term clinical events following creatine kinase—myocardial band isoenzyme elevation after successful coronary stenting. *J Am Coll Cardiol* 2000;35:1134–1141.
6. Ricciardi MJ, Wu E, Davidson CJ, et al. Visualization of discrete microinfarction after percutaneous coronary intervention associated with mild creatine kinase-MB elevation. *Circulation* 2001;103:2780–2783.
7. Newby LK, Alpert JS, Ohman EM, Thygesen K, Califf RM. Changing the diagnosis of acute myocardial infarction: implications for practice and clinical investigations. *Am Heart J* 2002;144:957–980.
8. Klatte K, Chaitman BR, Theroux P, et al. Increased mortality after coronary artery bypass graft surgery is associated with increased levels of postoperative creatine kinase-myocardial band isoenzyme release: results from the GUARDIAN trial. *J Am Coll Cardiol* 2001;38:1070–1077.
9. Burns RJ, Gladstone PJ, Tremblay PC, et al. Myocardial infarction determined by technetium-99m pyrophosphate single-photon tomography complicating elective coronary artery bypass grafting for angina pectoris. *Am J Cardiol* 1989;63:1429–1434.
10. Mandadi VR, DeVoe MC, Ambrose JA, et al. Predictors of troponin elevation after percutaneous coronary intervention. *Am J Cardiol* 2004;93(6):747–750.
11. Miller WL, Garratt KN, Burritt MF, Reeder GS, Jaffe AS. Timing of peak troponin T and creatine kinase-MB elevations after percutaneous coronary intervention. *Chest* 2004;125(1):275–280.
12. Christenson RH, Duh SH, Apple FS, et al. Standardization of cardiac troponin I assays: round robin of ten candidate reference materials. *Clin Chem* 2001;47:431–437.
13. Bertinchant JP, Polge A, Ledermann B, et al. Relation of minor cardiac troponin I elevation to late cardiac events after uncomplicated elective successful percutaneous transluminal coronary angioplasty for angina pectoris. *Am J Cardiol* 1999;84:51–57.
14. Johansen O, Brekke M, Stromme JH, et al. Myocardial damage during percutaneous transluminal coronary angioplasty as evidenced by troponin T measurements. *Eur Heart J* 1998;19:112–117.
15. Katoh H, Shimada T, Sano K, et al. Troponin T in the coronary sinus and percutaneous transluminal coronary angioplasty related myocardial injury. *Clin Exp Pharmacol Physiol* 2000;27:14–17.
16. Talasz H, Genser N, Mair J, et al. Side-branch occlusion during percutaneous transluminal coronary angioplasty. *Lancet* 1992;339:1380–1382.
17. La Vecchia L, Bedogni F, Finocchi G, et al. Troponin T, troponin I and creatine kinase-MB mass after elective coronary stenting. *Coron Artery Dis* 1996;7:535–540.
18. Natarajan MK, Kreatsoulas C, Velianou JL, Mehta SR, Pericak D, Goodhart DM. Incidence, predictors, and clinical significance of troponin-I elevation without creatine kinase elevation following percutaneous coronary interventions. *Am J Cardiol* 2004;93(6):750–753.
19. Ricciardi MJ, Davidson CJ, Gubernikoff G, et al. Troponin I elevation and cardiac events after percutaneous coronary intervention. *Am Heart J* 2003;145:522–528.
20. Fuchs S, Kornowski R, Mehran R, et al. Prognostic value of cardiac troponin-I levels following catheter-based coronary interventions. *Am J Cardiol* 2000;85:1077–1082.
21. Bolognese L, Ducci K, Angioli P, et al. Elevations in troponin I after percutaneous coronary interventions are associated with abnormal tissue-level perfusion in high-risk patients with non-ST-segment-elevation acute coronary syndromes. *Circulation* 2004;110:1592–1597.
22. Cantor WJ, Newby LK, Christenson RH, et al. Prognostic significance of elevated troponin-I after percutaneous coronary intervention. *J Am Coll Cardiol* 2002;39:1738–1744.
23. La Vecchia L, Bedogni F, Finocchi G, et al. Troponin T, troponin I and CK-MB (mass) in the detection of periprocedural myocardial damage after coronary angioplasty. *Cardiologia* 1997;42:405–413.
24. Shyu KG, Kuan PL, Cheng JJ, Hung CR. Cardiac troponin T, creatine kinase, and its isoform release after successful percutaneous transluminal coronary angioplasty with or without stenting. *Am Heart J* 1998;135:862–867.

25. Segev A, Goldman LE, Cantor WJ, et al. Elevated troponin-I after percutaneous coronary interventions: incidence and risk factors. *Cardiovasc Radiat Med* 2004;5:59–63.
26. Saadeddin SM, Habbab MA, Sobki SH, Ferns GA. Association of systemic inflammatory state with troponin I elevation after elective uncomplicated percutaneous coronary intervention. *Am J Cardiol* 2002; 89(8):981–983.
27. Pasceri V, Patti G, Nusca A, Pristipino C, Richichi G, Di Sciascio G. Randomized trial of atorvastatin for reduction of myocardial damage during coronary intervention: results from the ARMYDA (Atorvastatin for Reduction of MYocardial Damage during Angioplasty) study. *Circulation* 2004;110:674–678.
28. Akkerhuis KM, Alexander JH, Tardiff BE, et al. Minor myocardial damage and prognosis: are spontaneous and percutaneous coronary intervention-related events different? *Circulation* 2002;105:554–556.
29. Kizer JR, Muttref MR, Matthai WH, et al. Role of cardiac troponin T in the long-term risk stratification of patients undergoing percutaneous coronary intervention. *Eur Heart J* 2003;24(14):1314–1322.
30. Gruberg L, Fuchs S, Waksman R, et al. Prognostic value of cardiac troponin I elevation after percutaneous coronary intervention in patients with chronic renal insufficiency: a 12-month outcome analysis [see comment]. *Cathet Cardiovasc Intervent* 2002;55(2):174–179.
31. Saadeddin SM, Habbab MA, Sobki SH, Ferns GA. Minor myocardial injury after elective uncomplicated successful PTCA with or without stenting: detection by cardiac troponins. *Cathet Cardiovasc Intervent* 2001;53:188–192.
32. Genser N, Mair J, Talasz H, et al. Cardiac troponin I to diagnose percutaneous transluminal coronary angioplasty-related myocardial injury. *Clin Chim Acta* 1997;265:207–217.
33. Nageh T, Sherwood RA, Harris BM, Byrne JA, Thomas MR. Cardiac troponin T and I and creatine kinase-MB as markers of myocardial injury and predictors of outcome following percutaneous coronary intervention. *Int J Cardiol* 2003;92:285–293.
34. Stromme JH, Johansen O, Brekke M, Seljeflot I, Arnesen H. Markers of myocardial injury in blood following PTCA: a comparison of CKMB, cardiospecific troponin T and troponin I. *Scand J Clin Lab Invest* 1998;58:693–699.
35. Harris BM, Nageh T, Marsden JT, Thomas MR, Sherwood RA. Comparison of cardiac troponin T and I and CK-MB for the detection of minor myocardial damage during interventional cardiac procedures. *Ann Clin Biochem* 2000;37(Pt 6):764–769.
36. Gustavsson CG, Hansen O, Frennby B. Troponin must be measured before and after PCI to diagnose procedure-related myocardial injury. *Scand Cardiovasc J* 2004;38(2):75–79.
37. Atmaca Y, Gulec S, Ertas F, Pamir G, Oral D. The prevention of minor myocardial injury with ticlopidine pretreatment in patients undergoing elective coronary stenting. *Int J Cardiol* 2003;87(2–3):151–157.
38. Atmaca Y, Dandachi R, Gulec S, Dincer I, Oral D. Comparison of clopidogrel versus ticlopidine for prevention of minor myocardial injury after elective coronary stenting. *Int J Cardiol* 2003;87(2–3):143–149.
39. Cantor WJ, Vandenbroucke A, Strauss BH, et al. Do glycoprotein IIb/IIIa inhibitors interact with assays for myocardial necrosis? *Clin Biochem* 2003;36:663–666.
40. Kini AS, Richard M, Suleman J, et al. Effectiveness of tirofiban, eptifibatide, and abciximab in minimizing myocardial necrosis during percutaneous coronary intervention (TEAM pilot study). *Am J Cardiol* 2002;90(5):526–529.
41. Rupprecht HJ, Terres W, Ozbek C, et al. Recombinant hirudin (HBW 023) prevents troponin T release after coronary angioplasty in patients with unstable angina. *J Am Coll Cardiol* 1995;26:1637–1642.
42. Kurz DJ, Naegeli B, Bertel O. A double-blind, randomized study of the effect of immediate intravenous nitroglycerin on the incidence of postprocedural chest pain and minor myocardial necrosis after elective coronary stenting. *Am Heart J* 2000;139:35–43.
43. Sakai K, Yamagata T, Teragawa H, Matsuura H, Chayama K. Nicorandil-induced preconditioning as evidenced by troponin T measurements after coronary angioplasty in patients with stable angina pectoris. *Jpn Heart J* 2002;43(5):443–453.
44. Baim DS, Wahr D, George B, et al. Randomized trial of a distal embolic protection device during percutaneous intervention of saphenous vein aorto-coronary bypass grafts. *Circulation* 2002;105:1285–1290.
45. Leborgne L, Cheneau E, Pichard A, et al. Effect of direct stenting on clinical outcome in patients treated with percutaneous coronary intervention on saphenous vein graft. *Am Heart J* 2003;146:501–506.
46. Sharma SK, Kini A, Marmur JD, Fuster V. Cardioprotective effect of prior beta-blocker therapy in reducing creatine kinase-MB elevation after coronary intervention: benefit is extended to improvement in intermediate-term survival. *Circulation* 2000;102(2):166–172.
47. Ellis SG, Brener SJ, Lincoff AM, et al. Beta-blockers before percutaneous coronary intervention do not attenuate postprocedural creatine kinase isoenzyme rise. *Circulation* 2001;104(22):2685–2688.

48. Ellis SG, Schneider JP, Topol EJ. Comparison of long-term survival following non-Q-wave creatine kinase elevation after percutaneous coronary intervention in patients discharged on a beta blocker versus those not so treated. *Am J Cardiol* 2002;89(6):751–753.
49. Bonnefoy E, Filley S, Kirkorian G, et al. Troponin I, troponin T, or creatine kinase-MB to detect perioperative myocardial damage after coronary artery bypass surgery. *Chest* 1998;114:482–486.
50. Gensini GF, Fusi C, Conti AA, et al. Cardiac troponin I and Q-wave perioperative myocardial infarction after coronary artery bypass surgery. *Crit Care Med* 1998;26:1986–1990.
51. Jacquet L, Noirhomme P, El Khoury G, et al. Cardiac troponin I as an early marker of myocardial damage after coronary bypass surgery. *Eur J Cardiothorac Surg* 1998;13:378–384.
52. Alyanakian MA, Dehoux M, Chatel D, et al. Cardiac troponin I in diagnosis of perioperative myocardial infarction after cardiac surgery. *J Cardiothorac Vasc Anesth* 1998;12(3):288–294.
53. Etievent JP, Chocron S, Toubin G, et al. Use of cardiac troponin I as a marker of perioperative myocardial ischemia. *Ann Thorac Surg* 1995;59:1192–1194.
54. Horvath KA, Parker MA, Frederiksen JW, Palmer AS, Fullerton DA. Postoperative troponin I values: insult or injury? *Clin Cardiol* 2000;23:731–733.
55. Braun SL, Barankay A, Mazzitelli D. Plasma troponin T and troponin I after minimally invasive coronary bypass surgery. *Clin Chem* 2000;46(2):279–281.
56. Birdi I, Caputo M, Hutter JA, Bryan AJ, Angelini GD. Troponin I release during minimally invasive coronary artery surgery. *J Thorac Cardiovasc Surg* 1997;114:509,510.
57. Krejca M, Skiba J, Szmagala P, Gburek T, Bochenek A. Cardiac troponin T release during coronary surgery using intermittent cross-clamp with fibrillation, on-pump and off-pump beating heart. *Eur J Cardiothorac Surg* 1999;16:337–341.
58. Koh TW, Carr-White GS, DeSouza AC, et al. Intraoperative cardiac troponin T release and lactate metabolism during coronary artery surgery: comparison of beating heart with conventional coronary artery surgery with cardiopulmonary bypass. *Heart* 1999;81:495–500.
59. Kilger E, Pichler B, Weis F, et al. Markers of myocardial ischemia after minimally invasive and conventional coronary operation. *Ann Thorac Surg* 2000;70:2023–2038.
60. Swaanenburg JC, Loef BG, Volmer M, et al. Creatine kinase MB, troponin I, and troponin T release patterns after coronary artery bypass grafting with or without cardiopulmonary bypass and after aortic and mitral valve surgery. *Clin Chem* 2001;47:584–587.
61. Bennetts JS, Baker RA, Ross IK, Knight JL. Assessment of myocardial injury by troponin T in off-pump coronary artery grafting and conventional coronary artery graft surgery [see comment]. *ANZ J Surg* 2002;72(2):105–109.
62. Crescenzi G, Cedrati V, Landoni G, et al. Cardiac biomarker release after CABG with different surgical techniques. *J Cardiothorac Vasc Anesth* 2004;18(1):34–37.
63. Pichon H, Chocron S, Alwan K, et al. Crystalloid versus cold blood cardioplegia and cardiac troponin I release. *Circulation* 1997;96:316–320.
64. Chocron S, Alwan K, Toubin G, et al. Crystalloid cardioplegia route of delivery and cardiac troponin I release. *Ann Thorac Surg* 1996;62:4801–485.
65. Caputo M, Dihmis W, Birdi I, et al. Cardiac troponin T and troponin I release during coronary artery surgery using cold crystalloid and cold blood cardioplegia. *Eur J Cardiothorac Surg* 1997;12:254–260.
66. Benoit MO, Paris M, Silleran J, Fiemeyer A, Moatti N. Cardiac troponin I: its contribution to the diagnosis of perioperative myocardial infarction and various complications of cardiac surgery. *Crit Care Med* 2001;29:1880–1886.
67. Carrier M, Pellerin M, Perrault LP, Solymoss BC, Pelletier LC. Troponin levels in patients with myocardial infarction after coronary artery bypass grafting. *Ann Thorac Surg* 2000;69(2):435–440.
68. Mair J, Larue C, Mair P, Balogh D, Calzolari C, Puschendorf B. Use of cardiac troponin I to diagnose perioperative myocardial infarction in coronary artery bypass grafting. *Clin Chem* 1994;40:2066–2070.
69. Sadony V, Korber M, Albes G, et al. Cardiac troponin I plasma levels for diagnosis and quantitation of perioperative myocardial damage in patients undergoing coronary artery bypass surgery [see comment]. *Eur J Cardio-Thorac Surg* 1998;13:57–65.
70. Fransen EJ, Diris JH, Maessen JG, Hermens WT, Diejjen-Visser MP. Evaluation of “new” cardiac markers for ruling out myocardial infarction after coronary artery bypass grafting. *Chest* 2002;122(4):1316–1321.
71. Holmvang L, Jurlander B, Rasmussen C, Thiis JJ, Grande P, Clemmensen P. Use of biochemical markers of infarction for diagnosing perioperative myocardial infarction and early graft occlusion after coronary artery bypass surgery. *Chest* 2002;121(1):103–111.



72. Thielmann M, Massoudy P, Marggraf G, et al. Role of troponin I, myoglobin, and creatine kinase for the detection of early graft failure following coronary artery bypass grafting. *Eur J Cardio-Thorac Surg* 2004;26:102–109.
73. Fellahi JL, Gue X, Richomme X, Monier E, Guillou L, Riou B. Short- and long-term prognostic value of postoperative cardiac troponin I concentration in patients undergoing coronary artery bypass grafting. *Anesthesiology* 2003;99(2):270–274.
74. Januzzi JL, Lewandowski K, MacGillivray TE, et al. A comparison of cardiac troponin T and creatine kinase-MB for patient evaluation after cardiac surgery. *J Am Coll Cardiol* 2002;39:1518–1523.
75. Baggish AL, MacGillivray TE, Hoffman W, et al. Postoperative troponin-T predicts prolonged intensive care unit length of stay following cardiac surgery. *Crit Care Med* 2004;32:1866–1871.
76. Kathiresan S, Servoss SJ, Newell JB, et al. Cardiac troponin T elevation after coronary artery bypass grafting is associated with increased one-year mortality. *Am J Cardiol* 2004;94:879–881.
77. Lasocki S, Provenchere S, Benessiano J, et al. Cardiac troponin I is an independent predictor of in-hospital death after adult cardiac surgery. *Anesthesiology* 2002;97(2):405–411.
78. Lehrke S, Steen H, Sievers HH, et al. Cardiac troponin T for prediction of short- and long-term morbidity and mortality after elective open heart surgery. *Clin Chem* 2004;50(9):1560–1567.
79. Lyon WJ, Baker RA, Andrew MJ, Tirimacco R, White GH, Knight JL. Relationship between elevated preoperative troponin T and adverse outcomes following cardiac surgery. *ANZ J Surg* 2003;73:40–44.
80. Greenson N, Macoviak J, Krishnaswamy P, et al. Usefulness of cardiac troponin I in patients undergoing open heart surgery. *Am Heart J* 2001;141:447–455.
81. Attali P, Aleil B, Petitpas G, et al. Sensitivity and long-term prognostic value of cardiac troponin-I increase shortly after percutaneous transluminal coronary angioplasty. *Clin Cardiol* 1998;21:353–356.
82. Bonz AW, Lengenfelder B, Strotmann J, et al. Effect of additional temporary glycoprotein IIb/IIIa receptor inhibition on troponin release in elective percutaneous coronary interventions after pretreatment with aspirin and clopidogrel (TOPSTAR trial). *J Am Coll Cardiol* 2002;40(4):662–668.
83. Garbarz E, Iung B, Lefevre G, et al. Frequency and prognostic value of cardiac troponin I elevation after coronary stenting. *Am J Cardiol* 1999;84:515–518.
84. Herrmann J, Von Birgelen C, Haude M, et al. Prognostic implication of cardiac troponin T increase following stent implantation. *Heart* 2002;87:549–553.
85. Hunt AC, Chow SL, Shiu MF, Chilton DC, Cummins B, Cummins P. Release of creatine kinase-MB and cardiac specific troponin-I following percutaneous transluminal coronary angioplasty. *Eur Heart J* 1991;12:690–693.
86. Karim MA, Shinn MS, Oskarsson H, Windle J, Deligonul U. Significance of cardiac troponin T release after percutaneous transluminal coronary angioplasty. *Am J Cardiol* 1995;76:521–523.
87. Kini AS, Lee P, Marmur JD, et al. Correlation of postpercutaneous coronary intervention creatine kinase-MB and troponin I elevation in predicting mid-term mortality. *Am J Cardiol* 2004;93:18–23.
88. Ravkilde J, Nissen H, Mickley H, Andersen PE, Thayssen P, Horder M. Cardiac troponin T and CK-MB mass release after visually successful percutaneous transluminal coronary angioplasty in stable angina pectoris. *Am Heart J* 1994;127:13–20.
89. Reimers B, Lachin M, Cacciavillani L, et al. Troponin T, creatine kinase MB mass, and creatine kinase MB isoform ratio in the detection of myocardial damage during non-surgical coronary revascularization. *Int J Cardiol* 1997;60:7–13.
90. Ricchiuti V, Shear WS, Henry TD, Paulsen PR, Miller EA, Apple FS. Monitoring plasma cardiac troponin I for the detection of myocardial injury after percutaneous transluminal coronary angioplasty. *Clin Chim Acta* 2000;302:161–170.
91. Saadeddin SM, Habbab MA, Sobki SH, Ferns GA. Biochemical detection of minor myocardial injury after elective, uncomplicated, successful percutaneous coronary intervention in patients with stable angina: clinical outcome. *Ann Clin Biochem* 2002;39(Pt 4):392–397.
92. Sribhen K, Leowattana W, Kiartivich S, Jotnar P. Cardiac troponin T concentration after coronary balloon angioplasty. *Am J Cardiol* 1997;79:1439.
93. Wu AH, Boden WE, McKay RG. Long-term follow-up of patients with increased cardiac troponin concentrations following percutaneous coronary intervention. *Am J Cardiol* 2002;89:1300–1302.
94. Selvanayagam JB, Porto I, Channon K, et al. Troponin elevation after percutaneous coronary intervention directly represents the extent of irreversible myocardial injury: insights from cardiovascular magnetic resonance imaging. *Circulation* 2005;111:1027–1032.
95. Eigel P, van Ingen G, Wagenpfeil S. Predictive value of perioperative cardiac troponin I for adverse outcome in coronary artery bypass surgery. *Eur J Cardiothorac Surg* 2001;20:544–549.

# 8

---

## Biomarkers of Necrosis in Heart Failure

*Past, Present, and Future Directions*

---

*Emil Missov, MD, PhD,*

*James Rider, MD, and Leslie Miller, MD*

### CONTENTS

INTRODUCTION

DETECTION OF CARDIAC TROPONIN IN CHF

COMBINED MEASUREMENT OF TROPONIN AND NATRIURETIC PEPTIDES

FUTURE DIRECTIONS

CONCLUSION

REFERENCES

---

### SUMMARY

Cardiac troponin I (cTnI) and cardiac troponin T (cTnT) are highly specific and sensitive biomarkers of necrosis. Although they are used primarily for the diagnosis of acute coronary syndromes, their application to the field of congestive heart failure (CHF) has now received significant interest. cTnI and cTnT provide valuable clinical information not available through other diagnostic methods and improve the laboratory characterization of CHF. They also allow accurate risk stratification and prognosis. An important aspect of their clinical use is the monitoring of therapeutic interventions in patients with heart failure. The inclusion of cardiac troponins in a multimarker strategy and the development of more sensitive immunoassays will likely further contribute to their acceptance as clinical tools in CHF.

**Key Words:** Cardiac troponin I; cardiac troponin T; heart failure.

### INTRODUCTION

This chapter reviews the physiological rationale and clinical use of cardiac troponins as biomarkers of necrosis in congestive heart failure (CHF). CHF is characterized by left ventricular (LV) systolic dysfunction, which includes decreased cardiac output, increased wall stress, LV dilatation, and remodeling. Changes in relaxation, compliance, and stiffness of the myocardium, generally referred to as LV diastolic dysfunction, further contribute to the clinical presentation. At the cellular level, CHF is characterized by a general process

From: *Contemporary Cardiology:  
Cardiovascular Biomarkers: Pathophysiology and Disease Management*  
Edited by: David A. Morrow © Humana Press Inc., Totowa, NJ

of adaptive phenotypic changes. These include cell elongation and hypertrophy, altered expression of cytoskeletal proteins, and changes in energy metabolism (1). The hypertrophic response shortens cell survival through increased energy utilization, decreased removal of calcium from the cytosol, and calcium overload, which ultimately leads to cardiac cell death (2).

Cardiac remodeling and cell death comprise the structural basis of CHF. Cardiac cell death occurs through two primary mechanisms: apoptosis and necrosis. Apoptosis is a tightly regulated sequence of cellular events resulting in loss of viable myocytes without an inflammatory reaction. Apoptosis is triggered by damage to DNA, cell membrane components, and mitochondria (3,4). This process is mediated by molecular signals involving cytokine and nuclear receptors. The second mechanism of cell death is cardiac cell necrosis. It involves membrane damage, cell swelling, and significant local inflammation followed by fibrosis. Cell necrosis is triggered by ischemia, increased wall stress, neurohumoral factors, free radicals, and calcium overload. Additional structural changes occur in the nonmyocyte compartment, which includes extracellular matrix and fibroblasts. These changes lead to myocardial fibrosis and further contribute to LV systolic and diastolic dysfunction.

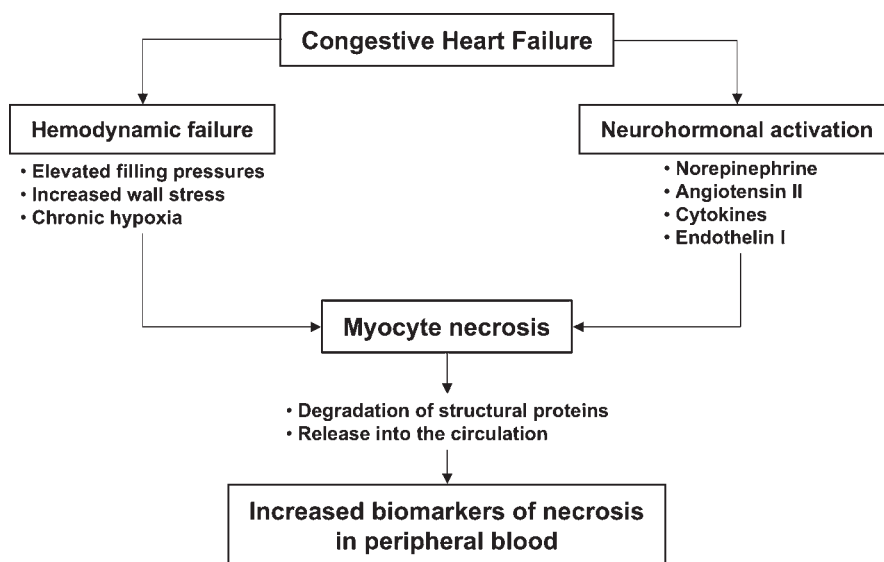
Troponin I and T are structural proteins with isoforms that are expressed uniquely in the adult human heart. Because of their unique intracellular localization and the availability of highly specific immunoassays for their detection, both cardiac troponin I (cTnI) and cardiac troponin (cTnT) have become the standard of care for the biochemical diagnosis of acute coronary syndromes (5–8). These highly sensitive and specific biomarkers of myocyte necrosis have now revealed myocardial injury in a variety of clinical settings, including patients with CHF.

## DETECTION OF CARDIAC TROPONIN IN CHF

Different neurohumoral markers, including norepinephrine, angiotensin II, plasma renin, endothelin 1, cytokines, A-type natriuretic peptide, and B-type natriuretic peptide (BNP), have been used in the research and/or clinical evaluation of heart failure. However, these biomarkers lack cardiac specificity and only indicate neurohumoral activation and/or hemodynamic failure. Historically, there have been no structural biomarkers of heart failure.

### *Frequency and Clinical Correlates*

Figure 1 represents the pathophysiological concept that CHF is characterized by a chronic low level of myocardial injury leading to degradation of structurally bound proteins, including cardiac troponin (9). The concept of measuring cardiac troponin in patients with CHF was introduced in 1995. In a pilot study, Missov et al. measured cTnI in 11 end-stage heart failure patients and in 11 control subjects (10). They found that 2 of 11 patients with CHF had levels of cTnI above the upper reference limit of the assay (0.1 ng/mL), whereas an increased concentration of troponin was not detectable in any of the control subjects. In a follow-up study, the same investigators used a more sensitive immunoassay to measure cTnI (11). This assay had a lower limit of detection, 3 pg/mL, and no cross-reactivity with the skeletal muscle isoform of troponin I. The results showed that the mean concentration of cTnI was  $72.1 \pm 15.8$  pg/mL in stable ambulatory patients with New York Heart Association (NYHA) class III or IV heart failure, compared with  $36.5 \pm 5.5$  pg/mL in hospitalized patients without cardiac disease, and  $20.4 \pm 3.2$  pg/mL in



**Fig. 1.** Possible pathophysiological pathway for release of biomarkers of necrosis in patients with CHF. (From ref. 9.)

healthy blood donors ( $p < 0.01$  for each vs heart failure patients) (Fig. 2A). Although lacking the high specificity of cardiac troponin for myocardial damage, measurements of cardiac-specific isofocus of creatine kinase (CK-MB) and myoglobin, two additional biomarkers of necrosis, produced similar results (Fig. 2B,C). These data provided the first evidence for ongoing myocyte injury and an increased concentration of cardiac troponin in the peripheral blood of patients with advanced heart failure and showed the potential usefulness of cardiac troponin as a specific and sensitive biomarker in severe CHF.

These findings have subsequently been validated in multiple clinical studies. In a study of a similar population of patients with heart failure and matched control subjects (12), heart failure patients had significantly elevated levels of cTnT (Table 1), with the concentration of cTnT correlating inversely with LV ejection fraction (LVEF). These data confirmed that sensitive biomarkers of necrosis are increased in patients with CHF and parallel the severity of the disease. Logeart et al. (13) also documented ongoing cardiac cell injury using cTnI in 71 patients with nonischemic cardiomyopathy and NYHA Class II–IV heart failure. In their study, heart failure patients with elevated cTnI were more likely to have echocardiographic findings of a concentric remodeling pattern and evidence of diastolic dysfunction. Others have shown that patients with advanced CHF and detectable levels of cTnI have significantly more impaired hemodynamic profiles, including higher pulmonary capillary wedge pressure and lower cardiac index (14).

### ***Relationship to Clinical Outcomes***

La Vecchia et al. (15) investigated the clinical usefulness of cTnI as a diagnostic and prognostic marker in patients with severe heart failure. They enrolled 34 patients with NYHA functional class II–IV CHF and stratified them into two groups based on the presence or absence of detectable cTnI. The study showed that detectable levels of cTnI identified a high-risk subgroup of patients ( $n = 10$ ; 29%) with increased short-term mortality (hazard ratio: 6.86; 95% confidence interval [CI]: 1.32–35.4). Furthermore, LVEF was significantly lower in patients with elevated cTnI compared with patients with undetect-

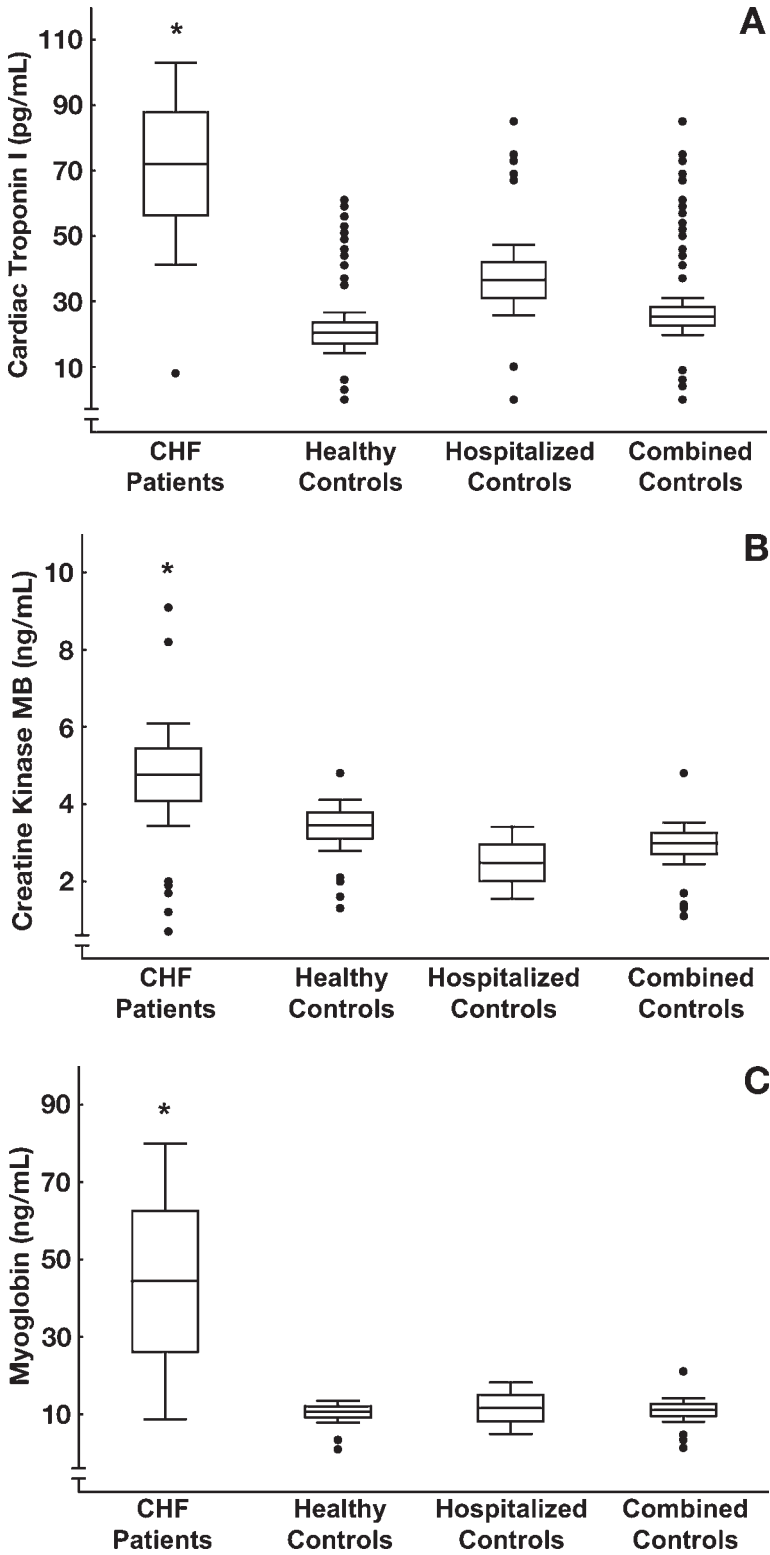


Fig. 2.

Table 1  
cTnT and CK-MB in Patients with CHF

	CHF (n = 33)	CTL (n = 47) <sup>a</sup>	p Value
cTnT (ng/mL)	0.140 ± 0.439	0.0002 ± 0.001	0.0001
CK-MB (ng/mL)	3.76 ± 3.65	2.62 ± 2.16	0.0474

<sup>a</sup>CTL, healthy control subjects. (From ref. 11.)

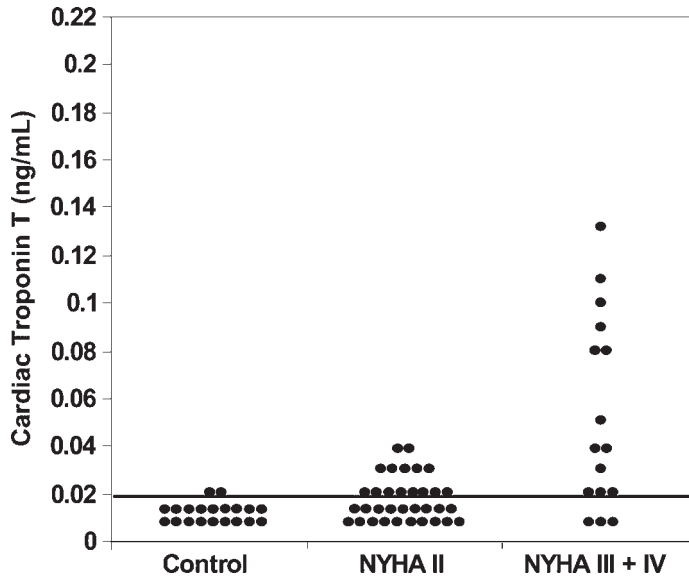
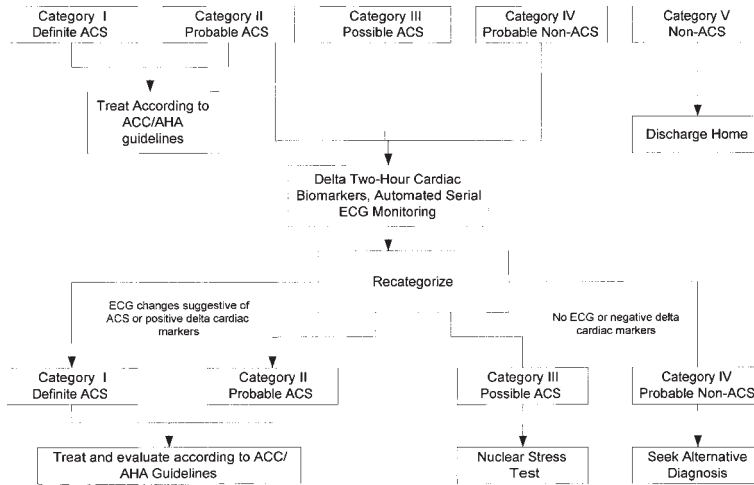


Fig. 3. The concentration of cTnT correlates with the severity of CHF. (From ref. 16.)

able levels ( $20 \pm 5$  vs  $26 \pm 7\%$ ;  $p = 0.023$ ) with a trend toward higher intracardiac pressures. Notably, there was no histological evidence of myocarditis in those patients with elevated cTnI, and the cause of CHF was evenly distributed among ischemic and nonischemic etiologies.

The important observation that cardiac troponin is associated with outcome as well as severity of disease in patients with CHF has been corroborated by several studies. In a study of 56 consecutive patients with chronic heart failure from a variety of etiologies, Setsuta et al. (16) showed that levels of cTnT correlated with the severity of heart failure as determined by NYHA functional class (Fig. 3). In addition, a concentration of cTnT  $>0.02$  ng/mL was associated with a significantly higher risk of death or readmission for worsening heart failure (Fig. 4). Similarly, in a prospective study of 84 patients with acute cardiogenic pulmonary edema without myocardial infarction, Perna et al. (17) found that cTnT  $>0.1$  ng/mL measured in samples obtained 6 and 12 h after admission was strongly associated with lower 3-yr survival (29 vs 76% in patients with elevated vs normal cTnT results,

**Fig. 2.** (Opposite page) Box and whisker plots of serum concentrations of cTnI, CK-MB, and myoglobin in patients with CHF ( $n = 35$ ), healthy control subjects ( $n = 55$ ), hospitalized control subjects without cardiovascular disease ( $n = 25$ ), and both control groups ( $n = 80$ ). The line within the box is the mean value, the upper and lower box values represent  $\pm 1$  times the SE, the whiskers in the plot are defined as the mean  $\pm 1.96$  times the SE, and the closed circles are individual data points exceeding this specified value. (A)  $*p < 0.01$  vs all groups; (B)  $*p < 0.01$  vs hospitalized control subjects and combined control subjects; (C)  $*p < 0.01$  vs all groups. (From ref. 11.)



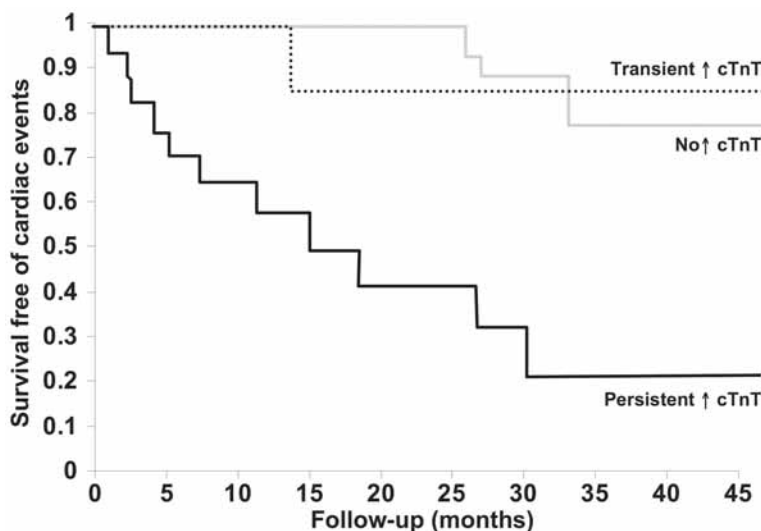
**Fig. 4.** Survival free of cardiac events (death or rehospitalization) for heart failure among patients with CHF stratified by cTnT at hospitalization. (From ref. 16.)

log-rank test;  $p < 0.001$ ). In the largest of these studies, Horwich et al. (14) evaluated 238 patients with advanced heart failure referred for cardiac transplantation who had cTnI measured at the time of initial presentation. A significant correlation was also found between the baseline concentration of cTnI and the progressive decline in LVEF over time. Moreover, by virtue of the larger sample size, this study revealed that cTnI was associated with increased mortality independently of the patient's age, cause of CHF, and LV function (adjusted relative risk [RR]: 1.85; 95% CI: 1.04–3.26). Other important findings of the study were that the optimal cutpoint identified by receiver operator curve analysis was at the lower reference limit for the assay used, and that higher levels of cTnI were not associated with additional risk. In other words, any detectable elevation in cTnI conferred a similar level of increased risk. The fact that any positive cTnI result rather than the absolute value of the result carried an increased risk has important clinical implications and makes the finding of the study applicable to laboratories using different immunoassays to measure troponin.

More important, the prognostic relationship between cardiac troponin and outcome is apparent in stable ambulatory patients with heart failure and is independent of the most commonly used NYHA functional classification. Hudson et al. (18) collected prospective data from NYHA functional class II–IV heart failure patients with a LVEF of  $\leq 35\%$ . The end points of the study were death or hospitalization for heart failure. Of 136 patients, 33 (24%) had a level of cTnT  $> 0.02$  ng/mL. An elevated level of cTnT was associated with increased risk of death or hospitalization for heart failure (RR: 2.7; 95% CI: 1.7–4.3;  $p = 0.001$ ) and death alone (RR: 4.2; 95% CI: 1.8–9.5;  $p = 0.001$ ) during follow-up. Troponin T and NYHA functional class were both independent predictors of death or heart failure hospitalization in this study. The investigators concluded that approximately one-fourth of ambulatory patients with chronic heart failure had ongoing myocardial necrosis, as shown by abnormal troponin values, which were associated with increased mortality and morbidity.

### *Changes During Therapy*

Goto et al. (19) assessed the clinical value of quantifying serum concentrations of cTnT both in the initial evaluation and in assessing the response to treatment in patients with



**Fig. 5.** Prognostic implications of persistent increases in concentration of cTnT in patients with heart failure. In a study of 60 patients with idiopathic dilated cardiomyopathy, 33 patients had a cTnT  $<0.02$  ng/mL at baseline and throughout follow-up (No  $\uparrow$ ), 10 had a level of cTnT that was increased at baseline and fell during follow-up (Transient  $\uparrow$ ), whereas 17 had persistently elevated levels. (From ref. 20.)

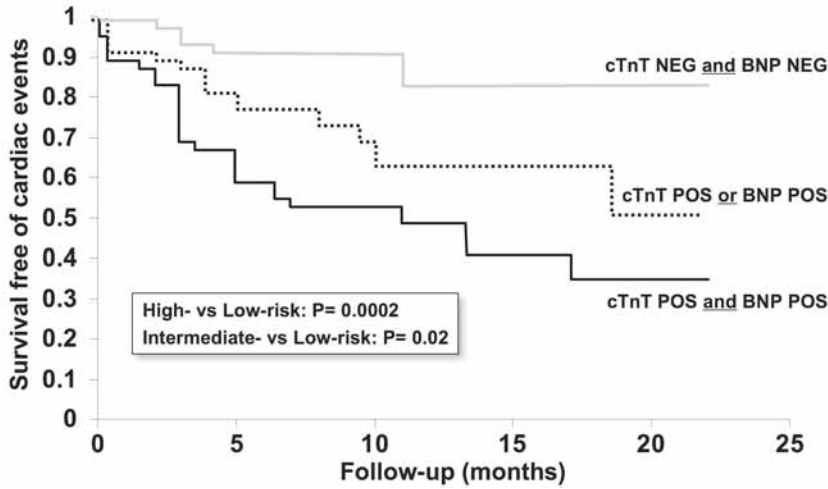
acutely decompensated heart failure. All patients in the study were determined to have a dilated, nonischemic cardiomyopathy. Measurements of cTnT were made at the time of admission and then repeated after stabilization of clinical signs and symptoms, an average of 52 d later. After successful intensive medical therapy, the serum concentration of cTnT was significantly decreased, from  $30 \pm 21$  to  $9 \pm 1$  ng/L ( $p < 0.001$ ).

Sato et al. (20) investigated the clinical significance of persistently elevated cTnT levels in heart failure patients. In a study of 60 patients with idiopathic dilated cardiomyopathy confirmed by coronary angiography and endomyocardial biopsy, patients were categorized into three groups based on measurement of cTnT at baseline and follow-up. In the first group of 33 patients, levels of cTnT were consistently lower than  $0.02$  ng/mL at baseline and throughout follow-up. The remaining patients had an initial concentration of cTnT  $>0.02$  ng/mL. Of these patients, 10 showed decreasing levels during follow-up while the remaining 17 had consistently elevated levels of cTnT. Echocardiographic assessment showed that LV end-diastolic dimension and LVEF improved both in patients with low baseline levels of cTnT and in those in whom initially elevated levels decreased during follow-up. By contrast, among patients with persistently elevated levels of cTnT, LV end-diastolic dimension and LVEF failed to improve during the follow-up period. Moreover, patients with persistently elevated cTnT had significantly lower event-free survival (Fig. 5).

### COMBINED MEASUREMENT OF TROPONIN AND NATRIURETIC PEPTIDES

Natriuretic peptides are established markers of disease severity and prognosis in patients with CHF. Because they reflect ventricular wall stress rather than myocardial injury, it is plausible that natriuretic peptides and cardiac troponin may offer complementary information in this population. Ishii et al. (21) studied 98 consecutive patients hospitalized with worsening heart failure in whom the combined measurement of cTnT and BNP allowed





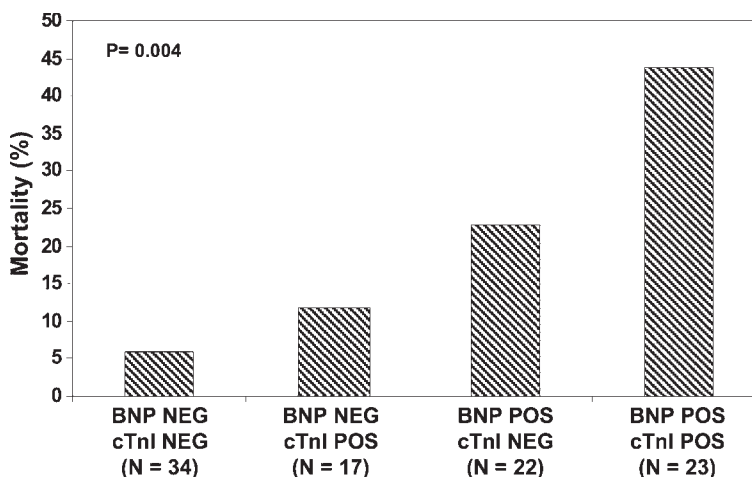
**Fig. 6.** Kaplan-Meier analysis of cardiac event-free survival in patients with CHF stratified into low-, intermediate-, and high-risk groups based on combination of cTnT and BNP. Low-risk group ( $n = 31$ ): cTnT  $\leq 0.033$   $\mu\text{g/L}$  and BNP  $\leq 440$  pg/mL; intermediate-risk group ( $n = 38$ ): cTnT  $> 0.033$   $\mu\text{g/L}$  or BNP  $> 440$  pg/mL; and high-risk group ( $n = 29$ ): cTnT  $> 0.033$   $\mu\text{g/L}$  and BNP  $> 440$  pg/mL. (From ref. 21.)

classification into groups with neither, one, or both biomarker results positive. The concentrations of BNP and cTnT were modestly correlated ( $r = 0.20$ ;  $p = 0.049$ ). Using cut-points of 440 pg/mL for BNP and 0.33  $\mu\text{g/L}$  for cTnT, 38 patients (39%) had one elevated biomarker and in 29 patients (30%) both were elevated. BNP ( $p = 0.03$ ) and cTnT ( $p = 0.016$ ) were both independent predictors of cardiac death during an average follow-up of 451 d. When applied together, these biomarkers revealed a graded relationship with the risk of cardiac death both in hospital (3, 11, and 31% in the low-, intermediate-, and high-risk groups, respectively;  $p = 0.006$ ) and during long-term follow-up (Fig. 6). These observations are supported by similar data from at least one other study in which BNP and cTnI offered complementary information for risk stratification of patients with advanced heart failure (Fig. 7).

## FUTURE DIRECTIONS

Cardiac troponin is likely to become a recognized tool for the laboratory characterization of heart failure, for risk assessment and prognosis, and for monitoring of the efficacy of therapeutic interventions. These goals will be met through the integration of cardiac troponins in a multimarker strategy and through the development of new-generation highly sensitive immunoassays.

A multimarker diagnostic approach in heart failure patients has been suggested (9,11). In a pilot study using the combined approach of measuring cTnI and cTnT in the same population of heart failure patients, Missov and colleagues reported that of 22 patients, 9 (41% of the study population) had undetectable cTnI and cTnT and five (23%) had both cTnI and cTnT above the upper limit of normal. In four patients (18%) only cTnT was elevated, whereas four other patients (18%) had only elevated cTnI (E. Missov, personal communication, 11 Jul 2000, 7th World Congress on Heart Failure, Vancouver, B.C., Canada). These pilot data highlighted the feasibility of biochemical stratification and risk profiling of patients with heart failure by using a combination of cTnI and cTnT. The use of a cardiac



**Fig. 7.** Risk of death in patients with CHF stratified by cTnI and BNP results. (From ref. 14.)

marker of necrosis in combination with a biomarker of hemodynamic stress was described in the previous section. The concept of a multimarker approach in heart failure is likely to guide future research and clinical applications.

The level of any marker protein in the circulation depends on the analytic performance of the assay used for its detection. Initial studies on cardiac troponins in heart failure documented that both cTnI and cTnT could be measured with currently available immunoassays and, in some patients, revealed a magnitude of increase that was similar to that observed in acute myocardial infarction (11,12,15,20). Moreover, the development of a more sensitive immunoassay allowed the detection of cTnI in a greater number of patients. These observations suggest that improved analytic performance will lead to better clinical characterization of the disease process in patients with CHF (11) and support the value of ongoing work focused on the development and clinical validation of more sensitive assays for troponin. Finally, before biomarkers of necrosis are applied routinely in the evaluation of patients with heart failure, prospective studies defining the appropriate therapeutic response are necessary. On the basis of presently available data, it is reasonable to consider more aggressive treatment strategies in line with their higher risk for patients with increased levels of cardiac troponin.

## CONCLUSION

cTnI and cTnT are highly specific and sensitive biomarkers of necrosis. They are easily measured in peripheral blood samples, provide clinical information not available through other diagnostic methods, and improve the laboratory characterization of CHF. Biomarkers of necrosis appear to enhance risk stratification of heart failure patients and may be useful for monitoring the efficacy of therapeutic interventions. As in other clinical settings, multimarker strategies are likely to provide valuable information for therapeutic decision making in patients with heart failure.

## REFERENCES

1. Swynghedauw B. Developmental and functional adaptation of contractile proteins in cardiac and skeletal muscles. *Physiol Rev* 1986;66:710–771.

2. Scott J. Pathophysiology and biochemistry of cardiovascular disease. *Curr Opin Genet Dev* 2004;14:271–279.
3. Narula J, Haider N, Virmani R, et al. Apoptosis in myocytes in end-stage heart failure. *N Engl J Med* 1996;335:1182–1189.
4. Guerra S, Leri A, Wang X, et al. Myocyte death in the failing human heart is gender dependent. *Circ Res* 1999;85:856–866.
5. Adams J, Bodor G, Davila-Roman V, et al. Cardiac troponin I: a marker with high specificity for cardiac injury. *Circulation* 1993;88:101–106.
6. Wagner I, Mair J, Fridrich L, et al. Cardiac troponin T release in acute myocardial infarction is associated with scintigraphic estimates of myocardial scar. *Coron Artery Dis* 1993;4:537–544.
7. Mair J, Genser N, Morandell D, et al. Cardiac troponin I in the diagnosis of myocardial injury and infarction. *Clin Chim Acta* 1996;245:19–38.
8. Tucker J, Collins R, Anderson A, Hauser J, Kalas J, Apple F. Early diagnostic efficiency of cardiac troponin I and troponin T for acute myocardial infarction. *Acad Emerg Med* 1997;4:13–21.
9. Missov E, De Marco T. Clinical insights on the use of highly sensitive cardiac troponin assays. *Clin Chim Acta* 1999;284:175–185.
10. Missov E, Calzolari C. Elevated cardiac troponin I in same patients with severe congestive heart failure. *J Mol Cell Cardiol* 1995;27:A405 (Abstract).
11. Missov E, Calzolari C, Pau B. Circulating cardiac troponin I in severe congestive heart failure. *Circulation* 1997;96:2953–2958.
12. Missov E, Mair J. A novel biochemical approach to congestive heart failure: cardiac troponin T. *Am Heart J* 1999;138:95–99.
13. Logeart D, Beyne P, Cusson C, et al. Evidence of cardiac myolysis in severe nonischemic heart failure and the potential role of increased wall strain. *Am Heart J* 2001;141:247–253.
14. Horwich T, Patel J, MacLellan W, Fonarow G. Cardiac troponin I is associated with impaired hemodynamics, progressive left ventricular dysfunction, and increased mortality rates in advanced heart failure. *Circulation* 2003;108:833–838.
15. La Vecchia L, Mezzena G, Zanolla L, et al. Cardiac troponin I as diagnostic and prognostic marker in severe heart failure. *J Heart Lung Transplant* 2000;19:644–652.
16. Setsuta K, Seino Y, Ogawa T, Arao M, Miyatake Y, Takano T. Use of cytosolic and myofibril markers in the detection of ongoing myocardial damage in patients with chronic heart failure. *Am J Med* 2002;113:717–722.
17. Perna E, Macin S, Parras J, et al. Cardiac troponin T levels are associated with poor short- and long-term prognosis in patients with acute cardiogenic pulmonary edema. *Am Heart J* 2002;143:814–820.
18. Hudson M, O'Connor C, Gattis W, et al. Implications of elevated cardiac troponin T in ambulatory patients with heart failure: a prospective analysis. *Am Heart J* 2004;147:546–552.
19. Goto T, Takase H, Toriyama T, et al. Circulating concentrations of cardiac proteins indicate the severity of congestive heart failure. *Heart* 2003;89:1303–1307.
20. Sato Y, Yamada T, Taniguchi R, et al. Persistently increased serum concentrations of cardiac troponin T in patients with idiopathic dilated cardiomyopathy are predictive of adverse outcomes. *Circulation* 2001;103:369–374.
21. Ishii J, Nomura M, Nakamura Y, et al. Risk stratification using a combination of cardiac troponin T and brain natriuretic peptide in patients hospitalized for worsening chronic heart failure. *Am J Cardiol* 2002;89:691–695.

# 9

---

## Is There a Role for Cardiac Troponin and Other Biomarkers in Patients With Pulmonary Embolism?

---

*Samuel Z. Goldhaber, MD*

### CONTENTS

INTRODUCTION  
RISK STRATIFICATION OF PATIENTS WITH PE  
CARDIAC BIOMARKERS  
CONCLUSION  
REFERENCES

---

### SUMMARY

Acute pulmonary embolism (PE) presents with a wide clinical spectrum of acuity. Patients with anatomically small PE and no underlying cardiopulmonary disease have an excellent prognosis. Massive PE with cardiogenic shock is life-threatening, with a high mortality rate. However, most patients with PE have clinical presentations that are at neither of these extremes. These patients constitute the majority of patients with PE. They require rapid assessment of prognosis in order to optimize therapy. These patients will benefit from early and accurate risk stratification. Biomarkers of necrosis (troponin) and hemodynamic stress (B-type natriuretic peptide) have both proven useful for assessing prognosis in patients with PE. Right ventricular microinfarction and right ventricular shear stress are the most likely explanations for the rise in troponin and natriuretic peptides, respectively. Although these biomarkers do not offer incremental prognostic information in patients who present with cardiogenic shock owing to PE, they may be useful in guiding additional testing and the aggressiveness of therapy. Future investigation will assess these biomarkers in formal prospective management trials.

**Key Words:** Troponin; pulmonary embolism; prognosis; fibrinolysis.

### INTRODUCTION

Acute pulmonary embolism (PE) presents with a wide clinical spectrum of acuity. Patients with anatomically small PE and no underlying cardiopulmonary disease have an excellent prognosis. Massive PE with cardiogenic shock is life-threatening, with a high

From: *Contemporary Cardiology:  
Cardiovascular Biomarkers: Pathophysiology and Disease Management*  
Edited by: David A. Morrow © Humana Press Inc., Totowa, NJ

Table 1  
Rationale for Risk Stratification

<i>Low risk<sup>a</sup></i>	<i>High-risk<sup>a</sup></i>
Low-risk patients can be managed safely with anticoagulation alone, possibly with reduced hospital length of stay.	High-risk patients will benefit from intervention that considers thrombolysis or embolectomy, in addition to anticoagulation.

<sup>a</sup>Clinical evaluation alone cannot necessarily determine which patients are low risk or at high risk.

mortality rate. However, most patients with PE have clinical presentations that are at neither of these extremes. These patients constitute the majority of patients with PE. They require rapid assessment of prognosis in order to optimize therapy and will benefit from early and accurate risk stratification.

## RISK STRATIFICATION OF PATIENTS WITH PE

### *Traditional Approach*

If risk stratification is successful, resources can be allocated rationally and management plans will yield effective and safe outcomes (Table 1). The classic approach to risk stratification of PE relied primarily on measuring systemic arterial pressure. Patients with systolic blood pressure that fell below 90 mmHg were started on iv vasoconstrictors and/or inotropic agents. If such agents failed to raise the systolic blood pressure above 90 mmHg, these individuals were considered high risk.

This crude approach was too restrictive for identifying and detecting the majority of patients at high risk. Younger patients with PE usually have excellent underlying cardiopulmonary function. This enables them to maintain systemic arterial pressure above 90 mmHg until their embolism is nearly fatal. By contrast, patients with medical comorbidities may rapidly develop multisystem organ failure in the setting of massive or submassive PE. By the time they fit the strict classic criterion of “hypotension despite pressors” and are deemed to be at “high risk,” their decompensated cardiac, pulmonary, renal, or hepatic function often precludes a successful outcome.

### *Contemporary Tools*

Contemporary risk stratification combines clinical findings with the results of standard emergency tests such as electrocardiography and chest X-ray, as well as more sophisticated imaging tests. Cardiac biomarkers are the most recent addition to our array of modalities to risk stratify and prognosticate (Table 2).

Formal risk assessment can incorporate a clinical scoring system (1). For example, the Geneva Prognostic Index (1) utilizes an eight-point scoring system and identifies six predictors of adverse outcome: two points each for cancer and hypotension, and one point each for heart failure, prior deep vein thrombosis (DVT), arterial hypoxemia, and ultrasound-proven DVT. As points accumulate, prognosis worsens.

Physical examination, electrocardiogram (ECG), chest X-ray, computed tomography (CT) scan, and echocardiogram can provide evidence of right ventricular (RV) dysfunction, a key prognostic marker of high risk and increased likelihood of suffering major adverse clinical events. On physical examination, tachycardia and tachypnea may suggest high risk. Clues to right heart failure include distended jugular veins, an accentuated pulmonic heart sound, and a tricuspid regurgitation murmur (2).

**Table 2**  
**Methods of Risk Stratification**

---

Clinical evaluation
Gestalt
Formal prognostic indexing
ECG
Echocardiography
RV dilatation
RV function
Chest CT scan
Reconstructed cardiac views
RV enlargement
Cardiac biomarkers
Troponin
Natriuretic peptides

---

**Table 3**  
**Possible Management Strategies for Low-Risk Patients**

- 
1. Intravenous unfractionated heparin as a bridge to oral anticoagulation, usually with warfarin
  2. Low-molecular-weight heparin, as a bridge to oral anticoagulation (e.g., 1 mg/kg of enoxaparin twice daily or 100 U/kg of dalteparin twice daily)
  3. Low-molecular-weight heparin, as monotherapy (e.g., 1.5 mg/kg of enoxaparin once daily or 150 U/kg of dalteparin once daily).
  4. Fondaparinux (e.g., 7.5 mg once daily for patients between 50 and 100 kg) as a bridge to oral anticoagulation (investigational)
  5. Oral direct thrombin inhibitor (e.g., ximelagatran) as monotherapy (investigational)
- 

The ECG may show a classic S1Q3T3 pattern but more often will demonstrate a less commonly recognized sign of RV strain, T wave inversion in leads V1–V4. New incomplete or complete right bundle branch block is a very useful sign of RV dysfunction (3). The chest X-ray may show enlarged pulmonary arteries (4), especially an enlarged right descending pulmonary artery, indicating pulmonary hypertension.

Although the chest CT scan is performed primarily to detect or exclude PE (5), information about RV dilatation can also be gleaned. If the right ventricle is >90% the size of the left ventricle, then RV dilatation owing to RV dysfunction can be confidently diagnosed (6).

Among patients in whom the diagnosis of PE is established, the echocardiogram provides rapid and accurate risk stratification (7). Moderate or severe RV hypokinesis, pulmonary hypertension, a patent foramen ovale, and free-floating right-heart thrombus are markers for a high risk of death or recurrent PE (8).

### ***Importance of Risk Assessment***

The results of initial risk stratification will have a profound effect on treatment plan. When confident about which patients with PE are at low risk, physicians can focus immediately on providing them with intensive anticoagulation and thorough discharge planning (Table 3). Equally useful is identifying high-risk patients, especially those patients at high risk even though they appear clinically stable. Despite their apparent stability,

Table 4  
Possible Management Strategies for High-Risk Patients

- 
1. Thrombolysis (e.g., 100 mg of alteplase as a continuous infusion over 2 h) followed by intravenous unfractionated heparin as a bridge to oral anticoagulation
  2. Open surgical embolectomy
  3. Catheter embolectomy
  4. Placement of a retrievable or permanent inferior vena caval filter
- 

they are at risk of sudden decompensation and often require anticoagulation plus additional measures to ensure a successful outcome (Table 4).

### CARDIAC BIOMARKERS

Acute PE that poses high risk will cause RV shear stress, microinjury, and microinfarction. A dilated and overloaded RV will increase RV oxygen demand and diminish perfusion of the right coronary artery, even in the absence of atherosclerosis (9).

Cardiac troponin and the natriuretic peptides have emerged as the most useful cardiac biomarkers to date in risk stratification of acute PE. These biomarkers have a high negative predictive value for in-hospital death. Consequently, they can identify low-risk patients with PE. The cutoff levels for troponin are generally at the decision limit for myocardial infarction (MI). For natriuretic peptides, the cutoff levels are lower than those used for the diagnosis of left-sided congestive heart failure (10).

#### *Pathophysiology of Hemodynamic Stress and Cardiac Injury*

Acute PE increases pulmonary vascular resistance, partly owing to hypoxic vasoconstriction. In patients without prior cardiopulmonary disease, the mean pulmonary artery pressure can double to approx 40 mmHg. A further doubling of pulmonary artery pressure may occur in patients with chronic thromboembolic pulmonary hypertension (11).

Right ventricular enlargement owing to pressure overload causes a leftward shift of the interventricular septum, a manifestation of interventricular dependence that leads to reduced left ventricular (LV) preload and decreased cardiac output. RV contraction continues even after the left ventricle starts relaxing at end systole. The interventricular septum flattens during systole and then bulges toward the left ventricle, with paradoxical septal motion that distorts the normally circular LV cavity. There is diastolic LV impairment, owing to septal displacement, reduced LV distensibility, and impaired LV filling during diastole.

Increased RV afterload can cause RV dilatation, hypokinesis, tricuspid regurgitation with annular dilatation of the tricuspid valve, and ultimately RV failure. While this pathological process evolves, most patients maintain a normal systemic arterial pressure for 12–48 h and may give the impression of being “hemodynamically stable.” Then, often abruptly, systemic arterial hypotension resistant to supportive medical therapy and cardiac arrest may ensue (12).

Increased RV wall tension and oxygen demand, combined with reduced coronary perfusion and oxygen supply, may cause RV myocardial ischemia. As RV wall stress increases, cardiac ischemia may develop because increased RV pressure compresses the right coronary artery, diminishes subendocardial perfusion, and limits myocardial oxygen supply (13). This setting provides the substrate for abnormal release of cardiac biomarkers.

### *Cardiac Troponin*

As a more sensitive biomarker of myocardial injury, cardiac troponin is elevated more frequently than creatine kinase (CK) or CK-MB in patients with PE. The release of troponin in patients with PE is often quantitatively small, far less than typically observed in an ST-elevation MI (10). The release of troponin in this setting most likely results from acute RV pressure overload, impaired coronary blood flow, and severe hypoxemia that cause micronecrosis of the right ventricle.

In 1998, Pacouret et al. (14) reported that 2 of 29 patients with acute PE had elevated levels of troponin I, 13 and 5.6  $\mu\text{L}$  (normal in their laboratory:  $<1 \mu\text{L}$ ). Neither patient had clinical features to suggest high risk, nor did either patient have known coronary disease or renal insufficiency. Both patients survived. The investigators postulated that troponin elevation indicated the possibility of myocardial damage in patients with massive PE. However, they doubted that troponin could be used to risk stratify patients because their two patients had uncomplicated hospital courses, without electrocardiographic or echocardiographic findings to suggest that they were more susceptible than their other patients to an adverse clinical outcome.

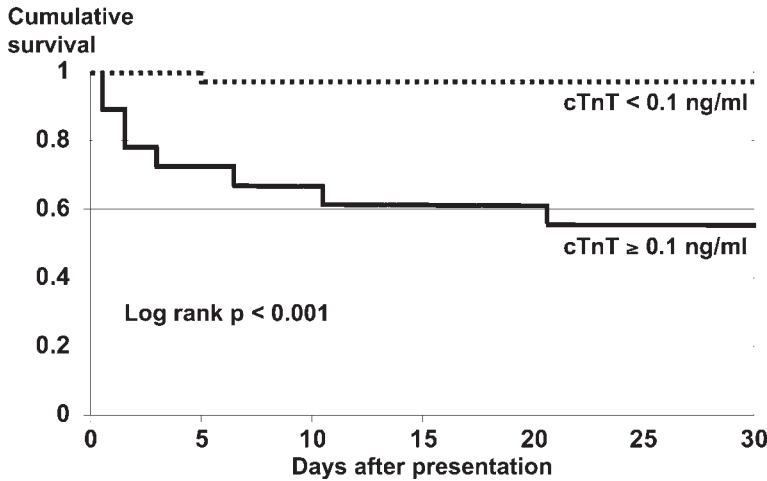
In 2000, Meyer et al. (15), from Goettingen, Germany, described 36 patients with PE of whom 16 had RV enlargement on echocardiogram. Of the 36 patients, 14 (39%) had elevated levels of troponin I. All but 4 of the 14 with an increased serum concentration of troponin had RV dilatation on echocardiogram. Thus, in contrast to the initial report from Pacouret et al. (14), patients with elevated troponin levels had a higher likelihood of having RV dysfunction.

Giannitsis et al. (16) went one step further in a larger study published the same year. Of 56 patients with PE, troponin T was elevated in 18 (32%). Patients with elevated troponin T levels were more likely to die in hospital, to suffer prolonged hypotension and cardiogenic shock, to require cardiopulmonary resuscitation, to need inotropic support, and to use mechanical ventilation than patients who did not have elevated troponin T levels. After multivariable regression analysis, elevated levels of troponin T remained the only independent predictor of in-hospital mortality (adjusted odds ratio [OR] 15.2; 95% confidence interval [CI]: 1.22–190). The 30-d mortality rate was 44% in troponin T-positive patients compared with 3% in troponin T-negative patients (Fig. 1).

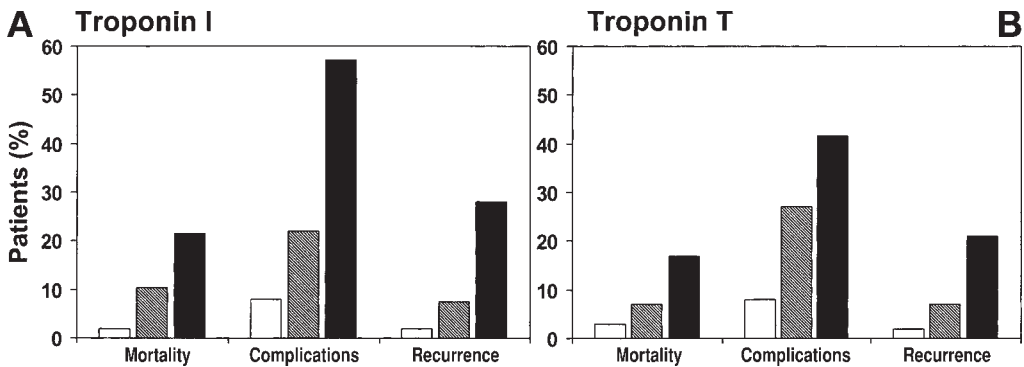
Konstantinides et al. (17) conducted the largest investigation of troponin and PE, called the Management Strategies and Prognosis of Pulmonary Embolism-2 (MAPPET-2) study. This prospective study of 106 patients with PE found elevated troponin I in 43 (41%) patients and elevated troponin T in 39 (37%). There was a significant association between abnormal troponin results and the two major end points, in-hospital mortality and complicated hospital course, defined as death or the need for thrombolysis, pressors, mechanical ventilation, or cardiopulmonary resuscitation. As troponin levels increased, the mortality and complication rates increased (Fig. 2). The negative predictive value of cardiac troponin results for major clinical events was 92 to 93%. These findings strongly support the use of troponins for risk stratification of patients with PE.

Troponin I and T are equally useful. Since MAPPET-2, additional studies have confirmed the finding of elevated troponin levels in some patients with submassive PE (18–20). The frequency ranges from 20 to 50%, depending on the acuity of the patients. In these more recent studies (19,20), elevation of troponin levels has consistently been associated with a complicated clinical course and higher than average likelihood of a fatal outcome. Conversely, lack of “troponin leak” is associated with a benign clinical course.





**Fig. 1.** Kaplan-Meier survival curve of troponin-positive vs troponin-negative patients with PE. cTnT, cardiac troponin T. (Reprinted with permission from ref. 16.)



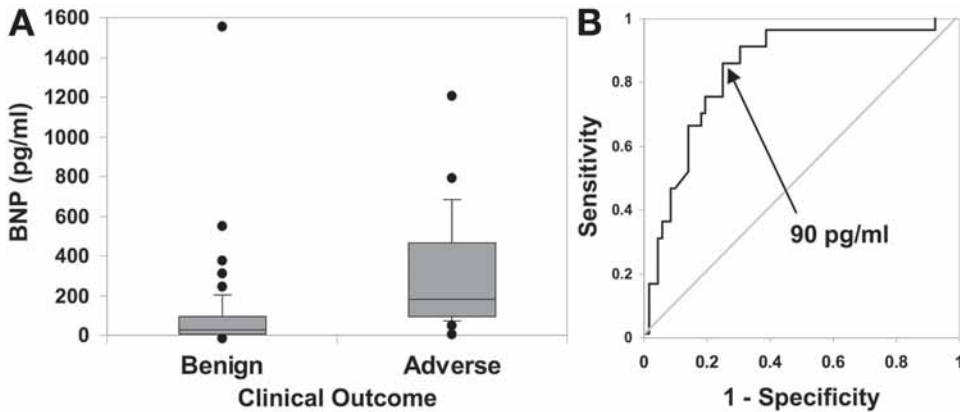
**Fig. 2.** Escalation of in-hospital mortality, complications, and recurrence rates depending on baseline troponin I (A) and T (B) levels: white bars, patients without detectable troponin; shaded bars, patients with moderately elevated troponin I (0.07–1.5 ng/mL) or troponin T (0.04–0.1 ng/mL); solid bars, high troponin levels, defined as >1.5 ng/mL for troponin I and >0.1 ng/mL for troponin T. (Reprinted with permission from ref. 17.)

### *B-Type Natriuretic Peptide*

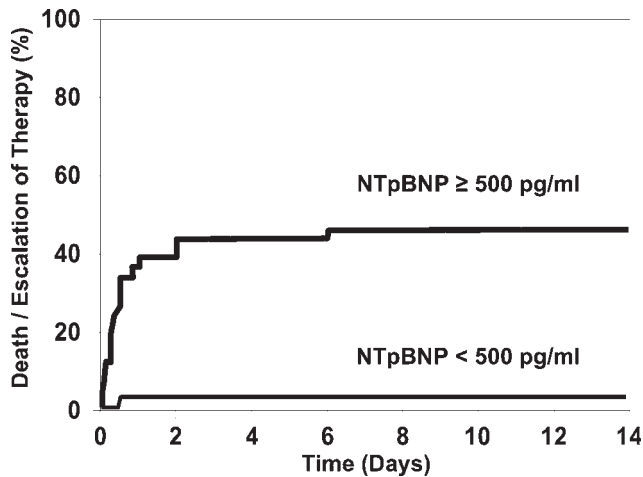
B-type natriuretic peptide (BNP) is released predominantly by the cardiac ventricles in response to myocardial wall stretch (*see* Chapter 21) (21).

ten Wolde et al. (22) published the first study showing that the plasma concentration of BNP is associated with the risk of adverse outcome in patients with acute PE. They examined 110 consecutive hemodynamically stable patients and divided their BNP results into terciles: 0–2.5, 2.5–21.7, and >21.7 pmol/L. When they followed patients for 3 mo after the diagnosis of PE, there were no deaths in the lowest tercile, two deaths in the middle tercile, and nine deaths in the highest tercile.

In a separate study, Kucher et al. (23) measured the plasma concentration of BNP in 73 consecutive patients with acute PE. They used a prespecified cutoff of <90 pg/mL for predicting the absence of a major adverse cardiovascular event. In 20 patients with adverse clinical events, the median BNP was 194 compared with 39 among patients with a benign clinical course (Fig. 3). In multivariable analysis, the adjusted OR for an adverse clinical



**Fig. 3.** Box plots with BNP levels according to clinical outcome. (A) Median values, 50 and 95% CIs, and outliers for BNP; (B) ROC curve of BNP for adverse clinical outcome. (Reprinted with permission from ref. 23.)

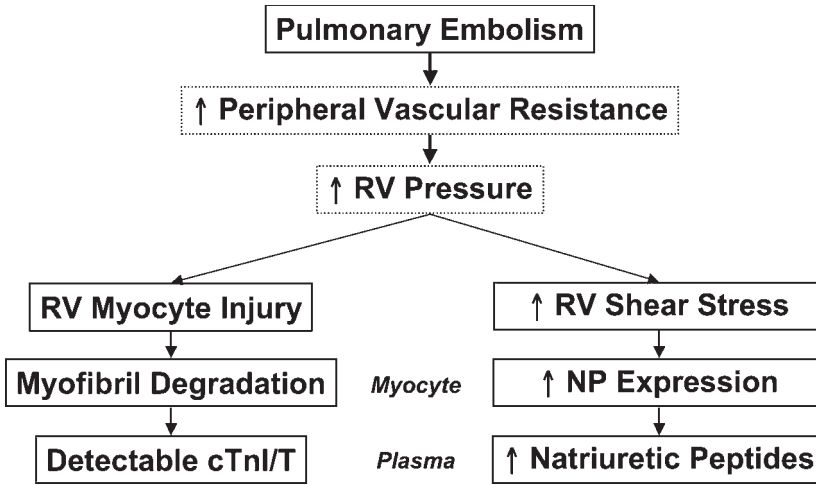


**Fig. 4.** Cumulative rate of adverse clinical outcomes according to proBNP (NTpBNP) levels  $<500$  vs  $\geq 500$  pg/mL ( $p < 0.0001$ ). (Reprinted with permission from ref. 24.)

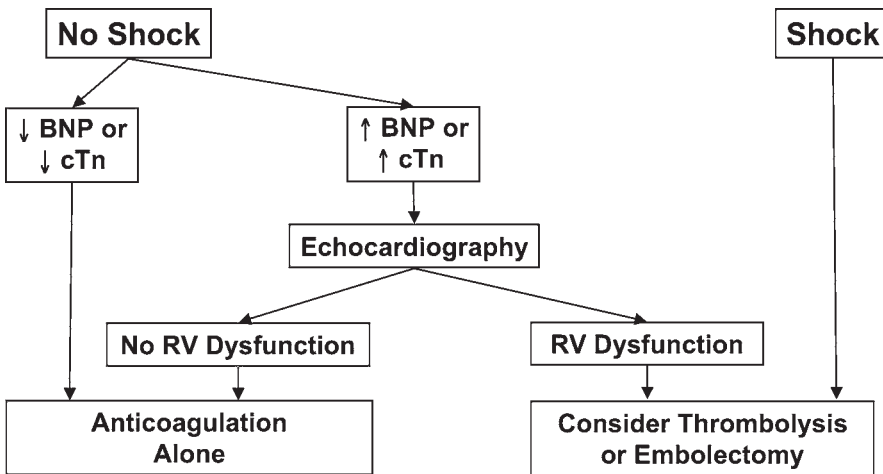
event in patients with BNP  $> 90$  pg/mL was 8.0 (95% CI: 1.3–50;  $p = 0.03$ ). The sensitivity, specificity, and negative and positive predictive value were 85, 75, 93, and 57%, respectively. However, the most sensitive BNP cutoff, identified by receiver operating characteristic (ROC) analysis, was  $< 50$  pg/mL. Sensitivity, specificity, and negative and positive predictive value of BNP levels  $< 50$  pg/mL were 95, 60, 97, and 48%, respectively.

Although N-terminal proBNP (NT-proBNP) has not been studied as extensively as BNP in patients with PE, the available data suggest similar prognostic relationships. Low levels of NT-proBNP are associated with an uneventful hospital course, whereas elevated levels portend a higher risk of adverse clinical outcomes (24,25) (Fig. 4).

Despite these promising data, the utility of BNP in patients with PE remains less well established than that of troponin. For example, in a study of 50 patients with PE, BNP levels were increased in the presence of right ventricle dysfunction but were not predictive of mortality or in-hospital complications (26). Moreover, the appropriate cutoff level for BNP for risk assessment in patients with PE is not as clear as for troponin, for which any elevation is abnormal and appears to indicate an increased risk of a complicated



**Fig. 5.** Mechanism of cardiac biomarker level elevation in pulmonary embolism. RV, right ventricular. NP, natriuretic peptides; cTnI, cardiac troponin I. (Reprinted with permission from ref. 10.)



**Fig. 6.** Pulmonary embolism management strategy. RV, right ventricular; cTn, cardiac troponin. (Reprinted with permission from ref. 10.)

hospital course. Finally, it remains unclear whether the natriuretic peptides will be complementary to or alternative markers for the troponin.

### CONCLUSION

RV microinfarction and right ventricular shear stress are the most likely explanations for the rise in troponin and natriuretic peptides, respectively, in certain patients with acute PE (Fig. 5). These elevations in cardiac biomarkers reflect an increased likelihood that the hospital course will be complicated despite immediate treatment with anticoagulation. Biomarkers are not useful in patients who present with cardiogenic shock owing to PE (Fig. 6). These patients require more aggressive management including consideration of emergency thrombolysis or embolectomy. So far, biomarkers for PE have been evaluated only in cohort studies. Future trials will assess these biomarkers in formal prospective management trials.

## REFERENCES

1. Wicki J, Perrier A, Perneger TV, Bounameaux H, Junod AF. Predicting adverse outcome in patients with acute pulmonary embolism: a risk score. *Thromb Haemost* 2000;84:548–552.
2. Goldhaber SZ, Elliott CG. Acute pulmonary embolism: Part II: risk stratification, treatment, and prevention. *Circulation* 2003;108:2834–2838.
3. Daniel KR, Courtney DM, Kline JA. Assessment of cardiac stress from massive pulmonary embolism with 12-lead ECG. *Chest* 2001;120:474–481.
4. Elliott CG, Goldhaber SZ, Visani L, DeRosa M. Chest radiographs in acute pulmonary embolism: results from the International Cooperative Pulmonary Embolism Registry. *Chest* 2000;118:33–38.
5. Schoepf UJ, Goldhaber SZ, Costello P. Spiral CT for acute pulmonary embolism. *Circulation* 2004;109:2160–2167.
6. Quiroz R, Kucher N, Schoepf UJ, et al. Right ventricular enlargement on chest computed tomography: prognostic role in acute pulmonary embolism. *Circulation* 2004;109:2401–2404.
7. Grifoni S, Olivetto I, Cecchini P, et al. Short-term clinical outcome of patients with acute pulmonary embolism, normal blood pressure, and echocardiographic right ventricular dysfunction. *Circulation* 2000;101:2817–2822.
8. Goldhaber SZ. Echocardiography in the management of pulmonary embolism. *Ann Intern Med* 2002;136:691–700.
9. Lualdi JC, Goldhaber SZ. Right ventricular dysfunction after acute pulmonary embolism: pathophysiologic factors, detection, and therapeutic implications. *Am Heart J* 1995;130:1276–1282.
10. Kucher N, Goldhaber SZ. Cardiac biomarkers for risk stratification of patients with acute pulmonary embolism. *Circulation* 2003;108:2191–2194.
11. Goldhaber SZ, Elliott CG. Acute pulmonary embolism: Part I: Epidemiology, pathophysiology, and diagnosis. *Circulation* 2003;108:2726–2729.
12. Goldhaber SZ. Cardiac biomarkers in pulmonary embolism. *Chest* 2003;123:1782–1784.
13. Wood KE. Major pulmonary embolism: review of a pathophysiologic approach to the golden hour of hemodynamically significant pulmonary embolism. *Chest* 2002;121:877–905.
14. Pacouret G, Schellenberg F, Hamel E, Charbonnier B, Mouray H. Troponine I dans l'embolie pulmonaire aigue massive: résultats d'une série prospective. *Presse Medicale* 1998;27:1627.
15. Meyer T, Binder L, Hruska, N, Luthe H, Buchwald AB. Cardiac troponin I elevation in acute pulmonary embolism is associated with right ventricular dysfunction. *J Am Coll Cardiol* 2000;36:1632–1636.
16. Giannitsis E, Muller-Bardorff M, Kurowski V, et al. Independent prognostic value of cardiac troponin T in patients with confirmed pulmonary embolism. *Circulation* 2000;102:211–217.
17. Konstantinides S, Geibel A, Olschewski M, et al. Importance of cardiac troponins I and T in risk stratification of patients with acute pulmonary embolism. *Circulation* 2002;106:1263–1268.
18. Douketis JD, Crowther MA, Stanton EB, Ginsberg JS. Elevated cardiac troponin levels in patients with submassive pulmonary embolism. *Arch Intern Med* 2002;162:79–81.
19. Pruszczyk P, Bochowicz A, Torbicki A, et al. Cardiac troponin T monitoring identifies high-risk group of normotensive patients with acute pulmonary embolism. *Chest* 2003;123:1947–1952.
20. Yalamanchili K, Sukhija R, Aronow WS, Sinha N, Fleisher AG, Lehrman SG. Prevalence of increased cardiac troponin I levels in patients with and without acute pulmonary embolism and relation of increased cardiac troponin I levels with in-hospital mortality in patients with acute pulmonary embolism. *Am J Cardiol* 2004;93:263, 264.
21. Jimenez CH, Kleinschmidt K. B-type natriuretic peptide: clinical utility in the emergency department and in-hospital setting. *Clin Cardiol Consensus Rep* August 1, 2003; pp. 1–12.
22. ten Wolde M, Tulevski II, Muilder JW, et al. Brain natriuretic peptide as a predictor of adverse outcome in patients with pulmonary embolism. *Circulation* 2003;107:2082–2084.
23. Kucher N, Printzen G, Goldhaber SZ. Prognostic role of BNP in acute pulmonary embolism. *Circulation* 2003;107:2545–2547.
24. Kucher N, Printzen G, Doernhoefer T, Windecker S, Meier B, Hess OM. Low pro-brain natriuretic peptide levels predict benign clinical outcome in acute pulmonary embolism. *Circulation* 2003;107:1576–1578.
25. Pruszczyk P, Kostrubiec M, Bochowicz A, et al. N-terminal pro-brain natriuretic peptide in patients with acute pulmonary embolism *Eur Respir J* 2003;22:1–5.
26. Kruger S, Graf J, Merx MW, et al. Brain natriuretic peptide predicts right heart failure in patients with acute pulmonary embolism. *Am Heart J* 2004;147:60–65.



# 10

---

## Cardiac Troponin in Conditions Other Than Acute Coronary Syndromes

---

*Fred S. Apple, PhD  
and David A. Morrow, MD, MPH*

### CONTENTS

INTRODUCTION  
HEART FAILURE  
TRAUMA  
ELECTRICAL CARDIOVERSION  
PULMONARY EMBOLI  
SEPSIS  
CRITICAL ILLNESS OTHER THAN SEPSIS  
MYOCARDITIS  
STROKE  
NONCARDIAC SURGERY  
EXERCISE  
NEWBORN INFANTS/PEDIATRICS  
DRUG-INDUCED MYOCARDIAL DAMAGE  
END-STAGE RENAL DISEASE  
MISCELLANEOUS PATHOLOGIES  
PREANALYTIC INTERFERENCES  
CONCLUSION  
REFERENCES

---

### SUMMARY

This chapter reviews the evidence-based literature demonstrating increased cardiac troponins in patients presenting without ischemic heart disease. In several clinical settings, increased cardiac troponin is associated with both short- and long-term adverse outcomes. In addition, mechanisms responsible for analytical false-positive cardiac troponin results are addressed.

**Key Words:** Cardiac troponin; myocardial injury; nonischemic pathology; heart disease.

From: *Contemporary Cardiology:  
Cardiovascular Biomarkers: Pathophysiology and Disease Management*  
Edited by: David A. Morrow © Humana Press Inc., Totowa, NJ

## INTRODUCTION

Cardiac troponin I (cTnI) and cardiac troponin T (cTnT) have been recognized by both the cardiology and laboratory medicine communities to be the most sensitive and specific biomarkers for detection of irreversible myocardial damage (1–4). Both cTnI and cTnT have been shown to be tissue specific for the myocardium (5). However, increases in cTnI and cTnT are not specific to the mechanism of myocardial injury, and damage can occur from numerous mechanisms in addition to acute ischemia (6,7). Thorough clinical evaluation and serial monitoring of cardiac troponin will assist in discriminating acute coronary syndrome (ACS) presentations from nonischemic causes of an increase in the concentration of cardiac troponin. In the earliest report identifying hospitalized patients without acute myocardial infarction (AMI) who had increased troponin concentrations, 79 patients randomly sampled within 12 h of admission from medical and surgical units demonstrated cTnT increases from 0.13 to as high as 7.8  $\mu\text{g/L}$  (normal:  $\leq 0.1 \mu\text{g/L}$ ) in the setting of a variety of conditions, including lung cancer, drug overdoses, small bowel obstruction, stroke, end-stage renal disease (ESRD), pneumonia, and scleroderma (6). During the past 18 yr since that report, numerous case reports and clinical studies have demonstrated that cTnT and cTnI are the preferred specific biomarkers to detect myocardial injury in the clinical setting of nonmyocardial ischemic presentations. In some of these clinical situations, an increased concentration of cardiac troponin is associated with a higher risk of adverse events in the short and/or long term. Research is needed to elucidate the pathophysiological mechanisms associated with such increases in cardiac troponin in each category of pathology. In addition, clinicians must recognize that increased cardiac troponin does not necessarily equate to AMI and in the vast majority of cases does not indicate a false-positive finding.

Table 1 provides a list of clinical settings in which increased concentrations of cardiac troponin have been shown to occur in the absence of ACS. The purpose of this chapter is to review the literature regarding studies and case presentations of increased levels of cardiac troponin in these settings. Furthermore, this chapter briefly reviews reports that address spurious, false-positive and false-negative cardiac troponin values owing to pre-analytic interferences in the absence of myocardial damage.

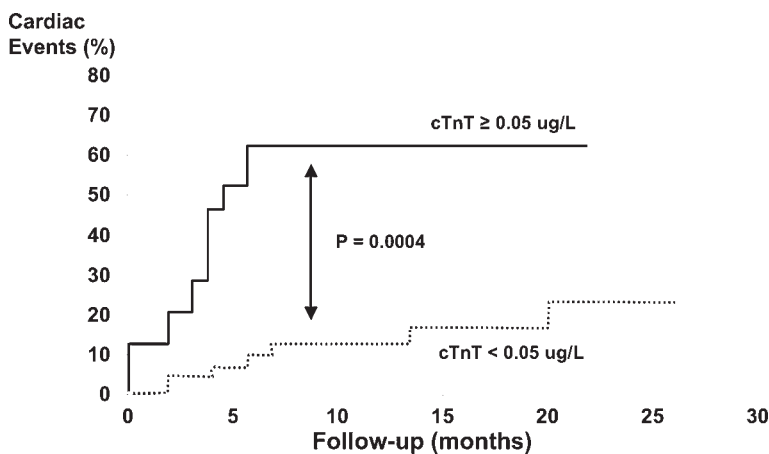
## HEART FAILURE

Increased concentrations of cTnI and cTnT have been found in patients with congestive heart failure (CHF) (8–12). Heart failure is a dynamic process with progressive severity and is structurally characterized by cellular degeneration and multiple foci of myocardial cell death. The specific underlying mechanisms of myocyte necrosis likely vary between etiologies of heart failure and in some instances remain unclear. In the majority of patients with heart failure studied, increased concentrations of cardiac troponin have been detected predominantly in patients with advanced CHF (New York Heart Association III and IV classifications) and are distinguished with evidence of increased cardiac events over a 2-yr period (Fig. 1) (8). Increased cTnI and cTnT values in patients with advanced heart failure are also independently associated with a decline in left ventricular ejection fraction (LVEF) and higher mortality. In addition, the prognostic information from cardiac troponin appears to be additive to other clinical indicators associated with the risk of death in heart failure. For example, the combination of increased cTnI and increased B-type natriuretic peptide (BNP) identifies heart failure patients with a markedly (12-fold)

**Table 1**  
**Clinical Settings Frequently Associated**  
**With Increased Cardiac Troponin Concentrations in Absence of ACSs**

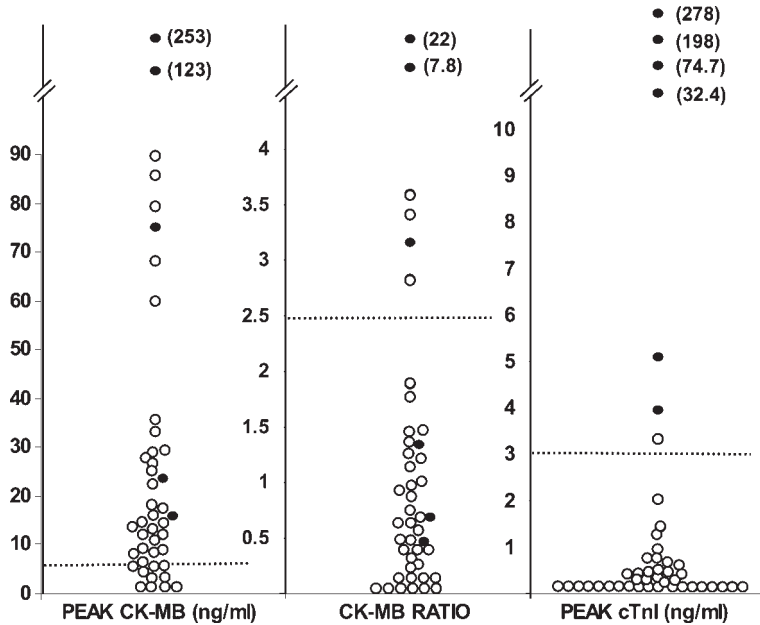
- CHF<sup>a</sup>
- Trauma, cardiac contusion
- Cardioversion, electrical defibrillation
- Pulmonary embolism, edema<sup>a</sup>
- Sepsis, septic shock<sup>a</sup>
- Myocarditis
- Exercise, vital exhaustion
- Stroke<sup>a</sup>
- Noncardiac, vascular surgery
- ESRD<sup>a</sup>
- Hypertension
- Hypotension
- Critically ill intensive care patients<sup>a</sup>
- Aneurysmal subarachnoid hemorrhage
- Drugs of abuse toxicity, including ethanol
- Chemotherapy
- Heart surgery, transplantation
- Polymyositis, dermatomyositis
- Cardiomyopathy
- Rhabdomyolysis, trauma (nonchest)
- Hematological malignancies
- Acute pericarditis
- Amyloid cardiomyopathy
- Idiopathic dilated cardiomyopathy
- Neonates
- Lung disease

<sup>a</sup>Evidence of role of cardiac troponin for risk stratification for short- or long-term outcomes.



**Fig. 1.** Kaplan-Meier curves for patients with CHF assessed by cTnT concentration. (Reproduced from ref. 8.)





**Fig. 2.** Peak cTnI, CK-MB, and ratio of CK-MB to total CK in patients without cardiac contusion (○) and with cardiac contusion (●). Horizontal lines indicates upper reference cutoffs. (Reproduced from ref. 15.)

higher risk of death (9). Furthermore, available evidence suggests that ongoing myofibrillar degradation, resulting in increased cardiac troponin concentrations, parallels the severity of the disease. A potential future clinical role for troponin testing in guiding treatment strategies for patients with heart failure is discussed in Chapter 8.

## TRAUMA

### *Diagnosis of Blunt Cardiac Trauma*

Concentrations of both cTnI and cTnT have been shown to be increased in trauma patients, especially following cardiac contusion (13–16). Blunt cardiac injury typically results from direct compression of the heart or decelerating forces delivered to the chest. Such cardiac injury may occur even after relatively low-energy trauma without other obvious injuries. In the large majority of patients with blunt chest trauma studied, small to moderate increases in cardiac troponin were found, implying that the extent of injury is small (14,15). The results of testing for cardiac troponin were able to differentiate the majority of patients with isolated increased creatine kinase-MB (CK-MB) values related to skeletal muscle damage from those with myocardial injury. In one representative study of 44 patients with blunt chest trauma, 37 trauma patients without cardiac contusion had increases in CK-MB without a rise in cTnI (15). In the six patients with evidence of cardiac injury by echocardiography, all had increased cTnI values, based on serial sampling over 24 h following presentation (Fig. 2) (15). In that study, cTnI offered superior specificity for the diagnosis of blunt cardiac trauma to both CK-MB measurement and electrocardiography, which were abnormal in 70 and 95% of those with no wall motion abnormalities on cardiac echo.

These data have supported the consensus that cardiac troponin is superior to CK-MB for the diagnosis of blunt cardiac injury. Nevertheless, although other, larger studies have confirmed the high specificity of troponin with respect to a clinical diagnosis of cardiac contusion, the sensitivity may be substantially lower (12–31%). For example, Bertinchant et al. (14) studied hemodynamically stable patients with suspected blunt cardiac injury ( $n = 94$ ). Based on electrocardiographic and echocardiographic findings, 28% of patients were given a diagnosis of “myocardial contusion.” Elevated levels of cTnI ( $\oplus 0.1 \mu\text{g/L}$ ; Beckman Access) and cTnT ( $>0.1 \mu\text{g/L}$ ) were highly specific (97 and 100%, respectively) for the diagnosis of “myocardial contusion” but offered low sensitivity (23 and 12%, respectively) (14).

### ***Cardiac Troponin and Clinical Decision Making in Blunt Chest Trauma***

The aforementioned data confirm the high probability of electrocardiographic and echocardiographic abnormalities among patients with chest trauma and elevated troponin. However, from this evidence alone, it is not clear whether management of patients with suspected blunt cardiac trauma should be altered on the basis of troponin results. Few studies have evaluated the usefulness of troponin for assessing the risk of important clinical manifestations of blunt cardiac injury. In one study of 115 patients requiring intensive care for blunt chest trauma, 16.5% developed significant clinical manifestations (arrhythmia or pericardial effusion requiring treatment, cardiogenic shock, or hypotension unexplained by other conditions) (17). cTnI ( $>1.5 \text{ ng/mL}$ ; Dimension RxL) provided a stronger positive predictive value (48%) compared to the electrocardiogram (ECG) (28%), while both had high negative predictive values (93 and 95%, respectively). When used together, “negative” findings on the ECG and serial measurements of cTnI identified a population of patients (40%) who suffered no important clinical manifestations of cardiac trauma. The high negative predictive capacity of this combined testing in this study supports the possibility of using such noninvasive information to identify low-risk candidates for early discharge. However, other investigators have had conflicting observations, with up to 73% of patients who developed subsequent cardiac events presenting with normal results of testing for cTnT (18).

### ***Clinical Role***

Interpretation of the aggregate evidence is made difficult by substantial variation in enrollment and diagnostic criteria, troponin thresholds, and clinical end points used in the trauma studies noted above. Nevertheless, it is clear that cardiac troponin offers superior specificity to CK-MB and is the preferred biomarker for detection of cardiac injury in the setting of trauma. Further research is necessary to confirm whether patients with normal ECG and troponin testing are at acceptably low risk to permit early discharge without observation. This application is likely to become more reliable as improved analytic precision at low concentrations enables the use of lower cut points for troponin. Clinical studies will be necessary to determine whether “minor” increases in troponin concentration are important for management.

## **ELECTRICAL CARDIOVERSION**

Conflicting reports have been published regarding the release of cardiac troponin following electrical cardioversion (19–23). The majority of studies report minor increases in both cTnT and cTnI following direct-current cardioversion in patients presenting with

atrial or ventricular fibrillation. Release of cardiac troponin occurs within 3–6 h after cardioversion, with blood concentrations declining to baseline within 24 h. In general, <50% of patients show an increase, with the percentage dependent on the cutoff applied. Overall, the data suggest that occult, asymptomatic myocardial injury can occur following electrical cardioversion. Consistent with this biochemical evidence, histopathological studies have demonstrated morphological and functional derangement of cardiac myocytes following electrical shocks in animal models. Data are mixed as to whether the presence of and extent of increase in troponin are related to the number of shocks or to the amount of energy delivered.

At the present time, there is no evidence that routine measurement of cardiac troponin after elective cardioversion is useful for patient management. It is expected that slight increases in troponin concentration will be evident in some patients. More substantial increases are likely indicative of myocardial damage unrelated to the external shock and should prompt a search for the etiology of injury. More information is needed regarding interpretation of elevation of cardiac troponins in patients surviving cardioversion for out-of-hospital cardiac arrest. Until new data suggest otherwise, it is reasonable to maintain a high index of clinical suspicion for myocardial ischemia and undertake appropriate evaluation in patients with elevated cardiac troponins after resuscitation from cardiac arrest.

## PULMONARY EMBOLI

Both cTnT and cTnI are increased in from one-third to more than one-half of patients clinically diagnosed with pulmonary embolism (PE), although the number of patients studied is few ( $n < 200$ ) (24–26). The presence of increased concentrations of cTnI appears to identify patients with right ventricular dysfunction and larger defects of pulmonary perfusion. Furthermore, abnormal results of troponin testing are associated with poor-long term survival (25,26). Figure 3 shows a 3-yr Kaplan-Meier survival curve demonstrating a greater relative risk (RR) of death (RR = 2.31) for patients with a positive result for cTnT. Thus, cardiac troponin appears to provide information that may be valuable to both risk stratification and management of PE. Details regarding the potential clinical role for cardiac troponin in patients with PE are discussed in Chapter 9.

## SEPSIS

### *Frequency and Pathobiology of Troponin Elevation in Sepsis*

Numerous reports have established that both cTnI and cTnT are biomarkers of myocardial injury in sepsis and septic shock or other systemic immune response syndromes (SIRSs), such as pancreatitis (27–32). Septic patients presenting to tertiary, urgent, and intensive care settings without documented heart disease have abnormal troponin results in a substantial proportion (31–85%) of cases. In a representative study among adult patients ( $n = 46$ ) with septic shock, levels of cTnI ( $\oplus 0.4 \mu\text{g/L}$ ; Stratus II) and cTnT ( $>0.1 \mu\text{g/L}$ ; Elecsys 2010) were found to be elevated in 50 and 36%, respectively, with peak concentrations (median, interquartile range) of  $1.4 \mu\text{g/L}$  (0.8–6.8  $\mu\text{g/L}$ ) for cTnI and  $0.66 \mu\text{g/L}$  (0.19–1.51  $\mu\text{g/L}$ ) for cTnT (31).

The mechanism responsible for minor myocardial damage in this setting is not completely understood and a number of potential contributors should be considered. Certainly, elderly patients with sepsis are at risk of concomitant coronary atherosclerosis and may

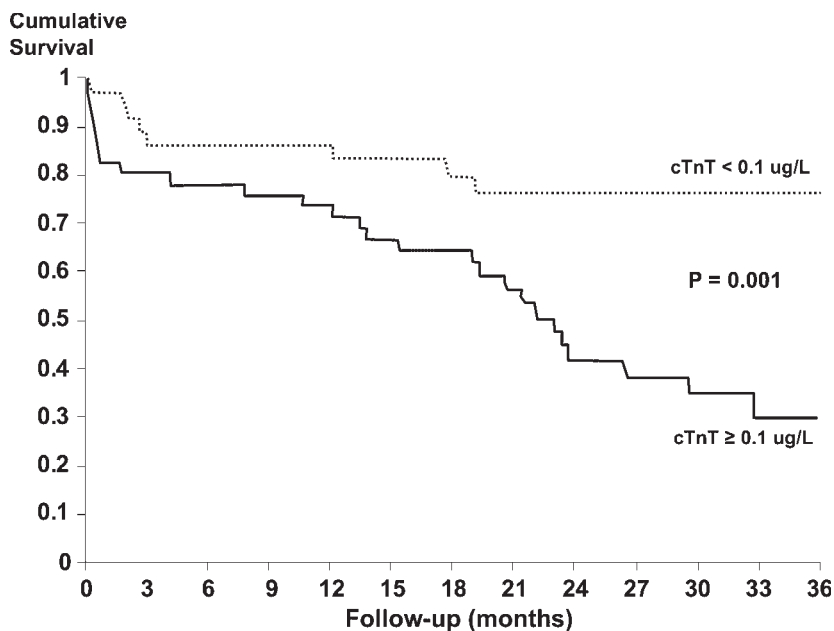
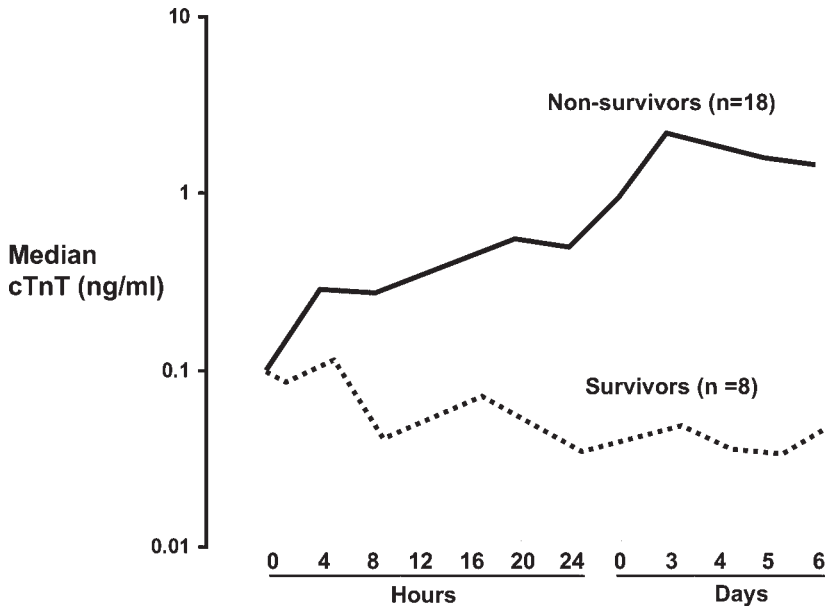


Fig. 3. Kaplan-Meier survival curves for patients with pulmonary edema. (Reproduced from ref. 25.)

develop myocardial ischemia during the stress of major illness. However, elevated levels of troponin have been observed in children with meningococcal sepsis (62%) in the obvious absence of coronary artery disease (CAD). In addition, a substantial proportion of adults with abnormal levels of cardiac troponin during sepsis have no evidence of obstructive CAD or histopathological evidence of irreversible myocardial injury. For example, in one study 58% of patients with elevated cTnI had no appreciable CAD when evaluated by coronary angiography, stress echocardiography, or pathological findings (32). Although disseminated microthrombi and small-vessel coronary obstruction should be considered, it is probable that myocardial injury during sepsis also can result from non-ischemic mechanisms. Transient myocardial dysfunction is present in up to 40% of patients with sepsis. The prevailing contemporary opinion relates this dysfunction to direct myocardial depressant effects of inflammatory mediators elaborated in SIRSs rather than global myocardial ischemia owing to disrupted coronary autoregulation, as once thought (29). Candidate mediators that may act as “myocardial depressant factors” in SIRSs include lipopolysaccharide, prostanoids, nitric oxide, and inflammatory cytokines such as tumor necrosis factor (TNF)- $\alpha$  and interleukin-1 $\beta$ . Notably, patients with sepsis and impaired left ventricular function show greater increases in cardiac troponin, potentially tying myocardial toxic/depressant effects of inflammatory cytokines to the release of cardiac troponin.

#### *Association of Increases in Troponin With Outcomes in Sepsis*

Higher cardiac troponin concentrations in patients with sepsis have been associated with higher mortality (Fig. 4) in a few published studies to date (30). Such patients are also more likely to have other markers of a less favorable clinical status as captured by critical care indices of severity of illness (e.g., APACHE II score). Therefore, it is not yet clear whether troponin is an *independent* predictor of poor outcomes in sepsis.



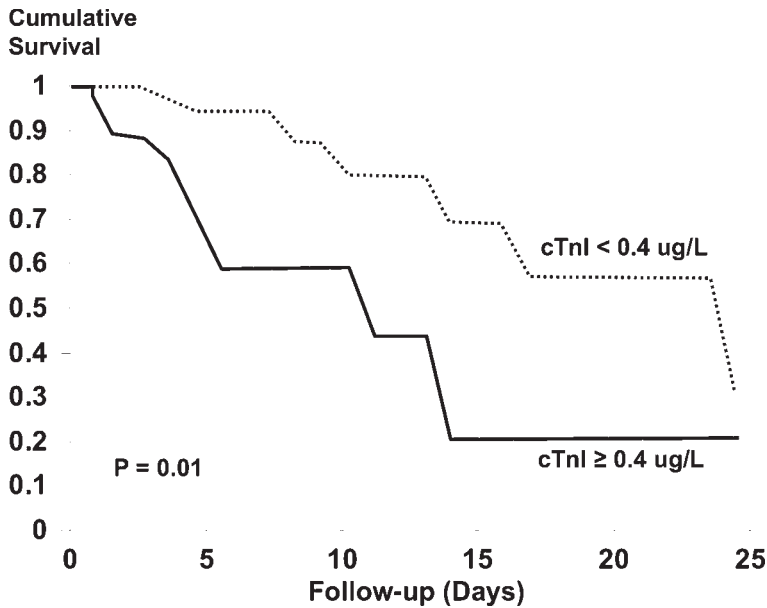
**Fig. 4.** Median serum cTnT concentrations for survivors (dotted line) and nonsurvivors (solid line) in patients with sepsis during ICU stay. (Reproduced from ref. 30.)

### *Clinical Role for Troponin Testing in Sepsis*

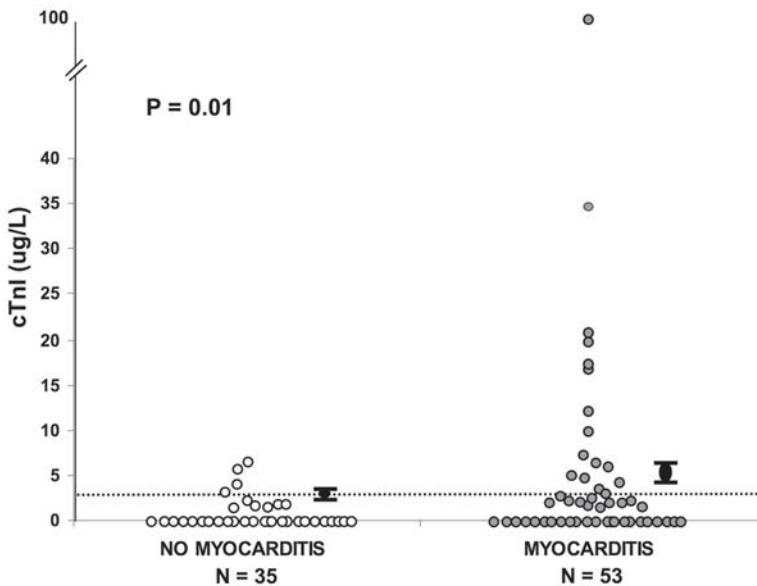
At present, data supporting any clinical application of troponin for prognostic assessment in SIRSs are limited, and, more important, no specific therapeutic strategies that might modify the risk of patients with SIRS have been identified. Application of aggressive antithrombotic, antiplatelet, and invasive therapies effective for patients presenting with ACS and elevated troponin are not supported by clinical data in this setting and may expose patients with sepsis to additional, unacceptable risks. Specific anti-inflammatory therapies such as antibodies to TNF- $\alpha$  have shown promising preliminary results. Research providing additional insight into the pathogenesis of troponin elevation in sepsis may also further clarify the mechanisms underlying myocardial dysfunction and guide the development of new approaches to the treatment of this highly morbid syndrome (33).

### CRITICAL ILLNESS OTHER THAN SEPSIS

Troponin has also been recognized as an independent biomarker of mortality among critically ill patients (34–37). An initial observational study examining 209 admissions to a medical and respiratory intensive care unit (ICU) showed that 32 (15%) had increased cTnI (34). However, only 12 of these 32 patients (37%) were recognized as having myocardial injury by the medical staff, with 20 patients (63%) unrecognized without the assistance of cTnI. Mortality in patients with increased cTnI was 40% compared with 15% in patients with normal troponin values. These findings were confirmed in a study that observed increased short-term mortality in noncardiac patients presenting at the emergency department (ED) (37). Patients presenting with an increased cTnI had an RR of death of 3.08 within 5 d of presentation, as shown in Fig. 5 (37).



**Fig. 5.** Survival curves of noncardiac, critically ill ED patients stratified by cTnI concentrations. (Reproduced from ref. 37.)



**Fig. 6.** Relationship between cTnI and severity of myocarditis in 53 patients. Solid ovals between black bars represent the mean  $\pm$  SE for each group. (Reproduced from ref. 39.)

## MYOCARDITIS

Several studies (in both humans and a murine model) have established that cTnI and cTnT are superior to CK-MB for detection of myocyte injury in myocarditis (Fig. 6) (38–41). Cardiac troponin monitoring provided sensitive evidence of clinically suspected myocarditis in the first month after the onset of heart failure symptoms. However, as for other

methods for the diagnosis of myocarditis, negative results do not exclude the presence of the disease. Nevertheless, the finding of increased levels of troponin in patients with a clinical story consistent with myocarditis is associated with a higher probability of histological or immunohistological evidence of myocarditis on endomyocardial biopsy. A correlation of troponin concentration and the severity of myocarditis has not been consistently observed.

### ***Clinical Role for Troponin in Suspected Myocarditis***

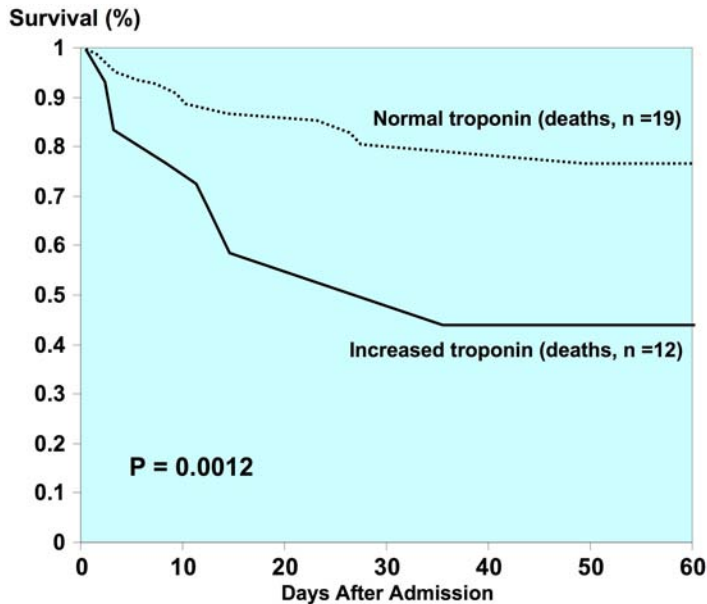
Cardiac troponins frequently provide evidence of ongoing myocyte damage in patients with suspected myocarditis when CK-MB levels are within the normal range but remain limited as a diagnostic test by poor sensitivity. Nevertheless, owing to the similarly modest sensitivity of endomyocardial biopsy (the “gold standard” for diagnosis), some experts have recommended measurement of cardiac troponin and correlation with the results of histological assessment in all patients with suspected myocarditis (42). When elevated levels of troponin are detected in the absence of histological and/or immunohistological evidence of myocarditis, sampling error of the biopsy is a strong possibility; however, other nonischemic and ischemic causes of myocyte necrosis should be considered. Conversely, myocarditis should be among the diagnostic possibilities for patients presenting with chest symptoms and elevated troponins who subsequently are shown to be free of significant epicardial coronary disease.

## **STROKE**

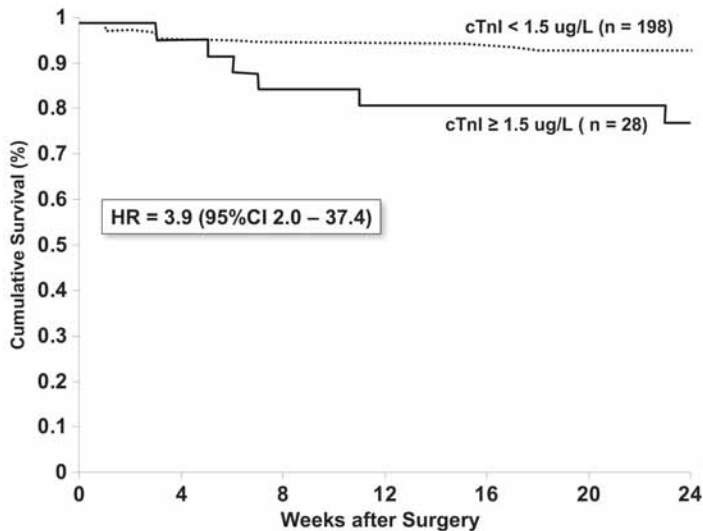
A relationship between abnormal cTnT concentrations at hospital admission and higher mortality in patients admitted with an acute ischemic stroke has been demonstrated in several (43,44) but not all (45) studies. In a study of 181 patients admitted with stroke among whom cTnT concentrations were measured serially over 72 h after admission, a peak cTnT level  $>0.1$   $\mu\text{g/L}$  was associated with a 40% risk of mortality vs 13% for patients with a normal value (Fig. 7) (43). Although other studies have demonstrated that increased CK-MB concentrations after stroke are often not of myocardial origin (44), findings with troponin draw attention to the seldom-recognized cardiac complications of stroke. Nevertheless, it is important for clinicians to recognize that the etiology of myocardial injury in this setting is believed to relate predominantly to mechanisms other than acute atherothrombosis with surges in catecholamines during stroke playing a primary role. Thus, treatment should be aimed primarily at the underlying cerebrovascular accident.

## **NONCARDIAC SURGERY**

Numerous studies have now confirmed the successful role of monitoring either cTnI or cTnT after noncardiac surgery to detect perioperative MI (46–50). In a study of 96 patients undergoing vascular surgery, serial measurements of cTnI confirmed 8 patients who had new cardiac abnormalities detected during echocardiography (46). Measurement of cTnI differentiated the high incidence (19%) of false-positive increases in CK-MB associated with skeletal muscle release of CK-MB (46). More important, postoperative increases in cTnI and cTnT are associated with an increased risk of short-term mortality after vascular surgery (Fig. 8) (48) as well as nonvascular procedures. Although abnormal results of troponin testing are more frequent in patients undergoing vascular surgery, the incidence of detectable myocardial injury appears similar between nonvascular and vascular surgery after adjusting for the presence of concomitant CAD.



**Fig. 7.** Kaplan-Meier survival curves for 181 patients with acute stroke stratified by normal and increased cTnT concentrations. (Reproduced from ref. 43.)

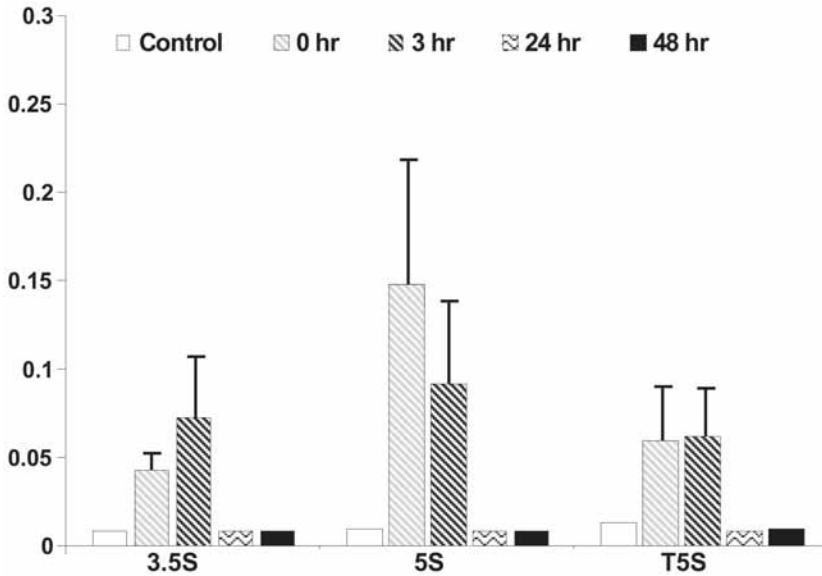


**Fig. 8.** Kaplan-Meier survival curves in 229 postoperative vascular surgery patients based on cTnI levels. CI, confidence interval; HR, hazard ratio. (Reproduced from ref. 48.)

## EXERCISE

Several studies have observed increases in the concentration of cTnI and cTnT in highly trained athletes during training and after athletic competition (51–63). The majority of reports have addressed marathon runners and triathletes. The early literature confused the presence of increased CK-MB in athletes with myocardial injury. This hypothesis was dispelled with the evidence that CK-MB-enriched skeletal muscle, injured during intense exercise, was responsible for the increased serum CK-MB values (62,63). Substantial



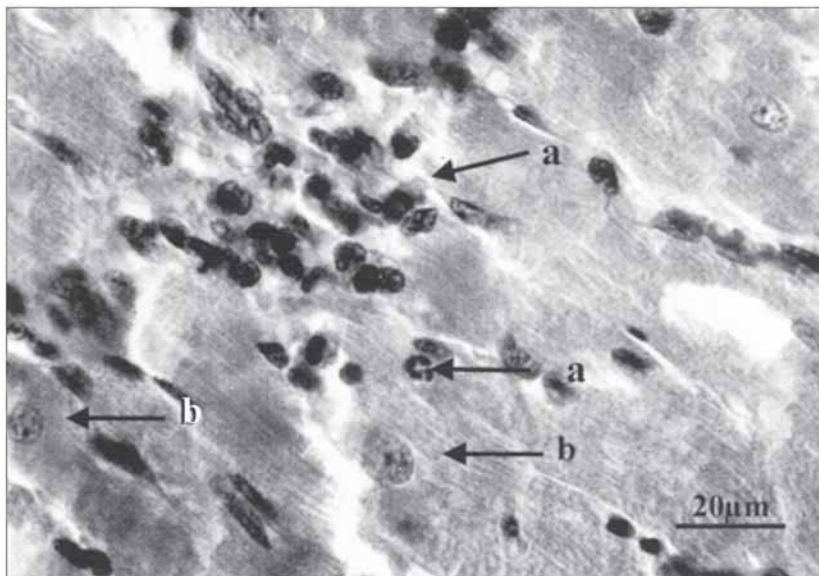


**Fig. 9.** Serum cTnT alterations in rats exposed to 3–5 h of intense exercise;  $p < 0.01$  vs controls;  $p < 0.01$  between groups. (Reproduced from ref. 55.)

increases in cardiac troponin have been reported as follows: ultracyclists with increase in cTnI in 34% of 38 participants (59); 6 of 23 Ironman triathletes, along with abnormalities in their ECG (51); 10% of marathon runners with increases in cTnT and cTnI, evaluated in at least five different studies (6–24 h post race) (56–58,60,62,63); military recruits in arduous training with increases in cTnT (62). Extreme exercise using 3–5 h of forced swimming in a rat model showed substantial increases in cTnT that corresponded with histological evidence of localized myocyte damage (Figs. 9 and 10) (55). However, in human subjects, studies have demonstrated normal postrace quantitative antimyosin myocardial imaging in asymptomatic marathon runners (excluding silent myocardial cell necrosis by imaging), even in the presence of increased cardiac troponin evidence of myocardial cell death (56). Possible mechanisms for the release of cardiac troponin may be global ischemia injury or a more natural turnover of myocardial cells following the stress of running, an issue currently under debate. Long-term risk stratification or outcome studies in these apparently healthy endurance athletes have not been performed.

### NEWBORN INFANTS/PEDIATRICS

cTnT and cTnI concentrations have been described in cord blood and for reference determinations in newborns and pediatric patients (64–67). In one study, 12 of 209 neonates showed increased cTnT levels at the time of delivery. Increases were associated with exposure to magnesium sulfate therapy by the mother prior to birth (68). It has been suggested that infants with respiratory distress at birth had increased cTnT levels (69). In a study of 18 infants, gestational age and birth weight influenced cTnI levels, with preterm infants having higher cTnI values (64). In older pediatric patients (up to 29 mo), cTnI values are generally not increased. However, in the context of severe, acute illness, increased cTnI values were indicators of poor outcomes, especially in cases in which cardiac contusion was suspected (70).



**Fig. 10.** Light microscopic evidence of damaged myocardial fibers and intracellular areas demonstrated by infiltrates of neutrophils, lymphocytes, and histiocytes (a) and vesicular nuclei-enlarged chromatin patterns of left ventricle from a rat subjected to 5 h of swimming (b). (Reproduced from ref. 55.)

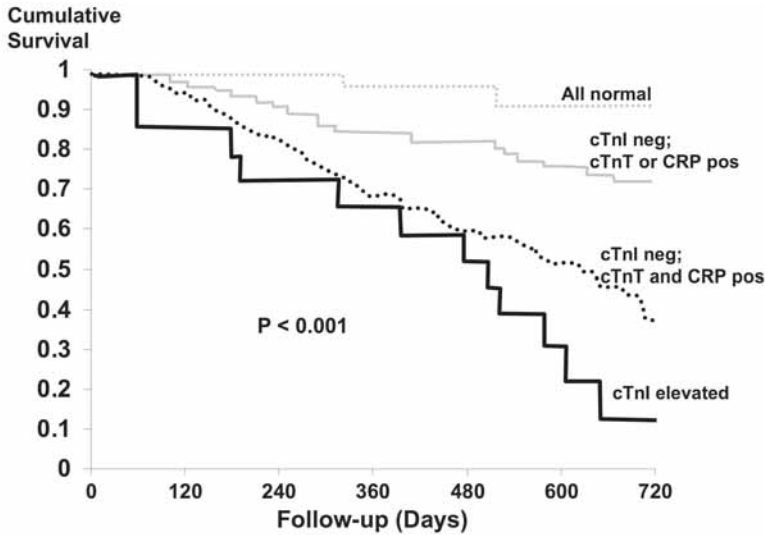
**Table 2**  
Change in Percent LVEF

Month of follow-up	<i>cTnI</i> positive		<i>cTnI</i> negative		No. of echos	<i>p</i> Value
	Mean	SD	Mean	SD		
1	-6.8	10.0	-1.5	8.7	131	0.0003
2	-9.6	8.9	-2.7	8.3	143	<0.0001
3	-11.3	9.8	-2.5	9.0	110	<0.0001
4	-13.6	10.1	-1.5	8.0	135	<0.0001
7	-14.8	10.0	-1.3	8.5	138	<0.0001
12	-18.2	9.8	-2.5	8.6	117	<0.0002

LVEF, left ventricular ejection fraction.

## DRUG-INDUCED MYOCARDIAL DAMAGE

Increases in cardiac troponin have been described in (1) patients treated with certain types of antineoplastic agents, (2) patients presenting to hospitals following alcohol and drug abuse, and (3) patients with therapeutic drug-induced cardiac toxicity. The release of cardiac troponin into the circulation following therapy with antineoplastic agents has been well documented (71–74). Both acute (within hours) and chronic (days to weeks) myocardial toxicity manifested by ischemia, arrhythmias, myocarditis, pericarditis, cardiomyopathy, and/or MI after dosing with the anthracyclines 5-fluorouracil, doxorubicin, and daunorubicin have been associated with minimal and large increases in cTnI. Reports have documented that a medication dose-dependent pattern of myocyte injury is responsible for increases in troponin, even without electrocardiographic or echocardiographic abnormalities. Studies have shown that in patients undergoing high-dose chemotherapy, an increase in cardiac troponin predicts the development of future left ventricular dysfunction (Table 2) (73).



**Fig. 11.** Kaplan-Meier survival curves by baseline cTnT, cTnI, and hsCRP in 399 patients with ESRD. (Reproduced from ref. 106.)

Several drugs of abuse have been associated with increases in cardiac troponin without evidence of ischemia. These include alcohol when heavily consumed (75), cocaine (76, 77), and amphetamines (7). Small clinical studies and case reports have documented increased cardiac troponin concentrations following CO exposure, theophylline overdose, snake bites, and during treatment with fluvastatin (7,78). Two case reports also documented an apparent propofol-induced cardiac and a skeletal muscle rhabdomyolysis; both cases resulting in fatality (79).

## END-STAGE RENAL DISEASE

Cardiac disease is the major cause of death in patients with ESRD, accounting for approx 45% of all deaths (80). In dialysis patients, about 20% of cardiac deaths are attributed to AMI. MI is a catastrophic clinical event in ESRD patients, with a 2-yr mortality of 73%. Increased cardiac death rates in ESRD patients occur more frequently on Mondays and Tuesdays (20%) compared with other days of the week (14%) (81). One challenge confronting the nephrology community is the exploration of more aggressive treatment modalities for cardiovascular disease in these patients.

Serum or plasma cTnT and cTnI are important predictors of long-term, all-cause, and cardiovascular mortality in patients with ESRD (82–107) rather than a spurious finding. Elevations in troponin are associated with higher mortality in outpatient dialysis patients (Fig. 11) (106). For example, elevated cTnT defined by the 99th percentile cutoff is associated with a two- to fourfold increased risk of death over 2 to 3 yr, even following adjustment for other risk factors. It is quite plausible that other mechanisms besides ACS are responsible for the elevation in troponin and adverse outcome, as evidenced by increased C-reactive protein (CRP) and NT-proBNP in these patients (106).

The clinical duality of cardiac troponin testing in dialysis patients must be acknowledged to avoid incorrect clinical judgments; that is, defining ACS and predicting mortality are complementary but discrete tasks. Several studies indicate differences in the observed

rates of increase in cTnT vs cTnI and among different cTnI assays (106). Using the 99th percentile cutoff, 85% ( $n = 339$ ) of cTnT vs only 5–19% ( $n = 20–76$ ; Dade cTnI vs Beckman cTnI assays) of cTnI concentrations were increased. Speculated causes for the difference in increases in cTnT compared with cTnI include the following: First, increased cTnT, but not cTnI, reflects increased left ventricular mass in the population with ESRD; second, the release of cTnT from injured myocardium may have a longer circulating half-life compared with cTnI owing to advanced glycation end products known to accumulate in diabetic patients with renal disease; third, cTnI may decrease postdialysis, either directly, owing to removal by dialysis, or indirectly, by degradation of the labile cTnI molecule. By contrast, cTnT concentrations trend toward an increase postdialysis. In addition, it appears that the Beckman Access cTnI assay detects a larger number of subjects with increased cTnT; this is likely owing to an improved low-end analytic performance of the assay. Additional studies are needed to elucidate the mechanism responsible for the cTnI/cTnT differences found in patients with ESRD. Regardless of the mechanisms of myocardial injury in patients with ESRD, findings continue to substantiate the prognostic relevance of cardiac troponin testing in these patients. Incorporation of quarterly or semiannual cardiac troponin monitoring in patients with ESRD may assist in initiating more aggressive treatment of underlying CAD, detecting subclinical myocardial injury, and choosing treatment therapies before renal transplantation.

### MISCELLANEOUS PATHOLOGIES

New case reports and case series continue to emerge reporting increases in cTnI and/or cTnT in a wide variety of miscellaneous pathologies, indicating secondary myocardial injury. These settings include aneurysmal subarachnoid hemorrhage (108–110), polymyositis/dermatomyositis (111), rhabdomyolysis/skeletal muscle injury not involving the chest (112–114), hematological malignancies (115), acute pericarditis (116–118), and lobar lung disease (119). In one of the most interesting observations, cTnI was preserved through time, with immunoreactivity found in mummified abdominal tissue from Horemkenesi, a craftsman excavating and decorating the tombs of the pharaohs (~1050 BC), who died of a heart attack (120). Two novel reports have described acute and reversible cardiomyopathy provoked by stress in women (designated as “broken heart syndrome”) manifest by acute substernal chest pain with ST-elevation and/or T-wave inversion, absence of significant coronary narrowing, systolic dysfunction, profound psychological stress (death of relatives, arguments, catastrophic medical diagnoses, devastating financial losses), and at least moderate increases in cardiac troponin (cTnT concentrations ranging from  $<0.01$  to  $25.8 \mu\text{g/L}$ ) (121,122). In each case, an acute ischemic mechanism was excluded and the cardiomyopathy was reversible. These cases do not represent all etiologies reportedly documenting increases in cardiac troponin but are representative of the diverse circumstances in which myocardial injury may occur and can now be detected with cardiac troponin. It is thus left up to the clinician to determine the mechanism responsible for the release of cardiac troponin and the appropriate management of the patient, while keeping in mind that increased cardiac troponin equates to irreversible myocardial cell injury, and that in the clinical setting of ischemia, increased troponin should be considered indicative of an MI.

### PREANALYTIC INTERFERENCES

Several factors have been identified as being responsible both for analytic false-positive cardiac troponin findings without the presence of myocardial injury and for false-negative

findings when myocardial injury was present (123). These factors are discussed in detail in Chapter 2 and mentioned briefly here. False-positive cardiac troponin findings may be owing to heterophile antibodies, such as rheumatoid factors, human antianimal antibodies, fibrin clots, microparticles in specimens, and analyzer malfunctions (124–131). Typically, when an assay shows this type of interference, increased cardiac troponin concentrations do not follow the typical serial rising and falling patterns as expected in MI but remain consistently increased over time. When an interferent is suspected, reanalysis of a false-positive specimen utilizing an alternative cTnI or cTnT assay will often correct the inaccuracy. The overall estimated frequency of analytic false positives is likely <1/5000.

## CONCLUSION

Increases in serum or plasma cardiac troponin concentrations indicate myocardial injury in a wide variety of nonischemic presentations. In several of the settings, myocardial injury detectable with cardiac troponin is associated with both short- and long-term adverse outcomes. False-positive and false-negative cardiac troponin results owing to preanalytic and analytic interferences have been reported but are rare in comparison to the frequency of true myocardial injury in clinical settings other than ACS. Clinically, physicians should not manage patients only on the basis of an isolated finding of increased cardiac troponin. In some cases, such as cardiac surgery or radiofrequency ablation, the mechanism of cardiac injury is immediately apparent and is easily distinguished from ACS. In other cases, in which diagnosis is often more difficult, such as myocarditis, the provider must thoughtfully integrate biomarker and other clinical data to arrive at the correct conclusions. Serial monitoring of biomarkers is often very useful in discriminating potential causes of myocardial injury. Further research is needed to determine whether the cut points that are optimal for risk assessment differ among these varied conditions, as well as to ascertain whether such information will add to current strategies for clinical care, and, in particular, whether treatment should be altered on the basis of troponin results.

## REFERENCES

1. Jaffe AS, Ravkilde J, Roberts R, et al. It's time for a change to a troponin standard. *Circulation* 2000; 102:1216–1220.
2. Joint European Society of Cardiology/American College of Cardiology Committee. Myocardial infarction defined—a consensus document of the joint European Society of Cardiology/American College of Cardiology Committee for the redefinition of myocardial infarction. *J Am Coll Cardiol* 2000;36: 959–969.
3. Braunwald E, Antman EM, Beasley JW, et al. ACC/AHA guidelines for the management of patients with unstable angina and non-ST-segment elevation myocardial infarction. *J Am Coll Cardiol* 2000; 36:970–1062.
4. Apple FS, Wu AHB, Jaffe AS. European Society of Cardiology and American College of Cardiology guidelines for redefinition of myocardial infarction: how to use existing assays clinically and for clinical trials. *Am Heart J* 2002;144:981–986.
5. Apple FS. Tissue specificity of cardiac troponin I, cardiac troponin T, and creatine kinase MB. *Clin Chim Acta* 1999;284:151–159.
6. Apple FS, Wu AHB, Valdes R Jr. Serum cardiac troponin T concentrations in hospitalized patients without acute myocardial infarction. *Scand J Clin Lab Invest* 1996;56:63–68.
7. Herman Eugene, Ferrans VJ. The use of cardiac biomarkers for the detection of drug-induced myocardial damage. In: Wu AHB, ed. *Markers in Cardiology*. Humana, Totowa, NJ, 2001, pp. 211–234.
8. Setsuta K, Seino Y, Takahashi N, et al. Clinical significance of elevated levels of cardiac troponin T in patients with chronic heart failure. *Am J Cardiol* 1999;84:608–611.

9. Horwich T, Patel J, MacLellan R, Fonarow G. Cardiac troponin I is associated with impaired hemodynamics, progressive left ventricular dysfunction, and increased mortality rates in advanced heart failure. *Circulation* 2003;108:833–838.
10. Del Carlo C, O'Connor C. Cardiac troponins in congestive heart failure. *Am Heart J* 1999;138:646–653.
11. Vecchia L, Mezzena G, Ometto R, et al. Detectable serum troponin I in patients with heart failure of non-myocardial ischemic origin. *Brief Reports* 1997:88–90.
12. Missov E, Mair J. A novel biochemical approach to congestive heart failure: cardiac troponin T. *Am Heart J* 1999;138:95–99.
13. Mair P, Mair J, Koller J, et al. Cardiac troponin T release in multiply injured patients. *Injury* 1995;26:439–443.
14. Bertinchant J, Polge A, Mohty D, et al. Evaluation of incidence, clinical significance, and prognostic value of circulating cardiac troponin I and T elevation in hemodynamically stable patients with suspected myocardial contusion after blunt chest trauma. *J Trauma Inj Crit Care* 2000;48:824–831.
15. Adams J, Davila-Roman V, Bessey P, et al. Improved detection of cardiac contusion with cardiac troponin I. *Am Heart J* 1996;131:308–312.
16. Mair P, Mair J, Koller J, et al. Cardiac troponin T in the diagnosis of heart contusion. *Lancet* 1991;338:693.
17. Salim A, Velmahos GC, Jindal A, et al. Clinically significant blunt cardiac trauma: role of serum troponin levels combined with electrocardiographic findings. *J Trauma* 2001;50:237–243.
18. Fulda GJ, Giberson F, Hailstone D, Law A, Stillabower M. An evaluation of serum troponin T and signal-averaged electrocardiography in predicting electrocardiographic abnormalities after blunt chest trauma. *J Trauma* 1997;43:304–310.
19. Georges J, Spentchian M, Caubel C, et al. Time course of troponin I, myoglobin, and cardiac enzyme release after electrical cardioversion. *Am J Cardiol* 1996;78:825–827.
20. Runsio M, Kallner A, Kallner G, Rosenqvist M, Bergfeldt L. Myocardial injury after electrical therapy for cardiac arrhythmias assessed by troponin-T release. *Am J Cardiol* 1997;79:1241–1245.
21. Bonnefoy E, Chevalier P, Kirkorian G, et al. Cardiac troponin I does not increase after cardioversion. *Clin Invest Crit Care* 1997;111:15–18.
22. Joglar J, Kessler D, Welch P, et al. Effects of repeated electrical defibrillations on cardiac troponin I levels. *Brief Rep* 1999:270–272.
23. Boriani G, Biffi M, Cervi V, et al. Evaluation of myocardial injury following repeated internal atrial shocks by monitoring serum cardiac troponin I levels. *Clin Invest Crit Care* 2000;118:342–347.
24. Meyer T, Binder L, Hruska N, Luthe H, Buchwald A. Cardiac troponin I elevation in acute pulmonary embolism is associated with right ventricular dysfunction. *J Am Coll Cardiol* 2000;36:1632–1636.
25. Giannitsis E, Muller-Bardorff M, Kuroski V, et al. Independent prognostic value of cardiac troponin T in patients with confirmed pulmonary embolism. *Circulation* 2000;102:211–217.
26. Konstantinides S, Geibel A, Olschewski M, et al. Importance of cardiac troponins I and T in risk stratification of patients with acute pulmonary embolism. *Circulation* 2002;106:1263–1268.
27. Fernandes CJ, Akamine N, Knobel E. Cardiac troponin: a new serum marker of myocardial injury in sepsis. *Intensive Care Med* 1999;25:1165–1168.
28. Ammann P, Fehr T, Minder EI, Gunter C, Bertel O. Elevation of troponin I in sepsis and septic shock. *Intensive Care Med* 2001;27:965–969.
29. Giroir BP, Stromberg D. Myocardial depression versus myocardial destruction: integrating the multiple mechanisms of myocardial dysfunction during sepsis. *Crit Care Med* 2000;28:3111,3112.
30. Spies C, Haude V, Fitzner R, et al. Serum cardiac troponin T as a prognostic marker in early sepsis. *Chest* 1998;113:1055–1063.
31. ver Elst K, Spapen H, Nguyen D, et al. Cardiac troponins I and T are biological markers of left ventricular dysfunction in septic shock. *Clin Chem* 2000;46:650–657.
32. Ammann P, Fehr T, Minder EI, Gunter C, Bertel O. Elevation of troponin I in sepsis and septic shock. *Intensive Care Med* 2001;27:965–969.
33. Wu A. Increased troponin in patients with sepsis and septic shock: myocardial necrosis or reversible myocardial depression? *Intensive Care Med* 2001;27:959–961.
34. Guest T, Ramanathan A, Tuteur P, et al. Myocardial injury in critically ill patients: a frequently unrecognized complication. *JAMA* 1995;273:1945–1949.
35. Kollef M, Ladenson J, Eisenberg P. Clinically recognized cardiac dysfunction: an independent determinant of mortality among critically ill patients: is there a role for serial measurement of cardiac troponin I? *Clin Invest Crit Care* 1997;111:1340–1347.

36. Ammann P, Maggiorini M, Bertel O, et al. Troponin as a risk factor for mortality in critically ill patients without acute coronary syndromes. *J Am Coll Cardiol* 2003;41:2004–2009.
37. Wright R, Williams B, Cramner H, et al. Elevations of cardiac troponin I are associated with increased short-term mortality in non-cardiac critically ill emergency department patients. *Am J Cardiol* 2002;90:634–636.
38. Bachmaier K, Mair J, Offner F, Pummerer C, Neu N. Serum cardiac troponin T and creatine kinase-MB elevations in murine autoimmune myocarditis. *Circulation* 1995;92:1927–1932.
39. Smith S, Ladenson J, Mason J, Jaffe A. Elevations of cardiac troponin I associated with myocarditis. *Circulation* 1997;95:163–168.
40. Lauer B, Niederau C, Kuhl U, et al. Cardiac troponin T in patients with clinically suspected myocarditis. *J Am Coll Cardiol* 1997;30:1354–1359.
41. Franz W, Remppis A, Kandolf R, Kubler W, Katus H. Serum troponin T: diagnostic marker for acute myocarditis. *Clin Chem* 1996;42:340,341.
42. Feldman AM, McNamara D. Myocarditis. *N Engl J Med* 2000;343:1388–1398.
43. James P, Ellis C, Whitlock R, et al. Relation between troponin T concentration and mortality in patients presenting with an acute stroke: observational study. *Br Med J* 2000;320:1502–1504.
44. Ay H, Arsava E, Saribas O. Creatine kinase-MB elevation after stroke is not cardiac in origin: comparison with troponin T levels. *Stroke* 2002;33:286–289.
45. Etgen T, Baum H, Sander K, Sander D. Cardiac troponins and N-terminal pro-brain natriuretic peptide in acute ischemic stroke do not relate to clinical prognosis. *Stroke* 2005;36:270–275.
46. Adams J, Sicard GR, Allen B, et al. Diagnosis of perioperative myocardial infarction with measurement of cardiac troponin I. *N Engl J Med* 1994;330:670–674.
47. Goldman, L. Assessment of peri-operative cardiac risk. *N Engl J Med* 1994;330:707–709.
48. Kim L, Martinez E, Faraday N, et al. Cardiac troponin I predicts short-term mortality in vascular surgery patients. *Am Heart J* 2002;106:2366–2371.
49. Efthimiadis A, Cheiridou M, Lefkos N, et al. The predictive value of troponin T in patients who underwent an extracardiac surgery operation. *Acta Cardiol* 1995;L:309–313.
50. Metzler H, Gries M, Rehak P, et al. Perioperative myocardial cell injury: the role of troponins. *Br J Anaesth* 1997;78:386–390.
51. Rifai N, Douglas PS, O’Toole M, Rimm E, Ginsburg G. Cardiac troponin T and I electrocardiographic wall motion analyses, and ejection fractions in athletes participating in the Hawaii Ironman Triathlon. *Am J Cardiol* 1999;83:1085–1089.
52. Shave R, Dawson E, Whyte G, George K, Gaze D, Collinson P. Altered cardiac function and minimal cardiac damage during prolonged exercise. *Med Sci Sports Exerc* 2004;36:1098–1103.
53. Apple FS, Rhodes MD. Enzymatic estimation of skeletal muscle damage by analysis of changes in serum creatine kinase. *J Appl Physiol* 1988;65:2598–2600.
54. Siegel AJ, Stec JJ, Lipinska I, et al. Effect of marathon running on inflammatory and hemostatic markers. *Am J Cardiol* 2001;88:918–920.
55. Chen Y, Serfass RC, Mackey-Bojack S, Kelly KL, Titus JL, Apple FS. Cardiac troponin T alterations in myocardium and serum of rats following stressful, prolonged intense exercise *J Appl Physiol* 2000;88:1749–1755.
56. Siegel AJ, Kewandroski KB, Strauss W, Fischman AJ, Yasuda T. Normal post-race antimyosin myocardial scintigraphy in asymptomatic marathon runners with elevated serum creatine kinase MB isoenzyme and troponin T levels. *Cardiology* 1995;86:451–456.
57. Cummins P, Young A, Auckland ML, Michie CA, Stone PCW, Shepstone BJ. Comparison of serum cardiac specific troponin-I with creatine kinase, creatine kinase-MB isoenzyme, tropomyosin, myoglobin and C-reactive protein release in marathon runners: cardiac or skeletal muscle trauma? *Eur J Clin Invest* 1987;17:317–324.
58. Laslett L, Eisenbud E. Lack of detection of myocardial injury during competitive races of 100 miles lasting 18 to 30 hours. *Am J Cardiol* 1997;80:379–380.
59. Adams JE, Bodor GS, Davila-Roman VG, et al. Cardiac troponin I: a high marker with high specificity for cardiac injury. *Circulation* 1993;88:101–106.
60. Soricter S, Mair J, Koller A, et al. Skeletal muscle troponin I release and magnetic resonance imaging signal intensity changes after eccentric exercise-induced skeletal muscle injury. *Clin Chim Acta* 1997;262:139–146.
61. Collinson PO, Chandler HA, Stubbs PJ, Moseley DS, Lewis D, Simmons MD. Measurement of serum troponin T, creatine kinase MB isoenzyme, and total creatine kinase following arduous physical training. *Ann Clin Biochem* 1995;32:1–4.

62. Apple FS, Rogers MA, Sherman WM, Casal DC, Ivy JL. Creatine kinase MB isoenzyme adaptations in stressed human skeletal muscle. *J Appl Physiol* 1985;59:149–153.
63. Apple FS, Rogers MA, Casal DC, Lewis L, Ivy JL, Lampe JW. Skeletal muscle creatine kinase MB alterations in women marathon runners. *Eur J Appl Physiol* 1987;56:49–52.
64. Quivers E, Murthy J, Soldin S. The effect of gestational age, birth weight and disease on troponin I and creatine kinase MB in the first year of life. *Clin Biochem* 1999;32:419–421.
65. Shelton S, Fouse B, Holleman V, Sedor F, Herbert W. Cardiac troponin T levels in umbilical cord blood. *Am J Obstet Gynecol* 1999;181:1259–1262.
66. Hirsch R, Landt Y, Porter S, et al. Cardiac troponin I in pediatrics: normal values and potential use in the assessment of cardiac injury. *J Pediatr* 1997;130:872–877.
67. Adamcova M, Kokstein Z, Palicka V, Podholova M, Kostal M. Troponin T levels in the cord blood of healthy term neonates. *Physiology* 1995;44:99–104.
68. Shivvers S, Wians F Jr, Keffer J, Ramin S. Maternal cardiac troponin levels during normal labor and delivery. *Am J Obstet Gynecol* 1999;180:122.
69. Clark SJ, Newland P, Yoxall CW, Subhedar NV. Cardiac troponin T in cord blood. *Arch Dis Child Fetal Neonatal Ed* 2001;84:F34–F37.
70. Immer F, Stocker F, Seiler A, et al. Troponin-I for prediction of early post-operative course after pediatric cardiac surgery. *J Am Coll Cardiol* 1999;33:1719–1723.
71. Ganz W, Sridhar K, Ganz D, et al. Review of tests for monitoring doxorubicin-induced cardiomyopathy. *Oncology* 1996;53:461–470.
72. Herman E, Lipshultz S, Rifai N, et al. Use of cardiac troponin T levels as an indicator of doxorubicin-induced cardiotoxicity. *Cancer Res* 1998;58:195–197.
73. Cardinale D, Sandri M, Martinoni A, et al. Left ventricular dysfunction predicted by early troponin I release after high-dose chemotherapy. *J Am Coll Cardiol* 2000;36:517–522.
74. Sandri MT, Cardinale D, Zorzino L, et al. Minor increases in plasma troponin I predict decreased left ventricular ejection fraction after high-dose chemotherapy. *Clin Chem* 2003;49:248–252.
75. Patel V, Ajmal R, Sherwood R, et al. Cardioprotective effect of propranolol from alcohol-induced heart muscle damage as assessed by plasma cardiac troponin-T. *Alcohol Clin Exp Res* 2001;25:882–889.
76. McLaurin M, Apple FS, Henry TD, Sharkey SW. Cardiac troponin I and T levels in patients with cocaine associated chest pain. *Ann Clin Biochem* 1996;33:183–186.
77. Kushman S, Storrow A, Liu T, Gibler B. Cocaine-associated chest pain in a chest pain center. *Am J Cardiol* 2000;85:394–396.
78. Benghozi R, Bortolini M, Jia Y, et al. Frequency of creatine kinase elevation during treatment with fluvastatin. *Am J Cardiol* 2002;89:231–233.
79. Stelow R, Johari V, Smith S, Crosson J, Apple FS. Propofol-associated rhabdomyolysis with cardiac involvement in adults: chemical and anatomic findings. *Clin Chem* 2000;46:577–581.
80. Herzog CA, Ma JZ, Collings AJ. Poor long-term survival after acute myocardial infarction among patients on long-term dialysis. *N Engl J Med* 1998;339:779–805.
81. Bleyer AJ, Russell GB, Satko SG. Sudden and cardiac death rates in hemodialysis patients. *Kidney International* 1999;55:1553–1559.
82. Lente F, McErlean E, DeLuca S, et al. Ability of troponins to predict adverse outcomes in patients with renal insufficiency and suspected acute coronary syndromes: a case-matched study. *J Am Coll Cardiol* 1999;33:471–478.
83. Ooi D, Zimmerman D, Graham J, Wells G. Cardiac troponin T predicts long-term outcomes in hemodialysis patients. *Clin Chem* 2001;47:412–417.
84. McCullough P, Nowak R, Foreback C, et al. Performance of multiple cardiac biomarkers measured in the emergency department in patients with chronic kidney disease and chest pain. *Acad Emerg Med* 2002;9:1389–1396.
85. Iliou M, Fumeron C, Benoit M, et al. Factors associated with increased serum levels of cardiac troponins T and I in chronic haemodialysis patients: chronic haemodialysis and new cardiac markers evaluation (CHANCE) study. *Nephrol Dial Transplant* 2001;16:1452–1458.
86. Porter GA, Norton T, Bennett WM. Long-term follow-up of the utility of troponin T to assess cardiac risk in stable chronic hemodialysis patients. *Clin Lab* 2000;46:469–476.
87. Dierkes J, Domrose U, Westphal D, et al. Cardiac troponin T predicts mortality in patients with end-stage renal disease. *J Am Coll Cardiol* 2000;102:1964–1969.
88. Aviles R, Askari A, Lindahl B, et al. Troponin T levels in patients with acute coronary syndromes, with or without renal dysfunction. *N Engl J Med* 2002;346:2047–2052, 2079–2082.



89. Lowbeer C, Ottosson-Seeberger A, Gustafsson S, et al. Increased cardiac troponin T and endothelin-1 concentrations in dialysis patients may indicate heart disease. *Nephrol Dial Transplant* 1999;14:1948–1955.
90. Roppolo L, Fitzgerald R, Dillow J, et al. A comparison of troponin T and troponin I as predictors of cardiac events in patients undergoing chronic dialysis at a veteran's hospital: a pilot study. *J Am Coll Cardiol* 1999;34:448–454.
91. Khan I, Wattanasuwan N, Mehta N, et al. Prognostic value of serum cardiac troponin I in ambulatory patients with chronic renal failure undergoing long-term hemodialysis. *J Am Coll Cardiol* 2001;38:991–998.
92. Jaffe S. Editorial comment: testing the wrong hypothesis: the failure to recognize the limitations of troponin assays. *J Am Coll Cardiol* 2001;38:999–1001.
93. McLaurin M, Apple FS, Falahati A, et al. Cardiac troponin I and creatine kinase-MB mass to rule out myocardial injury in hospitalized patients with renal insufficiency. *Am J Cardiol* 1998;82:973–975.
94. Mockel M, Schindler R, Knorr L, et al. Prognostic value of cardiac troponin T and I elevations in renal disease patients without acute coronary syndromes: a 9-month outcome analysis. *Nephrol Dial Transplant* 1999;14:1489–1495.
95. Haller C, Zehelein J, Remppis S, Muller-Bardorff M, Katus H. Cardiac troponin T in patients with end-stage renal disease: absence of expression in truncal skeletal muscle. *Clin Chem* 1998;44:930–938.
96. Apple FS, Sharkey S, Hoelt P, et al. Prognostic value of serum cardiac troponin I and T in chronic dialysis patients: a 1-year outcomes analysis. *Am J Kidney Dis* 1997;29:399–403.
97. McLaurin M, Apple FS, Voss E, Herzog C, Sharkey S. Cardiac troponin I, cardiac troponin T, and creatine kinase MB in dialysis patients without ischemic heart disease: evidence of cardiac troponin T expression in skeletal muscle. *Clin Chem* 1997;43:976–982.
98. Ishii J, Ishikawa T, Yuki take J, et al. Clinical specificity of a second-generation cardiac troponin T assay in patients with chronic renal failure. *Clin Chim Acta* 1998;270:183–188.
99. Frankel W, Herold D, Ziegler T, Fitzgerald R. Cardiac troponin T is elevated in asymptomatic patients with chronic renal failure. *Clin Chem* 1995;106:118–123.
100. Ellis K, Dreisbach A, Lertora J. Plasma elimination of cardiac troponin I in end-stage renal disease. *South Med J* 2001;94:993–996.
101. Apple FS, Murakami MA, Pearce L, Herzog C. Predictive value of cardiac troponin I and T for subsequent death in end-stage renal disease. *Circulation* 2002;294:2941–2945.
102. Hamm C, Giannitsis E, Katus H. Cardiac troponin elevations in patients without acute coronary syndrome. *Circulation* 2002;287:2871,2872.
103. Roberts MA, Fernando D, Macmillan N, et al. Single and serial measurements of cardiac troponin I in asymptomatic patients of chronic hemodialysis. *Clin Nephrol* 2004;61:40–46.
104. Diris J, Hackeng C, Kooman J, et al. Impaired renal clearance explains elevated troponin T fragments in hemodialysis patients. *Circulation* 2004;23–25.
105. Donnino M, Karriem-Norwood V, Rivers E, et al. Prevalence of elevated troponin I in end-stage renal disease patients receiving hemodialysis. *Acad Emerg Med* 2004;11:979–981.
106. Apple FS, Murakami MA, Pearce L, Herzog C. Multi-biomarker risk stratification on N-terminal pro-B-type natriuretic peptide, high-sensitivity C-reactive protein, and cardiac troponin T and I in end-stage renal disease for all-cause death. *Clin Chem* 2004;50:1–7.
107. deFilippi C, Wasserman S, Rosanio S, et al. Cardiac troponin T and C-reactive protein for predicting prognosis, coronary atherosclerosis, and cardiomyopathy in patients undergoing long-term hemodialysis. *JAMA* 2003;290:353–359.
108. Parekh N, Venkatesh B, Cross D, et al. Cardiac troponin I predicts myocardial dysfunction in aneurysmal subarachnoid hemorrhage. *J Am Coll Cardiol* 2000;36:1328–1335.
109. Horowitz MB, Willet D, Keffer J. The use of cardiac troponin-I (cTnI) to determine the incidence of myocardial ischemia and injury in patients with aneurysmal and presumed aneurysmal subarachnoid hemorrhage. *Acta Neurochir (Wien)* 1998;140:87–93.
110. Deibert E, Aiyagari V, Diringner MN. Reversible left ventricular dysfunction associated with raised troponin I after subarachnoid hemorrhage does not preclude successful heart transplantation. *Heart* 2000;84:205–207.
111. Kobayashi S, Tanaka M, Tamura N, Hashimoto H, Hirose S. Serum cardiac troponin T in polymyositis/dermatomyositis. *Lancet* 1992;340:726.
112. Lavoine A, Hue G. Serum cardiac troponins I and T in early post-traumatic rhabdomyolysis. *Clin Chem* 1998;44:667–681.

113. Lofberg M, Tahtela R, Harkonen M, Somer H. Cardiac troponins in severe rhabdomyolysis. *Clin Chem* 1996;42:1120,1121.
114. Benoist J, Cosson C, Mimoz O, Edouard A. Serum cardiac troponin I, creatine kinase (CK), and CK-MB in early post-traumatic rhabdomyolysis. *Clin Chem* 1997;43:416,417.
115. Missov E, Calzolari C, Davy J, et al. Cardiac troponin I in patients with hematologic malignancies. *Coron Artery Dis* 1997;8:537–541.
116. Bonnefoy E, Godon P, Kirkorian G, et al. Serum cardiac troponin I and ST-segment elevation in patients with acute pericarditis. *Eur Heart J* 2000;21:832–836.
117. Brandt R, Filzmaier K, Hanrath P. Circulating cardiac troponin I in acute pericarditis. *Am J Cardiol* 2001;87:1326–1328.
118. Cina S, Thompson W, Fischer J, et al. A study of various morphologic variables and troponin I in pericardial fluid as possible discriminators of sudden cardiac death. *Am J Forensic Med Pathol* 1999;20:333–337.
119. Weinberg I, Cukierman T, Chajek-Shaul T. Troponin T elevation in lobar lung disease. *Postgrad Med J* 2002;78:244,245.
120. Miller R, Callas DD, Kahn SE, Ricchiuti V, Apple FS. Evidence of myocardial damage in mummified human tissue. *JAMA* 2000;284:831,832.
121. Sharkey SW, Lesser JR, Zenovich AG, et al. Acute and reversible cardiomyopathy provoked by stress in women from the United States. *Circulation* 2005;111:472–479.
122. Wittstein IS, Thieman DR, Lima JAC, et al. Neurohumoral features of myocardial stunning due to sudden emotional stress. *N Engl J Med* 2005;352:539–548.
123. Katrukha A, Bereznikova A, Filatov V, Esakova T. Biochemical factors influencing measurement of cardiac troponin I in serum. *Clin Chem Lab Med* 1999;37:1091–1095.
124. Parry D, Krahn J, Leroux M, Dalton J. False-positive analytical interference of cardiac troponin I assays: an important consideration for method selection. *Clin Biochem* 1999;32:667–669.
125. Dasgupta A, Banerjee S, Datta P. False-positive troponin I in the MEIA due to the presence of rheumatoid factors in serum—elimination of this interference by using a polyclonal antisera against rheumatoid factors. *Am J Clin Pathol* 1999;112:753–756.
126. McClennen S, Halamka J, Horowitz G, Kannam J, Ho K. Clinical prevalence and ramifications of false-positive cardiac troponin I elevations from the Abbott AxSYM analyser. *Am J Cardiol* 2003;91:1125–1127.
127. Yeo K, Storm C, Li Y, et al. Performance of the enhanced Abbott AxSYM cardiac troponin I reagent in patients with heterophilic antibodies. *Clin Chim Acta* 2000;292:13–23.
128. Bohner J, Pape K, Hannes W, Stegmann T. False-negative immunoassay results for cardiac troponin I probably due to circulating troponin I autoantibodies. *Clin Chem* 1996;42:2046.
129. Krahn J, Parry D, Leroux M, Dalton J. High percentage of false-positive cardiac troponin I results in patients with rheumatoid factor. *Clin Biochem* 1999;32:477–480.
130. Fitzmaurice T, Brown C, Rifai N, Wu A, Yeo K. False increase of cardiac troponin I with heterophilic antibodies. *Clin Chem* 1998;44:2212–2214.
131. Nosanchuk J. False increases of troponin I attributable to incomplete separation of serum. *Clin Chem* 1999;45:714.



# 11

---

## Degradation of Cardiac Troponins

### *Implications for Clinical Practice*

---

*Allan S. Jaffe, MD*  
*and Jennifer E. Van Eyk, PhD*

#### **CONTENTS**

INTRODUCTION
PHYSIOLOGICAL AND PATHOLOGICAL STATUS OF TROPONIN IN HEART
POTENTIAL FOR DIFFERENT FRAGMENTS FOR DIFFERENT
PATHOPHYSIOLOGICAL PROCESSES
POTENTIAL OF FRAGMENT ANALYSIS
POTENTIAL BIOLOGICAL EFFECTS
CONCLUSION
REFERENCES

---

#### **SUMMARY**

The use of highly sensitive and very specific measurements of cardiac troponin I and troponin T has revolutionized the detection of cardiac injury. Although the most common use of these tests is the diagnosis of acute myocardial infarction, it has become clear that there are a large number of other disease entities capable of causing troponin release. The process of supply/demand imbalance is a part of many of these other pathophysiologies and, therefore, could, in one sense, be considered ischemia. This suggests that the cardiac myocyte is sensitive to a variety of pathological stresses on the cardiopulmonary system. It is feasible that these stresses are reflected in the posttranslational degradation and disease-specific processing of the troponins within the myocyte prior to release into the blood. To further facilitate and improve the diagnostic yield of the cardiac troponins, one can increase the sensitivity of the assays to allow for detection of still lower levels. Another possibility is to determine whether or not there is the potential to detect specific cardiac troponin fragments, with the idea that they might be more specific for the certain types of cardiac injury and thus specific disease processes. This chapter discusses potential disease-related degradation; why there might be different fragments for different pathological processes; and, finally, the potential clinical use in monitoring these modifications. The attempt to distinguish disease entities based on fragment analysis has the potential to further advance the field by allowing more specific diagnoses.

**Key Words:** Cardiac troponin; degradation; disease-induced modification; ischemia.

From: *Contemporary Cardiology:*  
*Cardiovascular Biomarkers: Pathophysiology and Disease Management*  
Edited by: David A. Morrow © Humana Press Inc., Totowa, NJ

## INTRODUCTION

The use of highly sensitive and nearly totally specific measurements of cardiac troponin I (cTnI) and cardiac troponin T (cTnT) has revolutionized the ability to detect cardiac injury. These proteins, which participate in a regulation of the myosin-actin interaction, have been known for many years (1). In the late 1970s, Cummins and Perry (2) developed the first serum-based assay predicated on polyclonal antibodies. Subsequently, while exploring the possibility of increased specificity with some of the myosin light-chain fragments, Hugo Katus, in Germany, determined that cTnT appeared to have unique specificity for myocardium (3). Subsequently, Bodor et al. (4), working at Washington University, made similar observations when they developed antibodies against cTnI. Subsequent studies have confirmed the fact that these proteins are the products of unique genes, and that when appropriate antibody pairs are used for detection, measurements of these analytes have nearly perfect specificity for the heart (5).

There was some difficulty initially with the antibodies used for the cTnT assay, which also detected some reexpressed fetal cTnT fragments that can exist in response to injury in the skeletal muscle (6). However, the present antibodies have been shown to correct that problem (7,8), and there is nearly total cardiac specificity with either cTnT or cTnI. For this reason and because they are far more sensitive than previously used markers such as creatine kinase-MB (CK-MB), these biomarkers have become the “gold standard” for the diagnosis of cardiac injury (9,10). This advance underlies a conceptual move in diagnostics toward the use of organ-specific isoforms to achieve a high level of specificity for organ damage. However, there is yet another level that may be made possible by understanding the unique forms that are released and/or evolve after specific pathophysiological insults.

The most common use for the cardiac troponin (cTnI and/or cTnT) is in the diagnosis of cardiac injury induced by acute ischemia. A variety of studies have confirmed that any elevation in cardiac troponin is indicative of cardiac injury and, therefore, fulfills criteria in the appropriate clinical setting for the diagnosis of acute myocardial infarction (AMI) (9,10). Prognostically, such elevations have been associated with an adverse prognosis in patients who present with ischemic heart disease (11). To date, even the most minor increases in troponin observed in the blood in patients who present with acute coronary ischemia are associated with an adverse prognosis. Furthermore, such elevations have therapeutic implications in most, if not all, studies (12).

However, there are a multiplicity of other disease entities that also cause the release of troponin (13). Many of these include common entities such as acute heart failure, pulmonary embolism, and perhaps less common diseases such as myocarditis. The injurious processes in each of these circumstances are different, but it appears that elevations, no matter how modest, are associated with evidence of a pathophysiologically significant clinical process associated with an adverse clinical prognosis. This relationship is not surprising if one views each of these disease entities as a continuum in which those that are more severe are more apt to have damage to cardiomyocytes, and carry a more adverse prognosis over time. This observation has led to a variety of suggestions for risk stratification and perhaps the therapeutic interventions predicated on elevations in troponin (12).

As we began to interrogate patients in a variety of clinical settings, it became quite clear that the diseases capable of damaging the heart are varied with diverse pathophysiology that all can result in troponin release (13). Many of them have as part of their patho-

physiology supply–demand imbalance and, therefore, might be considered ischemia in one sense. However, in many of these situations, there need not be coronary abnormalities, as are characteristic of patients with acute coronary syndromes (ACSs). Moreover, given that the stimulus to cardiac injury may be different, these varied conditions may well induce different changes in the biochemical markers of myocardial injury. The high degree of sensitivity, specificity, and predictive value of troponin elevations makes the differential diagnosis in many patients far more critical, and we are just starting to appreciate how widely troponin measurements should/can be applied. For example, critically ill patients who have elevations of troponin are at markedly increased risk of subsequent events (14, 15). Such observations suggest that the heart, specifically the cardiac myocytes, is very sensitive to the physiological environment of the cardiopulmonary system. Thus, pathological changes in any aspect of this system can adversely affect the health of the myocyte and may be reflected by the release of troponin and its subsequent detection in blood.

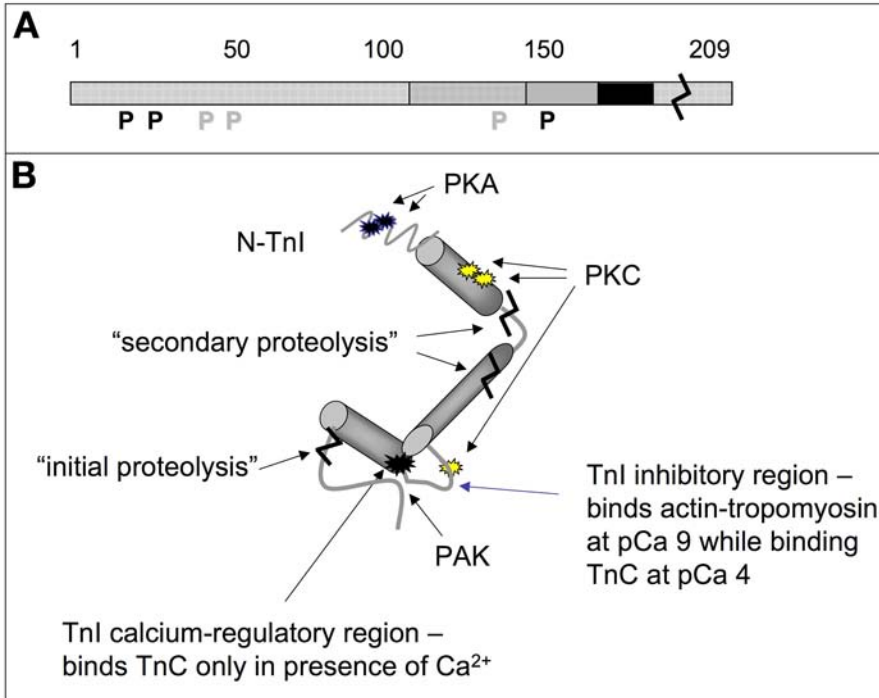
The question posed by many researchers is, How can the diagnostic yield of the cardiac troponins be further facilitated and improved? In other words, how can the clinical utility of the troponin assay be maximized? Two strategies have been suggested. One is to improve the sensitivity of the assays to allow detection of still lower levels with the hope that that will allow still better diagnosis and prognostic classification. Alternatively, one could determine whether or not there is the potential to detect specific cardiac troponin fragments with the idea that they might be more specific for the certain types of cardiac injury and thus specific disease processes. The present review is oriented toward exploring the latter hypothesis.

## PHYSIOLOGICAL AND PATHOLOGICAL STATUS OF TROPONIN IN HEART

### *Physiological Action of Troponins I, T, and C*

Troponin comprises three subunits, troponin I, troponin T, and troponin C, which work in concert with tropomyosin and filamentous actin (thin filament) in a highly cooperative manner to control and regulate striated muscle (skeletal and cardiac) contraction. Contraction occurs through the calcium-dependent interaction of the thin and thick filament (primarily composed of myosin) (16–20). In diastole, at reduced cellular calcium concentration, there is a low probability of interaction between the thick and thin filament and, as such, force production is low and the muscle is relaxed. With systole, calcium floods the cell, inducing a complex series of conformational changes within the troponin complex, ultimately promoting the interaction between actin and myosin (thin and thick filament) and resulting in force.

The troponin subunits each play a unique functional role (16–20). cTnT is named for its ability to anchor troponin onto the actin-tropomyosin thin filament through a number of  $\text{Ca}^{2+}$ -dependent and  $\text{Ca}^{2+}$ -independent interactions. cTnC is the  $\text{Ca}^{2+}$  sensor. The binding of an additional calcium to troponin C during systole alters its conformation and interaction with cTnI, initiating the  $\text{Ca}^{2+}$ -dependent signal to the rest of the thin filament. cTnI acts as a switch, turning muscle contraction on and off. Contraction occurs when cTnC binds the regulatory calcium, allowing the  $\text{Ca}^{2+}$ -regulatory region of cTnI to bind cTnC. This initial interaction pulls over the cTnI inhibitory region from its sites on actin-tropomyosin toward cTnC, promoting a cascade of conformational changes throughout the thick and thin filaments that allows actin and myosin to interact (Fig. 1).



**Fig. 1.** Schematic representation of human cTnI. (A) Representation of linear amino acid sequence of human cTnI (residues 1–209). Important biological regions are shown: the troponin I (TnI) inhibitory region (▣); the troponin I calcium-regulatory region (■); and a region to the C-terminus that binds actin-tropomyosin (■), which anchors the troponin I molecule in place. Phosphorylation sites for protein kinase A (PKA), PKC, and p21-activated kinase (PAK) are shown as P. The zigzag points to the C-terminal cleavage site that occurs with global ischemia in isolated rat hearts. (B) Schematic of troponin I (modified from ref. 18) showing various regions just described including secondary cleavage sites shown to occur in isolated rat hearts with more severe ischemia.

### *Phosphorylation and Proteolysis of Troponin*

The action of each troponin subunit is regulated through extensive interactions with each other and actin-tropomyosin. Likely to ensure that the complex remains associated under most conditions, some of these protein–protein interactions are extremely strong. Others are less tight and are primarily involved in the regulation of the troponin and thin filament response to changes in the cellular calcium concentration. Like most important cellular regulators, cTnI is under tight regulatory control, primarily through signaling pathways that ultimately lead to phosphorylation of specific serine and threonine residues. Although many different kinases (PKC and PAK) have been shown to be able to phosphorylate cTnI (and cTnT) *in vitro*, only PKA phosphorylation has been shown to occur *in vivo* (20) (Fig. 1). PKA is stimulated in response to physiological  $\beta$ -adrenergic stimulation, which also results in the phosphorylation of numerous other important calcium-response proteins such as phospholamban and the ryanodine receptor (21). The extent of cTnI and cTnT phosphorylation is affected by two factors: the individual activity of the kinase and phosphatase and the accessibility of the potential phosphoamino acid. The latter is primarily dependent on the conformation of the protein and, hence, the cellular calcium concentration as well as the presence and local influence of any other posttranslational modification.

<b>Physiological Modification</b>	<p><b>Phosphorylation</b></p> <ul style="list-style-type: none"> <li>- PKA (increased levels)</li> </ul> <p><b>Degradation</b></p> <ul style="list-style-type: none"> <li>- N-terminus (starting at 27, 28 or 31)</li> </ul>
<b>Pathological Modification</b>	<p><b>Phosphorylation</b></p> <ul style="list-style-type: none"> <li>- PKA (reduced levels)</li> <li>- protein kinase C</li> <li>- p21 activated kinase</li> </ul> <p><b>Degradation</b></p> <ul style="list-style-type: none"> <li>- C-terminus (ending at 192)</li> <li>- N-terminus (starting at 63)</li> <li>- N-terminus (starting at 73)</li> </ul>

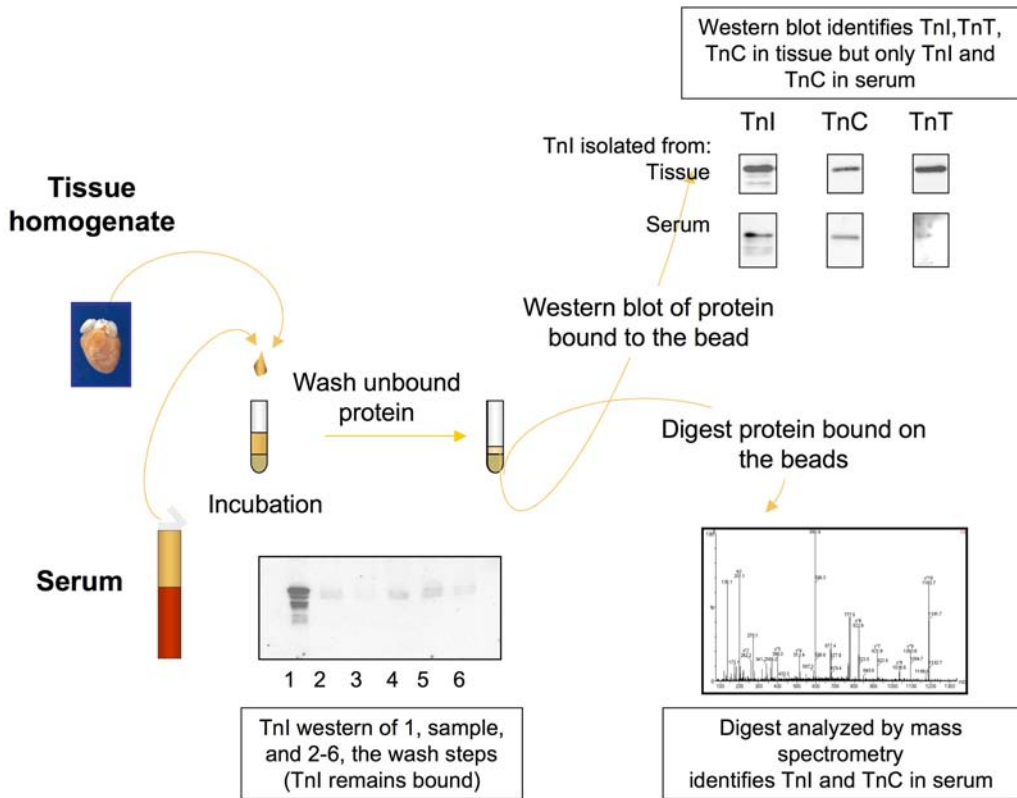
**Fig. 2.** Potential different posttranslational modified forms to troponin I that may occur under physiological and pathological conditions.

Further diversity can arise when cTnI and/or cTnT undergoes specific and selective pathological proteolysis with ischemia (19,20,22). The proteolysis in human heart was initially speculated from a series of experiments on isolated rat hearts that underwent global ischemia (17,18,20,22). There is an initial C-terminal proteolysis of cTnI followed by two N-terminal proteolysis cleavages that subsequently occur with increasing degree (severity) of ischemia. Although not present in larger animals (dogs and pigs), it is clear that proteolysis of cTnI does occur in human hearts (more detail in a later section). These modifications of the troponins could give rise to a dizzying number of phosphorylated and degraded species of cTnI and cTnT. Confirmation of this diversity is currently lacking, primarily owing to the lack of tools capable of assessing and monitoring the phosphorylation and degradation status of each amino acid residue in a robust and high-throughput manner. Even so, this combination of physiological and pathological posttranslational modifications, each of which gives important information about the function of the contractile apparatus, has the potential to become the next level of diagnostics (Fig. 2).

### *Aggregation of Troponin Subunits*

Several intrinsic characteristics of cTnI govern, at least in part, the form of this molecule that is present in the serum. As mentioned, the interactions between cTnI and the other troponin subunits in the myocyte can be extremely tight and require harsh denaturing conditions (8 M urea and 1 M salt) to dissociate into dimers or monomers. These strong interactions make it difficult for the intact molecules to be released from one another. As well, cTnI and cTnT are essentially insoluble as monomers and aggregate at neutral pH. Both molecules have enhanced solubility when bound to each other or to cTnC. Furthermore, because of its high pI (9.5), resulting from its large number of positively charged amino acid residues, cTnI is “sticky” and will bind to negatively charged proteins (e.g., troponin C). cTnT, although having a more neutral pI (~5.0), is also “sticky,” owing to its charge distribution, which is clustered. The N-terminus of cTnT is predominately acidic with many

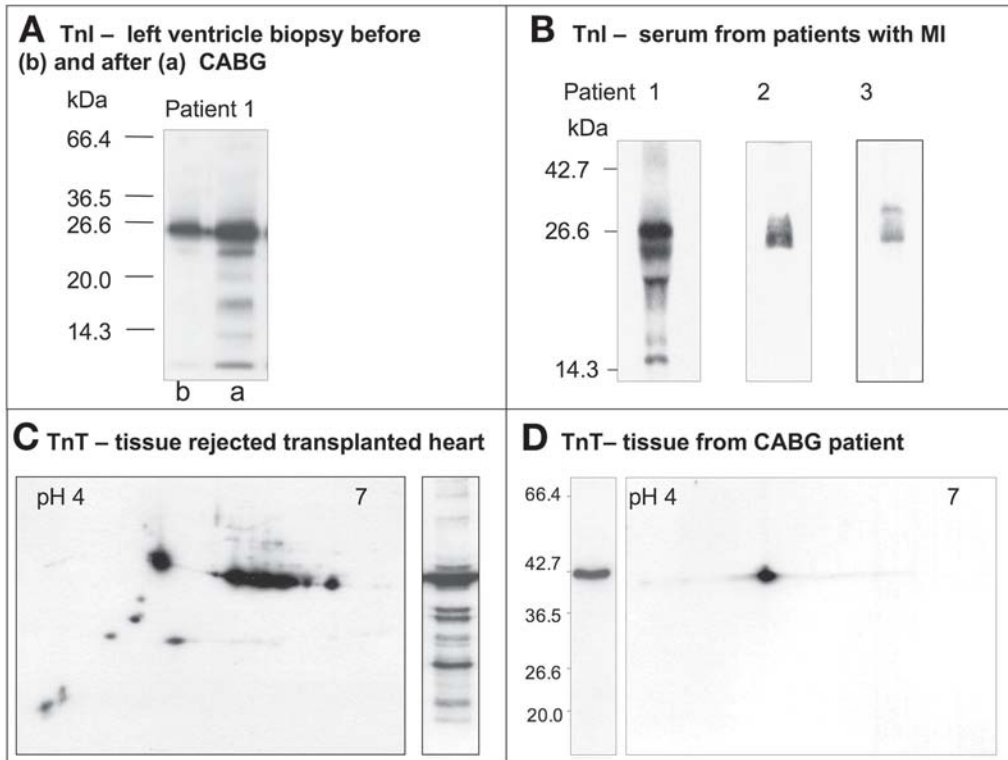




**Fig. 3.** Schematic of cTnI complex isolation from tissue and serum of patient who underwent coronary artery bypass graft (CABG). Either tissue homogenate or serum was incubated with an anti-cTnI antibody covalently coupled to beads. The beads were extensively washed to remove any unbound and nonspecifically bound protein. This can be seen in the Western blot (lane 1, sample loaded [serum]; lanes 2–6, wash steps), where there is minimal cTnI eluted. The majority of the cTnI remained bound to the antibody-bead. An aliquot of the bead (cTnI complex-antibody-bead) was boiled and run on sodium dodecyl sulfate-polyacrylamide gel electrophoresis (SDS-PAGE) and Western blotted for the three troponin subunits. In tissue, all three subunits were observed with equal quantity. In serum, primarily cTnI and cTnC were observed, indicating that cTnI is either a monomer or bound to cTnC in serum. Protein identification was confirmed by digesting the remaining aliquot of the bead (cTnI complex-antibody-bead) and analyzed by matrix-assisted laser desorption ionization time-of-flight mass spectrometry. In tissue, all three troponin subunits were identified, whereas peptide fragments of only cTnI and cTnC were observed in sample isolated from serum (*see ref. 25* for more details).

negatively charged amino acid residues whereas the C-terminal portion of the molecule is basic and contains mainly positively charged amino acids.

These properties indicate, especially for cTnI, that these molecules will most likely not be found as monomers in the serum but, rather, bound to one or both of the other cardiac troponin subunits or to other serum protein(s). Data from the literature support this assumption and have demonstrated indirectly that cTnI in the serum is most likely complexed predominately with cTnC (23,24). Using an anti-troponin I antibody, our laboratory (25) captured cTnI-containing complexes from the serum of patients with AMI and proved directly that cTnI is bound to cTnC in serum (Fig. 3). However, it is not always the case that these two subunits are bound. It is important to recognize that the phosphorylation and degradation status of cTnI can dramatically alter the affinity of cTnI for cTnC.



**Fig. 4.** Representative Western blots of cTnI and cTnT from human myocardium or serum. **(A)** One-dimensional SDS-PAGE (12%) Western blot of cTnI of biopsy obtained from patient undergoing CABG taken from left ventricle in area remote to ischemic region before surgery and after cross-clamp removal. **(B)** One-dimensional SDS-PAGE (12%) Western blot of cTnI serum obtained from three different patients with AMI diagnosed using clinical parameters and elevated serum troponin I based on clinical chemistry assay. **(C,D)** One-dimensional SDS-PAGE (12%) and two-dimensional gel electrophoresis (pI 4–7; 12% SDS-PAGE) Western blot of cTnT from left ventricle tissue obtained from transplanted heart rejected by recipient **(C)** or biopsy obtained from patient who underwent CABG **(D)**.

For example, truncation of the N-terminus (which can occur with ischemia [secondary site in Fig. 1]) will remove both PKA phosphorylation sites and a major cTnI-cTnC binding site, greatly reducing the affinity between the modified cTnI and cTnC. In this case, the circulating modified form of cTnI most likely will be bound to other positively charged proteins present in the serum at higher concentration than cTnC. As such, the actual composition of the cTnI complex in serum will be dictated in part by its posttranslational status in the tissue (degraded and/or phosphorylated) (Fig. 4). The same applies to cTnT.

## POTENTIAL FOR DIFFERENT FRAGMENTS FOR DIFFERENT PATHOPHYSIOLOGICAL PROCESSES

### “Cytosolic” vs “Structural” Pools

#### EVIDENCE FOR EXISTENCE OF TWO CELLULAR POOLS

Based on the bimodal release kinetics of cTnI, it is assumed that there are at least two pools of troponin (26,27). They have been labeled cytosolic and structural, but the studies

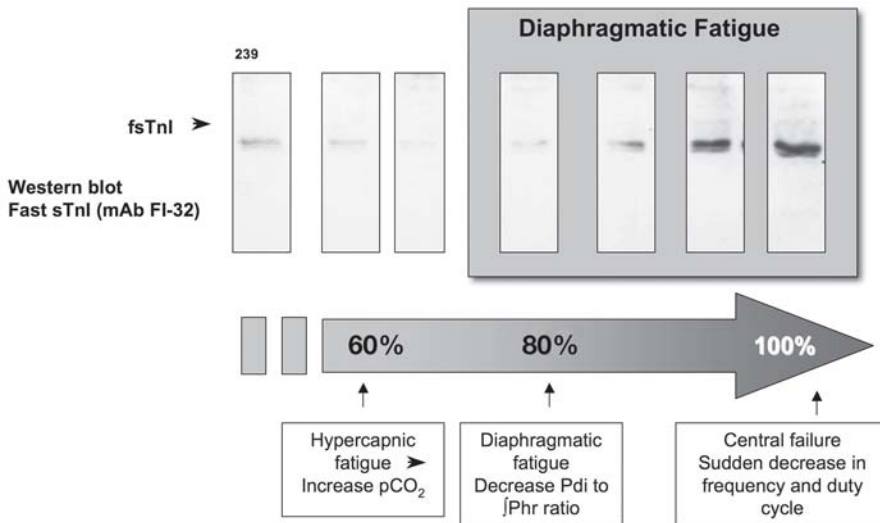
that have been conducted have usually made that distinction predicated on the ability to displace the troponin based on the buffer necessary rather than immunohistochemistry. Displacement with gentle buffers has been suggested to be associated with a “cytosolic pool” and those associated with harsher biochemical procedures with the so-called structural pool. Although conceptually difficult to envision either cTnI or cTnT (owing to their poor solubility and “stickiness”) floating freely around in the cytosol, it is possible that low levels of troponin are present in the cytosol or loosely bound to the myofilament during their incorporation (or removal) from the thin filament. Little is known about the process involved in renewal and regeneration of the thin filament, which is fundamental to understand the origin of these two physically different pools.

Analyses performed during the development of the troponin assays suggest that for cTnI, roughly 3.7% of the total troponin found in the heart is in this cytosolic or perhaps better termed early releasable pool (26), and roughly 5% for cTnT (27). Although a relatively modest percentage of the total concentrations of these proteins, it is in fact a very large amount. In comparative terms, the early releasable pool of cTnI and cTnT is very similar to the amount of CK-MB found in myocytes. It is this pool that is thought to cause the initial increases observed in patients with AMI. Subsequent release and the subsequent elevations of the cardiac troponins, which can persist for 10–14 d or even longer, are thought to be owing to the degradation of the structurally bound pool as the area of injury is remodeled. Initially, the area becomes infiltrated by inflammatory cells that utilize lysosomal enzymes to degrade the injured material, both cells and matrix and then monocytes and fibroblasts begin to repair the area with the generation of a collagen matrix, that eventually leads to fibrosis (28). Exciting data have suggested that in some circumstances new cardiomyocytes may be interdigitated with this process (29). These two pools are thought to be important in the kinetics of troponin release because of the reasonably prompt increase in the cardiac troponin in the clinical setting and the long persistence in the circulation after an acute insult. It is known from studies in which purified cardiac troponin has been injected in animals that the half-life of single chains and/or complexes in plasma is relatively short, in the range of 2–4 h (30). Thus, persistent elevations more likely reflect the continuing degradation, rather than delayed clearance. Even in patients with renal dysfunction, clearance curves do not appear to be altered (31).

#### **EVIDENCE FOR RELEASE LIMITED TO CYTOSOLIC POOL**

Cytosolic pools may be of some importance from the point of view of both pathophysiology and distinguishing reversible from irreversible myocyte injury. It is thought that perhaps the cytosolic pool could be released with injurious stimuli that are not apt to cause irreversible cellular injury. The ability to show such release experimentally and confirm that the cells are injured but have not succumbed is problematic. A good experimental example comes from monitoring skeletal troponin I release from the respiratory muscles of rats breathing against an inspiratory resistive load for which careful detection of skeletal troponin I (slow and fast skeletal troponin I monitored independently) was related to the time course of changes in arterial blood gases, respiratory drive (phrenic activity), and pressure generation (Fig. 5) (32). Modified forms of fast skeletal troponin I were detected in serum midway through loading coinciding with muscle fatigue and long before hypercapnic ventilatory failure (when it is assumed that cellular necrosis occurs) (32).

For the heart, there are several clinical situations in which transient elevations in cardiac troponin are observed with very rapid clearance that would suggest that irreversible



**Fig. 5.** Release of fast skeletal troponin I (FsTnI) during inspiratory resistive loading. A Western blot of serum obtained from a rat undergoing inspiratory resistive loading shows increased detection of specifically FsTnI during muscle fatigue prior to organ failure. The various Western blots represent different time points in the events leading up to inspiratory resistive loading-induced pump failure with cellular necrosis most likely occurring. (For more details *see* ref. 32.)

injury is not present. The two most commonly cited are exercise (33,34) and pulmonary embolism (PE) (35,36). It is now clear that at the extremes of exercise, termed *vital exhaustion*, when animals are pushed to extreme physical activity, troponin degradation in myocardium and release into plasma occurs (37). In addition, relatively minor transient increases in troponin levels have been observed in humans after extreme exercise (33,34). What is particularly interesting is that the elevations are not persistent but quite transient, usually observed during the first day, and are usually very minor in magnitude. The question then has been raised, could such elevations represent transient release from the cytosolic pool without implying that exercise causes irreversible myocyte injury? Such speculation would fit with other studies that have failed to show an adverse effect from the minor elevations and a bias, from many studies that exercise may even be good for cardiac structure and function. Perhaps a better example of this phenomenon is PE (35,36). PE causes an acute increase in pulmonary resistance and pulmonary pressures, which increases the wall stress in the right ventricle. If the right ventricle is hypertrophied, it can tolerate higher pulmonary resistances and generate higher pressures than if the ventricle has not previously been conditioned in some way that results in a hypertrophic response. However, in experimental models, it is difficult to cause irreversible damage to the right ventricle (38,39). This is, in large part, because it is generally thin and, therefore, can receive nutrients from the cavity, and it has a gradient for collateral blood flow because of the lower pressure in the right ventricle compared with the left ventricle and the right ventricle manifests a dual blood supply as well. Thus, the increases in troponin seen in acute PE that evolve rapidly and are gone by 40 h have been used to suggest that such transient elevations may be a reflection of reversible injury. If so, this suggests that a cytosolic pool that releases the troponin and perhaps the structural pool, which would only likely be degraded in response

to cell death, may be preserved. Such speculation would fit with the experimental and clinical data that suggest it is difficult to injure irreversibly the right ventricle (38,39).

### *Potential Diagnostic Application*

To the extent that the hypothesis that the release of troponin in the clinical and experimental examples just discussed is limited to the cytosolic pool is correct, this paradigm would imply that if one could characterize the fragments within the cytosolic pool and distinguish them from the fragments in the structural pool, one might begin to at least answer the question of reversible vs irreversible damage. For example, it does appear that the troponin within the cell is in the form of free chains and it is known that larger fragments, complexes, are released with severe ischemic insults (23–25).

It is conceivable but unproven that the nature of those fragments could depend on the nature of the injurious stimulus. As mentioned previously, modification of troponin fragments is believed to occur in tissue. Thus, the heterogeneity of fragments demonstrated may be related in part to residence time in the myocardium (40,41). It is likely that the duration in the tissue is a function, at least in part, of blood flow, with larger cellular proteins being washed out more slowly than membrane-bound constituents (40,41).

## POTENTIAL OF FRAGMENT ANALYSIS

### *Clinical and Experimental Examples*

The opportunity to use fragment analysis to determine reversible vs irreversible injury is but a small part of the potential of this exciting approach. If the conversion and release of these forms is not rapidly followed by degradation in the plasma by proteases that further process the fragments, it is conceivable that one could observe different fragments with different diseases (Fig. 4). There are several bases from which to anticipate that these differential patterns may exist. First, as articulated in detail in the preceding section, there is the notion of a “cytosolic pool” containing mostly free proteins (polypeptide chains) in contrast to the structural pool. Second, there is the additional clinical example of renal failure. It is well known that cTnT is more frequently elevated than cTnI (42) even when assays thought to have similar clinical sensitivities and other circumstances are used. The reasons for this discrepancy are unclear. However, investigators have raised the possibility that the fragments that occur in renal failure may be different (43). In keeping with the fact that the antibody recognition sites for troponin T are quite close together, fragments of cTnT have been documented to include very small ones (Fig. 4). By contrast, the antibody recognition sites for cTnI, though not terribly distant, are said to be much farther apart. It has been proposed that processing in patients with renal failure could eliminate some of the epitopes for the detection of cTnI and could even open additional epitopes for the detection of cTnT. Fragment analysis may permit exploration of this important issue that carries significant clinical implications. Third, experimental models suggest several additional settings in which specific modifications of troponin may occur. For example, Feng et al. (44) showed that acute increases in preload lead to proteolysis of cTnI and release most likely via a calpeptin-mediated mechanism. This mechanism might also be relevant both to a dialysis population in whom intravascular volumes go up and down frequently, and to a heart failure population in whom rapid changes in preload could lead to the release of troponin. Feng et al.’s (44) data suggest that the cells eventually die as the result of apoptosis. This finding raises the possibility that troponin fragments may be released in other situations in which apoptosis occurs (45).

N-terminal degradation of cTnI can occur both with ischemic-induced damage (46) and with simulated microgravity (47) and is thought to occur during normal myocyte turnover (48) (Fig. 2). However, the actual N-terminal degradation products appear to differ based on the physiological (residues 1–26, 1–27, or 1–30 being proteolyzed [47]) and pathological conditions (1–63 and 1–73 being proteolyzed) (46) (Fig. 4). Furthermore, in a low flow ischemic model in dogs, it was cTnT, not cTnI, that underwent degradation (49), indicating that monitoring the fragmentation (or absence of degradation) of both molecules could lead to additional clinical insight.

Clearly, understanding differences in the type of fragments that are derived may lead to improved diagnosis of the underlying pathological process, particularly in settings in which it is challenging to discriminate conditions on clinical grounds. For example, because the most common cause of heart failure is ischemic heart disease, it is difficult to know whether or not troponin elevations in patients presenting with heart failure represent underlying coronary heart disease, supply/demand ischemia, or the effects of heart failure independent of either of those disease entities. Because increased concentrations of troponin are present in patients with idiopathic cardiomyopathy, it is clear that coronary artery disease is not necessary for the release of troponin to occur (50). It is conceivable that the processing of fragments is different owing to variation in the injurious stimulus, and if so, identification of the proper fragment might lead to a better diagnosis. This approach will be highly sensitive to the location in which fragment processing occurs. If all processing occurs within myocardium and no processing occurs in plasma, the detection of specific fragment patterns will be far more simple. On the other hand, if serum proteases alter the fragments after release from myocytes, it may become much more complicated to determine which patterns exist owing to the underlying pathophysiology vs subsequent processing in the blood.

### *Improvement in Assays for Troponin*

Finally, it may well be that the sensitivity of the present methods for the measurement of troponin may be improved by reliably detecting complexes when they are present, and being able to denature them so that more epitopes are available for detection with conventional antibodies. The antibodies used in commercial assays vary tremendously. Some are capable of detecting single chains extremely well, whereas others tend to detect complexes (51). These issues of antibody specificity have posed problems, with two assays as notable examples. An early cTnT assay had a lack of a totally specific capture antibody of troponin T (52), which led to false positive results. Another assay had an antibody to the carboxy-terminal end where cleavage occurred in plasma, rendering the protein undetectable (53). Thus, one way to begin to move toward increased sensitivity, harmonization of testing, and obviation of interferences may be to denature the complexes.

## POTENTIAL BIOLOGICAL EFFECTS

In addition to the potential to understand and diagnose different disease entities predicated on fragment analysis, there is the possibility that different fragments may have differential biological activity. The best fragment studied is the 1–192 (1–193 in rat) protein derived from cleavage of the 17 terminal amino acids on the carboxy-terminal end of human cTnI (41). This protein has been characterized in myocardium in patients undergoing bypass surgery and when overexpressed in transgenic animals is associated with a cardiomyopathy with reduced force and unaltered calcium handling, properties similar to those seen with stunned myocardium (54). Further analysis revealed that there may be

an imbalance or uncoupling between force and energy requirement with the C-terminal truncated cTnI (55), which could further exacerbate the cardiac dysfunction. Thus, not only is there the potential for diagnostic information, but if indeed fragments such as cTnI 1–192 have differential biological activity, it may well be that their detection could lead to anticipation and/or prognostication of clinical effects. For example, if cTnI amino acid residues 1–192 were a marker of stunning and high levels could be detected, one could then predict improvement in cardiac function predicated on this fragment. Moreover, inhibition of the biological effects of this and other specific fragments might translate into potent therapeutic approaches.

## CONCLUSION

If successful, the ability to distinguish disease entities based on fragment analysis has the potential to revolutionize the field by allowing more specific diagnoses, leading to more complete understanding of cardiac injury that occurs in patients without ACS, and markedly improving the sensitivity of assays for troponin.

## ACKNOWLEDGMENTS

The authors would like to thank the following for their contributions, either intellectual or schematic or in the form of figures: Ralf Labugger, John Solaro, Anne Murphy, Jason McDonough, and Jeremy Simpson.

## REFERENCES

1. Dhoot GK, Gell PG, Perry SV. The localization of the different forms of troponin I in skeletal and cardiac muscle cells. *Exp Cell Res* 1978;117:357–370.
2. Cummins P, Perry SV. Troponin I from human skeletal and cardiac muscles. *Biochem J* 1978;171:251–259.
3. Katus HA, Remppis A, Looser S, Hallermeier K, Scheffold T, Kubler W. Enzyme linked immuno assay of cardiac troponin T for the detection of acute myocardial infarction in patients. *J Mol Cell Cardiol* 1989;21:1349–1353.
4. Bodor GS, Porter S, Landt Y, Ladenson JH. Development of monoclonal antibodies for an assay of cardiac troponin-I and preliminary results in suspected cases of myocardial infarction. *Clin Chem* 1992;38:2203–2214.
5. Adams JE 3rd, Abendschein DR, Jaffe AS. Biochemical markers of myocardial injury: is MB creatine kinase the choice for the 1990s? *Circulation* 1993;88:750–763.
6. Bodor GS, Survant L, Voss EM, Smith S, Porterfield D, Apple FS. Cardiac troponin T composition in normal and regenerating human skeletal muscle. *Clin Chem* 1997;43:476–484.
7. Ricchiuti V, Voss EM, Ney A, Odland M, Anderson PA, Apple FS. Cardiac troponin T isoforms expressed in renal diseased skeletal muscle will not cause false-positive results by the second generation cardiac troponin T assay by Boehringer Mannheim. *Clin Chem* 1998;44:1919–1924.
8. Haller C, Zehelein J, Remppis A, Muller-Bardorff M, Katus HA. Cardiac troponin T in patients with end-stage renal disease: absence of expression in truncal skeletal muscle. *Clin Chem* 1998;44:930–938.
9. Alpert JS, Thygesen K, Antman E, Bassand JP. Myocardial infarction redefined—a consensus document of The Joint European Society of Cardiology/American College of Cardiology Committee for the redefinition of myocardial infarction. *J Am Coll Cardiol* 2000;36:959–969.
10. Myocardial infarction redefined—a consensus document of The Joint European Society of Cardiology/American College of Cardiology Committee for the redefinition of myocardial infarction. *Eur Heart J* 2000;21:1502–1513.
11. Ottani F, Galvani M, Nicolini FA, et al. Elevated cardiac troponin levels predict the risk of adverse outcome in patients with acute coronary syndromes. *Am Heart J* 2000;140:917–927.
12. Jaffe AS, Davidenko J, Clements I. Diagnosis of acute coronary syndromes including acute myocardial infarction. In: Crawford MH, DiMarco JP, Paulus WJ, eds. *Cardiology*. Mosby, Edinburgh, UK, 2004, pp. 311–328.

13. Jaffe AS. Elevations in cardiac troponin measurements: false false-positives. *Cardiovasc Toxicol* 2001; 1(2):87–92.
14. Guest TM, Ramanathan AV, Schechtman KB, Ladenson JH, Jaffe AS. Myocardial injury in critically ill medical patients: a frequently unrecognized complication. *JAMA* 1995;273:1945–1949.
15. Wright RS, Williams BA, Lewis L, et al. Elevations of cardiac troponin I are associated with increased short-term mortality in non-cardiac critically ill emergency department patients. *Am J Cardiol* 2002;90: 634–636.
16. Gordon AM, Homsher E, Regnier M. Regulation of contraction in striated muscle. *Physiol Rev* 2000; 80(2):853–924.
17. Metzger JM, Westfall MV. Covalent and noncovalent modification of thin filament action: the essential role of troponin in cardiac muscle regulation. *Circ Res* 2004;94(2):146–158.
18. Solaro RJ. The special structure and function of troponin I in regulation of cardiac contraction and relaxation. *Adv Exp Med Biol* 2003;538:389–401.
19. Sumandea MP, Burkart EM, Kobayashi T, De Tombe PP, Solaro RJ. Molecular and integrated biology of thin filament protein phosphorylation in heart muscle. *Ann NY Acad Sci* 2004;1015:39–52.
20. McDonough JL, Van Eyk JE. Developing the next generation of cardiac markers: disease-induced modifications of troponin I. *Prog Cardiovasc Dis* 2004;47:207–216.
21. Solaro RJ, Moir AJ, Perry SV. Phosphorylation of troponin I and the inotropic effect of adrenaline in the perfused rabbit heart. *Nature* 1976;262(5569):615–617.
22. Murphy A, Van Eyk JE. The role of troponin abnormalities as a definitive cause for stunned myocardium. *Coron Artery Dis* 2001;12:343–347.
23. Katrukha AG, Bereznikova AV, Esakova TV, et al. Troponin I is released in bloodstream of patients with acute myocardial infarction not in free form but as complex. *Clin Chem* 1997;43:1379–1385.
24. Wu AH, Feng YJ, Moore R, et al. Characterization of cardiac troponin subunit release into serum after acute myocardial infarction and comparison of assays for troponin T and I. American Association for Clinical Chemistry Subcommittee on cTnI Standardization. *Clin Chem* 1998;44:1198–1208.
25. Labugger R, Simpson JA, Quick M, et al. Strategy for analysis of cardiac troponins in biological samples spectrometry. *Clin Chem* 2003;49:873–879.
26. Adams JE 3rd, Schechtman KB, Landt Y, Ladenson JH, Jaffe AS. Comparable detection of acute myocardial infarction by creatine kinase MB isoenzyme and cardiac troponin I. *Clin Chem* 1994;40:1291–1295.
27. Katus HA, Remppis A, Scheffold T, Diederich KW, Kuebler W. Intracellular compartmentation of cardiac troponin T and its release kinetics in patients with reperfused and nonreperfused myocardial infarction. *Am J Cardiol* 1991;67:1360–1367.
28. Jugdutt BI. Ventricular remodeling after infarction and the extracellular collagen matrix: when is enough enough? *Circulation* 2003;108:1395–1403.
29. Lee MS, Makkar RR. Stem-cell transplantation in myocardial infarction: a status report. *Ann Intern Med* 2004;140:729–737.
30. Jaffe AS, Landt Y, Parvin CA, Abendschein DR, Geltman EM, Ladenson JH. Comparative sensitivity of cardiac troponin I and lactate dehydrogenase isoenzymes for diagnosing acute myocardial infarction. *Clin Chem* 1996;42:1770–1776.
31. Ellis K, Dreisbach AW, Lertora JL. Plasma elimination of cardiac troponin I in end-stage renal disease. *South Med J* 2001;94:993–996.
32. Simpson JA, Van Eyk JE, Isoce S. Respiratory muscle injury, fatigue and serum skeletal troponin I in rat. *J Physiol* 2004;554:891–903.
33. Neumayr G, Gaenzer H, Pfister R, et al. Plasma levels of cardiac troponin I after prolonged strenuous endurance exercise. *Am J Cardiol* 2001;87:369–371, A10.
34. Rifai N, Douglas PS, O'Toole M, Rimm E, Ginsburg GS. Cardiac troponin T and I, echocardiographic [correction of electrocardiographic] wall motion analyses, and ejection fractions in athletes participating in the Hawaii Ironman Triathlon. *Am J Cardiol* 1999;83:1085–1089.
35. Muller-Bardorf M, Weidtmann B, Giannitsis E, Kurowski V, Katus HA. Release kinetics of cardiac troponin T in survivors of confirmed severe pulmonary embolism. *Clin Chem* 2002;48:673–675.
36. La Vecchia L, Ottani F, Favero L, et al. Increased cardiac troponin I on admission predicts in-hospital mortality in acute pulmonary embolism. *Heart (British Cardiac Society)* 2004;90:633–637.
37. Chen Y, Serfass RC, Mackey-Bojack SM, Kelly KL, Titus JL, Apple FS. Cardiac troponin T alterations in myocardium and serum of rats after stressful, prolonged intense exercise [see comment]. *J Appl Physiol* 2000;88:1749–1755.



38. Laster SB, Shelton TJ, Barzilai B, Goldstein JA. Determinants of the recovery of right ventricular performance following experimental chronic right coronary artery occlusion. *Circulation* 1993;88:696–708.
39. Laster SB, Ohnishi Y, Saffitz JE, Goldstein JA. Effects of reperfusion on ischemic right ventricular dysfunction: disparate mechanisms of benefit related to duration of ischemia. *Circulation* 1994;90:1398–1409.
40. Labugger R, Organ L, Collier C, Atar D, Van Eyk JE. Extensive troponin I and T modification detected in serum from patients with acute myocardial infarction. *Circulation* 2000;102:1221–1226.
41. McDonough JL, Labugger R, Pickett W, et al. Cardiac troponin I is modified in the myocardium of bypass patients. *Circulation* 2001;103:58–64.
42. Apple FS, Murakami MM, Pearce LA, Herzog CA. Predictive value of cardiac troponin I and T for subsequent death in end-stage renal disease. *Circulation* 2002;106:2941–2945.
43. Diris JHC, Hackeng CM, Kooman JP, Pinto YM, Hermens WT, van Dieijen-Visser MP. Impaired renal clearance explains elevated troponin T fragments in hemodialysis patients. *Circulation* 2004;109:23–25.
44. Feng J, Schaus BJ, Fallavollita JA, Lee TC, Canty JM Jr. Preload induces troponin I degradation independently of myocardial ischemia. *Circulation* 2001;103:2035–2037.
45. Anversa P, Cheng W, Liu Y, Leri A, Redaelli G, Kajstura J. Apoptosis and myocardial infarction. *Basic Res Cardiol* 1998;93(Suppl 3):8–12.
46. McDonough JL, Arrell DK, Van Eyk JE. Troponin I degradation and covalent complex formation accompanies myocardial ischemia/reperfusion injury. *Circ Res* 1999;84:9–20.
47. Yu ZB, Zhang LF, Jin JP. A proteolytic NH<sub>2</sub>-terminal truncation of cardiac troponin I that is up-regulated in simulated microgravity. *J Biol Chem* 2001;276:15,753–15,760.
48. Marston SB, Redwood CS. Modulation of thin filament activation by breakdown or isoform switching of thin filament proteins: physiological and pathological implications. *Circ Res* 2003;93:1170–1178.
49. Colantonio DA, Van Eyk JE, Przyklenk K. Stunned peri-infarct canine myocardium is characterized by degradation of troponin T, not troponin I. *Cardiovasc Res* 2004;63:217–225.
50. Sato Y, Yamada T, Taniguchi R, et al. Persistently increased serum concentrations of cardiac troponin T in patients with idiopathic dilated *cardiomyopathy* are predictive of adverse outcomes. *Circulation* 2001;103:369–374.
51. Datta P, Foster K, Dasgupta A. Comparison of immunoreactivity of five human cardiac troponin I assays toward free and complexed forms of the antigen: implications for assay discordance. *Clin Chem* 1999;45:2266–2269.
52. Li D, Keffer J, Corry K, Vaquez M, Jialal I. Nonspecific elevation of troponin T levels in patients with chronic renal failure. *Clin Biochem* 1995;28:474–477.
53. Shi Q, Ling M, Zhang X, et al. Degradation of cardiac troponin I in serum complicates comparisons of cardiac troponin I assays. *Clin Chem* 1999;45:1018–1025.
54. Murphy AM, Kogler H, Georgakopoulos D, et al. Transgenic mouse model of stunned myocardium. *Science* 2000;287:488–491.
55. Foster DB, Noguchi T, VanBuren P, Murphy A, Van Eyk JE. C-terminal truncation of cardiac troponin I uncouples the force-ATPase relation: implication for the pathophysiology of myocardial stunning. *Circ Res* 2003;93:917–924.

# II

---

## BIOMARKERS OF ISCHEMIA

---



# 12

---

## Developing a Marker of Ischemia

### *Clinical and Research Challenges*

---

*Robert L. Jesse, MD, PhD*

#### CONTENTS

INTRODUCTION

FRAMING THE CLINICAL NEED FOR BIOMARKERS OF ISCHEMIA

DETECTION OF MYOCARDIAL ISCHEMIA

THE QUEST FOR A BIOCHEMICAL MARKER OF MYOCARDIAL ISCHEMIA

CLINICAL CHALLENGES TO THE DEVELOPMENT OF ISCHEMIA MARKERS

CONCLUSION

REFERENCES

---

#### SUMMARY

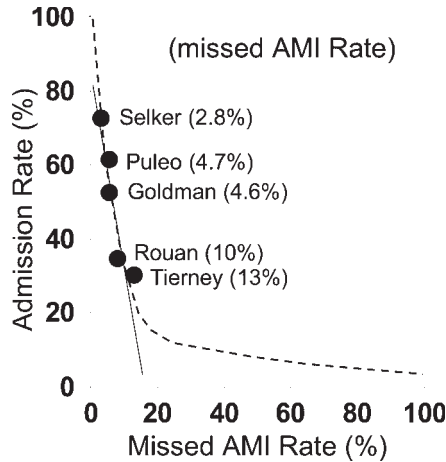
Assessment of the patient with suspected acute coronary syndrome (ACS) has remained challenging despite the growing armamentarium of both diagnostic and prognostic tests. Inadvertent discharge of patients thought to be at low risk of ischemia but later found to have an ACS remains unacceptably high. Present tools (history, clinical examination, electrocardiogram, and biomarkers of necrosis) are not optimally sensitive for the identification of patients with unstable angina. Technetium-based myocardial perfusion imaging is sensitive and specific and provides proof of principle that myocardial ischemia is both detectable and actionable. However, this technology is expensive and requires significant technical expertise. Biochemical tests have historically proven to be fast, accurate, simple to perform, relatively easy to interpret, and inexpensive. All of these characteristics provide a strong argument toward development of biochemical markers of myocardial ischemia. Nevertheless, there are many challenges to this effort. The physiology is complex, and it is complicated by the issues of chronicity, timing, and severity. The absence of a “gold standard” for diagnosis of unstable angina makes comparative analyses difficult to interpret. However, if successful, the potential payback is tremendous in terms of improved clinical management and outcomes.

**Key Words:** Unstable angina; ischemia; biomarkers; diagnosis.

#### INTRODUCTION

Assessing patients with suspected acute coronary syndrome (ACS) remains problematic even though there is a growing armamentarium of diagnostic and prognostic tests as well as continued improvement in the sensitivity and specificity of existing methods. The

From: *Contemporary Cardiology:  
Cardiovascular Biomarkers: Pathophysiology and Disease Management*  
Edited by: David A. Morrow © Humana Press Inc., Totowa, NJ



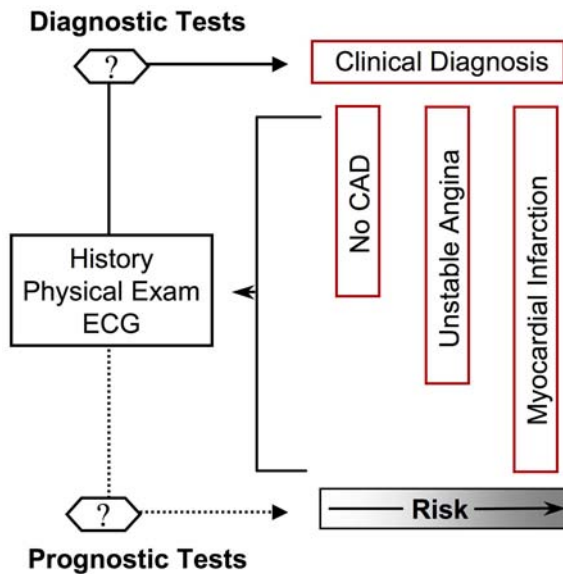
**Fig. 1.** Relationship between admission rate and missed acute myocardial infarction (AMI) rate. Several historical studies have compared the rate of admission for patients presenting with chest pain with that of inadvertent discharge of patients having AMI. A plot of this relationship developed by Graff et al. (3) was originally presented as linear (solid line), though it is more likely that this represents a curvilinear relationship (dashed line) that would reflect a 100% miss if all patients were discharged, and a 100% capture if all patients were admitted. Note the small decrement in missed AMI rate once the admission rate exceeds 50% relative to those when below 50%. Also note that these studies predate the widespread implementation of chest pain emergency rooms, which are designed in part to lower the missed AMI rate. (Data are from refs. 15,52–55.)

percentage of inadvertent discharges of patients thought to be at low risk of ischemia but later found to have an ACS remains unacceptably high, at 4 to 5%, of whom about half have an acute myocardial infarction (AMI) and the remainder unstable angina (1). This limitation adversely impacts clinical outcomes, as well as the cost of health care (2) and underlies the need for exploration of new strategies aimed at rapidly identifying those patients who present with ACS but lack traditional diagnostic findings, including definitive electrocardiogram (ECG) findings, and/or biochemical evidence of necrosis. Biomarkers hold promise to be valuable in this regard. This chapter presents the rationale behind the quest for biochemical markers of myocardial ischemia, including the physiological basis, the clinical imperatives, and the challenges inherent in both.

## FRAMING THE CLINICAL NEED FOR BIOMARKERS OF ISCHEMIA

### *Risk Stratification Among Patients With Nontraumatic Chest Pain*

Given the current level of diagnostic uncertainty, risk stratification of every patient with possible ACS has become the foundation of virtually all chest pain evaluation strategies. An effective strategy to reduce the probability of inadvertently discharging a patient with ACS is to admit every patient who presents with chest pain or related symptoms. The correlation between increased admissions and reduced missed AMI rates is well described (Fig. 1) (3). Unfortunately, admitting large numbers of patients unnecessarily is not economically viable and is increasingly difficult to justify in the face of current constraints on hospital bed capacity. Utilization of standardized risk-based strategies that avoid admission for lower-risk patients is now well established as both clinically sound and cost-effective.



**Fig. 2.** Evaluation of patient presenting with chest pain. The initial evaluation of the patient presenting with chest pain, primary risk stratification, is based on differentiating ACS from non-ACS and is done via the history, physical examination, and ECG. The sensitivity for this is high but not perfect. Although a limited number of high-risk AMI patients can be identified by the ECG, it is impossible on this basis alone to correctly identify all ACS patients, or to differentiate unstable angina from MI. Thus, a secondary risk stratification process including biomarkers of myocardial necrosis and imaging techniques is performed to identify the remainder of the higher-risk patients. Ultimately, the results of such testing may either provide a definitive diagnosis or contribute to the ongoing risk assessment process. CAD, coronary artery disease.

The current convention that all chest pain patients must be rapidly evaluated for the probability of an ACS through an initial assessment based on the ECG, history, and physical examination is referred to as “primary risk stratification” (4). ST-segment deviation, either elevation or depression, identifies higher-risk cohorts for whom specific therapies should be initiated and admission to a critical care unit is indicated. Guidelines for the evaluation and treatment of these patients have been recently published (5–7). The remaining patients constitute a cohort for whom the probability of ACS is lower, but not absent. Among these “lower-risk” patients, often comprising up to two-thirds of all emergency department (ED) patients undergoing a chest pain evaluation, there is a small group for whom ACS is the cause of their presenting symptoms. Although this incidence of occult ACS is low, failure to identify those few higher-risk patients remains problematic (2). For this reason, a “secondary risk stratification” process must be initiated when the diagnosis is not certain (Fig. 2). This process includes a number of biochemical markers, imaging modalities, and provocative tests.

Chest pain evaluation programs, (e.g., chest pain emergency rooms, clinical diagnostic units), are now in place in many hospitals and incorporate protocols, pathways, and clinical practice guidelines to provide consistency and structure to the evaluation and management of the patient with nontraumatic chest pain. Whereas erratic variation in practice contributes to lower quality of care and to higher costs owing to inappropriate utilization of resources (8), a systematic approach can reduce costs for chest pain evaluation through improved efficiency (9,10). This observation has fueled efforts to generate consensus as

to the structural, procedural, organizational, and managerial components required for effective chest pain evaluation (11). However, no amount of organizational efficiency can replace the ability to provide the right test needed to guarantee the right diagnosis at the right place and time.

### *Pathophysiology of ACS*

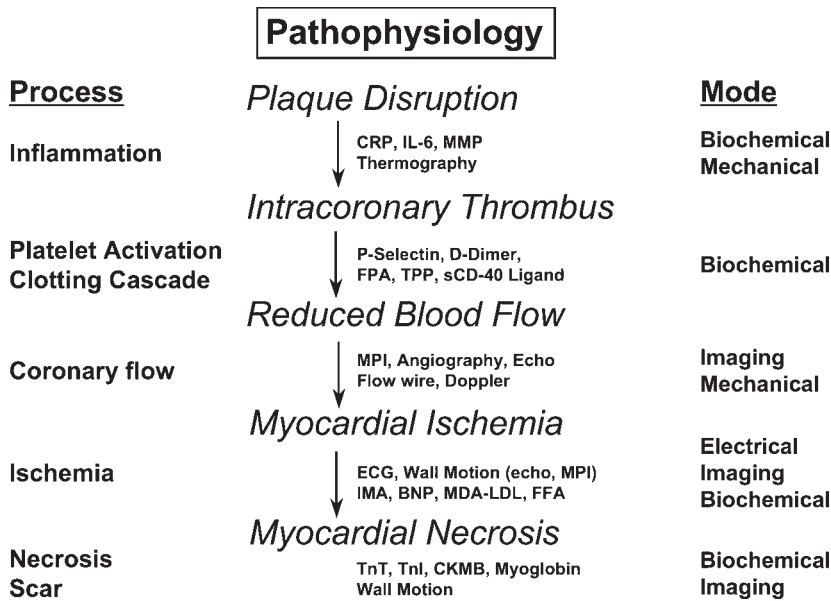
The development of biochemical markers for ACS requires an understanding of the pathophysiology of atherothrombotic coronary artery disease. This condition is chronic and progressive, marked by episodic acute manifestations, including unstable angina and AMI, which are infrequent, but potentially fatal. The precipitating event in ACS is most often disruption of a “vulnerable” atherosclerotic plaque weakened by inflammation, exposing the highly thrombogenic subendothelial components of the atheroma core (12, 13). In many cases, obstruction of the coronary artery by thrombus is minimal, resulting in little or no impairment to coronary flow. Alternatively, the thrombus can result in total occlusion of the artery with classic symptoms and ECG findings. The combination of reduced blood flow and increased oxygen demand precipitates the critical imbalance of oxygen supply and demand that leads to myocardial ischemia (i.e., unstable angina). Persistent ischemia can result in myocyte death, which may be detected using biomarkers of necrosis and forms the basis for the diagnosis of AMI (14). Necrosis is an irreversible terminal event and its presence signifies considerable risk. To prevent necrosis from occurring, one must detect ACS earlier in its course and intervene. Thus, the detection of ischemia provides the optimal opportunity for early diagnosis and intervention in patients with ACS.

### *Diagnosis of ACS*

The diagnosis of ACS is predicated on evidence of the physiological process just described. Although the initial assessment typically occurs with limited data, including only the history, physical examination, and ECG, the sensitivity of this strategy is good, approx 93–95% (15–17). However, unfortunately, the consequences of missed diagnoses are high (16,17), with increased morbidity and mortality (1,18). Failure to make a diagnosis of AMI remains the single highest payout for malpractice litigation against ED physicians (19). Moreover, only approx 20% of the malpractice claims for missed MI are against ED physicians, with almost 70% against primary care physicians. In addition to the objective of reducing the number of missed MIs, optimal care of the population with ACS requires rapid identification of those with ischemia prior to the onset of necrosis (20).

The understanding of the pathophysiology of ACS provides a myriad of opportunities for diagnostic and prognostic testing within this pathophysiological construct (Fig. 3). However, assessment at different stages or of different contributors to the genesis of ACS is likely to have different implications for prognosis and therapy. Thus, the evaluation of new tools for diagnostic and prognostic application in ACS should be distinguished along the following lines:

1. *Chronicity*: A distinction must be made between “disease-state” markers specific to atherosclerosis and “acute event” markers, such as necrosis markers used for the detection of AMI.
2. *Timing*: The window during which a test may be useful is discrete and varies widely among tests.



**Fig. 3.** Targets for detection of ACSs. When the components of ACS are considered individually, there are multiple targets for detection at all levels. The two historical standards have been the detection of ischemia via the ECG and the detection of necrosis using biomarkers; the limitations to each are discussed in the text. Plaque disruption and thrombus formation may be such frequent events that their detection may signal a period of elevated risk more so than the actual occurrence of ACS as it is known clinically. Biomarkers for these processes may provide information about risk but are unlikely to be useful for the diagnosis of an acute event if this frequency of occurrence is high. At present, there are no biochemical markers for reduced intracoronary blood flow, so ischemia is the likely target for biomarker development aimed at preventing necrosis. CRP-C, reactive protein; IL-6, interleukin-6; MMP, matrix metalloproteinase; FPA, fibrinopeptide A; TPP, thrombus precursor protein; BNP, B-type natriuretic peptide; TnI, troponin I; TnT, troponin T.

3. *Severity:* Any test may be influenced by the magnitude of the perturbation being studied.
4. *Context:* The value of certain tests may be limited to or influenced by the specific situation in which it is being used. Interpretation of any test result must consider the clinical situation in which the test is being performed, and the specific information provided.

## DETECTION OF MYOCARDIAL ISCHEMIA

### *Electrocardiography*

The ECG has long been the standard for the detection of ischemia. This capitalizes on the fact that ischemic myocardium repolarizes differently than normal myocardium, seen as changes in the ST-complex. Ischemic myocardium also does not contract normally because energy production and utilization are altered. Thus, the effects of ischemia can be observed by examining myocardial function through a number of imaging modalities. Finally, ischemia interferes with a myriad of biochemical processes and metabolic pathways, providing additional opportunities for detection.

ACS is a dynamic syndrome, and ischemic ECG changes are temporal in nature. This variability results in significant loss of sensitivity because any changes that do occur during ischemia may be transient (21). The role for serial ECGs in maximizing sensitivity



for ischemia is intuitive but does not entirely overcome this limitation. For instance, there are areas of the heart that are difficult to “see” with the ECG, particularly in the left circumflex distribution. Small areas of ischemia may be missed altogether. Enhancing the ECG with additional inputs, including continuous ST-segment monitoring or enhanced lead configurations (22–24), decreases but does not completely obviate these limitations. Again, it must be remembered that the ECG sensitivity is limited because ischemic changes are evanescent. These temporal aspects remain a significant hindrance to the usefulness of the ECG in detecting ACS. The addition of immediate exercise treadmill testing has been used to improve sensitivity. Amsterdam et al. (25) reported on their experience with 1000 low-risk patients with nontraumatic chest pain who underwent symptom-limited exercise testing in the ED. Thirteen percent had a positive test, 23% were nondiagnostic, and the remaining 64% were discharged home (25).

### ***Myocardial Perfusion Imaging***

When the ECG is nondiagnostic, myocardial perfusion imaging (MPI) can assist in risk stratification. The effectiveness of MPI is reflected in recent American College of Cardiology/American Heart Association/American Society for Nuclear Cardiology guidelines that assign this a class IA recommendation for the assessment of risk in patients with possible ACS when the ECG is nondiagnostic (26). The guideline stipulates that it is most appropriate for patients who have “possible” ACS following an initial triage based on the symptoms, ECG, and history. In this situation, rest MPI appears to be able to segregate patients at high risk who should be admitted from those at low risk who can be discharged home. Virtually every study incorporating technetium-based MPI in chest pain evaluation protocols has demonstrated a sensitivity of 90–100%, and a negative predictive value >99% for excluding ACS and the occurrence of short-term cardiac events (27–31). This high negative predictive value permits lower-risk patients with a negative test to be discharged safely from the ED within a couple of hours.

MPI is effective for detecting ACS, both with and without MI, with a sensitivity for the diagnosis of AMI similar to that for *serial* measurement of cardiac troponin. Notably, the sensitivity of the *initial* determination of troponin is limited to about 30%, whereas MPI is able to identify most patients with AMI rapidly. In addition, the sensitivity for predicting cardiac end points other than MI is significantly higher for MPI than for any other modality (27). “Perfusion imaging” is, to some extent, a misnomer for the technetium-based imaging agents because they fundamentally detect ischemia. Even in the presence of adequate perfusion, residual ischemia may appear as an abnormality. These agents can also be gated to the ECG to construct functional displays where regional wall motion can be assessed. The matched defects of perfusion and wall motion is a strong indicator that ischemia has occurred.

### ***Role for a Biomarker of Ischemia***

The surface 12-lead ECG, along with perfusion and functional imaging, provides proof of principle that ischemia can be detected early in the course of ACS. Furthermore, the absence of ischemia using this approach indicates low risk and allows safe discharge, while the rapid detection of ischemia provides an opportunity for early intervention that can improve outcomes, especially if necrosis has not yet occurred (32). Nevertheless, dependence on the ECG and symptoms alone is insufficiently sensitive, and strategies that include perfusion and functional imaging require a substantial investment in technology and expertise that has hindered their widespread application.

This major limitation could be overcome if ischemia could be reliably detected biochemically. A simple assay with high sensitivity and specificity for cardiac ischemia and a kinetic profile useful for an acute event marker would greatly simplify and improve the safety of the chest pain evaluation process. Biochemical tests tend to be relatively inexpensive and practical to perform, thus allowing widespread application. They can generally be performed with rapid turnaround, providing support for clinical decision making. Understanding the pathophysiology of ACS, the biochemical changes that occur, and the attendant clinical imperatives has fostered a concerted effort aimed at identifying biochemical markers of ischemia that can be widely applied toward the evaluation of patients with possible ACS.

## THE QUEST FOR A BIOCHEMICAL MARKER OF MYOCARDIAL ISCHEMIA

Finding a sensitive and specific biochemical marker to demonstrate ischemia has been elusive. Specific candidate biomarkers are discussed in detail in Chapter 13. Before considering the evaluation of these markers, a broader overview of the approaches that have been taken in the pursuit of markers of ischemia is useful.

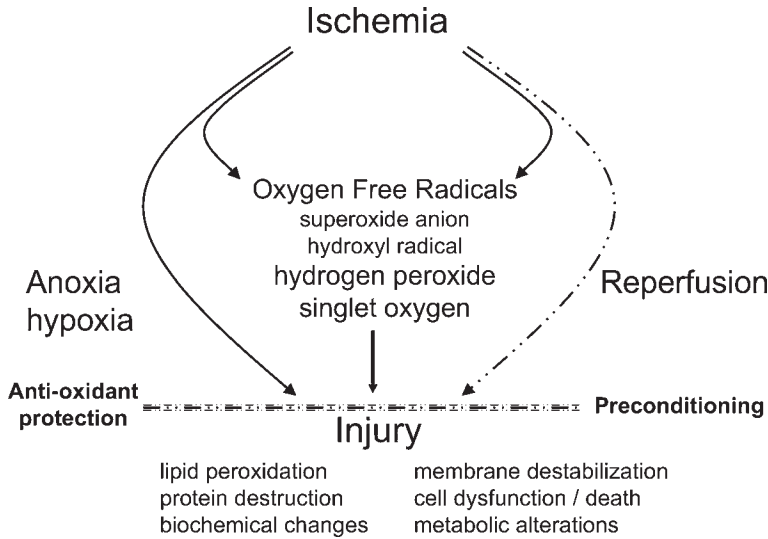
### *Approaches Related to Reactive Oxygen Species*

#### REACTIVE OXYGEN SPECIES IN ATHEROTHROMBOSIS

Ischemia can result in tissue damage through the formation of a number of injurious compounds. A significant body of research over the past 15–20 yr has focused on the role of reactive oxygen species (ROS), including oxygen free radicals, singlet oxygen, and peroxides. The tissue damage induced by such compounds is well described and appears to be an ubiquitous biological phenomenon (Fig. 4). The alterations that occur to proteins, lipids, nucleic acids, membranes, and so forth are relatively independent of the tissue involved. However, the propensity to generate any specific ROS may differ among tissues and even between species for the same tissue. Furthermore, natural protective measures, such as catalase and superoxide dismutase, also vary in their distribution among tissues and show significant interspecies variations. Both the inherent propensity to generate a specific profile of ROS under given pathophysiological conditions and the intrinsic protective pathways will ultimately determine the response to ischemia. This is an important point because it raises challenges to studying animal models in which to develop new markers for detecting human disease.

The role of ROS in atherogenesis has been well documented, in particular through the oxidation of low-density lipoprotein (LDL) (33). Holvoet et al. (34) demonstrated that there was an increase in a specific oxidized species of LDL (malondialdehyde [MDA]-modified LDL) in patients with ACS. Of note, both AMI and unstable angina showed similar elevations in MDA-modified LDL, and subsequent analyses have suggested that this may not be an acute marker of ischemia but, rather, reflects an underlying state linked to the development of coronary atherosclerosis. This difference raises an important consideration for biomarker development, because markers that are specific to the disease state of atherosclerosis may not be useful for the detection of acute events such as ischemia. Following the temporal changes in biomarkers during evaluation (i.e., a rise and fall in relation to the ischemic event) is likely to be useful in distinguishing those that may be viable as event markers.

There are novel biochemical pathways identified that become activated after exposure of the myocardium to brief periods of ischemia, allowing cells to better tolerate subse-



**Fig. 4.** Mechanism of oxidative tissue damage by ROS. Ischemia and the reperfusion that follows can result in the formation of free radicals and other ROS, including peroxides. All are capable of damaging tissues, and many biological safeguards at the cellular level have evolved to protect against oxidant damage. Ischemia/reperfusion can also be protective, in that short periods of ischemia followed by reperfusion can invoke a “preconditioning process” (*see text*) that affords cells protection against subsequent ischemic damage.

quent periods of ischemia. This so-called ischemic preconditioning appears to be related, at least in part, to the generation of ROS. Preconditioning occurs in two phases: one rapid in onset that lasts for several hours and one delayed that requires transcription and translation of specific genes appearing in 18–24 h and persisting for several days (35). The phenomenon of preconditioning provides a clear demonstration that ischemia can effect fundamental biochemical alterations, specific to cardiac myocytes, and suggests that there may be biochemical targets specific to the myocardium that can be used to detect ischemia.

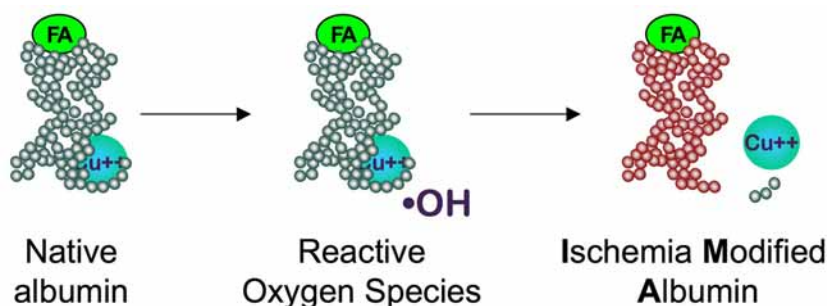
#### ISCHEMIA-MODIFIED ALBUMIN

To date, only one biochemical marker of ischemia has been approved by the Food and Drug Administration for the risk stratification of patients with suspected ACS. Nascent human serum albumin has multiple functions, including the ability to bind heavy metals at the N-terminal portion of the protein. The observations were made that not all albumin molecules have this metal-binding capability (36) and that in the presence of myocardial ischemia albumin may become altered; hence, this type of albumin was named ischemia-modified albumin (IMA) (Ischemia Technologies, Denver, CO) (37). The relative proportion of IMA increases significantly following the onset of myocardial ischemia and persists for approx 6–8 h (38,39). The initial hypothesis linked this change to ROS-induced damage to the N-terminus of albumin, which inactivated the heavy metal-binding site (Fig. 5). IMA is discussed in further detail in Chapter 13.

### *Myocardial Oxidative Metabolism*

#### TECHNETIUM-BASED MYOCARDIAL IMAGING

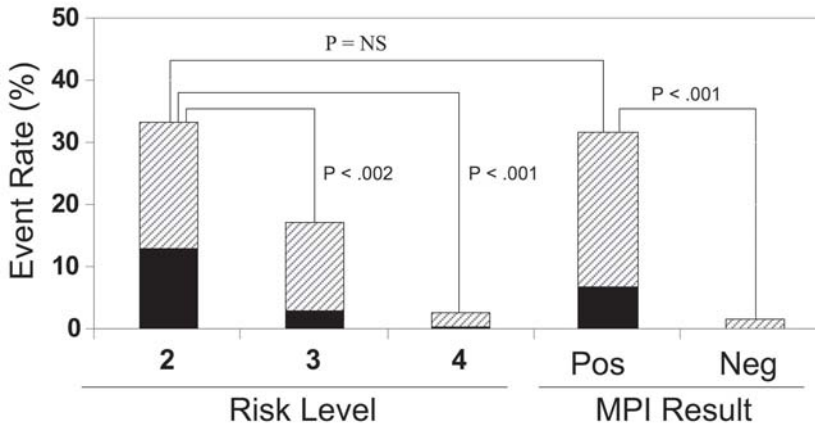
Cardiac specificity is vital for the decision-making process in the management of ACS and, thus, there is a need to identify biochemical alterations specific to the myocardium



**Fig. 5.** Ischemic modification to albumin: free-radical damage to N-terminus. Among the myriad functions for human serum albumin is the binding of a number of plasma constituents, including fatty acids (FA) and heavy metals such as copper ( $\text{Cu}^{++}$ ). There are a number of binding sites for the former, but the N-terminus appears to have a specific affinity for metal binding, which is susceptible to oxidant-induced damage. One proposed mechanism is that ROS such as hydroxyl radical ( $\cdot\text{OH}$ ) results in cleavage of a terminal peptide that abolishes the metal-binding capacity. This can be assayed by determining the binding capacity for cobalt, such as with the albumin-cobalt binding test, for detection of IMA.

(or coronary vasculature). Technetium-based myocardial perfusion agents may demonstrate one such alteration. Although used for imaging, these agents are functionally biochemical markers of ischemia: they require active transport at the plasma and mitochondrial membranes, and they require a functional electron-transport system in order to be bound. These agents thus reflect the status of oxidative metabolism in the cardiac myocyte. The information provided has very powerful diagnostic and prognostic value (Fig. 6) (27). Thus, using technetium-based MPI, we have identified a potential biochemical target—the status of oxidative metabolism—through which to document myocardial ischemia. However, the detector for this biochemical event is not an antibody or a colorimetric assay that can be used in a simple point-of-care device but, rather, a large, expensive scintigraphic camera requiring a significant level of computer processing and skill for interpretation. The potential advantages of developing a simple laboratory test to detect these biochemical events are obvious.

In addition, a potential for discordance between perfusion and functional imaging exists by virtue of the timing of these aspects of the test. One advantage to technetium-based agents is that their rapid uptake and retention allows perfusion images to be acquired several hours after injection, yet still reflect the perfusion status at the time of injection. Gated images, on the other hand, are acquired in real time and, thus, long delays between injection and imaging allow the possibility of finding abnormal perfusion with recovered wall motion. A similar discordance has been observed between pure perfusion imaging with thallium and metabolic imaging with iodine-123-labeled fatty acid analog,  $^{123}\text{I}$ -15 (*p*-iodophenyl)-3-(*R,S*)-methylpentadecanoic acid (BMIPP). BMIPP is taken up in proportion to blood flow (40) but is also dependent on intracellular fatty acid metabolism (41). The molecular structure of BMIPP prevents metabolism via  $\beta$ -oxidation but the vast majority is incorporated into the lipid pool via activation to BMIPP-CoA, which reflects intracellular adenosine triphosphate concentration. If  $\beta$ -oxidation is impaired, such as in the setting of ischemia, then the tracer is not converted and diffuses back out of the cell. There is a well-described delay in the recovery of oxidative metabolism that can last several hours to days. This “ischemic memory” is thought to be a correlate of myocardial stunning

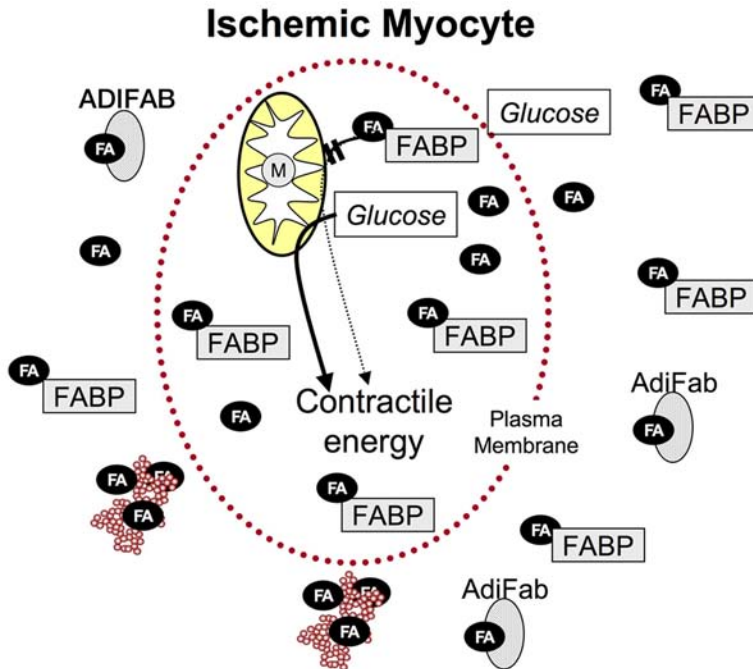


**Fig. 6.** Event rates categorized by clinical risk vs MPI. Primary risk stratification levels 2 (true unstable angina), 3 (probable unstable angina—higher risk nondiagnostic), and 4 (possible unstable angina—lower risk nondiagnostic) have decreasing event rates. The rates of AMI and revascularization are highest in level 2 patients relative to those in the lower-risk nondiagnostic levels 3 and 4. Secondary risk stratification using rest MPI is employed for level 3 and 4 patients (15 and 50%, respectively, of the chest pain population) to identify patients who are in fact at higher risk than appears from the initial risk stratification. An abnormal (Pos) MPI clearly identifies higher-risk individuals among this population, whereas a negative (Neg) MPI indicates very low risk. Solid bars represent AMI and hatched bars revascularization. Note that the total event rate associated with an abnormal MPI in level 3 and 4 patients is similar to the event rate for level 2. Thus, for patients who appear to be at lower risk based on history, physical examination, and ECG, a positive perfusion study carries equal probability of MI or urgent revascularization as does an ischemic ECG or other high-risk clinical features on the initial evaluation (27).

(42) and may prove valuable in the evaluation of chest pain (43). Thus, the ability to assess metabolism with the technetium agents and specific alterations in oxidative metabolism with BMIPP provides another avenue to detect myocardial ischemia. Can this metabolic alteration be assessed more simply using conventional biomarker technologies? The answer lies in the biochemistry of myocardial energetics.

### UNBOUND FREE FATTY ACIDS

The metabolic perturbations that occur during ischemia may suggest targets for marker development (Fig. 7). One such example is the detection of serum unbound free fatty acids (uFFA) by the high-affinity probe ADIFAB™, an acrylodated intestinal fatty acid-binding protein (FABP). The premise is that under normal circumstances serum albumin can essentially act as a buffer to sequester any uFFA not attached to FABPs, but under ischemic conditions there is an increase in FFA release, this buffering capacity is overwhelmed, and uFFA increases. Kleinfeld et al. (44) demonstrated a mean 14-fold increase following ischemia provoked by angioplasty, with the largest elevations occurring in those who also exhibited ECG changes during balloon inflation. Fatty acid accumulation may be owing to impaired utilization and uptake of FFA by the ischemic myocardium but may also occur through peripheral lipolysis activated indirectly secondary to ischemia, i.e., catecholamine release. It will certainly be interesting to determine whether there is a common relationship between the FFA and IMA models of ischemia detection.



**Fig. 7.** Simplistic overview of metabolic alterations in ischemic myocytes. Under oxidative conditions myocytes generate approx 70% of their energy via mitochondrial (M)  $\beta$ -oxidation of long-chain fatty acids (FA). Under hypoxic conditions,  $\beta$ -oxidation is inhibited and myocytes convert to a glucose-based metabolism. FAs that are normally carried by specific binding proteins (FABP) begin to accumulate and can be damaging to the cell if not somehow sequestered. Whether directly via a cardiac source or through some peripheral release mechanisms, FAs accumulate in the circulation. Initially they will bind to FABPs and to albumin, but when these sites are saturated, there will be an increase in unbound component, which can be detected quantitatively by the probe ADIFAB.

## CLINICAL CHALLENGES TO THE DEVELOPMENT OF ISCHEMIA MARKERS

### *Absence of a “Gold Standard”*

The single greatest impediment to the development of new markers for myocardial ischemia is the lack of a “gold standard.” Historically, the diagnosis of ischemia has been a clinical decision based on the history, physical examination, ECG, and aggregate of other tests performed and data acquired during the admission. It is fundamentally a clinical decision, and even in the absence of any hard end point or objective data such as elevated cardiac troponin or ECG changes, a diagnosis of ACS can still be rendered if the symptoms are strongly suspicious. On the other hand, there can be myocardial damage owing to causes other than ACS or ischemia, which can also complicate the diagnosis.

The challenge of evaluating a new more sensitive and specific marker relative to an imperfect gold standard was observed in the development of cardiac troponin. Katus et al. (45) initially reported the specificity of troponin T to be only 78% when compared to a creatine kinase-MB (CK-MB) standard for AMI. This conclusion was not congruent with the hypothesis that troponin T was highly cardiac specific relative to CK-MB. However, when patients with a clinical diagnosis of unstable angina were excluded, the sensitivity

<u>Negative</u>	Focus	<u>Positive</u>
Rule out	Goal	Rule in
Low	Prevalence	High
Low	Risk	High
High Sensitivity	Performance	High specificity
Throughput	Outcome	Appropriate care
Deferred cost	Financial basis	Incurred cost
Missed AMI	Error effect	Unneeded care

**Fig. 8.** Relative effects of negative vs positive tests for diagnosis of ACS. Most tests for ACS will result in clinical action based on test expectations. A test used in the ED to rule out ACS should be directed at lower-risk patients and have the expectation of high sensitivity. It should be used to manage ED throughput and the cost of the test should be weighed against the cost savings from deferring admission or performing other more expensive tests. If the result is wrong, the consequence of that error will be inappropriately discharging a potential AMI patient. However, if that test is “not negative,” and thereby assumed to be “positive,” any action taken on that basis could result in inappropriate care and unwarranted costs. The exact converse would occur for a rule-in test in a high-risk population who is not positive and on that basis is assumed to be “not negative.” This process is very much driven by the prevalence of disease in the population tested, which greatly affects clinical performance of a given test.

for troponin T was 95% (45). This finding was consistent among multiple early studies in which approximately one-third of patients with the clinical diagnosis of unstable angina were troponin positive and led to the argument that troponin could be used to diagnose unstable angina. The situation was not fully resolved until 2000, with the redefinition of AMI to a troponin standard (46). This slow evolution in the interpretation of troponin serves to illustrate the difficulty in determining both the sensitivity and specificity of an analyte when there is an imperfect gold standard: as Rosalki et al. (47) note, the original manuscripts on troponin T were “not accepted for publication by *Circulation* or by *Clinical Chemistry* because the isoenzymes of CK-MB were deemed to be the perfect marker and to remain the standard for AMI diagnosis.” A similar difficulty should be anticipated in the development of ischemia markers. Nevertheless, the potential for these markers to enhance diagnosis and risk assessment is demonstrated in patients who are ultimately diagnosed with MI among whom the initial troponin assay is negative but an ischemia marker such as FFA (48) or IMA (49) is already elevated.

### ***Rule-In vs Rule-Out Conundrum***

The performance expectations for a marker of ischemia will vary widely based on the intended application (Fig. 8). If the goal is to rule out ACS, then the performance bias will be toward sensitivity. On the other hand, if the goal is to establish the diagnosis (“rule in”) of ACS, then the bias must be toward specificity. Unfortunately, failure to rule in or failure to rule out are not events that occur in isolation. For instance, the goal in the ED is to diagnose and treat high-risk patients and to discharge low-risk patients. If a test to identify high risk is falsely negative (imperfect sensitivity), then a patient may not receive the appropriate treatment and in the worst-case scenario could be discharged, exposing the patient to

a higher probability of an adverse event, and subjecting the provider to potential liability. Conversely, in a low-risk patient if the test is falsely positive (imperfect specificity), then the patient may be subjected to unnecessary tests or procedures; prolonged hospitalizations; and, in some cases, an inappropriate diagnosis that could have significant psychosocial consequences.

In the absence of absolute sensitivity and specificity, these consequences are important considerations, and given the lack of a gold standard for ischemia, they will occur. As ischemia markers are developed, it will remain important to be very explicit regarding both their diagnostic performance and clinical expectations.

## CONCLUSION

Myocardial ischemia is itself associated with high risk, as demonstrated by ST-segment depression on an ECG (50), but progression to necrosis connotes even higher risk (51). To have the opportunity to prevent myocardial necrosis, one must be able to detect ischemia and intervene early.

It is possible to detect ischemia, but current methods are inadequate in some respects. Ischemic ECG changes are evanescent and thus lack the temporal characteristics necessary to provide an adequate level of sensitivity. Technetium-based MPI is sensitive and specific, but it is expensive, technologically challenging, logistically difficult and thus not widely available; BMIPP is even more interesting, will suffer the same limitations, and is not yet approved. Regional wall motion abnormalities can be indicators of ischemia, but, again, all imaging including echocardiography has significant limitations for implementation. Despite these shortcomings, all provide proof of principle that myocardial ischemia is both detectable and actionable.

Biochemical tests have historically been proven to be fast, accurate, simple to perform, relatively easy to interpret, and inexpensive. All of these characteristics are crucial for the informatics needed in the management of ACS and provide a strong argument for investing in the research and development of biochemical markers of myocardial ischemia. Nevertheless, there are many challenges to developing biomarkers of ischemia. The physiology is complex and is further complicated by the issues of chronicity, timing, and severity. The clinical context in which such biomarkers are to be used will be important as researchers evaluate their performance, and in the absence of a gold standard, comparative analyses will continue to be difficult to interpret. However, if successful, the payback will be tremendous in terms of improved patient safety, more appropriate clinical management, and improved outcomes. First-generation markers such as IMA and uFFA demonstrate considerable promise and provide a compelling case for further development.

## REFERENCES

1. Pope JH, Aufderheide TP, Ruthazer R, et al. Missed diagnoses of acute cardiac ischemia in the emergency department. *N Engl J Med* 2000;342:1163–1170.
2. Gibler WB, Runyon JP, Levy RC, et al. A rapid diagnostic and treatment center for patients with chest pain in the emergency department. *Ann Emerg Med* 1995;25:1–8.
3. Graff LG, Dallara J, Ross MA, et al. Impact on the care of the emergency department chest pain patient from the chest pain evaluation registry (CHEPER) study. *Am J Cardiol* 1997;80:563–568.
4. Jesse RL, Kontos MC, Roberts CS. Diagnostic strategies for the evaluation of the patient presenting with chest pain. *Prog Cardiovasc Dis* 2004;46:417–437.
5. Braunwald E, Antman EM, Beasley JW, et al. ACC/AHA 2002 guideline update for the management of patients with unstable angina and non-ST-segment elevation myocardial infarction—summary article:



- a report of the American College of Cardiology/American Heart Association task force on practice guidelines (Committee on the Management of Patients with Unstable Angina). *J Am Coll Cardiol* 2002;40:1366–1374.
6. Pollack CVJ, Roe MT, Peterson ED. 2002 update to the ACC/AHA guidelines for the management of patients with unstable angina and non-ST-segment elevation myocardial infarction: implications for emergency department practice. *Ann Emerg Med* 2003;41:355–369.
  7. Antman EM, Anbe DT, Armstrong PW, et al. ACC/AHA guidelines for the management of patients with ST-elevation myocardial infarction—executive summary. A report of the American College of Cardiology/American Heart Association Task Force on Practice Guidelines (Writing Committee to revise the 1999 guidelines for the management of patients with acute myocardial infarction). *J Am Coll Cardiol* 2004;44:671–719.
  8. Gomez MA, Anderson JL, Karagounis LA, Muhlestein JB, Mooers FB. An emergency department-based protocol for rapidly ruling out myocardial ischemia reduces hospital time and expense: results of a randomized study (ROMIO). *J Am Coll Cardiol* 1996;28:25–33.
  9. Roberts RR, Zalenski RJ, Mensah EK, et al. Costs of an emergency department-based accelerated diagnostic protocol vs hospitalization in patients with chest pain: a randomized controlled trial. *JAMA* 1997;278:1670–1676.
  10. Farkouh ME, Smars PA, Reeder GS, et al. A clinical trial of a chest-pain observation unit for patients with unstable angina. Chest Pain Evaluation in the Emergency Room (CHEER) Investigators. *N Engl J Med* 1998;339:1882–1888.
  11. Joseph AJ, Cohen AG, Bahr RD. A formal, standardized and evidence-based approach to Chest Pain Center development and process improvement: the Society of Chest Pain Centers and Providers accreditation process. *J Cardiovasc Manage* 2003;14:11–14.
  12. Fuster V, Badimon L, Badimon JJ, Chesebro JH. The pathogenesis of coronary artery disease and the acute coronary syndromes (1). *N Engl J Med* 1992;326:242–250.
  13. Fuster V, Badimon L, Badimon JJ, Chesebro JH. The pathogenesis of coronary artery disease and the acute coronary syndromes (2). *N Engl J Med* 1992;326:310–318.
  14. Alpert JS, Thygesen K, Bassand JP, et al. Myocardial infarction redefined—a consensus document of the Joint European Society of Cardiology/American College of Cardiology Committee for the redefinition of Myocardial Infarction. *J Am Coll Cardiol* 2000;36:959–969.
  15. Goldman L, Cook EF, Brand DA, et al. A computer protocol to predict myocardial infarction in emergency department patients with chest pain. *N Engl J Med* 1988;318:797–803.
  16. Selker HP, Beshansky JR, Griffith JL, et al. Use of the acute cardiac ischemia time-insensitive predictive instrument (ACI-TIPI) to assist with triage of patients with chest pain or other symptoms suggestive of acute cardiac ischemia: a multicenter, controlled clinical trial. *Ann Intern Med* 1998;129:845–855.
  17. Pozen MW, D’Agostino RB, Mitchell JB, et al. The usefulness of a predictive instrument to reduce inappropriate admissions to the coronary care unit. *Ann Intern Med* 1980;92:238–242.
  18. Lee TH, Rouan GW, Weisberg MC, et al. Clinical characteristics and natural history of patients with acute myocardial infarction sent home from the emergency room. *Am J Cardiol* 1987;60:219–224.
  19. Karcz A, Korn R, Burke MC, et al. Malpractice claims against emergency physicians in Massachusetts: 1975–1993. *Am J Emerg Med* 1996;14:341–345.
  20. Antman EM, Tanasijevic MJ, Thompson B, et al. Cardiac-specific troponin I levels to predict the risk of mortality in patients with acute coronary syndromes. *N Engl J Med* 1996;335:1342–1349.
  21. Lee TH, Cook EF, Weisberg M, Sargent RK, Wilson C, Goldman L. Acute chest pain in the emergency room: identification and examination of low-risk patients. *Arch Intern Med* 1985;145:65–69.
  22. Fesmire FM, Percy RF, Bardoner JB, Wharton DR, Calhoun FB. Usefulness of automated serial 12-lead ECG monitoring during the initial emergency department evaluation of patients with chest pain. *Ann Emerg Med* 1998;31:3–11.
  23. Zalenski RJ, Cooke D, Rydman R, Sloan EP, Murphy DG. Assessing the diagnostic value of an ECG containing leads V4R, V8, and V9: the 15-lead ECG. *Ann Emerg Med* 1993;22:786–793.
  24. Kornreich F, Montague TJ, Rautaharju PM. Body surface potential mapping of ST segment changes in acute myocardial infarction: implications for ECG enrollment criteria for thrombolytic therapy. *Circulation* 1993;87:773–782.
  25. Amsterdam EA, Kirk JD, Diercks DB, Lewis WR, Turnipseed SD. Immediate exercise testing to evaluate low-risk patients presenting to the emergency department with chest pain. *J Am Coll Cardiol* 2002;40:251–256.
  26. Klocke FJ, Baird MG, Lorell BH, et al. ACC/AHA/ASNC guidelines for the clinical use of cardiac radionuclide imaging—executive summary: a report of the American College of Cardiology/American Heart

- Association Task Force on Practice Guidelines (ACC/AHA/ASNC Committee to Revise the 1995 Guidelines for the Clinical Use of Cardiac Radionuclide Imaging). *Circulation* 2003;108:1404–1418.
27. Kontos MC, Jesse RL, Anderson FP, Schmidt KL, Ornato JP, Tatum JL. Comparison of myocardial perfusion imaging and cardiac troponin I in patients admitted to the emergency department with chest pain. *Circulation* 1999;99:2073–2078.
  28. Heller GV, Stowers SA, Hendel RC, et al. Clinical value of acute rest technetium-99m tetrofosmin tomographic myocardial perfusion imaging in patients with acute chest pain and nondiagnostic electrocardiograms. *J Am Coll Cardiol* 1998;31:1011–1017.
  29. Hilton TC, Thompson RC, Williams HJ, Saylor R, Fulmer H, Stowers SA. Technetium-99m sestamibi myocardial perfusion imaging in the emergency room evaluation of chest pain. *J Am Coll Cardiol* 1994; 23:1016–1022.
  30. Tatum JL, Jesse RL, Kontos MC, et al. Comprehensive strategy for the evaluation and triage of the chest pain patient. *Ann Emerg Med* 1997;29:116–123.
  31. Kontos MC, Jesse RL, Schmidt KL, Ornato JP, Tatum JL. Value of acute rest sestamibi perfusion imaging for evaluation of patients admitted to the emergency department with chest pain. *J Am Coll Cardiol* 1997;30:976–982.
  32. Fintel DJ, Ledley GS. Management of patients with non-ST-segment elevation acute coronary syndromes: insights from the PURSUIT trial. *Clin Cardiol* 2000;23:1–12.
  33. Stocker R, Keaney JF Jr. Role of oxidative modifications in atherosclerosis. *Physiol Rev* 2004;84(4): 1381–1478.
  34. Holvoet P, Collen D, Van de Werf F. Malondialdehyde-modified LDL as a marker of acute coronary syndromes. *JAMA* 1999;281:1718–1721.
  35. Eisen A, Fisman EZ, Rubenfire M, et al. Ischemic preconditioning: nearly two decades of research: a comprehensive review. *Atherosclerosis* 2004;172:201–210.
  36. Bar-Or D, Lau E, Rao N, Bampos N, Winkler JV, Curtis CG. Reduction in the cobalt binding capacity of human albumin with myocardial ischemia [abstract]. *Ann Emerg Med* 1999;34:4.
  37. Christenson RH, Duh SH, Sanhai WR, et al. Characteristics of an albumin cobalt binding test for assessment of acute coronary syndrome patients: a multicenter study. *Clin Chem* 2001;47(3):464–470.
  38. Sinha MK, Gaze DC, Tippins JR, Collinson PO, Kaski JC. Ischemia modified albumin is a sensitive marker of myocardial ischemia after percutaneous coronary intervention. *Circulation* 2003;107:2403–2405.
  39. deFilippi C, Yoon S, Bounds C, et al. Early detection of myocardial ischemia by a novel blood-based biomarker: the kinetics of ischemia modified albumin. *J Am Coll Cardiol* 2003;41(6) (Suppl A):402A.
  40. Reinhardt CP, Weinstein H, Leppo JA. Comparison of iodine-125-BMIPP and thallium-201 in myocardial hypoperfusion. *J Nucl Med* 1995;36(9):1645–1653.
  41. Takeda K, Saito K, Makino K, et al. Iodine-123-BMIPP myocardial washout and cardiac work during exercise in normal and ischemic hearts. *J Nucl Cardiol* 1997;38(4):559–563.
  42. Naruse H, Ariei T, Kondo T, et al. Clinical usefulness of iodine 123-labeled fatty acid imaging in patients with acute myocardial infarction. *J Nucl Cardiol* 1998;5(3):275–284.
  43. Kawai Y, Tsukamoto E, Nozaki Y, Morita K, Sakurai M, Tamaki N. Significance of reduced uptake of iodinated fatty acid analogue for the evaluation of patients with acute chest pain. *J Am Coll Cardiol* 2001; 38(7):1888–1894.
  44. Kleinfeld AM, Prothro D, Brown DL, Davis RC, Richieri GV, DeMaria A. Increases in serum unbound free fatty acid levels following coronary angioplasty. *Am J Cardiol* 1996;78:1350–1354.
  45. Katus HA, Remppis A, Neumann FJ, et al. Diagnostic efficiency of troponin T measurements in acute myocardial infarction. *Circulation* 1991;83:902–912.
  46. Alpert JS, Thygesen K, Antman E, Bassand JP. Myocardial infarction redefined—a consensus document of the Joint European Society of Cardiology/American College of Cardiology Committee for the Redefinition of Myocardial Infarction. *J Am Coll Cardiol* 2000;36:959–969.
  47. Rosalki SB, Roberts R, Katus HA, Giannitsis E, Ladenson JH. Cardiac biomarkers for detection of myocardial infarction: perspectives from past to present. *Clin Chem* 2004;50(11):2205–2213.
  48. Apple FS, Kleinfeld AM, Adams J III. Unbound free fatty acid concentrations are increased in cardiac ischemia. *Clin Proteomics* 2004;1:41–44.
  49. Abadie JM, Blassingame CL, Bankson DD. Albumin cobalt binding assay to rule out acute coronary syndrome. *Ann Clin Lab Sci* 2005;35:66–72.
  50. Armstrong PW, Fu Y, Chang WC, et al. Acute coronary syndromes in the GUSTO-IIb trial: prognostic insights and impact of recurrent ischemia. The GUSTO IIb Investigators. *Circulation* 1998;98:1860–1868.
  51. Galvani M, Ottani F, Ferrini D, et al. Prognostic influence of elevated values of cardiac troponin I in patients with unstable angina. *Circulation* 1997;95:2053–2059.

52. Selker HP, Griffith JL, Dorey FJ, D'Agostino RB. How do physicians adapt when the coronary care unit is full? A prospective multicenter study. *JAMA* 1987;257:1181–1185.
53. Puleo PR, Meyer D, Wathen C, et al. Use of a rapid assay of subforms of creatine kinase-MB to diagnose or rule out acute myocardial infarction. *N Engl J Med* 1994;331:561–566.
54. Rouan GW, Hedges JR, Toltzis R, Goldstein-Wayne B, Brand D, Goldman L. A chest pain clinic to improve the follow-up of patients released from an urban university teaching hospital emergency department. *Ann Emerg Med* 1987;16:1145–1150.
55. Tierney WM, Fitzgerald J, McHenry R, et al. Physicians' estimates of the probability of myocardial infarction in emergency room patients with chest pain. *Med Decis Making* 1986;6:12–17.

# 13

---

## Emerging Biomarkers of Myocardial Ischemia

---

*Jesse E. Adams, MD, FACC*

### *CONTENTS*

INTRODUCTION

LIMITATIONS TO TRADITIONAL DIAGNOSTIC TESTING FOR ACS

IDENTIFICATION OF CANDIDATE MARKERS OF MYOCARDIAL ISCHEMIA

INDIVIDUAL ANALYTES

CONCLUSION

REFERENCES

---

### SUMMARY

Myocardial ischemia has a complex pathophysiology and can manifest with a multitude of clinical presentations, including without symptoms. Patients who present to the emergency department with a complaint of chest pain therefore require substantial diagnostic effort to determine whether their symptoms are related to acute myocardial ischemia. Present diagnostic approaches are typically protocol driven and include serial electrocardiograms and biomarkers obtained over an 8- to 12-h period for the detection of myocardial necrosis. This paradigm is reasonably effective in identifying patients who have acute coronary syndrome, especially when there is associated myocardial necrosis, but it offers only modest sensitivity and relies heavily on biomarkers that are increased only in the presence of irreversible myocardial injury (i.e., necrosis). For this reason, there has been intense research and clinical interest in the development of sensitive biomarkers of myocardial ischemia that are not dependent on the presence of myocardial necrosis. Markers investigated for this purpose include ultrasensitive troponin, ischemi-modified albumin, sCD40L, myeloperoxidase, glutathione peroxidase, nourins, unbound free fatty acid, and whole-blood choline. Despite the emergence of these candidate markers of ischemia, currently there is not sufficient evidence to recommend widespread adoption of any of them into clinical practice.

**Key Words:** Ischemia; unstable angina; biomarkers; myocardial infarction; prognosis.

From: *Contemporary Cardiology:  
Cardiovascular Biomarkers: Pathophysiology and Disease Management*  
Edited by: David A. Morrow © Humana Press Inc., Totowa, NJ

Table 1  
Potential Mechanisms of Ischemia and Acute Coronary Syndrome (ACS)

- 
- Plaque rupture with acute thrombosis
  - Mechanical obstruction owing to progressive epicardial coronary artery stenosis
  - Inflammation
  - Secondary causes of ACS
  - Vasospastic coronary stenosis
- 

## INTRODUCTION

As discussed in the previous chapter, the pathophysiology of ischemia is complex, and myocardial ischemia can manifest with a multitude of clinical presentations, including without symptoms. Patients who present to the emergency department (ED) with a complaint of chest pain or anginal equivalent therefore undergo a series of evaluations to determine whether their symptoms are related to acute myocardial ischemia. Five principal etiologies of acute coronary syndrome (ACS) have been described:

1. Plaque rupture with acute thrombosis.
2. Mechanical obstruction owing to progressive epicardial coronary artery stenosis.
3. Inflammation.
4. Secondary causes of ACS.
5. Vasospastic coronary stenosis (Table 1) (1).

The most common of these is rupture of vulnerable plaque and consequent thrombus formation (*see* Chapter 12, Fig. 3). The optimal diagnostic paradigm would enable the accurate differentiation not only of those patients with and without myocardial ischemia as the cause of their symptoms, but also the principal underlying cause, allowing the proper therapeutic choices to be made.

Present diagnostic approaches are typically protocol driven and include serial electrocardiograms (ECGs) and biomarkers obtained over an 8- to 12-h period for the detection of myocardial necrosis (2). This paradigm is reasonably effective in identifying patients who have ACS, especially when there is associated myocardial necrosis, but there are a number of limitations to this strategy (3,4). Foremost, the traditional clinical tools for the diagnosis of ACS offer only modest sensitivity and rely heavily on biomarkers that are increased only in the presence of irreversible myocardial injury (i.e., necrosis). For this reason, there has been intense research and clinical interest in the development of sensitive biomarkers of myocardial ischemia that are not dependent on the presence of myocardial necrosis.

## LIMITATIONS TO TRADITIONAL DIAGNOSTIC TESTING FOR ACS

The evaluation and selection of candidate markers of myocardial ischemia require an understanding of the performance of the current diagnostic tools. More important, the standard tools, including the clinical history, examination, ECG, and biomarkers of necrosis, are limited by imperfect sensitivity and modest specificity. In a study of 5951 patients who presented to the ED for evaluation of nontraumatic chest pain, 2 to 3% of the patients with an acute myocardial infarction (AMI) and 8% of those with unstable angina were erroneously sent home (3). In addition, 59% of those hospitalized were discharged with diag-

noses other than ACS. Based on a prevalence of disease in this population of 21.9%, the clinical diagnostic performance of the ED using standard tools was characterized by a sensitivity of 93.8%, specificity of 40.1%, positive predictive value of 32.7%, and negative predictive value of 95%.

## IDENTIFICATION OF CANDIDATE MARKERS OF MYOCARDIAL ISCHEMIA

Efforts to develop sensitive and specific biomarkers of ischemia have been confronted with substantial challenges. The term *ischemia* itself is often used imprecisely and is also used differently by clinicians and biochemists. In normal conditions, the heart is well oxygenated and generates approx 70% of its energy stores from fatty acids and to a lesser extent lactate (5). Cellular ischemia develops in the setting of an insufficient supply of oxygenated blood to meet cardiac demands. Local lactate concentrations rise rapidly owing to the necessary shift from mitochondrial oxygenation to glycolysis for generation of adenosine triphosphate (ATP). Cellular and interstitial acidosis develops with the generation of two hydrogen ions for each molecule of glucose consumed via glycolysis. With the onset of ischemia, cardiac metabolism and contraction is altered owing to both a sudden drop in available ATP and the onset of cellular acidosis. In the early stages of ischemia, irreversible myocyte injury and the consequent release of cellular structural proteins such as troponin does not occur. However, the intracellular biochemical changes and their local consequences, if detectable, might serve as biological markers of ischemia.

By contrast, clinicians do not typically define ischemia based on specific cellular changes but, rather, use the term to describe clinical scenarios. This clinical focus also provides direction for the discovery of candidate biomarkers associated with the onset of myocardial ischemia. Some investigators have pursued candidate proteins released during the events leading to and culminating in ACS, including plaque disruption or plaque erosion, acute thrombosis, and downstream ischemia owing to both diminished blood flow and the downstream elaboration of platelet aggregates, thrombin, and activated leukocytes. Others have focused on disease states marked by mismatch between supply and demand owing to fixed underlying mechanical obstruction in the absence of acute plaque rupture and thrombosis. It is notable that the pathobiology pertinent to the development of ischemia in these different clinical situations is divergent, and, therefore, diagnostic analytes identified in these specific settings may provide performance characteristics that are situationally dependent. For example, biomarkers originating from a clinical focus on the pathophysiology of ACS are not likely to reflect ischemia *per se* but, rather, events tied closely to acute atherothrombosis, the most common precipitant of acute myocardial ischemia. Such biomarkers are discussed in this chapter in the context of application as diagnostic markers for unstable angina.

Originating from these pathophysiological foundations, a number of candidate biomarkers of ischemia/ACS have been proposed (Table 2). Before moving toward consideration of clinical implementation, each of these candidates must be evaluated critically with respect to key biochemical and clinical characteristics (Table 3). Moreover, for an analyte to be useful to clinicians, it must fulfill requirements necessary to establish the biomarker's value as a clinical tool, and to guide appropriate clinical application (Table 4). Although none of the putative markers of ischemia/ACS has yet been shown to meet all of these requirements, several have emerged as potential viable candidates and remain the subject of ongoing research.

Table 2  
Potential Markers of Ischemia

---

- C-reactive protein
- Cardiac troponins
- CD40L
- Choline
- Glutathione peroxidase 1
- Ischemia-modified albumin
- Myeloperoxidase
- Natriuretic peptides (B-type natriuretic peptide [BNP] and proBNP)
- Nourins
- Pregnancy-associated plasma protein-A
- Unbound free fatty acid

---

Table 3  
Basic Requirements to Evaluate Diagnostic Markers of Ischemia

---

- I. Knowledge of basic aspects of the analyte
  - a. Biological mechanism(s)
  - b. Rate of rise
  - c. Duration of elevation
  - d. Mechanism of clearance
  - e. Data on nonischemic etiologies of analyte positivity
    1. Biological false positives
    2. Analytic false positives
  - f. Assay and sample requirements
- II. Low coefficient of variation
- III. Definition of diagnostic performance
  - a. Defined for each patient population
    1. Sensitivity
    2. Specificity
    3. Negative predictive value
    4. Positive predictive value

---

## INDIVIDUAL ANALYTES

### *Sensitive Markers of Myocardial Injury*

Cardiac troponin is a structural protein in myocytes that is released in the setting of irreversible cellular injury and serves as the cornerstone for the diagnosis of MI (6,7). Although it is consensus that troponin is detectable using present-generation assays only in the setting of irreversible injury (7), it remains possible that with the emergence of “ultrasensitive” assays for cardiac troponin small amounts of the protein that may be released during reversible injury (ischemia) will become measurable. For example, studies using proteomic techniques have shown that cardiac troponin is present in the circulation of patients who present with ACS and in whom there is no detectable troponin elevation using commercially available assays (8). Moreover, circulating troponin can be documented by this method well before the typical 4–6 h required to reach concentrations detectable using commercial assays. Finally, the discovery of posttranslational modifications of troponin that may occur in settings specific to the etiology of injury, and very early during the course of ischemia, may lead to new applications for cardiac troponin as a marker of ischemia.

Table 4  
Requirements for Marker of Ischemia

- 
- Is present with ischemia
  - Adds independent information
  - Provides prognostic information
  - Guides additional diagnostic testing
  - Guides therapeutic decisions
  - Has high sensitivity with reasonable specificity
  - Appears rapidly in circulation after onset of ischemia
  - Has rapid assay turnaround time
  - Has robust analytic assay
  - Has reasonable cost
  - Has presence (or absence) of analyte in various types of ischemia (*see Table 1*)
- 

### *Markers of Plaque Vulnerability, Rupture, and Thrombosis*

#### **C-REACTIVE PROTEIN**

C-reactive protein (CRP) is a hepatically derived pentraxin that serves as the prototypic acute-phase reactant; it has been extensively evaluated for detection of cardiac risk (9). Most studies of CRP have focused on its ability to augment risk assessment for both primary and secondary prevention of cardiovascular events. However, in addition to these uses of CRP, studies have also evaluated CRP in the context of acute presentation with chest discomfort. CRP is elevated in some patients with unstable angina, i.e., in the absence of myocardial necrosis (10), and is associated with a higher risk of fatal complications in that setting (11). However, the concentration of CRP does not increase predictably in the first 96 h after the development of ischemia and does not appear to correlate with the number and duration of ischemic episodes (10). Thus, although CRP and other nonspecific markers of inflammation may serve as early markers of atherothrombosis in some settings, the majority of markers in this class are not likely to confer sufficient specificity for ischemia itself to be useful as a biomarker for its diagnosis. Nevertheless, biomarkers with greater specificity for acute changes within the vulnerable coronary atheroma maintain potential as diagnostic markers for ACS.

#### **SOLUBLE CD40 LIGAND**

CD40 ligand (CD40L) is a trimeric transmembrane protein that is related to tumor necrosis factor- $\alpha$  (TNF- $\alpha$ ) and is present on endothelial cells, monocytes, macrophages, and platelets. It is present already synthesized and is available for release within seconds of the appropriate stimulus. Surface-expressed CD40L is cleaved and persists in the circulation for hours as the active form, sCD40L (12). More than 90% of the sCD40L present in the circulation is derived from platelets, and sCD40L additionally acts as a platelet agonist, thus serving to upregulate platelet activation while weaving platelet activation into further stimulation of the inflammatory cascade (13). A rapid rise in the concentration of sCD40L is thus likely to occur at the time of plaque rupture and thrombosis.

The concentration of sCD40L is elevated in patients with unstable angina and is associated with the risk of death and recurrent ischemic events (14,15). However, as is the case for CRP, this analyte appears to provide primarily prognostic, rather than robust, diagnostic information. In studies of sCD40L in ACS, levels of this biomarker were elevated in <50% of the population (14,15). This finding can be anticipated from its mechanism



of release, which is not expected to be present in all patients with ischemia, but may serve to identify those in whom platelet activation and thrombosis is a major contributor.

### MYELOPEROXIDASE

Myeloperoxidase (MPO) is a leukocyte enzyme secreted during neutrophil activation that has been implicated in the disruption of atherosclerotic plaques and has been shown to be present in increased concentrations within ruptured compared with stable atheroma. Blood obtained from patients presenting with AMI has levels of MPO that are fourfold higher than that of control patients (16). Among patients with ACS, there is poor correlation between the concentrations of MPO and troponin, soluble CD40L, or CRP (17), suggesting that MPO is not simply a marker of necrosis, platelet activation, or inflammation. A strong association between MPO and the risk of major cardiac events was apparent in at least two studies (17,18). The diagnostic utility of MPO has been proposed based on evidence that it may be a very early marker of plaque destabilization (18). Consistent with this hypothesis, in a study of patients with suspected ACS, MPO was elevated at presentation in a larger proportion of patients than cardiac troponin and preceded elevation of troponin in many who went on to manifest diagnostic criteria for MI (18). Nevertheless, this application requires further study, particularly in populations with low prevalence of disease.

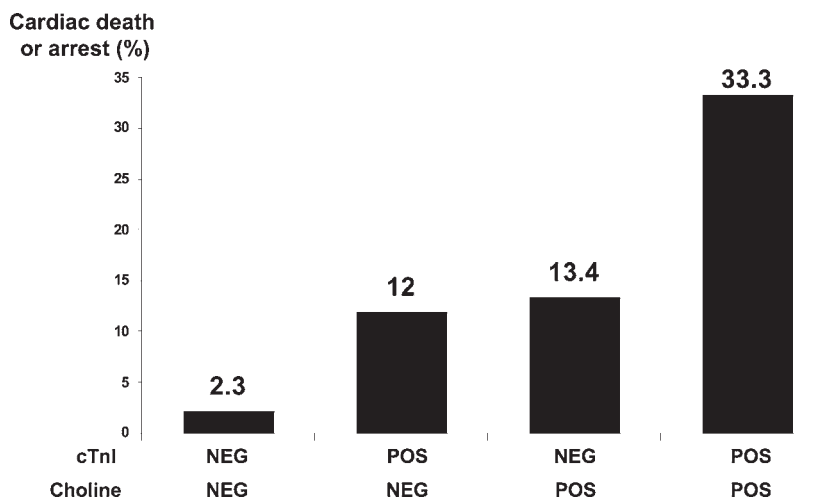
### PREGNANCY-ASSOCIATED PLASMA PROTEIN A

Pregnancy-associated plasma protein-A (PAPP-A) is a metalloproteinase that is expressed in atherosclerotic plaque. Increasing levels of PAPP-A appear to correlate with increasing plaque instability, as well as plaque complexity (19,20). In patients with ACS, the concentration of PAPP-A is elevated in up to two-thirds of patients, rising variably from as early as 2 h or as late as 30 h after the apparent onset of ACS. Moreover, in a study of 200 serial patients with ACS, levels of PAPP-A were independently associated with an increased risk of cardiovascular events (21). When studied as a diagnostic marker for ACS, receiver operator curve analysis supported an optimal cutoff value for PAPP-A of 0.22 mIU/L, with a sensitivity of 66.7% and a specificity of 51.1%. Interestingly, in this population the sensitivity of cardiac troponin T at presentation was also 51.5%, with a specificity of 82.1% (22).

### WHOLE-BLOOD CHOLINE

Choline is the major enzyme product of phospholipase D, a protein that it is stimulated by the activation of cell-surface receptors on leukocytes and platelets and that appears to be involved in signal transduction during events that lead to plaque destabilization (23, 24). Using nuclear magnetic resonance spectroscopy of whole-blood ultrafiltrates to screen for novel markers associated with ACS, Wevers et al. (25) identified choline as a marker consistently present in the circulation in this setting. In a subsequent clinical study involving 327 patients with ACS, 250 of whom were troponin negative, levels of choline (divided into quartiles) were shown to correlate with the 30-d risk of death, heart failure, and cardiac arrest (Fig. 1) (26). More important, this prognostic relationship was also apparent in the subgroup of patients without elevated levels of cardiac troponin.

However, in the same study, levels of choline were not consistently elevated in patients with MI, and the mean values for patients with noncardiac chest pain ( $19.4 \pm 6.8 \mu\text{mol/L}$ ) were not substantially different from those with low-risk unstable angina ( $24.5 \pm 15 \mu\text{mol/L}$ ). Although the half-life of whole-blood choline in patients with ACS has not yet been defined, it is noteworthy that the highest sensitivity of this analyte was observed with the admission blood sample, implying a short diagnostic half-life and also suggesting that use of



**Fig. 1.** Risk of cardiac death or arrest stratified by results of testing for choline and cardiac troponin. (Data from ref. 26.)

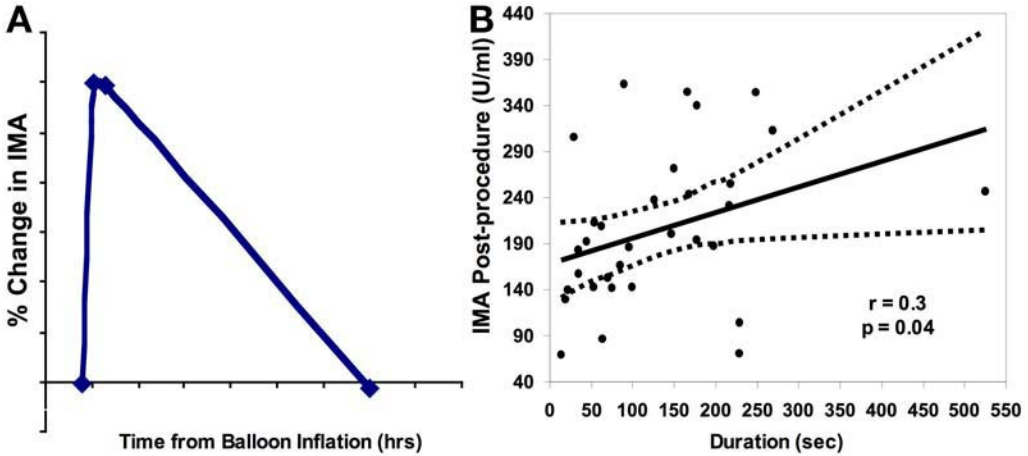
whole-blood choline may be limited in patients who present long after their episode of chest discomfort. Further studies will be necessary to evaluate the diagnostic application of this novel marker.

### *Biomarkers Related to Local Reactions During Ischemia*

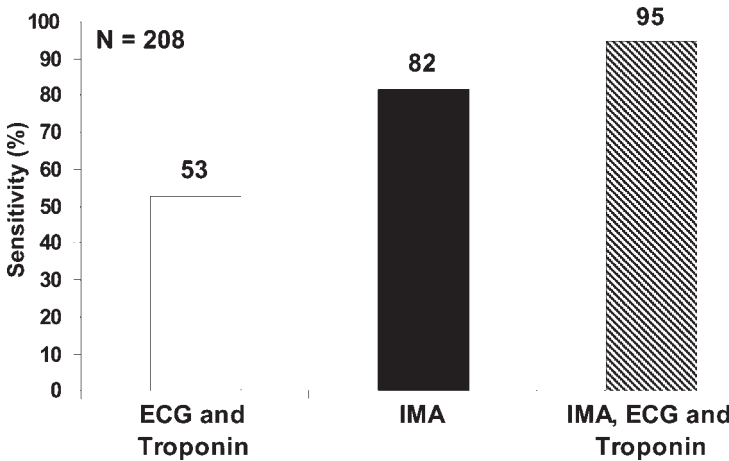
#### ISCHEMIA-MODIFIED ALBUMIN

Bar-Or et al. (27) made the original observation that the N-terminus of albumin is modified in the setting of myocardial ischemia. Normal albumin (a 66.7-kDa serum protein) binds cobalt (and other transitional metals) at the N-terminus. However, in the setting of ischemia, the affinity for transitional metals is reduced. When cobalt is added to a sample of serum containing ischemia-modified albumin (IMA), less of the cobalt is bound proportional to the amount of IMA present in the sample. Although the precise mechanisms for production of IMA during coronary ischemia are not known, the changes have been localized to modifications of the *N*-Asp-Ala-His-Lys sequence of human albumin and are proposed to be related to production of free radicals during ischemia and/or reperfusion, reduced oxygen tension, acidosis, and cellular alterations such as disruption of sodium and calcium pump function (28–30).

Initial studies suggest that the modification of albumin occurs rapidly after the onset of ischemia. Clinical studies of patients undergoing angioplasty show that levels of IMA rise rapidly after balloon inflation and return to normal by 12 h (28,30) (see Fig. 2). When evaluated in patients presenting to the ED with nontraumatic chest pain, IMA significantly improves the sensitivity of diagnostic testing for ACS using the ECG and troponin at presentation (Fig. 3). However, the specificity of IMA testing has consistently been low (approx 30%) (27,31). On the basis of these data, IMA has been approved by the Food and Drug Administration for use in conjunction with the ECG and cardiac troponin for the exclusion of ACS in patients felt to be at low to intermediate risk for myocardial ischemia. A negative result paired with serial negative troponin and electrocardiographic data yields a very low posttest likelihood of disease. However, the low specificity of the analyte has the potential to result in numerous false positives, with more false positive than true positive



**Fig. 2.** Concentration of IMA after ischemia during percutaneous coronary angioplasty. (A) Temporal course. (Data from ref. 30.) (B) Adapted from ref. 27.



**Fig. 3.** Sensitivity of IMA measured at presentation for ACS as determined by physician’s diagnosis at discharge. (Data from ref. 31.)

results when applied in populations with low prevalence of disease. Additional investigation will be valuable in clarifying the appropriate clinical role for IMA in diagnosis, risk stratification, and therapeutic decision making for patients with possible ACS.

**GLUTATHIONE PEROXIDASE**

Glutathione peroxidase 1 activity has been investigated as a potential marker of ischemia and atherosclerosis. Glutathione peroxidase 1 is a cellular antioxidant enzyme that protects against reactive oxygen species. Glutathione peroxidase 1 activity appears to be significantly decreased in patients presenting with AMI compared with a healthy population (32). In addition, in a study involving 643 patients (133 with unstable angina and 510 with stable angina), levels of glutathione peroxidase 1 were found to be inversely proportional to the future risk of cardiovascular disease, in patients with both stable angina and unstable angina (33). When adjusted for age and sex, the marker exhibited an inverse relationship to future

cardiovascular events (death or MI) over 4.7 yr of follow-up. Nevertheless, the application of glutathione peroxidase 1 for the diagnosis of ACS is yet to be established.

### *Other Biomarkers of the Myocardial Response to Ischemia*

#### **UNBOUND FREE FATTY ACIDS**

Fatty acids are the major energy substrate for myocardium and are predominantly stored intracellularly. Of those fatty acids found in circulation, the majority are bound to positively charged proteins (especially albumin), whereas a small percentage (<1%) of the fatty acid in circulation is unbound. The concentration of unbound free fatty acid (uFFA) in circulation increases in response to mediators released rapidly after the onset of ischemia, such as catecholamines, CRP, TNF- $\alpha$ , or natriuretic peptides. Levels of uFFA rise within 30 min after ischemia induced by coronary angioplasty (34) and are markedly increased at presentation in patients with acute ST-segment elevation myocardial infarction (STEMI) (35). In the latter population with ACS, the concentration of uFFA was associated with the risk of recurrent MI, coronary artery bypass graft (CABG), and death. Data from the Eptifibatide for Acute Coronary Syndromes-Rapid Versus Late Administration for Therapeutic Yield (EARLY) trial (a randomized trial of patients with unstable angina and non-STEMI) showed that 96.9% of patients had abnormal levels of uFFA at the baseline sample. When these levels were combined with cardiac troponin T, 99.7% of patients were identified on the baseline sample alone (36). Additional investigation of this marker in less selected populations presenting with chest pain and with earlier sampling is necessary before any potential clinical application can be considered.

#### **NOURINS**

Nourins are small heat-labile 3-kDa peptides that are released by various tissues, with nourin-1 being released by myocardial cells, in response to stresses such as ischemia, physical trauma, chemicals, and infectious agents. Nourin is a chemotactic factor for neutrophils and stimulates the release of interleukin (IL)-1, IL-8, and TNF- $\alpha$ . Nourins also appear to stimulate the secretion of adhesion molecules, neutrophils, and endothelial cells (37). Nourin-1 appears to be released rapidly—within 5 min of the onset of ischemia—and can be separated from other nourin peptides (38). Nourin-1 is measured by a neutrophil migration chemotactic assay. Preliminary studies have indicated that nourin is elevated after CABG in dogs and humans, after coronary artery occlusion in dogs, and in patients ( $n = 10$ ) with ACS (39). Development of a clinically useful assay and increased patient enrollment into trials of ACS will be necessary to ascertain the potential clinical utility of this analyte.

### **CONCLUSION**

The search for an effective biomarker of myocardial ischemia remains a high scientific priority. Despite the emergence of multiple candidate markers for the detection of ischemia and/or diagnosis of ACS, as yet, none of these has sufficient evidence to recommend widespread adoption into clinical practice.

### **REFERENCES**

1. Hamm CW, Braunwald E. A classification of unstable angina revisited. *Circulation* 2000;102:118–122.
2. Braunwald E, Antman EM, Beasley JW, et al. ACC/AHA guidelines for the management of patients with unstable angina and non-ST segment elevation myocardial infarction: a report of the American College of Cardiology/American Heart Association Task Force on Practice Guidelines (Committee on the Management of Patients with Unstable Angina). *J Am Coll Cardiol* 2000;36:970–1062.

3. Pope JH, Selker HP. Diagnosis of acute cardiac ischemia. *Emerg Med Clin North Am* 2003;21:27–59.
4. Selker HP, Zalenski RJ, Antman EM, et al. An evaluation of technologies for identifying acute cardiac ischemia in the emergency department: a report from a National Heart Attack Alert Program working group. *Ann Emerg Med* 1997;29:13–87.
5. Gerstenblith G. Derangements in cardiac metabolism in the ischemic state and consequences of reperfusion. *Adv Stud Med* 2004;4(6B):S464–S471.
6. Alpert JS, Thygesen K, Antman E, Bassand JP. Myocardial infarction redefined: a consensus document of the Joint European Society of Cardiology/American College of Cardiology Committee for the Redefinition of Myocardial Infarction. *J Am Coll Cardiol* 2000;36:959–969.
7. Jaffe AS. Testing the wrong hypothesis: the failure to recognize the limitations of troponin testing. *J Am Coll Cardiol* 2001;38:999–1001.
8. McDonough JL, Labugger R, Van Eyk JE. Prepare to meet your markers: making the most of troponin degradation. In: Adams JE, Apple FS, Jaffe AS, Wu AHB, eds. *Markers in Cardiology: Current and Future Clinical Applications*. Futura, Armonk, NJ, 2001, pp. 13–21.
9. Libby P, Ridker PM, Maseri A. Inflammation and atherosclerosis. *Circulation* 2002;105:1135–1143.
10. Liuzzo G, Biasucci LM, Rebuzzi AG, et al. Plasma protein acute-phase response in unstable angina is not induced by ischemic injury. *Circulation* 1996;94:2373–2380.
11. Morrow DA, Rifai N, Antman EM, et al. C-reactive protein is a potent predictor of mortality independently of and in combination with troponin T in acute coronary syndromes: a TIMI 11A substudy. *J Am Coll Cardiol* 1998;31:1460–1465.
12. Andre P, Nannizzi-Alaimo L, Prasad SK, Phillips DR. Platelet-derived CD40L: the switch-hitting player of cardiovascular disease. *Circulation* 2002;106:896–899.
13. Inwald DP, McDowell A, Peters MI, et al. CD40 is constitutively expressed on platelets and provides a novel mechanism for platelet activation. *Circ Res* 2003;92:1041–1048.
14. Heeschen C, Dimmler S, Hamm CW, et al. Soluble CD40 ligand in acute coronary syndromes. *N Engl J Med* 2003;348:1104–1111.
15. Varo N, de Lemos JA, Libby P, et al. Soluble CD40L risk prediction after acute coronary syndromes. *Circulation* 2003;108:1049–1052.
16. Baldus S, Heitzer T, Eiserich JP, et al. Myeloperoxidase enhances nitric oxide catabolism during myocardial ischemia and reperfusion. *Free Radic Biol Med* 2004;37:902–911.
17. Baldus S, Heeschen C, Meinertz T, et al., for the CAPTURE investigators. Myeloperoxidase serum levels predict risk in patients with acute coronary syndromes. *Circulation* 2003;108:1440–1445.
18. Brennan ML, Penn MS, Van Lente F, et al. Prognostic value of myeloperoxidase in patients with chest pain. *N Engl J Med* 2003;349:1595–1604.
19. Qin QP, Laitinen P, Majamaa-Voltti K, et al. Release patterns of pregnancy associated plasma protein A (PAPP-A) in patients with acute coronary syndromes. *Scand Cardiovasc J* 2002;36:358–361.
20. Cosin-Sales J, Christiansen M, Kaminski P, et al. Pregnancy-associated plasma protein A and its endogenous inhibitor, the proform of eosinophil major basic protein (proMBP) are related to complex stenosis morphology in patients with stable angina pectoris. *Circulation* 2004;109:1724–1728.
21. Lund J, Qin QP, Ilva T, et al. Circulating pregnancy-associated plasma protein A predicts outcome in patients with acute coronary syndrome but no troponin I elevation. *Circulation* 2003;108:1924–1926.
22. Laterza OF, Cameron SJ, Chappell D, Sokoll LJ, Green GB. Evaluation of pregnancy-associated plasma protein A as a prognostic indicator in acute coronary syndrome patients. *Clin Chim Acta* 2004;348:163–169.
23. Chiang TM. Activation of phospholipase D in human platelets by collagen and thrombin and its relationship to platelet aggregation. *Biochem Biophys Acta* 1994;1224:147–155.
24. Cox DA, Cohen ML. Relationship between phospholipase D activation and endothelial vasomotor dysfunction in rabbit aorta. *J Pharmacol Exp Ther* 1997;283:305–311.
25. Wevers RA, Engelke U, Heerschap A. High-resolution 1H-NMR spectroscopy of blood plasma for metabolic studies. *Clin Chem* 1994;40:1245–1250.
26. Danne O, Mockel M, Lueders C, et al. Prognostic implications of elevated whole blood choline levels in acute coronary syndromes. *Am J Cardiol* 2003;91:1060–1067.
27. Bar-Or D, Lau E, Rao N, Winkler J. A novel assay for the cobalt-albumin binding and its potential as a marker for myocardial ischemia: a preliminary report. *J Emerg Med* 2000;19:311–315.
28. Bar-Or D, Winkler J, VanBenthuyzen K, et al. Reduced cobalt binding of human albumin with ransient myocardial ischemia following elective percutaneous transluminal coronary angioplasty compared to CK-MB, myoglobin and troponin I. *Am Heart J* 2001;141:985–991.

29. Christenson RH, Duh SH, Sanhai WR, et al. Characteristics of an Albumin Cobalt Binding Test for assessment of acute coronary syndrome patients: a multicenter study. *Clin Chem* 2001;47:464–470.
30. Sinha MK, Gaze DC, Tippins JR, Collinson PO, Kaski JC. Ischemia modified albumin is a sensitive marker of myocardial ischemia after percutaneous coronary intervention. *Circulation* 2003;107:2403–2405.
31. Sinha MK, Roy D, Gaze DC, et al. Role of “ischemia modified albumin,” a new biochemical marker of myocardial ischemia, in the early diagnosis of acute coronary artery syndromes. *Emerg Med J* 2004;21:29–34.
32. Simic D, Mimic-Oka J, Pljesa M, et al. Time course of erythrocyte antioxidant activity in patients treated by thrombolysis for acute myocardial infarction. *Jpn Heart J* 2003;2003:823–832.
33. Blankenberg S, Rupprecht HJ, Bickel C, et al. Glutathione peroxidase 1 activity and cardiovascular events in patients with coronary artery disease. *N Engl J Med* 2003;349:1605–1613.
34. Kleinfeld AM, Prothro D, Brown DL, et al. Increases in serum unbound free fatty acid levels following coronary angioplasty. *Am J Cardiol* 1996;78:1350–1354.
35. Kleinfeld AM, Kleinfeld KJ, Adams JE. Serum levels of unbound free fatty acids reveal high sensitivity for early detection of acute myocardial infarction in patient samples from the TIMI II trial. *J Am Coll Cardiol* 2002;39(Suppl 2):413A.
36. Adams JE, Kleinfeld A, Roe M, et al. Measurement of levels of unbound free fatty acid allows the early identification of patients with acute coronary syndromes [abstract]. *Circulation* 2002;105:I-324.
37. Elgebaly SA, Kozol RA, Masetti P, Bohr M, Lennan C. Release of neutrophil chemotactic factors from ischemic myocardial tissues. *Surg Forum* 1987;38:276–279.
38. Elgebaly SA, Hashimi FH, et al. Cardiac-derived neutrophil chemotactic factors: detection in coronary sinus effluents of patients undergoing myocardial revascularization. *J Thorac Cardiovasc Surg* 1992;103:952–959.
39. Elgebaly SA, Mauri F, Azrin M, et al. Cardiac-derived neutrophil chemotactic factor: an early diagnostic marker for cardiac patients. 2004; manuscript in preparation.



# III

---

## BIOMARKERS OF INFLAMMATION

---





# 14

---

## Inflammation in Cardiovascular Disease

*The Biological Basis of Inflammatory Biomarkers*

---

*Peter Libby, MD*

### CONTENTS

INTRODUCTION

ATHEROSCLEROSIS: NO LONGER A BLAND LIPID-STORAGE DISEASE

INFLAMMATION IN PATHOGENESIS OF ACUTE CORONARY SYNDROMES

INFLAMMATORY PATHWAY IN ATHEROSCLEROSIS:

    BIOLOGICAL BASIS OF BIOMARKERS IN PREDICTION

    AND PROGNOSTICATION IN ATHEROSCLEROTIC DISEASE

WHAT EXPLAINS THE HIERARCHY OF UTILITY OF INFLAMMATORY  
BIOMARKERS?

CRP: MARKER OR MEDIATOR?

CRP: A NONSPECIFIC MARKER OF INFLAMMATION

CLINICAL UTILITY OF INFLAMMATORY BIOMARKERS

    IN CARDIOVASCULAR DISEASE

CONCLUSION

REFERENCES

---

### SUMMARY

A major shift has occurred in the understanding of the pathogenesis of atherosclerosis, myocardial dysfunction, and other important cardiovascular diseases. Traditional thinking conceived of atherosclerosis as a bland lipid storage disease. However, the current thinking regarding this and other cardiovascular disorders recognizes an important role for biological processes such as inflammation and its inextricably linked companion, oxidative stress, in their pathogenesis. This emerging story of inflammation as a unifying hypothesis for the pathogenesis of many cardiovascular diseases has swept through contemporary cardiology and now stands on the threshold of clinical fruition by the application of biomarkers. Currently converging clinical and experimental evidence has pointed to specific participants in atherothrombosis as potential novel biomarkers. Although currently there is a lack of sufficient evidence to support wide-scale changes in clinical practice based on the application of inflammatory biomarkers, the

From: *Contemporary Cardiology:  
Cardiovascular Biomarkers: Pathophysiology and Disease Management*  
Edited by: David A. Morrow © Humana Press Inc., Totowa, NJ

next several years should witness critical tests of the inflammatory hypothesis in the clinic that may prove useful in modifying the management of both individuals without manifest cardiovascular disease and those with established cardiovascular disorders. This rapid adoption of the concept of inflammation by practitioners furnishes an example of how fundamental laboratory research may change clinical practice and improve patient outcomes when translated to practice.

**Key Words:** Atherothrombosis; atherogenesis; inflammation; biomarkers.

## INTRODUCTION

The past few years have witnessed a major shift in the understanding of the pathogenesis of atherosclerosis, myocardial dysfunction, and other important cardiovascular diseases. For example, traditional thinking conceived of atherosclerosis as a bland lipid-storage disease. Until recently, the complications of atherosclerosis were viewed fundamentally as “plumbing” problems. Angina pectoris and acute myocardial infarction were thought to result from progressive stenoses in the coronary arteries caused by smooth muscle and extracellular matrix-rich obstructive lesions.

The traditional understanding of hypertension emphasized inappropriate vasoconstriction and disordered salt and water metabolism as key elements in the pathogenesis of this prevalent disorder. Likewise, until recently most viewed myocardial failure as a mechanical problem based on myocyte dysfunction. The classic view of diseases of the heart valves and cardiac skeleton (notably sclerocalcific aortic valve disease) and annular calcification considered them as inevitable “degenerative” processes associated with aging.

The current understanding of these various common cardiovascular maladies now encompasses an important role for biological processes such as inflammation and its inextricably linked companion, oxidative stress, in their pathogenesis. This synthesis that views involvement of inflammation provides a unifying hypothesis for the pathogenesis of many cardiovascular diseases has swept through contemporary cardiology and now stands on the threshold of clinical fruition by the application of biomarkers. This chapter reviews the biological basis of biomarkers rooted in inflammation. The understanding of the details of inflammation biology has progressed the most in the study of atherosclerosis. Therefore, this chapter illustrates the concept of the participation of inflammatory pathways in cardiovascular disease (CVD) by highlighting the current understanding of the contribution of inflammation to atherogenesis and its complications.

## ATHEROSCLEROSIS: NO LONGER A BLAND LIPID-STORAGE DISEASE

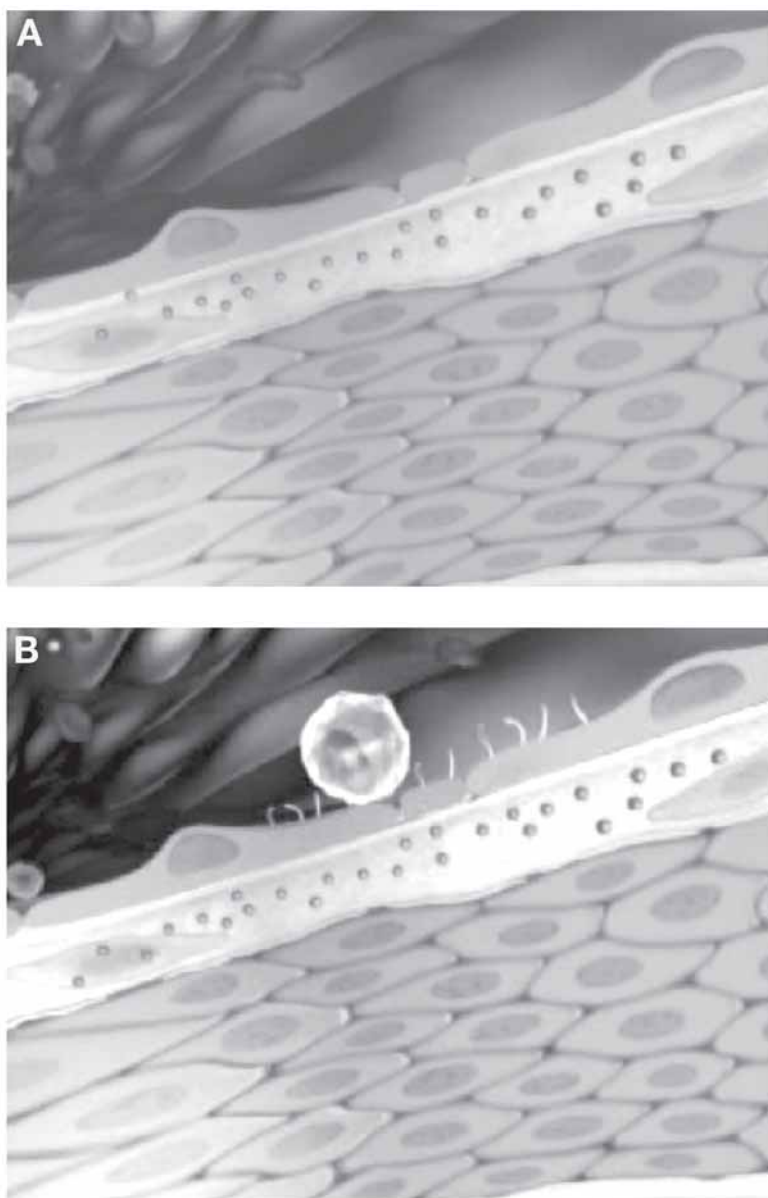
Only a few decades ago the prevailing postulate regarding the pathogenesis of atherosclerosis predicated a proliferation of smooth muscle cells (SMCs) leading to a fibrous stenotic lesion that surrounded a “necrotic core” of deposited cholesterol and cholesteryl esters (1). A combination of observations on experimental atherosclerosis and study of human atherosclerotic lesions has added to this traditional model of atherogenesis by encompassing inflammatory processes. Early after initiation of a diet enriched in cholesterol and saturated fat, sites in the arteries of experimental animals begin to recruit inflammatory leukocytes from the blood (2). The normal endothelial cell (EC) either *in situ* or in the laboratory resists adhesive interactions with leukocytes derived from blood. How-

ever, cultured ECs stimulated by proinflammatory cytokines express on their surface adhesion molecules that capture leukocytes and bind them to the endothelial surface. Soon after initiation of a hypercholesterolemic diet, the arteries of susceptible animal species display augmented expression of a variety of leukocyte adhesion molecules, including vascular cell adhesion molecule-1 (VCAM-1) and P-selectin. In rabbits that consume an atherogenic diet, expression of the adhesion molecule VCAM-1 precedes the accumulation of leukocytes in the intima (3). Atherosclerotic mice expressing a mutated form of VCAM-1 that inhibits its leukocyte-binding function show blunted atherosclerotic lesion formation (4). Interestingly, VCAM-1 binds just those types of white blood cells found in early atherosclerotic lesions in both experimental animals and humans, i.e., mononuclear phagocytes and T-lymphocytes. Thus, the transition of the normal artery to the nascent atherosclerotic lesion fundamentally depends on the recruitment of blood leukocytes to initiate and later perpetuate an inflammatory response.

Once bound to the endothelial surface, the leukocyte requires a chemoattractant signal to direct its migration into the subendothelial intimal layer, the site of the atherosclerotic lesion. Multiple proinflammatory cytokines probably participate in this process. First and foremost, monocyte chemoattractant protein-1 (MCP-1) promotes transmigration of mononuclear leukocytes. Intrinsic vascular wall cells, endothelium, and smooth muscle can produce MCP-1. Observations in experimental and human atherosclerotic lesions have documented overexpression of MCP-1 compared to normal arteries. Experiments in genetically altered mice have shown that loss of MCP-1 function, or that of its receptor chemokine receptor-2, can inhibit experimental atherogenesis (5,6). Other chemoattractant cytokines such as fractalkine and interleukin (IL)-8 may also direct the migration of adherent leukocytes during atherogenesis (7,8). In combination, these observations highlight the importance of chemoattractant cytokines as participants in the atherosclerotic process.

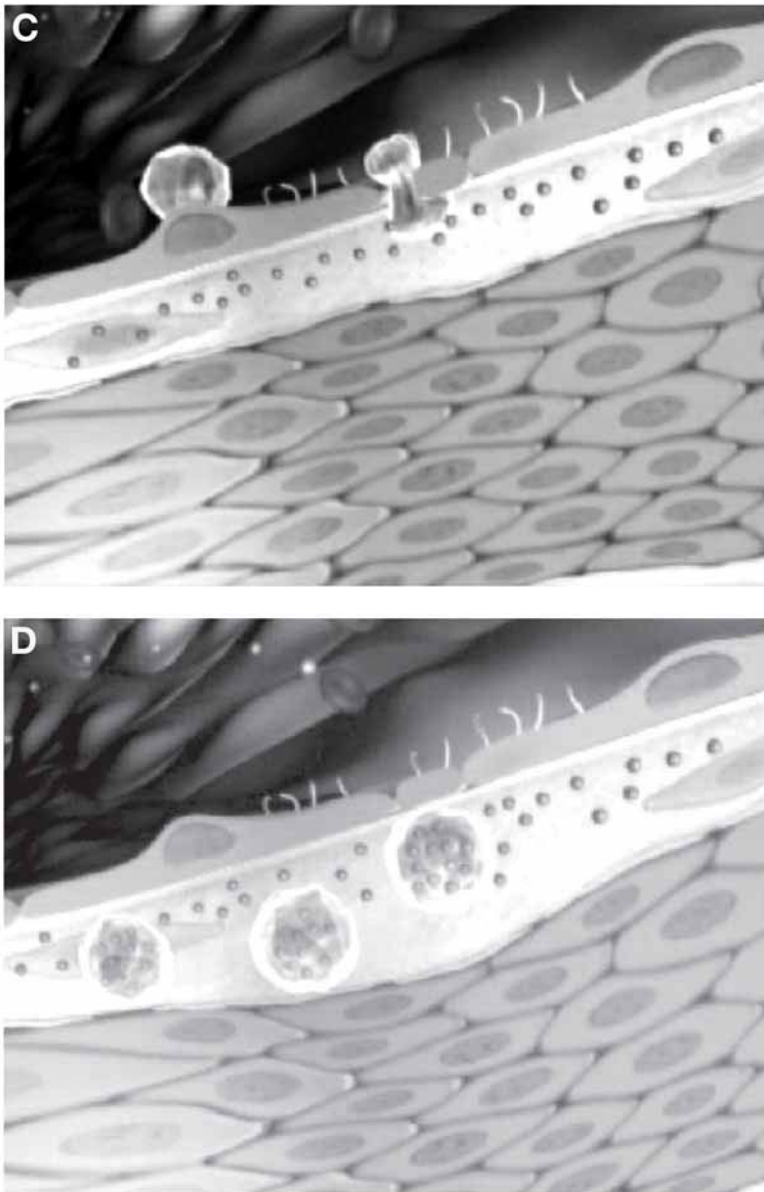
Once resident in the arterial intima, mononuclear phagocytes change their character and acquire the characteristics of foam cells. After penetrating into the intima, the blood monocyte expresses scavenger receptors, allowing it to take up modified lipoproteins that accumulate in the subendothelial space. The scavenger receptors evade the usual homeostatic suppression by excessive cholesterol characteristic of the classic low-density lipoprotein (LDL) receptor. This untrammelled ability to take up lipoproteins leads to the formation of lipid-laden macrophages known as foam cells, the hallmark of the early atherosclerotic lesion, also known as the fatty streak. Macrophages within the artery wall can also divide and elaborate reactive oxygen species and proinflammatory cytokines that can sustain and amplify intimal inflammation (9,10). Several proinflammatory mediators likely participate in signaling proliferation and activation of the macrophages present in the plaque. One prominent candidate, macrophage colony-stimulating factor (M-CSF), clearly plays a pathogenic role in experimental atherosclerosis. Animals that lack M-CSF show impaired lesion formation in response to atherogenic diets (11,12). This inhibition of atherogenesis occurs despite an increase in plasma cholesterol levels. Human and experimental atherosclerotic plaques overexpress M-CSF (13,14). In vitro, M-CSF can serve as a comitogen for macrophages and stimulate the expression of scavenger receptors by these inflammatory cells (13). Taken together, these observations provide strong evidence for the participation of inflammatory cells and mediators that attract and stimulate them in atherogenesis (Fig. 1A–D).

Fatty streaks alone do not threaten human health. Rather, clinical events arising from more complicated atherosclerotic lesions often evolve from fatty streaks. This transition



**Fig. 1.** (A) Normal human artery, including endothelial surface lining lumen, underlying intimal layer, and subjacent tunica media. (B) The endothelial cells exposed to inflammatory mediators express leukocyte adhesion molecules, indicated by the frondlike structures on their luminal surface. These adhesion molecules engage cognate receptors on blood leukocytes, tethering them and causing them to attach to the endothelial surface.

from fatty streak to fibro-fatty lesion involves the participation of SMCs. The normal human coronary arterial intima contains resident SMCs. The tunica media that underlies the intimal layer of arteries contains abundant SMCs. Inflammatory mediators can promote the migration of medial SMCs into the intima. Inflammatory mediators can also heighten the expression of growth factors such as platelet-derived growth factor (PDGF) and forms



**Fig. 1.** (C) Chemoattractant cytokines such as MCP-1, fractalkine, and IL-8 signal leukocytes to penetrate through the endothelial layer into the intima by diapedesis. (D) Once resident in the intima, blood monocytes express scavenger receptors, engulf lipoprotein particles, and become foam cells, the hallmark of the fatty streak, the precursor of complicated atherosclerotic lesions. Macrophages in the plaque can also replicate. Inflammatory mediators such as M-CSF can promote scavenger receptor production and proliferation of the lesional macrophages within atheromata.

of fibroblast growth factor that can augment SMC migration and proliferation. Interruption of inflammatory signaling pathways such as the CD40 ligand (CD40L)–CD40 dyad can limit the formation of fibrous plaques, a key component of the progression of atherosclerotic lesions. Indeed, interruption of CD40 signaling in animals with established atherosclerotic lesions can halt the progression of lesions (15,16). These observations sup-

port the participation of inflammatory signaling pathways in the progression phase of atherogenesis.

### INFLAMMATION IN PATHOGENESIS OF ACUTE CORONARY SYNDROMES

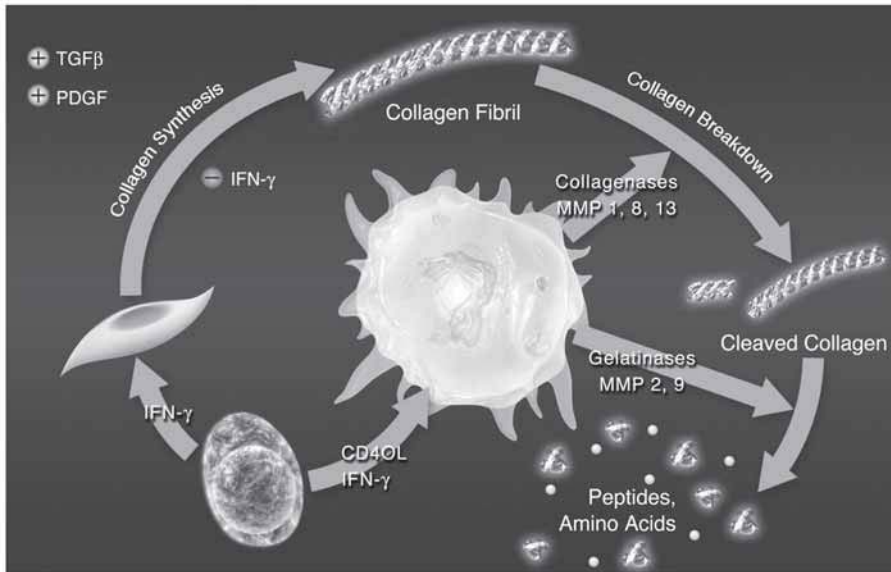
The understanding of the pathogenesis of the acute thrombotic complications of atherosclerosis has burgeoned in recent years. It is now understood that many acute thrombotic coronary occlusions do not necessarily result from critically stenosed sites in the arteries (17). Rather, lesions that do not cause critical stenosis often underlie thrombi that cause acute coronary syndromes (ACSs). This distinction between lesion vs lumen has challenged the traditional reliance on coronary anatomy as revealed by angiogram as the sole arbiter of the risk of ACS (18). Much of the thinking about ACS has shifted from a hydraulic viewpoint to a more nuanced biological perspective (19). As in the initiation and progression of atherosclerosis, ample data support the participation of inflammation in these thrombotic complications of atherosclerosis.

Pathological analysis of plaques that cause fatal coronary thrombosis supports this concept. Pathologists have taught researchers that physical disruption of atherosclerotic plaques most often provokes acute coronary thrombosis (20). Plaques that tend to cause fatal coronary thrombi share certain morphological characteristics. Notably, plaques that rupture and cause thrombosis tend to have large accumulations of inflammatory cells and a relative paucity of SMCs. Moreover, plaques that have ruptured and caused fatal thrombi typically have a thin protective fibrous cap that overlies the thrombogenic lipid core.

The fragility of the fibrous cap depends fundamentally on inflammation (Fig. 2) (19,21). Inflammatory mediators released from lesional lymphocytes, in particular interferon (IFN)- $\gamma$ , can impair the ability of SMCs to synthesize collagen fibrils, the mainstay of the biomechanical integrity of the plaque's fibrous cap. Inflammatory mediators can also heighten the production of enzymes that specialize in breaking down fibrillar collagen in the plaque's fibrous cap. Human atherosclerotic lesions overexpress all three known human interstitial collagenases, members of the matrix metalloproteinase (MMP) family (22). Inflammatory stimuli augment the production of the interstitial collagenases MMP-1, MMP-13, and MMP-8 from several cell types found in atherosclerotic plaques. Human atherosclerotic plaques also contain elevated levels of active forms of MMP-9, an enzyme with gelatinolytic activity that can continue the catabolism of collagen cleaved by the interstitial collagenases (23). Inflammatory mediators regulate this enzyme, which can also degrade elastin (24,25). These data indicate a pivotal role for inflammation in regulating the level of collagen in the plaque's fibrous cap, a key determinant of its ability to resist rupture (26). Thus, inflammatory processes critically regulate the fragility of the plaque's fibrous cap (Fig. 3).

Inflammation signaling also controls the thrombogenicity of the content of atheromata. The proximal trigger to coronary thrombosis, tissue factor, also depends on inflammatory signaling. The inflammatory mediator CD40L plays a particularly important role in augmenting tissue factor expression by lesional M $\Phi$ , the major source of this potent procoagulant in human atherosclerotic plaques (27).

Inflammatory mediators such as IL-1 can also promote the production of plasminogen activator inhibitor-1 (PAI-1), a potent blocker of endogenous fibrinolytic pathways that protect against thrombus accumulation. Therefore, inflammation not only enhances thrombogenicity of the plaque but also can limit fibrinolysis, two parallel processes that conspire to augment accumulation of thrombi and, hence, precipitate ACS (28). Thus, from plaque



**Fig. 2.** Inflammation regulates the metabolism of fibrillar collagen, the major barrier to atherosclerotic plaque disruption. Proinflammatory cytokines such as IFN- $\gamma$  released from the T-lymphocyte (lower left) inhibit the ability of SMCs to synthesize new collagen required to repair and maintain the collagenous matrix of the plaque's fibrous cap, which protects the plaque from rupture. Another T-cell-derived cytokine, CD40L, stimulates mononuclear phagocytes (center) to elaborate interstitial collagenases, including MMP-1, MMP-8, and MMP-13, that catalyze the initial proteolytic cleavage of the intact collagen fibril. The cleaved collagen becomes susceptible to further degradation by gelatinases such as MMP-9. In this way, inflammation can threaten the stability of atherosclerotic plaques; increase their propensity to rupture; and, hence, cause thromboses that underlie most ACSs. TGF $\beta$ , transforming growth factor  $\beta$ .



**Fig. 3.** Inflammation affects all phases of atherosclerosis. Recruitment of inflammatory cells from peripheral blood initiates the atherosclerotic changes in the arterial intima that set the stage for atherogenesis (upper left). The generally prolonged and silent or clinically stable stage of lesion evolution involves migration and proliferation of SMCs. Abundant experimental data support a role for inflammation in this intermediary phase of atherogenesis (middle). Arterial thrombosis, often owing to plaque rupture, also depends on inflammatory signaling (lower right; *see also* Fig. 2). (Reproduced from ref. 29, with permission.)



initiation through the long, generally silent, or clinically stable phase of lesion progression and, finally, the culmination of the ultimate clinical complications of atherosclerosis, inflammatory signaling participates prominently in this disease (29).

### INFLAMMATORY PATHWAY IN ATHEROSCLEROSIS: BIOLOGICAL BASIS OF BIOMARKERS IN PREDICTION AND PROGNOSTICATION IN ATHEROSCLEROTIC DISEASE

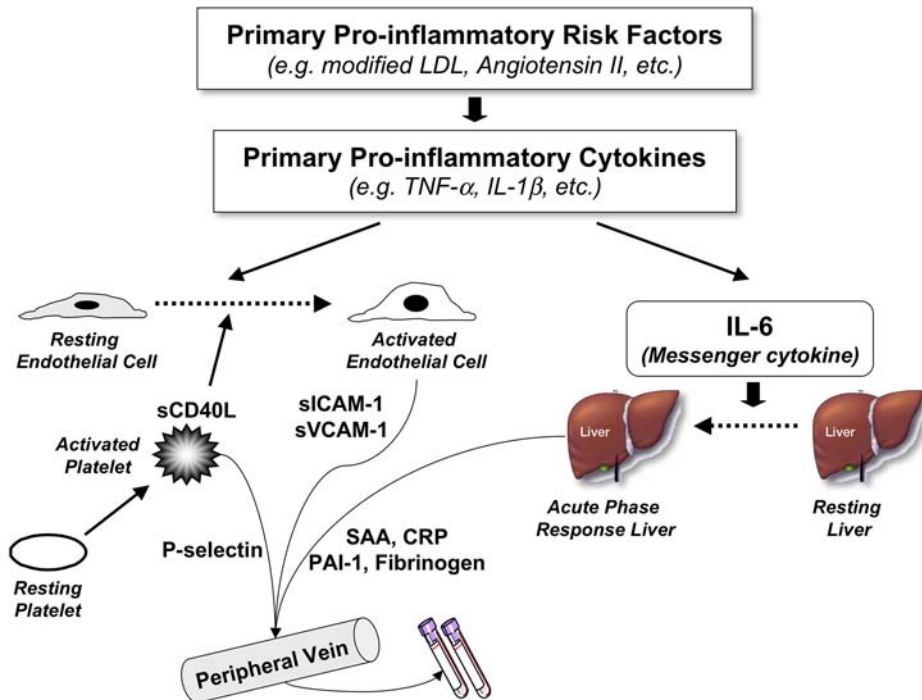
Recognition of the role of inflammation as a master regulator of atherogenesis has provided a fresh intellectual construct for understanding this disease. This new scientific foundation for understanding atherogenesis also furnishes insights into novel therapeutic targets that may assist its mitigation. While inflammation biology currently furnishes new insights into the mechanism of benefit of existing therapeutics, the promise of targeted anti-inflammatory interventions to prevent or treat atherosclerosis will require much greater time and effort. Yet, one type of practical application of inflammation biology promises favorable outcome in terms of more prompt clinical applicability. Biomarkers of inflammation may soon merit inclusion in clinical application, the topic of many contributions to this volume.

As data concerning the utility of biomarkers of inflammation in prospective cardiovascular risk prediction emerged, they appeared to fit into a pattern. One theoretical construct may help to systematize the biological basis of biomarkers of inflammation in the cardiovascular arena (Fig. 4) (30). According to this hypothesis, a first wave of primary proinflammatory cytokines could arise from either vascular or extravascular sources (Fig. 4, top). Examples of primary proinflammatory cytokines include the soluble mediators IL-1 $\beta$  and tumor necrosis factor (TNF)- $\alpha$ . Intravascular sources could include the atheroma itself, a hotbed of inflammatory signaling, as already discussed. Extravascular sources could include foci of chronic infection, such as prostatitis, bronchitis, periodontal disease, or stasis or ischemic ulcers. Unfortunately, another potential source of extravascular inflammatory stimuli, visceral adipose tissue, will become more prominent owing to the currently increasing prevalence of obesity.

The inflammatory stimuli produced by primary proinflammatory cytokines may undergo amplification through the induction of IL-6 production. Multiple cell types including vascular SMCs and ECs can produce large amounts of IL-6 when exposed to IL-1 $\beta$  or TNF- $\alpha$  (31–34). This amplification magnifies the inflammatory output owing to the initial proinflammatory cytokine signals.

IL-6, a soluble mediator, controls the hepatic acute-phase response. This coordinated change in the program of liver protein synthesis typifies the organism's response to injury or inflammation. When exposed to IL-6, hepatocytes augment their expression of proteins of the acute-phase response, including fibrinogen; PAI-1; serum amyloid A (SAA); and, notably, C-reactive protein (CRP) (see Chapters 16 and 17). The primary proinflammatory cytokines can also impinge on vascular endothelial and other cells to augment their expression of leukocyte adhesion molecules, as mentioned previously. Many cell-surface molecules including certain leukocyte adhesion molecules can undergo proteolytic cleavage and enter the circulation in a shed form (Fig. 4, middle). Both acute-phase reactants from the liver and shed adhesion molecules enter peripheral blood accessible to sampling by routine venipuncture (Fig. 4, bottom) (see Chapter 18).

The scheme depicted in Fig. 4 provides a framework for understanding the biological basis of biomarkers of inflammation in cardiovascular and other diseases. Of course,



**Fig. 4.** A proposed inflammatory pathway that operates during atherosclerosis can augment inflammatory biomarker concentrations in peripheral blood. See text for explanation. sCD40L, soluble CD40L; IL, interleukin; TNF, tumor necrosis factor; sVCAM, soluble vascular adhesion molecule; PAI, plasminogen activator inhibitor; SAA, serum amyloid A; ICAM-1, intercellular adhesion molecule-1.

evidence is lacking for the sequence of events as depicted and described. Nevertheless, this model provides a useful working hypothesis to provide some order in the burgeoning roster of biomarkers described on an ongoing basis in contemporary literature. Clearly other contributors to peripherally sampled biomarkers exist. Notably, activated platelets can shed CD40L (*see* Chapter 18) and likely furnish the bulk of this inflammatory biomarker in circumstances such as ACS (35). Additionally, sources of acute-phase reactants other than the liver may contribute to their appearance in peripheral blood. In particular, evidence has appeared for CRP production locally within atherosclerotic lesions. However, given the size of the liver compared to the mass of atherosclerotic plaques, on a quantitative basis, the liver likely contributes the greatest share of CRP and other acute-phase reactants sampled in venous blood. The strategic location of visceral adipose tissue, draining into the portal circulation and perfusing the liver, provides another basis for hypothesizing a principal role for hepatocytes as a source of acute-phase reactants.

Because it incorporates the notion of an amplification loop, the model presented in Fig. 4 also helps researchers understand the utility of inflammatory biomarkers. Just a few molecules of a primary proinflammatory cytokine can beget the production of many more molecules of IL-6, the major mediator of the acute-phase response. This amplification loop helps in the understanding of how relatively small volumes of inflamed atherosclerotic plaques may nonetheless generate substantial signal measurable in peripheral blood, even in apparently healthy individuals.

## WHAT EXPLAINS THE HIERARCHY OF UTILITY OF INFLAMMATORY BIOMARKERS?

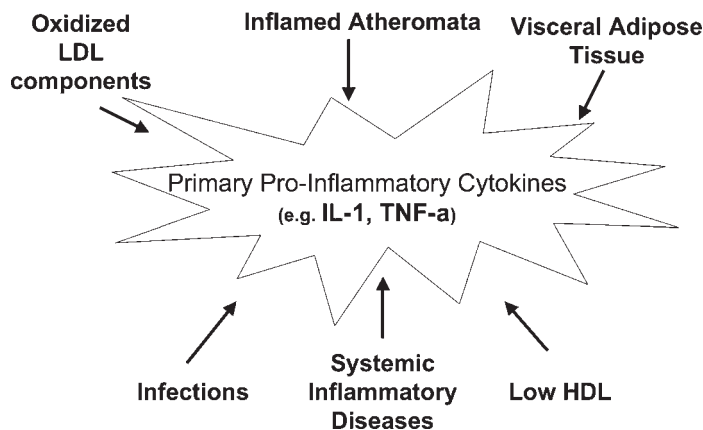
Among the growing menu of inflammatory biomarkers described in the literature, CRP has received the most focus and appears to furnish the most consistent relationship to clinical end points. Why should CRP, a distal indicator of inflammation, appear so potent as a risk predictor? The answer depends on a combination of fundamental and serendipitous features. Indeed, the acute-phase proteins PAI-1 and fibrinogen play direct roles in thrombus accumulation and might logically link more tightly to cardiovascular outcomes than CRP. In addition, the model put forth in Fig. 4 posits a principal role for IL-6 as an amplifier of the acute-phase response. Because IL-6 appears proximal to CRP in our schema, shouldn't its levels predict cardiovascular events with greater fidelity than the downstream marker CRP? CRP has proven to be a much more robust analyte than fibrinogen or PAI-1 (*see also* Chapter 26). Fibrinogen has diurnal fluctuations that render random samples less reliable. Because platelets contain PAI, avoiding spurious fluctuations requires considerable precaution to avoid platelet activation during blood drawing. IL-6 has a relatively short half-life. Unlike CRP, IL-6 and fibrinogen lack international standards and robust, reproducible assays. These considerations explain some of the apparent superiority of CRP as a biomarker of inflammation over other contributors through the pathway depicted in Fig. 4.

### CRP: MARKER OR MEDIATOR?

While many agree that CRP levels provide a prognostic indicator, the role of CRP as a potential proinflammatory mediator remains controversial. Multiple studies report proinflammatory properties of purified CRP. For example, exposure to CRP can augment cytokine and adhesion molecule expression from vascular ECs. CRP may mitigate the ability of ECs to elaborate nitric oxide, the endogenous antithrombotic and vasodilatory molecule. However, such experiments often employ CRP produced by recombinant DNA technology from bacterial sources. Small residual amounts of bacterial products such as lipopolysaccharide endotoxin might contribute to some of the effects of high concentrations of CRP observed *in vitro*. Experiments in transgenic mice that overexpress human CRP do support a prothrombotic role for CRP *in vivo* (36). Mice normally express little or no CRP. Finally, preliminary observations of CRP infusion in healthy human volunteers support a prothrombotic and an antifibrinolytic effect (37). Recombinant CRP infusion in human volunteers increases PAI-1 and IL-6. Compared to circulating or local levels of the cytokines that may ultimately lead to its increased expression in pathological circumstances, the relative importance of CRP as an indicator of inflammation remains uncertain. Moreover, the relevance of levels of CRP used for many *in vitro* experiments and fluctuations within the lower ranges of CRP that accurately predict increased cardiovascular risk require careful consideration.

### CRP: A NONSPECIFIC MARKER OF INFLAMMATION

CRP rises in many inflammatory conditions, ranging from acute infections to chronic inflammatory diseases such as rheumatoid arthritis. This nonspecificity of CRP elevations could understandably engender skepticism regarding its utility as a risk marker for cardiovascular diseases. The very nonspecificity of CRP elevation, however, may explain why it appears useful for cardiovascular risk prediction. CRP serves as an overall barometer or



**Fig. 5.** Multiple triggers can incite inflammation in CVDs. The first wave of proinflammatory cytokines hypothesized in Fig. 4 may arise from a variety of vascular and extravascular stimuli. See text for explanation. HDL, high-density lipoprotein.

integrator of inflammation in a given individual regardless of the source of that inflammation. The mix of proinflammatory stimuli that trigger the first wave of proinflammatory cytokines that ultimately elevate CRP levels likely differs among individuals. In some, chronic low-level infectious processes such as bronchitis or gingivitis may contribute to CRP elevation. In others, visceral adipose tissue may prevail as a stimulus for increased CRP levels. In others with widespread atherosclerotic plaques teeming with inflammatory activity, the atherosclerotic lesions themselves may contribute more to elevations in blood CRP levels. Since each of these diverse sources of initial inflammatory stimuli may augment atherogenesis or increase the risk of its thrombotic complications, CRP presents a simple gauge of inflammatory burden, whatever the mix of proximal stimuli that elicit the inflammatory response (Fig. 5).

## CLINICAL UTILITY OF INFLAMMATORY BIOMARKERS IN CARDIOVASCULAR DISEASE

### *What Is Known and What Must Still Be Learned?*

The promise of clinical translation of inflammation biology depends on the availability of a practical test such as CRP measured by the high sensitivity assay (hsCRP). It also requires a substantial evidence base to merit incorporation into daily practice and practice guidelines. Many, though hardly all, agree that sufficient evidence supports the ability of hsCRP to predict prospectively cardiovascular risk in primary prevention to encourage its consideration for clinical use. However, inclusion of CRP and other biomarkers of inflammation into clinically useful risk algorithms requires critical consideration. First, any biomarker, inflammatory or other, must demonstrate that it improves risk prediction beyond well-established and traditional risk factors such as those incorporated in the Framingham Risk Prediction Instrument. Chapter 16 contains full consideration of this point. In addition, a candidate biomarker must have a reproducible, available, and economical assay. The hsCRP assay fulfills such criteria. Optimally, adoption of a new risk marker should lead to cost-effective changes in therapy or management. Biomarkers of inflammation including hsCRP do not yet satisfy this criterion. The issue of the clinical

utility of inflammatory biomarkers in secondary prevention, notably after ACS, is discussed fully in Chapters 17 and 18.

Beyond risk stratification, could inflammatory biomarkers add to the management of CVD by serving as targets or guides for therapy? Until recently, little evidence supported such utility. As one follows levels of LDL or blood pressure, serial measurement of CRP has little basis in evidence despite its plausibility. The recent analysis of PROVE IT (Pravastatin or Atorvastatin Evaluation and Infection Therapy)-TIMI 22 begins to provide justification for CRP as a target of therapy (38). This study demonstrated better outcomes in survivors of ACS with not only below median LDL levels with statin treatment but also below median levels of hsCRP. Both variables were measured 1 mo after an ACS, obviating any artifactual changes owing to the acute-phase response. Although this prospective analysis of a large clinical trial indicates a role for CRP as a new target for statin therapy, other studies will be required to extend this concept to other interventions. Further confirmatory studies could hasten incorporation of the concept of CRP as a target of therapy into practice, critical pathways, and guidelines.

### ***Could Levels of Circulating Biomarkers of Inflammation Help Guide Therapy?***

A retrospective analysis of CRP levels in a large primary prevention trial, Air Force Coronary Atherosclerosis Project/Texas Coronary Atherosclerosis Project, suggested that apparently healthy individuals with below median LDL levels but above median hsCRP levels derived benefit from statin therapy (39). Curiously, individuals with both below median LDL and below median hsCRP levels did not benefit from treatment, indicating that promiscuous use of statins in primary prevention likely would not prove cost-effective and would expose one-fourth of the apparently healthy population to potential risks and expensive drug treatment without benefit.

This provocative *post hoc* analysis generated the intriguing hypothesis that one might identify apparently healthy individuals with below average LDL levels who nonetheless could benefit from statin therapy by assessing their inflammatory status, e.g., by measuring hsCRP. Despite its appeal, we currently lack prospective clinical trial evidence to support this change in practice. A large-scale, randomized clinical trial currently under way will test this hypothesis rigorously (40–42), and the results should shed light on the utility of inflammatory biomarkers as a guide for therapy in apparently healthy populations.

Some have proposed that assessment of inflammatory status might not only aid risk stratification but also provide a motivational tool for patients to change their modifiable risk factors such as smoking, diet, and physical activity. Although this concept has theoretical merit and acknowledges the vital importance of lifestyle in the modulation of cardiovascular risk, currently there is lack evidence that informing individuals of their inflammatory status will lead to sustained changes in behavior or modifiable risk factors. Indeed, in a military population, information regarding coronary calcium scores, a readily understandable putative risk marker, failed to yield behavioral change.

### ***Inflammatory Biomarkers and Clinical Utility***

Some have argued that assessment of inflammatory biomarkers is superfluous because of the lack of evidence-based interventions that would be predicated on them. Moreover, some oppose the measurement of inflammatory biomarkers on the grounds that if they revealed higher risk in patients already receiving maximal medical therapy, those results

would not change management. A more optimistic position would argue that residual risk indicated by inflammatory biomarkers in an optimally managed patient could provide impetus for intensification of lifestyle measures to ameliorate the individual's inflammatory profile. Weight loss, dietary interventions, smoking cessation, and regular physical activity may all mitigate inflammation beyond pharmacotherapy. Statins have received the greatest attention as pharmacological modifiers of inflammatory biomarkers. However, increasing evidence supports the possibility that other classes of medications may likewise modulate inflammation. Although aspirin has not consistently reduced levels of CRP, emerging evidence suggests that fibric acid derivatives, thiazolidinediones, and metformin can reduce such levels. The fibric acid derivatives can limit inflammation by activating peroxisome proliferator activated receptor- $\alpha$  (PPAR- $\alpha$ ). The thiazolidinediones (e.g., the glitazone class of insulin sensitizers) activate PPAR- $\gamma$  and may exert an anti-inflammatory action by this mechanism. Thus, residual inflammatory risk indicated by biomarkers such as CRP might be approached by intensified lifestyle modification and additional pharmacological measures beyond statins, even in patients who follow aggressive statin therapy.

## CONCLUSION

Only a few years ago, the concept that inflammation might contribute to CVD lacked currency among cardiovascular practitioners. Currently converging clinical and experimental evidence point to inflammation as a major participant in the pathogenesis of a variety of CVDs. Indeed, the inflammatory hypothesis provides a unifying concept that aids the understanding of disparate risk factors that converge on inflammatory pathways. This shift in the understanding of the pathogenesis of atherosclerosis and certain other CVDs now extends beyond understanding pathophysiology to the interface with clinical utility. This chapter has attempted to provide a foundation for understanding the biological basis of biomarkers of inflammation. Researchers currently lack sufficient evidence to support wide-scale changes in clinical practice based on application of inflammatory biomarkers. However, the next several years should witness critical tests of the inflammatory hypothesis in the clinic that may prove useful in modifying the management of both individuals without manifest CVD and those with established cardiovascular disorders. This rapid adoption of the concept of inflammation by practitioners furnishes an example of how fundamental laboratory research may change clinical practice and improve patient outcomes when translated to practice.

## ACKNOWLEDGMENTS

We thank David Lynn and Karen Williams for their editorial contributions. This work was supported by grants from the National Heart, Lung, and Blood Institute; the Donald W. Reynolds Foundation; and Fondation Leducq.

## REFERENCES

1. Ross R. Atherosclerosis: the role of endothelial injury, smooth muscle proliferation and platelet factors. *Triangle* 1976;15:45–51.
2. Libby P. Inflammation in atherosclerosis. *Nature* 2002;420:868–874.
3. Li H, Cybulsky MI, Gimbrone MA Jr, Libby P. An atherogenic diet rapidly induces VCAM-1, a cytokine regulatable mononuclear leukocyte adhesion molecule, in rabbit endothelium. *Arterioscler Thromb* 1993;13:197–204.

4. Cybulsky MI, Iiyama K, Li H, et al. A major role for VCAM-1, but not ICAM-1, in early atherosclerosis. *J Clin Invest* 2001;107:1255–1262.
5. Gu L, Okada Y, Clinton S, et al. Absence of monocyte chemoattractant protein-1 reduces atherosclerosis in low-density lipoprotein-deficient mice. *Mol Cell* 1998;2:275–281.
6. Boring L, Gosling J, Cleary M, Charo IF. Decreased lesion formation in CCR2<sup>-/-</sup> mice reveals a role for chemokines in the initiation of atherosclerosis. *Nature* 1998;394:894–897.
7. Lesnik P, Haskell CA, Charo IF. Decreased atherosclerosis in CX3CR1<sup>-/-</sup> mice reveals a role for fractal-kine in atherogenesis. *J Clin Invest* 2003;111:333–340.
8. Boisvert WA, Curtiss LK, Terkeltaub RA. Interleukin-8 and its receptor CXCR2 in atherosclerosis. *Immunol Res* 2000;21:129–137.
9. Rosenfeld ME, Ross R. Macrophage and smooth muscle cell proliferation in atherosclerotic lesions of WHHL and comparably hypercholesterolemic fat-fed rabbits. *Arteriosclerosis* 1990;10:680–687.
10. Gordon D, Reidy MA, Benditt EP, Schwartz SM. Cell proliferation in human coronary arteries. *Proc Natl Acad Sci USA* 1990;87:4600–4604.
11. Smith JD, Trogan E, Ginsberg M, Grigaux C, Tian J, Miyata M. Decreased atherosclerosis in mice deficient in both macrophage colony-stimulating factor (op) and apolipoprotein E. *Proc Natl Acad Sci USA* 1995;92:8264–8268.
12. Qiao JH, Tripathi J, Mishra NK, et al. Role of macrophage colony-stimulating factor in atherosclerosis: studies of osteopetrotic mice. *Am J Pathol* 1997;150:1687–1699.
13. Clinton S, Underwood R, Sherman M, Kufe D, Libby P. Macrophage-colony stimulating factor gene expression in vascular cells and in experimental and human atherosclerosis. *Am J Pathol* 1992;140:301–316.
14. Rosenfeld M, Ylä-Herttuala S, Lipton B, Ord V, Witztum J, Steinberg D. Macrophage colony-stimulating factor mRNA and protein in atherosclerotic lesions of rabbits and humans. *Am J Pathol* 1992;140:291–300.
15. Schonbeck U, Sukhova GK, Shimizu K, Mach F, Libby P. Inhibition of CD40 signaling limits evolution of established atherosclerosis in mice. *Proc Natl Acad Sci USA* 2000;97:7458–7463.
16. Lutgens E, Cleutjens KB, Heeneman S, Kotliansky VE, Burkly LC, Daemen MJ. Both early and delayed anti-CD40L antibody treatment induces a stable plaque phenotype. *Proc Natl Acad Sci USA* 2000;97:7464–7469.
17. Falk E, Shah P, Fuster V. Coronary plaque disruption. *Circulation* 1995;92:657–671.
18. Libby P. Lesion versus lumen. *Nat Med* 1995;1:17, 18.
19. Libby P, Theroux P. Pathophysiology of coronary artery disease. *Circulation* 2005;111:3481–3488.
20. Virmani R, Burke AP, Farb A, Kolodgie FD. Pathology of the unstable plaque. *Prog Cardiovasc Dis* 2002;44:349–356.
21. Libby P. Current concepts of the pathogenesis of the acute coronary syndromes. *Circulation* 2001;104:365–372.
22. Dollery CM, Libby P. Matrix metalloproteinases: atherosclerosis and protease activation. *Cardiovasc Res* 2005, in press.
23. Galis Z, Sukhova G, Lark M, Libby P. Increased expression of matrix metalloproteinases and matrix degrading activity in vulnerable regions of human atherosclerotic plaques. *J Clin Invest* 1994;94:2493–2503.
24. Galis Z, Muszynski M, Sukhova G, et al. Cytokine-stimulated human vascular smooth muscle cells synthesize a complement of enzymes required for extracellular matrix digestion. *Circ Res* 1994;75:181–189.
25. Saren P, Welgus HG, Kovanen PT. TNF-alpha and IL-1beta selectively induce expression of 92-kDa gelatinase by human macrophages. *J Immunol* 1996;157:4159–4165.
26. Fukumoto Y, Deguchi JO, Libby P, et al. Genetically determined resistance to collagenase action augments interstitial collagen accumulation in atherosclerotic plaques. *Circulation* 2004;110:1953–1959.
27. Mach F, Schoenbeck U, Bonnefoy J-Y, Pober J, Libby P. Activation of monocyte/macrophage functions related to acute atheroma complication by ligation of CD40: induction of collagenase, stromelysin, and tissue factor. *Circulation* 1997;96:396–399.
28. Vaughan DE. Plasminogen activator inhibitor-1 and the calculus of mortality after myocardial infarction. *Circulation* 2003;108:376, 377.
29. Libby P, Ridker PM, Maseri A. Inflammation and atherosclerosis. *Circulation* 2002;105:1135–1143.
30. Libby P, Ridker PM. Novel inflammatory markers of coronary risk: theory versus practice. *Circulation* 1999;100:1148–1150.
31. Sironi M, Breviario F, Proserpio P, et al. IL1 stimulates IL6 production in endothelial cells. *J Immunol* 1989;142:549–553.

32. Loppnow H, Libby P. Adult human vascular endothelial cells express the IL6 gene differentially in response to LPS or IL1. *Cell. Immunology* 1989;122:493–503.
33. Loppnow H, Libby P. Comparative analysis of cytokine induction in human vascular endothelial and smooth muscle cells. *Lymphokine Res* 1989;8:293–299.
34. Loppnow H, Libby P. Proliferating or interleukin 1-activated human vascular smooth muscle cells secrete copious interleukin-6. *J Clin Invest* 1990;85:731–738.
35. Henn V, Slupsky JR, Grafe M, et al. CD40 ligand on activated platelets triggers an inflammatory reaction of endothelial cells. *Nature* 1998;391:591–594.
36. Danenberg HD, Szalai AJ, Swaminathan RV, et al. Increased thrombosis after arterial injury in human C-reactive protein-transgenic mice. *Circulation* 2003;108:512–515.
37. Bisoendial R, Kastelein J, Levels J, et al. Activation of inflammation and coagulation after infusion of C-reactive protein in humans. *Circ Res* 2005;96:714–716.
38. Ridker PM, Cannon CP, Morrow D, et al. C-reactive protein levels and outcomes after statin therapy. *N Engl J Med* 2005;352:20–28.
39. Ridker PM, Rifai N, Clearfield M, et al. Measurement of C-reactive protein for the targeting of statin therapy in the primary prevention of acute coronary events. *N Engl J Med* 2001;344:1959–1965.
40. Ridker PM. Should statin therapy be considered for patients with elevated C-reactive protein?: the need for a definitive clinical trial. *Eur Heart J* 2001;22:2135–2137.
41. Ridker PM. Rosuvastatin in the primary prevention of cardiovascular disease among patients with low levels of low-density lipoprotein cholesterol and elevated high-sensitivity C-reactive protein: rationale and design of the JUPITER trial. *Circulation* 2003;108:2292–2297.
42. Ridker PM. High-sensitivity C-reactive protein, inflammation, and cardiovascular risk: from concept to clinical practice to clinical benefit. *Am Heart J* 2004;148(Suppl 1):S19–S26.





# 15

---

## Analytic Issues for Clinical Use of C-Reactive Protein

---

*Nader Rifai, PhD*

### CONTENTS

INTRODUCTION

WHAT INFLAMMATORY MARKER SHOULD BE MEASURED?

ANALYTIC ISSUES

SOURCES OF VARIABILITY IN CRP TESTING

INTERPRETATION OF CRP RESULTS

CONCLUSION

REFERENCES

---

### SUMMARY

The serum concentration of C-reactive protein (CRP) has historically been used to detect active infection and inflammation. Recent evidence has demonstrated that slight increases in CRP concentration, within the normal range, can predict future vascular events, thus reflecting the inflammatory component of atherosclerosis. It was necessary to develop new high-sensitivity methods for this clinical application, and to establish cut points for risk assessment of cardiovascular risk. To avoid misclassification of individuals into inappropriate categories of risk, clinicians and investigators must have an understanding of preanalytic and analytic sources of errors in CRP measurement. This chapter addresses issues that contribute to the reliability of CRP evaluation such as physiological variability, appropriate sample handling, and method standardizations.

**Key Words:** C-reactive protein; measurement; standardization; interpretation.

### INTRODUCTION

Atherogenesis is a process that starts early in life and progresses slowly and silently for decades with a clinical manifestation usually in the fifth decade of life for men and in the sixth for women. Risk factors such as hypertension, cigarette smoking, hypercholesterolemia, age, and gender have been used to assess the risk of developing coronary heart disease (CHD). It is now well accepted that chronic inflammation plays an important role in the inception and development of atherothrombotic disease. Biochemical markers of

From: *Contemporary Cardiology:  
Cardiovascular Biomarkers: Pathophysiology and Disease Management*  
Edited by: David A. Morrow © Humana Press Inc., Totowa, NJ

inflammation have been shown to be useful not only as prognostic tools in patients with acute coronary syndromes but also in predicting future risk of CHD in apparently healthy men and women. Primary inflammatory mediators such as cytokines and adhesion molecules and downstream indicators such as acute-phase reactants have emerged as potential diagnostic and prognostic indicators. This chapter examines the laboratory issues related to the measurement of these markers and the practical clinical issues for its evaluation.

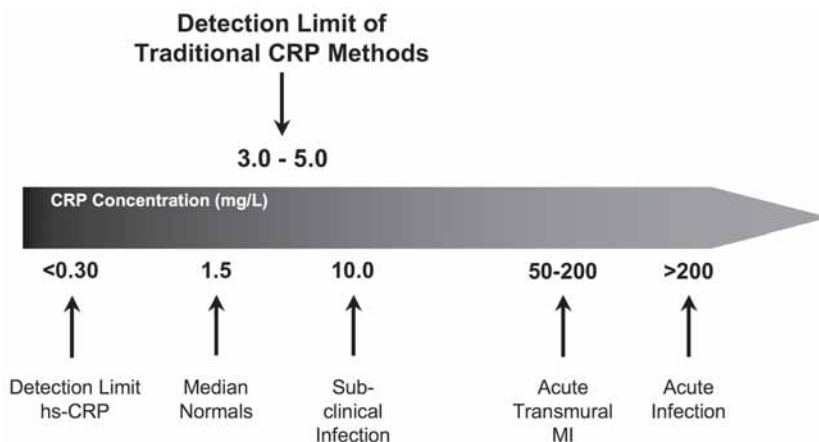
## WHAT INFLAMMATORY MARKER SHOULD BE MEASURED? ANALYTIC ISSUES

### *Cytokines and Adhesion Molecules*

Prospective clinical trials have demonstrated that cytokines such as interleukin (IL)-1 $\beta$ , IL-6, IL-8, IL-10, and IL-18; tumor necrosis factor (TNF)- $\alpha$ ; CD40 ligand; and adhesion molecules such as E and P selectin, intercellular adhesion molecule-1, and vascular cell adhesion molecule-1 are associated with CHD (1–4). However, the laboratory measurement of these markers is problematic. These markers are present in the circulation at very low concentrations and are typically measured by enzyme-linked immunosorbent assay techniques. Although some improvements in these techniques have taken place, the assays are still cumbersome, labor intensive, difficult to automate, not standardized, lacking the desired level of sensitivity, not approved by the Food and Drug Administration (FDA) for clinical use, and not available in routine clinical laboratories. In addition, most of these analytes are very unstable after collection. Therefore, blood specimens should be tested immediately after they are obtained or else the samples should be kept frozen at  $-70^{\circ}\text{C}$  until analysis. For these reasons, the measurement of cytokines and adhesion molecules is done only in the research laboratory and has not made the transition into routine clinical practice.

### *Acute-Phase Proteins*

The associations of fibrinogen, serum amyloid A (SAA), and C-reactive protein (CRP) with CHD have been clearly established (4–6). Clinical assays for these three proteins are currently available. Fibrinogen is measured in clinical laboratories using more than 40 different methods employing functional assays. Although these methods are relatively precise ( $\sim 10\%$  reproducibility), they are not standardized. Therefore, significant variability in the measured fibrinogen in a particular sample is seen among laboratories. For example, according to the College of American Pathologists, fibrinogen values reported from the surveyed laboratories in a single sample varied from 121 to 437 mg/dL. Because patients' results are interpreted in the context of nationally established cut points, the use of standardized assays for risk assessment of heart disease is essential. A single assay for the determination of SAA is currently available but is not approved by the FDA for clinical use and is not accessible to most clinical laboratories in the United States (7). CRP is a highly stable protein that has been measured in clinical laboratories for several decades using standardized and FDA-approved methods. Historically, however, this protein has been used to measure active infection or inflammation. The assays used for that purpose are reliable but lack the desired level of sensitivity needed to assess CRP concentration in apparently healthy subjects to determine their future risk of CHD. Therefore, over the last decade high-sensitivity CRP (hsCRP) methods have been developed, and currently more than 30 such methods are available worldwide (8). These methods are capable of



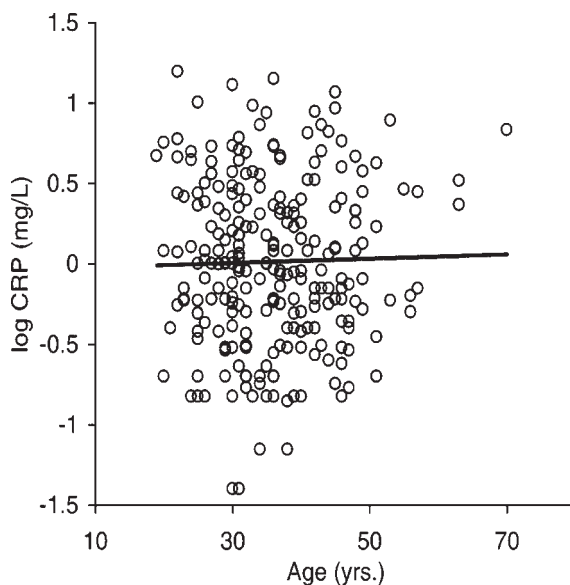
**Fig. 1.** Physiological and pathological span of CRP concentration (mg/L) and limits of detection of traditional and high-sensitivity assays.

reliably measuring CRP at concentrations  $\leq 0.3$  mg/L (Fig. 1), which corresponds to about the 5th percentile of normal population distribution. For the reasons presented, the AHA/CDC Laboratory Science Panel of the workshop on the use of markers of inflammation in cardiovascular disease concluded that of all the examined inflammatory biochemical markers, only CRP can make the transition from the research environment to routine clinical practice at the present time (9).

### *C-Reactive Protein*

CRP, a pentraxin, is composed of five identical and noncovalently bonded subunits, each consisting of 206 amino acid residues with a molecular mass of 23,017 kDa; thus, the total molecular mass of CRP is approx 118,000 kDa (10). The gene responsible for its synthesis is located on the proximal long arm of chromosome 1, at 7.7 kb, and is 2.5 kb long. The precise *in vivo* role of CRP is not totally clear; however, its properties are consistent with a fundamental role as a nonspecific defense mechanism. In response to tissue injury or infection, hepatocytes synthesize CRP after stimulation by cytokines, especially IL-6, IL-1  $\beta$ , and TNF- $\alpha$  (11). CRP binds to polysaccharides of many bacteria, fungi, and certain parasites in a calcium-dependent fashion, and once bound, it is a powerful activator of the classic complement system and can promote opsonization and phagocytosis of foreign substances. It is one of the most consistently increased and fastest-reacting acute-phase proteins (biological half-life of 19 h), suggesting that it is part of the innate immune response (12). CRP concentrations may rise 1000-fold or more within 24–48 h of tissue injury. Mild inflammation and viral infections generally cause CRP concentrations to increase to approx 10–50 mg/L, and active inflammation and bacterial infections result in concentrations between 50 and 200 mg/L (13) (Fig. 1). Concentrations  $>200$  mg/L are seen in more severe infections and in trauma.

Increases in CRP concentration, within the reference interval, are associated with future coronary events in apparently healthy men and women. These concentrations are below the detection limits of the traditional assays, because the median CRP values are about 1.5 mg/L for both men and women. The AHA/CDC guidelines defined specific cut points for clinical interpretation: CRP concentrations  $<1$  mg/L are considered low, 1–3 mg/L are average,



**Fig. 2.** Distribution of CRP concentration with age in healthy adults. (With permission from ref. 26.)

and  $>3$  mg/L indicate high relative risk, all of which are within the reference range of this protein (9).

## SOURCES OF VARIABILITY IN CRP TESTING

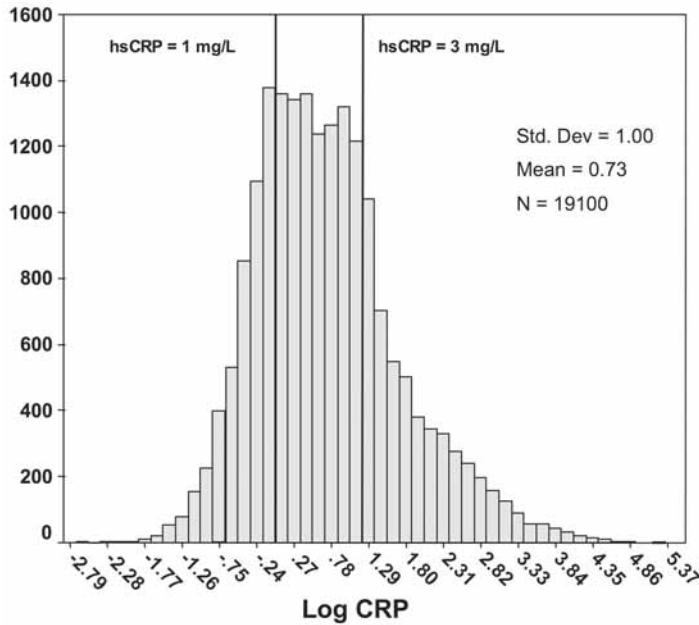
To reliably measure CRP for the purpose of assessing risk of future CHD, control and understanding of the various sources of preanalytic and analytic variability are necessary.

### *Preanalytic Variability*

#### PHYSIOLOGICAL AND CLINICAL

**Age, gender, and ethnicity.** Although most studies have shown no relationship between age and serum CRP concentration (7,14) (Fig. 2), at least two studies have reported a slight increase in CRP concentrations with age (15,16). This increase might be owing to the higher incidence of obesity that is associated with aging (15). In the Women's Health Study that included 15,770 participants, only a slight association of CRP with age was seen: median CRP concentrations for individuals 45–54, 55–64, 65–74, and  $\geq 75$  yr of age were 1.31, 1.89, 1.99, and 1.52 mg/L, respectively (17).

The availability of hsCRP assays has enabled the determination of population distributions of this protein. Several studies have shown that the distribution of CRP concentrations in both genders was non-Gaussian when evaluated for skewness and kurtosis (7,14) (Fig. 3). The AHA/CDC-proposed cut points correspond to the approximate tertiles of CRP distribution. Findings from American and European studies have shown comparable distributions of CRP concentrations among men and women not receiving hormone replacement therapy (HRT) (17–19) (Table 1). As indicated earlier, the 50th percentile of CRP is about 1.5 mg/L for both genders. Furthermore, data from the National Health and Nutrition Examination Survey III showed no significant difference in the distribution of CRP concentration among white, African American, and Mexican American men (18,19) (Table 2). Moreover, a comparable CRP distribution was seen in Japanese men (20) but not in Japanese women, who have a slightly lower CRP concentration. By contrast, other



**Fig. 3.** Combined distribution of CRP values from different population studies. (Courtesy of Dr. Gary Myers of the CDC.)

**Table 1**  
Population Distributions of CRP (mg/L)<sup>a</sup>

	Percentile						
	5th	10th	25th	50th	75th	90th	95th
American women <sup>b</sup>	0.2	0.3	0.6	1.5	3.5	6.6	9.1
American men	0.3	0.4	0.8	1.5	3.2	6.1	8.6
European women <sup>b</sup>	0.3	0.4	0.9	1.7	3.4	6.2	8.8
European men	0.3	0.6	0.8	1.6	3.3	6.5	8.6

<sup>a</sup>Data are from refs. 17 and 19.

<sup>b</sup>Only women not taking HRT.

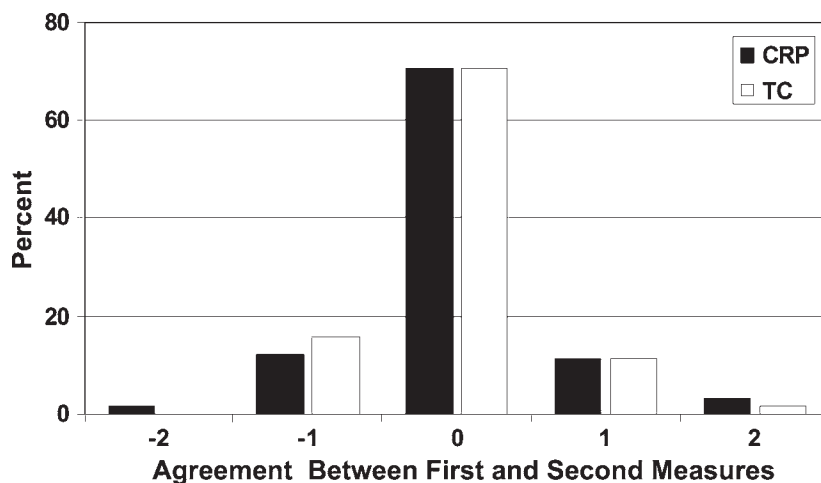
**Table 2**  
Distributions of CRP (mg/L) Among Men<sup>a</sup>

	Percentile						
	5th	10th	25th	50th	75th	90th	95th
White American	0.2	0.4	0.7	1.6	3.4	6.7	12.3
African American	0.1	0.2	0.7	1.7	3.9	8.2	13.2
Mexican American	0.2	0.4	0.6	1.6	3.2	6.3	9.8
Japanese	—	<0.3	0.4	1.6	3.5	7.8	—

<sup>a</sup>Data are from refs. 18 and 20.

studies have suggested that at least small differences in the distribution of CRP by ethnicity do exist (21). However, at present gender- or ethnic-specific cut points for CRP are not advocated.

**Seasonal and temporal.** There are limited data on CRP concentrations and seasonal cycles. Although one small study reported a slight variability in CRP concentration between



**Fig. 4.** Within-person variability for CRP vs total cholesterol (TC). (With permission from ref. 26.)

winter and summer (22), the SEASON study, which was specifically designed to examine seasonal changes in cardiovascular biomarkers, showed no consistent pattern of change in CRP concentrations (23).

It is well established that CRP has a relatively large biological variability. Therefore, the impact of this variability on the clinical utility of CRP in CHD risk assessment has been the subject of great interest. In two studies, the within-subject coefficient of variation (CV) ranged from 42 to 63% and the between-subject CV ranged from 76 to 92% (24,25), leading investigators to question the reliability of this marker in heart disease risk assessment. However, another study showed that the large intraindividual CV (averaging 30%) was acceptable when the estimated composite CV for the group of individuals was 120% (26). Nevertheless, given this biological variability, multiple blood sampling is recommended to establish an individual's baseline CRP. Some have advocated three independent determinations (25); however, findings from the SEASON trial showed that two independent measurements of CRP or total cholesterol, 3 months apart, enabled classification of up to 90% of subjects into the exact or immediately adjacent quartile (23). Additional analyses of these data have shown that >95% of subjects would be classified in the exact tertile of risk or vary by one tertile using the newly recommended cut points (27) (Fig. 4). Furthermore, in the Cholesterol and Recurrent Events trial, the age-adjusted correlation between two CRP measurements from blood samples drawn 5 yr apart was 0.6—again, a value comparable with that of cholesterol and other lipid parameters (28). Although continued skepticism surrounding the issue of intraindividual variation remains (29), the AHA/CDC expert panel concluded that the average of two independent measurements (fasting or nonfasting) of CRP taken at least 2 wk apart should be used to establish an individual's risk of CHD (9). Although it was initially recommended to repeat the measurement when the CRP concentration exceeds 10 mg/L (23), subsequent evidence suggests that the association of CRP with risk extends well beyond that range of concentration (30).

**Exercise, body mass, and other lifestyle behavior.** Several physiological conditions and lifestyle behaviors, such as exercise, obesity, cigarette smoking, and alcohol consumption, are known to affect CRP concentrations. Strenuous exercise, such as running a marathon, increases CRP concentrations acutely; however, an inverse association between CRP

concentration and levels of cardiorespiratory fitness has also been reported (31). In addition, a higher frequency of physical activity is associated with significantly lower odds of having increased CRP (32).

A positive association between CRP concentrations and body mass index has been clearly demonstrated (33,34). The relationships between CRP concentrations and measures of obesity have been reported to be consistent with in vivo release of IL-6 from adipose tissue. Significant weight reduction is associated with decreased concentrations of CRP, several cytokines, and adhesion molecules, thus indicating a reduction in the entire inflammatory state of an individual (35,36).

Numerous studies have documented an increased CRP concentration with cigarette smoking (37,38). This association is independent of cessation, suggesting that some of the smoking-related damage may be irreversible. In both the Physicians' Health Study (39) and the Women's Health Study (38), CRP was a good predictor of future myocardial infarction (MI) in both smokers and nonsmokers.

Moderate alcohol consumption is associated with lower CRP concentrations compared with no or occasional alcohol intake, suggesting that alcohol may attenuate the risk of CHD in part through anti-inflammatory mechanisms. Furthermore, IL-6 and TNF- $\alpha$  receptors 1 and 2 are lower in moderate drinkers than nondrinkers, further implicating anti-inflammatory effects of alcohol (40).

**Medications.** Several pharmacological agents and treatment modalities, including HRT, aspirin, and statins, influence CRP concentrations. In randomized clinical trials and cross-sectional studies, HRT increased serum CRP concentrations by two- to threefold (41–43). One study showed that although estrogen treatment resulted in significantly higher CRP concentrations, droloxifene exhibited no effect (44). In a prospective study in men, no effect of exogenous androgen therapy on serum inflammatory markers (including CRP) was observed, leading to the conclusion that a gender difference may exist regarding the effects of estrogen on serum inflammatory markers (45).

Although the effect of aspirin on reducing the incidence of MI in men with increased CRP (~60%) is clear (39), its effect on CRP concentration is uncertain. One study found a significant reduction in CRP concentration with the use of aspirin (46), but several others reported no change (47–49). By contrast, the statins have uniformly been shown to reduce concentrations of CRP by 15–20% (28,50,51).

### SPECIMEN COLLECTION AND HANDLING

There is no evidence to suggest that samples must be collected in the fasting state for the measurement of CRP (Table 3). However, certain assays are affected by optical clarity, and fasting before sampling may be needed in the presence of severe hypertriglyceridemia. Furthermore, CRP does not appear to exhibit a circadian rhythm and, therefore, there is no need to standardize the time for sample collection to assess the risk of CHD (52). Concern regarding diurnal variation of CRP stems from the fact that IL-6, which stimulates CRP synthesis, exhibits significant diurnal variation (53). However, the lack of diurnal variation of CRP may be owing to its relatively long half-life (19 h), which probably has blunted the circadian effect of IL-6.

Most commercially available immunoassays are suitable for either serum or plasma. However, the difference between these two fluids with respect to CRP testing is unclear. As expected, because of the osmotic shifting effect of the anticoagulant on erythrocytes, the use of EDTA or citrated plasma specimens resulted in significant biases (>10%) in CRP



Table 3  
Practical Considerations in CRP Testing

---

- *What type of specimen should be used?*  
Serum values equivalent to heparinized plasma  
EDTA <5% and citrate <10% than serum
- *Should the patient be fasting?*  
No: fasting ( $6.6 \pm 13.5$  mg/L) vs nonfasting ( $6.3 \pm 14$  mg/L) ( $n = 10$ ;  $p < 0.37$ )
- *Should the time for sample collection be standardized?*  
No: no circadian rhythm exhibited for CRP
- *How should CRP results be reported and interpreted?*  
In mg/L: values <1 = low, 1–3 = average, >3 = high risk of CHD

---

concentration when compared with serum in one study (54). By contrast, no difference in CRP values was seen using heparinized and serum samples (55). Another study, however, showed no significant differences when serum and heparin- or EDTA-plasma samples were simultaneously collected from a single stick in 25 patients (56). Additional studies are needed to clarify this important issue.

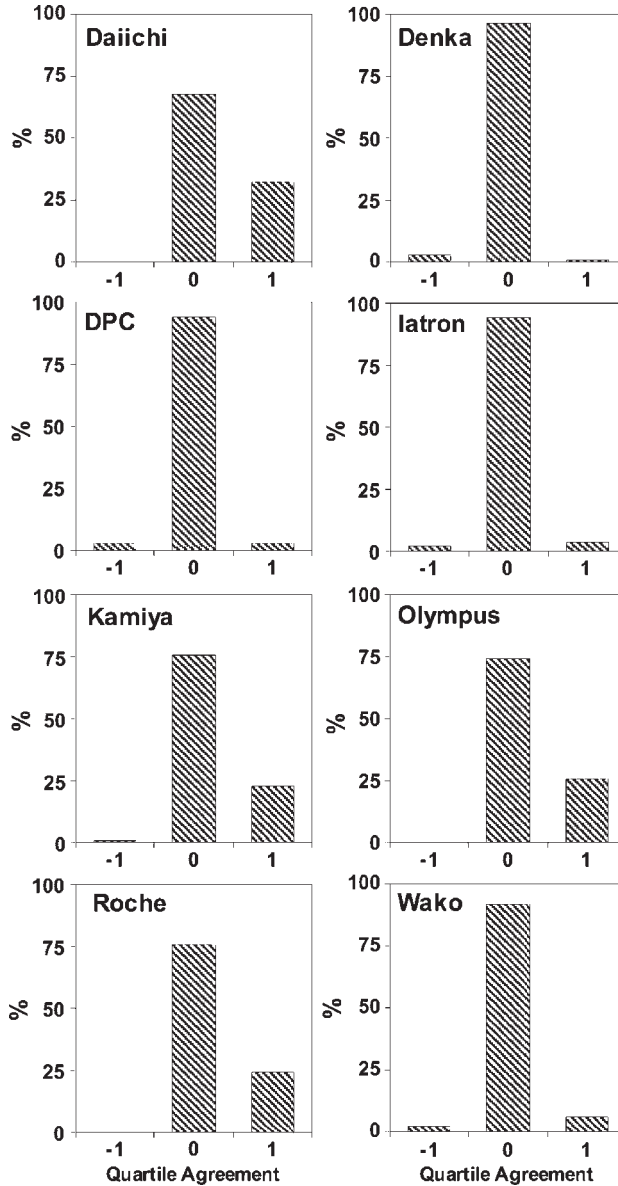
CRP has been shown to be stable at 4°C for 60 d (57), and no significant changes in its concentration were seen in samples stored at –70°C for more than 20 yr (58) or in liquid nitrogen for up to 6 mo (17).

### *Analytic Variability*

hsCRP methods were developed in order to reliably measure this protein at concentrations seen in apparently healthy individuals. Investigators improved the performance of CRP assays by using fluorescent, luminescent, or radioactive adducts to antibodies to enhance the immunoprecipitate and improve the signal. The most successful of these approaches was the amplification of the light-scattering properties of the antigen-antibody complex by covalently coupling latex particles to specific antibody (7). This technology gained wide acceptance among clinical laboratories because it enabled adaptation of the assay to the routine automated chemistry analyzers. Because subjects are classified into categories of risk using specific cut points of CRP concentration (9), assays must be able to reliably measure CRP at least at the lowest cut point (1 mg/L). Assays used for population-based studies and clinical research, however, should be able to measure CRP concentrations at much lower concentrations, such as 0.15 mg/L (2.5th percentile of the reference population). An evaluation of nine second-generation hsCRP assays showed that all had a sensitivity of  $\leq 0.3$  mg/L (59). The sensitivity of the current hsCRP assays does not appear to be an issue that hampers the clinical use of this test for assessing the risk of CHD. The reliability of a particular assay is in part a function of its reproducibility. It has been suggested that for hsCRP, the within-laboratory total imprecision should be <10% across the linear range of the assay (60). However, in the aforementioned evaluation, only five of the nine hsCRP methods examined met this criterion, thus indicating the need for more precise assays (59).

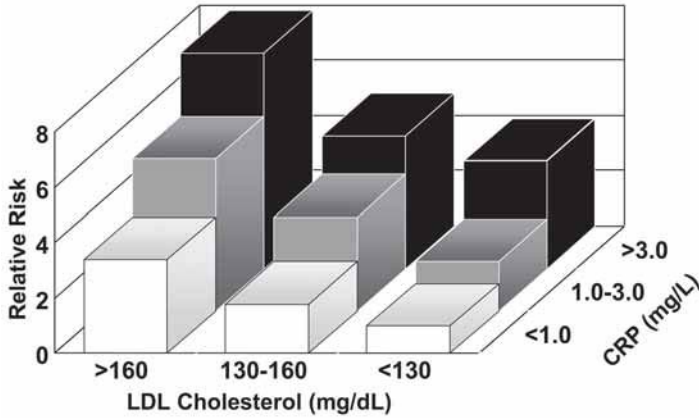
### *Standardization and Reporting*

More than 30 commercially available hsCRP methods are used worldwide (8). The performance of the various methods differs. In fact, studies using various assays have had



**Fig. 5.** Agreement among various hsCRP methods using sample from apparently healthy individuals. The Dade-Behring hsCRP method was used as the comparison method. (With permission from ref.58.)

significant discrepancy in reported results and emphasized the need for additional standardization (59,60). For example, in one evaluation study, four of the hsCRP methods were in excellent agreement with the comparison method in classifying subjects into quartiles of risk (59) (Fig. 5). In fact, 92–95% of subjects were classified by these methods into the exact quartile and the remaining 5–8% fell almost equally into the adjacent two quartiles. Using the other four methods, however, only 65–75% of subjects were classified into the exact quartile, and the remaining 25–35% fell into the adjacent upper quartile, indicating a problem with standardization. Agreement among the various hsCRP methodologies



**Fig. 6.** Algorithm for risk assessment of CHD. CRP cut points are those recommended by the AHA/CDC expert panel and LDL cholesterol cut points are those recommended by the National Cholesterol Education Program. Risk estimates are not adjusted for other CHD risk factors. (With permission from ref. 17.)

is essential, considering that the individual patient's results will be interpreted within the context of nationally established cut points. To address this issue, the CDC initiated a standardization program to which manufacturers of all hsCRP reagents worldwide have been invited to participate (8). Phase I of this project aimed to identify a suitable reference material. The use of a common calibrator among the various assays usually leads to a harmonization of patients' results. Such a calibrator has now been identified—CRM 470—after making the appropriate dilution (8). Phase II of the study will involve the use of the common calibrator to demonstrate the lack of discrepancy among the various assays in freshly collected patient samples.

In addition to establishing clinical cut points for risk assessment, the AHA/CDC expert panel chose milligrams per liter as the unit of choice for reporting results (9) (Table 3). It is imperative that CRP values be reported in a single consistent unit. If some laboratories report CRP concentration in milligrams per liter and others in milligrams per deciliter, confusion will exist in the medical community in terms of interpreting this marker, and patients will be misclassified and mismanaged. It is the responsibility of laboratorians to provide and clinicians to demand such consistence of measurement nomenclature.

## INTERPRETATION OF CRP RESULTS

The AHA/CDC expert panel has recommended the use of specific cut points for clinical interpretation (9). Several studies have demonstrated that CRP results are additive to lipids in terms of predicting an individual's risk of CHD (4,61,62). Therefore, it has been suggested that both be combined in an algorithm for risk assessment of heart disease (17). Using CRP values recommended by the AHA/CDC expert panel (low: <1 mg/L; average: 1–3 mg/L; high:  $\geq 3$  mg/L) and low-density lipoprotein (LDL) cholesterol values recommended by the National Cholesterol Education Program (low: <130 mg/dL; average: 130–160 mg/dL; high:  $\geq 160$  mg/dL), risk estimates for both genders were derived from databases of the Physicians' Health Study and the Women's Health Study (Fig. 6). This algorithm may serve as an additional tool for clinicians in the global risk assessment of CHD.

## CONCLUSION

Although CRP was discovered more than 70 yr ago and has been used for several decades as a marker of active infection and inflammation, a new role for this protein has emerged. Prospective studies have consistently shown that slight increases in CRP concentrations in apparently healthy individuals are a strong predictor of the risk of CHD independent of lipid levels. hsCRP assays were developed for that purpose, and national guidelines were established to include CRP in the global risk assessment of CHD. Because an individual's CRP concentration is interpreted according to fixed cut points, available methods must be standardized to avoid misclassification of patients into categories of risk. Furthermore, advances in the understanding of preanalytic and analytic sources of variations and a successful effort at standardization will undoubtedly lead to improvement in the measurement and classification of CRP.

## REFERENCES

1. Biasucci LM, Vitelli A, Liuzzo G, et al. Elevated levels of interleukin-6 in unstable angina. *Circulation* 1996;94:874–877.
2. Blankenberg S, Luc G, Ducimetiere P, et al. Interleukin-18 and the risk of coronary heart disease in European men: the Prospective Epidemiological Study of Myocardial Infarction (PRIME). *Circulation* 2003;108:2453–2459.
3. Ridker PM, Buring JE, Rifai N. Soluble P-selectin and the risk of future cardiovascular events. *Circulation* 2001;103:491–495.
4. Ridker PM, Hennekens CH, Buring JE, Rifai N. C-reactive protein and other markers of inflammation in the prediction of cardiovascular disease in women. *N Engl J Med* 2000;342:836–843.
5. Johnson BD, Kip KE, Marroquin OC, et al. Serum amyloid A as a predictor of coronary artery disease and cardiovascular outcome in women: the National Heart, Lung, and Blood Institute-Sponsored Women's Ischemia Syndrome Evaluation (WISE). *Circulation* 2004;109:726–732.
6. Danesh J, Muir J, Wong YK, Ward M, Gallimore JR, Pepys MB. Risk factors for coronary heart disease and acute-phase proteins: a population-based study. *Eur Heart J* 1999;20:954–959.
7. Ledue TB, Weiner DL, Sipe JD, Poulin SE, Collins MF, Rifai N. Analytical evaluation of particle-enhanced immunonephelometric assays for C-reactive protein, serum amyloid A and mannose-binding protein in human serum. *Ann Clin Biochem* 1998;35:745–753.
8. Kimberly MM, Vesper HW, Caudill SP, et al. Standardization of immunoassays for measurement of high-sensitivity C-reactive protein (hsCRP). Phase I: evaluation of secondary reference materials. *Clin Chem* 2003;49:611–616.
9. Pearson TA, Mensah GA, Alexander RW, et al. Markers of inflammation and cardiovascular disease: application to clinical and public health practice: a statement for healthcare professionals from the Centers for Disease Control and Prevention and the American Heart Association. *Circulation* 2003;107:499–511.
10. Pepys MB, Hirschfield GM. C-reactive protein: a critical update. *J Clin Invest* 2003;111:1805–1812.
11. Castell JV, Gomez-Lechon MJ, David M, Fabra R, Trullenque R, Heinrich PC. Acute-phase response of human hepatocytes: regulation of acute-phase protein synthesis by interleukin-6. *Hepatology* 1990;12:1179–1186.
12. Hoffmann JA, Kafatos FC, Janeway CA, Ezekowitz RA. Phylogenetic perspectives in innate immunity. *Science* 1999;284:1313–1318.
13. Clyne B, Olshaker JS. The C-reactive protein. *J Emerg Med* 1999;6:1019–1025.
14. Erlandsen EJ, Randers E. Reference interval for serum C-reactive protein in healthy blood donors using the Dade Behring N Latex CRP mono assay. *Scand J Clin Lab Invest* 2000;60:37–43.
15. Hutchinson WL, Köenig W, Frohlich M, Sund M, Lowe GD, Pepys MB. Immunoradiometric assay of circulating C-reactive protein: age-related values in the adult general population. *Clin Chem* 2000;46:934–938.
16. Herberth B, Siest G, Henny J. High-sensitivity C-reactive protein (CRP) reference intervals in the elderly. *Clin Chem Lab Med* 2001;11:1169, 1170.
17. Rifai N, Ridker PM. Population distributions of C-reactive protein in apparently healthy men and women in the United States: implication for clinical interpretation. *Clin Chem* 2003;49:666–669.

18. Ford ES, Giles WH, Myers GL, Mannino DM. Population distribution of high-sensitivity C-reactive protein among US men: findings from National Health and Nutrition Examination Survey 1999–2000. *Clin Chem* 2003;49:686–690.
19. Imhof A, Frohlich M, Loewel H, et al. Distributions of C-reactive protein measured by high-sensitivity assays in apparently healthy men and women from different populations in Europe. *Clin Chem* 2003;49:669–672.
20. Yamada S, Gotoh T, Nakashima Y, et al. Distribution of serum C-reactive protein and its association with atherosclerotic risk factors in a Japanese population: Jichi Medical School Cohort Study. *Am J Epidemiol* 2001;153:1183–1190.
21. Albert MA, Glynn RJ, Buring J, Ridker PM. C-reactive protein levels among women of various ethnic groups living in the United States (from the Women's Health Study). *Am J Cardiol* 2004;93:1238–1242.
22. Crawford VL, Sweeney O, Coyle PV, Halliday IM, Stout RW. The relationship between elevated fibrinogen and markers of infection: a comparison of seasonal cycles. *QJM* 2000;93:745–750.
23. Ockene IS, Matthews CE, Rifai N, Ridker PM, Reed G, Stanek E. Variability and classification accuracy of serial high-sensitivity C-reactive protein measurements in healthy adults. *Clin Chem* 2001;47:444–450.
24. Clark GH, Fraser CG. Biological variation of acute phase proteins. *Ann Clin Biochem* 1993;30:373–376.
25. Macy EM, Hayes TE, Tracy RP. Variability in the measurement of C-reactive protein in healthy subjects: implications for reference intervals and epidemiological applications. *Clin Chem* 1997;43:52–58.
26. Kluff C, de Maat MP. Determination of the habitual low blood level of C-reactive protein in individuals. *Ital Heart J* 2001;2:172–180.
27. Ledue TB, Rifai N. Preanalytic and analytic sources of variations in C-reactive protein measurement: implications for cardiovascular disease risk assessment. *Clin Chem* 2003;49:1258–1271.
28. Ridker PM, Rifai N, Pfeffer MA, et al. Inflammation, pravastatin, and the risk of coronary events after myocardial infarction in patients with average cholesterol levels. Cholesterol and Recurrent Events (CARE) Investigators. *Circulation* 1998;98:839–844.
29. Campbell B, Badrick T, Flatman R, Kanowski D. Limited clinical utility of high-sensitivity plasma C-reactive protein assays. *Ann Clin Biochem* 2002;39:85–88.
30. Ridker PM, Cook N. Clinical usefulness of very high and very low levels of C-reactive protein across the full range of Framingham Risk Scores. *Circulation* 2004;109:1955–1959.
31. Weight LM, Alexander D, Jacobs P. Strenuous exercise: analogous to the acute-phase response? *Clin Sci (Lond)* 1991;81:677–683.
32. Church TS, Barlow CE, Earnest CP, Kampert JB, Priest EL, Blair SN. Associations between cardiorespiratory fitness and C-reactive protein in men. *Arterioscler Thromb Vasc Biol* 2002;22:1869–1876.
33. Ford ES. Body mass index, diabetes, and C-reactive protein among U.S. adults. *Diabetes Care* 1999;22:1971–1977.
34. Visser M, Bouter LM, McQuillan GM, Wener MH, Harris TB. Elevated C-reactive protein levels in overweight and obese adults. *JAMA* 1999;282:2131–2135.
35. Tchernof A, Nolan A, Sites CK, Ades PA, Poehlman ET. Weight loss reduces C-reactive protein levels in obese postmenopausal women. *Circulation* 2002;105:564–569.
36. Ziccardi P, Nappo F, Giugliano G, et al. Reduction of inflammatory cytokine concentrations and improvement of endothelial functions in obese women after weight loss over one year. *Circulation* 2002;105:804–809.
37. Tracy RP, Psaty BM, Macy E, et al. Lifetime smoking exposure affects the association of C-reactive protein with cardiovascular disease risk factors and subclinical disease in healthy elderly subjects. *Arterioscler Thromb Vasc Biol* 1997;17:2167–2176.
38. Bermudez EA, Rifai N, Buring JE, Manson JE, Ridker PM. Relation between markers of systemic vascular inflammation and smoking in women. *Am J Cardiol* 2002;89:1117–1119.
39. Ridker PM, Cushman M, Stampfer MJ, Tracy RP, Hennekens CH. Inflammation, aspirin, and the risk of cardiovascular disease in apparently healthy men. *N Engl J Med* 1997;336:973–979.
40. Albert MA, Glynn RJ, Ridker PM. Alcohol consumption and plasma concentration of C-reactive protein. *Circulation* 2003;107:443–447.
41. Cushman M, Legault C, Barrett-Connor E, et al. Effect of postmenopausal hormones on inflammation-sensitive proteins: the Postmenopausal Estrogen/Progestin Interventions (PEPI) Study. *Circulation* 1999;100:717–722.
42. Cushman M, Meilahn EN, Psaty BM, Kuller LH, Dobs AS, Tracy RP. Hormone replacement therapy, inflammation, and hemostasis in elderly women. *Arterioscler Thromb Vasc Biol* 1999;19:893–899.
43. Ridker PM, Hennekens CH, Rifai N, Buring JE, Manson JE. Hormone replacement therapy and increased plasma concentration of C-reactive protein. *Circulation* 1999;100:713–716.

44. Herrington DM, Brosnihan KB, Pusser BE, et al. Differential effects of E and droloxifene on C-reactive protein and other markers of inflammation in healthy postmenopausal women. *J Clin Endocrinol Metab* 2001;86:4216–4222.
45. Ng MK, Liu PY, Williams AJ, et al. Prospective study of effect of androgens on serum inflammatory markers in men. *Arterioscler Thromb Vasc Biol* 2002;22:1136–1141.
46. Ikonomidis I, Andreotti F, Economou E, Stefanadis C, Toutouzas P, Nihoyannopoulos P. Increased pro-inflammatory cytokines in patients with chronic stable angina and their reduction by aspirin. *Circulation* 1999;100:793–798.
47. Feng D, Tracy RP, Lipinska I, Murillo J, McKenna C, Tofler GH. Effect of short-term aspirin use on C-reactive protein. *J Thromb Thrombolysis* 2000;9:37–41.
48. Feldman M, Jialal I, Devaraj S, Cryer B. Effects of low-dose aspirin on serum C-reactive protein and thromboxane  $\beta_2$  concentrations: a placebo-controlled study using a highly sensitive C-reactive protein assay. *J Am Coll Cardiol* 2001;37:2036–2041.
49. Ferroni P, Martini F, Cardareello CM, Gazzaniga PP, Davi G, Basili S. Enhanced interleukin-1beta in hypercholesterolemia: effects of simvastatin and low-dose aspirin. *Circulation* 2003;108:1673–1675.
50. Ridker PM, Rifai N, Clearfield M, et al. Measurement of C-reactive protein for the targeting of statin therapy in the primary prevention of acute coronary events. *N Engl J Med* 2001;344:1959–1965.
51. Jialal I, Stein D, Balis D, Grundy SM, Adams-Huet B, Devaraj S. Effect of hydroxymethyl glutaryl co-enzyme a reductase inhibitor therapy on high sensitive C-reactive protein levels. *Circulation* 2001;103:1933–1935.
52. Meier-Ewert HK, Ridker PM, Rifai N, Price N, Dinges DF, Mullington JM. Absence of diurnal variation of C-reactive protein concentrations in healthy human subjects. *Clin Chem* 2001;47:426–430.
53. Gudewill S, Pollmacher T, Vedder H, Schreiber W, Fassbender K, Holsboer F. Nocturnal plasma levels of cytokines in healthy men. *Eur Arch Psychiatry Clin Neurosci* 1992;242:53–56.
54. Ledue TB, Rifai N. High sensitivity immunoassays for C-reactive protein: promises and pitfalls. *Clin Chem Lab Med* 2001;39:1171–1176.
55. Roberts WL, Schwarz EL, Ayanian S, Rifai N. Performance characteristics of a point of care C-reactive protein assay. *Clin Chim Acta* 2001;314:255–259.
56. Rothkrantz-Kos S, Schmitz MP, Bekers O, Menheere PP, van Dieijen-Visser MP. High-sensitivity C-reactive protein methods examined. *Clin Chem* 2002;48:359–362.
57. Kebler A, Grunert C, Wood WC. The limitation and usefulness of C-reactive protein and elastase- $\alpha$ 1 proteinase inhibitor complexes as analytes in the diagnosis and followup of sepsis in newborns and adults. *Eur J Clin Chem Biochem* 1994;32:365–368.
58. Wilkins J, Gallimore JR, Moore EG, Pepys MB. Rapid automated high sensitivity enzyme immunoassay of C-reactive protein. *Clin Chem* 1998;44:1358–1361.
59. Roberts WL, Moulton L, Law TC, et al. Evaluation of nine automated high-sensitivity C-reactive protein methods: implications for clinical and epidemiological applications. Part 2. *Clin Chem* 2001;47:418–425.
60. Roberts WL, Sedrick R, Moulton L, Spencer A, Rifai N. Evaluation of four automated high-sensitivity C-reactive protein methods: implications for clinical and epidemiological applications. *Clin Chem* 2000;46:461–468.
61. Ridker PM, Glynn RJ, Hennekens CH. C-reactive protein adds to the predictive value of total and HDL cholesterol in determining risk of first myocardial infarction. *Circulation* 1998;97:2007–2011.
62. Ridker PM, Rifai N, Rose L, Buring JE, Cook NR. Comparison of C-reactive protein and low-density lipoprotein cholesterol levels in the prediction of first cardiovascular events. *N Engl J Med* 2002;347:1557–1565.



# 16

---

## C-Reactive Protein as a Tool for Risk Assessment in Primary Prevention

---

*Shari S. Bassuk, ScD  
and Paul M Ridker, MD, MPH*

### CONTENTS

NOVEL RISK FACTORS AND CARDIOVASCULAR RISK PREDICTION  
PATHOPHYSIOLOGY OF CRP  
hsCRP AND CARDIOVASCULAR RISK:  
    EPIDEMIOLOGICAL AND CLINICAL DATA  
PRACTICAL CONSIDERATIONS  
THERAPEUTIC INTERVENTIONS  
CLINICAL RECOMMENDATIONS  
REFERENCES

---

### SUMMARY

High-sensitivity C-reactive protein (hsCRP) is a marker of inflammation that predicts incident myocardial infarction, stroke, peripheral arterial disease, and sudden cardiac death among healthy persons without a history of cardiovascular disease, as well as recurrent events and death in patients with acute or stable coronary syndromes. hsCRP adds prognostic value at all levels of low-density lipoprotein cholesterol, Framingham coronary risk score, severity of the metabolic syndrome, and blood pressure, and in those with and without subclinical atherosclerosis. Among apparently healthy men and women, hsCRP levels of less than 1, 1 to 3, and greater than 3 mg/L distinguish those at low, moderate, and high risk for future cardiovascular disease, respectively. In clinical settings, hsCRP should be used in conjunction with lipid evaluation as part of global risk assessment. Improved knowledge of cardiovascular risk should lead to better compliance with lifestyle and pharmacological interventions designed to prevent future cardiovascular events.

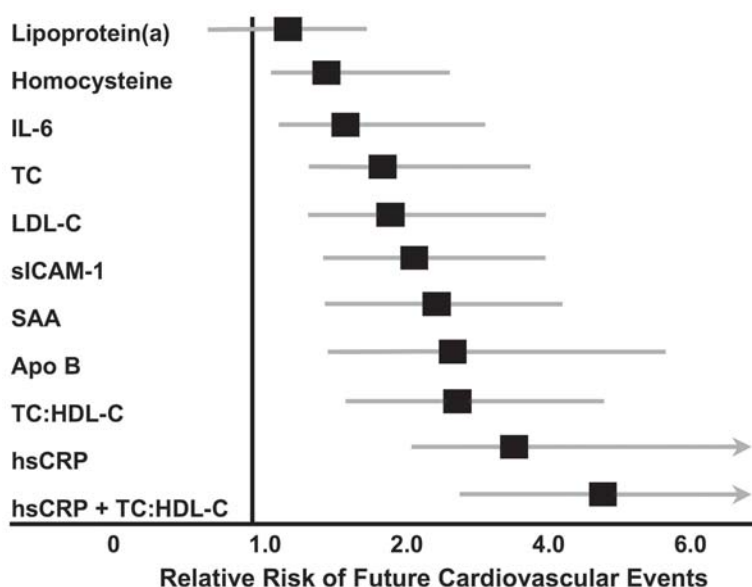
**Key Words:** C-reactive protein; cardiovascular disease; clinical medicine; epidemiology; inflammation; risk assessment.

### NOVEL RISK FACTORS AND CARDIOVASCULAR RISK PREDICTION

Identifying asymptomatic individuals at high risk of developing a first cardiovascular disease (CVD) event is a critical issue in primary prevention. Although the use of global

From: *Contemporary Cardiology:  
Cardiovascular Biomarkers: Pathophysiology and Disease Management*  
Edited by: David A. Morrow © Humana Press Inc., Totowa, NJ

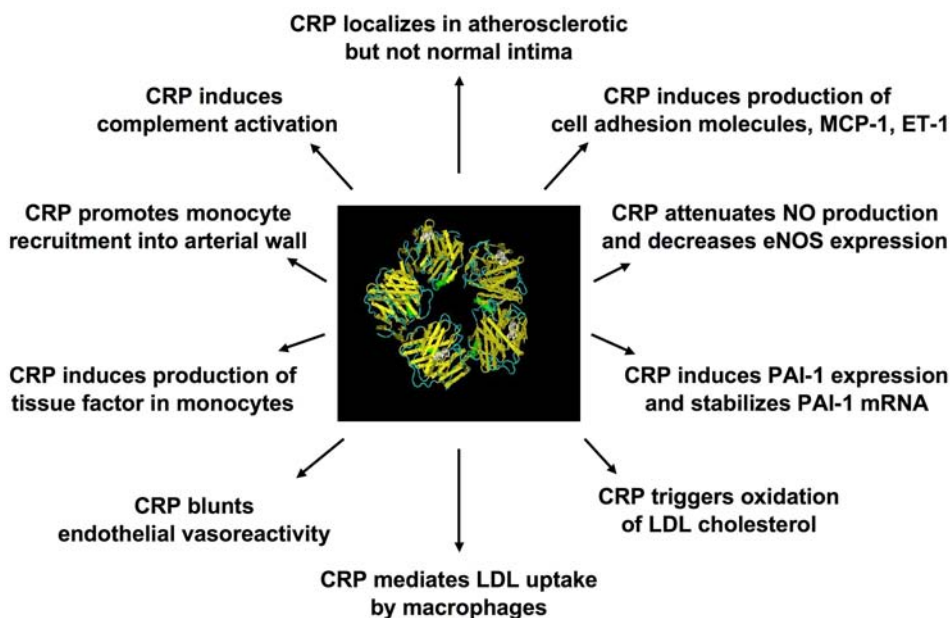




**Fig. 1.** Head-to-head comparison of various biomarkers in cardiovascular risk prediction. TC, total cholesterol; sICAM-1, soluble intercellular adhesion molecule type 1; SAA, serum amyloid A; Apo B, apolipoprotein B-100. (Adapted from ref. 10.)

prediction algorithms such as those derived from the Framingham Heart Study (1) greatly improves the assessment of heart disease risk in primary prevention settings, as many as 20% of all coronary events occur in the absence of any of the major classic vascular risk factors. In a recent analysis of more than 120,000 patients with coronary heart disease (CHD), 15% of the men and 19% of the women had no evidence of hyperlipidemia, hypertension, diabetes, or smoking, and more than half had only one of these traditional risk factors (2). In another large population, between 85 and 95% of participants with CHD had at least one conventional risk factor, but so too did those participants without CHD, despite follow-up for as long as three decades (3). Because of the considerable need to improve risk detection, the identification of novel atherosclerotic risk factors has been a major goal of cardiovascular research in recent years (4,5).

In a recent monograph, we examined the evidence for high-sensitivity C-reactive protein (hsCRP) as a potential adjunct for cardiovascular risk prediction (6); this chapter updates and summarizes that detailed review. When evaluating a novel biomarker as a potential screening tool, clinicians should consider whether a standardized, reproducible, and cost-efficient assay for the biomarker exists; whether prospective data show that the biomarker consistently predicts future risk; and whether adding the biomarker to existing global risk prediction algorithms significantly improves prognostic ability. Clinicians should also weigh the relative magnitude of candidate biomarkers in terms of risk prediction. Application of these standards to a series of novel risk factors indicates that, to date, hsCRP is the most promising with respect to clinical utility (7–9). For example, in a direct comparison of the relative ability of various biomarkers, including lipid fractions, to predict future CVD (a combined end point of CHD death, nonfatal myocardial infarction [MI], stroke, and coronary revascularization) in the Women’s Health Study, an 8-yr follow-up of 28,000 middle-aged women, hsCRP emerged as the most powerful single predictor of cardiovascular risk (Fig. 1) (10). The same result was obtained for the outcome of periph-



**Fig. 2.** Mechanisms relating CRP to development and progression of atherothrombosis. eNOS, endothelial nitric oxide synthase. (Reproduced from ref. [110](#).)

eral arterial disease ([11](#)). Moreover, prediction models that incorporated hsCRP in addition to lipid profile were significantly better than models based on lipids alone—a not entirely unexpected finding given that 77% of cardiovascular events occurred among women with low-density lipoprotein cholesterol (LDL-C) levels of <160 mg/dL, and 46% occurred among those with LDL-C levels <130 mg/dL ([12](#)). Although other markers of inflammation, including cytokines such as interleukin (IL)-6 ([13](#)) and tumor necrosis factor- $\alpha$  ([14](#)); cell adhesion molecules such as soluble intercellular adhesion molecule-1 ([15,16](#)), P-selectin ([17](#)), and soluble CD40 ligand ([18](#)); macrophage inhibitory cytokine-1 ([19](#)); lipoprotein-associated phospholipase A<sub>2</sub> ([20,21](#)); and white blood cell count ([22](#)) have also shown promise as markers of vascular risk, they each have analytic shortcomings that preclude their use in general clinical practice. For example, the half-life of several of these markers is too short for diagnostic testing in this setting, whereas the ability of others to predict risk in population-based studies after adjustment for traditional risk factors has been marginal ([23,24](#)).

## PATHOPHYSIOLOGY OF CRP

Atherothrombosis is now recognized as a chronic inflammatory disease, and accumulating data indicate a potential role for CRP at all stages of the atherosclerotic process ([Fig. 2](#)). A member of the pentraxin family of innate immune response proteins, CRP not only is synthesized in the liver in response to IL-6 but may also be produced by smooth muscle cells within coronary arteries ([25–27](#)). Laboratory studies suggest that CRP may directly influence vascular vulnerability via many mechanisms, including enhanced expression of local endothelial cell surface adhesion molecules ([28](#)), monocyte chemoattractant protein-1 (MCP-1) ([28,29](#)), endothelin-1 (ET-1) ([30](#)), and endothelial plasminogen activator inhibitor-1 (PAI-1) ([31](#)); reduced endothelial nitric oxide (NO) bioactivity

(30,32,33); increased induction of tissue factor in monocytes (34); increased LDL uptake by macrophages (35); and colocalization with the complement membrane attack complex within atherosclerotic lesions (36). The expression of human CRP in CRP-transgenic mice directly enhances intravascular thrombosis in arterial injury and photochemical injury models of endothelial disruption (37). The clinical relevance of these observations, however, remains controversial.

### hsCRP AND CARDIOVASCULAR RISK: EPIDEMIOLOGICAL AND CLINICAL DATA

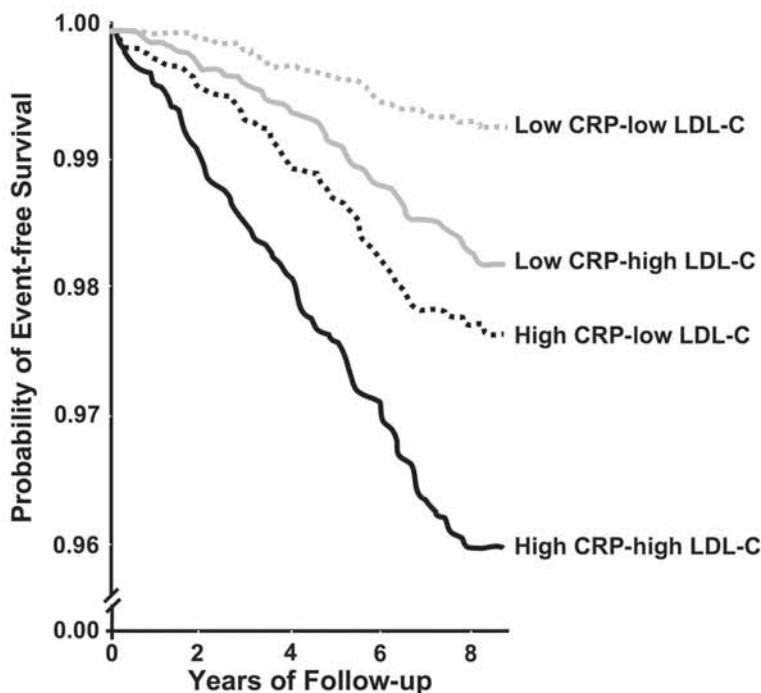
Although the exact physiological role of CRP remains unclear, the prognostic value of hsCRP as a marker of cardiovascular risk is firmly established. hsCRP predicts future cardiovascular risk in healthy individuals without CVD; patients with acute coronary syndrome (ACS), stable angina or in the stable phase following MI; and patients with metabolic syndrome, diabetes, or renal disease.

#### *hsCRP and Risk of Cardiovascular Events in Primary Prevention*

Prospective epidemiological studies indicate that hsCRP is a predictor of MI or CHD mortality (10,12,20,21,38–58), stroke (10,12,39,41,42,59–62), peripheral vascular disease (11,63), congestive heart failure (64,65), atrial fibrillation (66), and sudden cardiac death (67). The association between hsCRP and subsequent CVD has been observed in men and women, in the middle aged and elderly, in high- and usual-risk populations, and in the United States and Europe. The relation is apparent even after many years of follow-up. For example, elevated hsCRP levels at baseline were predictive of 17-yr coronary mortality in the Multiple Risk Factor Intervention Trial (38) and sudden cardiac death in the Physicians' Health Study (67). Among Japanese-American men participating in the Honolulu Heart Program, hsCRP was a strong predictor of MI (53) and thromboembolic stroke (61) up to two decades after initial blood samples were collected.

Epidemiological studies generally indicate that persons with baseline hsCRP levels in the top quartile of the sample distribution have a two- to threefold increase in the likelihood of experiencing a future vascular event than those in the bottom hsCRP quartile. In most instances, the association between hsCRP and subsequent vascular events has a linear “dose–response” shape and is independent of the risk factors commonly assessed in clinical settings and included in global cardiovascular prediction algorithms such as those derived from the Framingham Heart Study—age, smoking, hypertension, dyslipidemia, and diabetes. In 2000, a meta-analysis of 14 prospective studies (2557 cases; mean follow-up of 8 yr) of hsCRP and risk of nonfatal MI or CHD death yielded a summary relative risk (RR) of 1.9 (95% confidence interval [CI]: 1.5–2.3) for individuals in the top tertile of baseline hsCRP compared with those in the bottom tertile (45). Each of the studies included in the meta-analysis adjusted for smoking and “some standard vascular risk factors.”

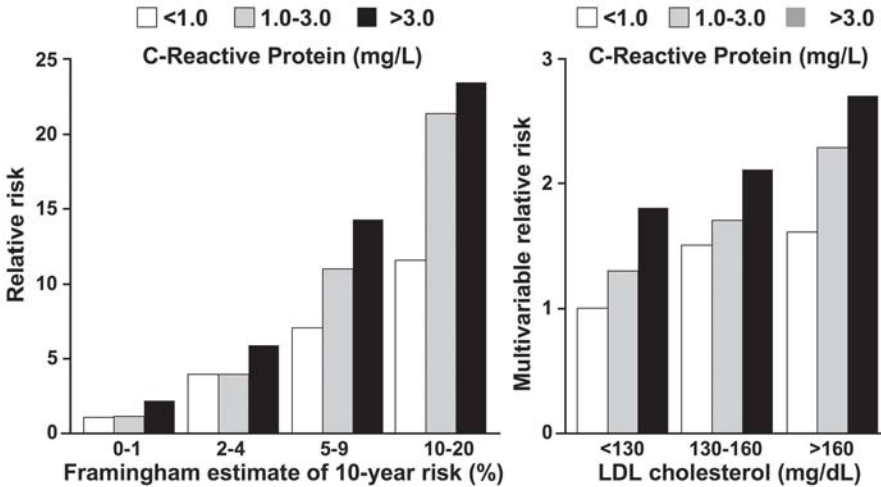
More recently, findings from several major prospective studies, including the Women's Health Study (12), the Atherosclerosis Risk in Communities (ARIC) study (21), the Nurses' Health Study (58), and the Health Professionals Follow-up Study (58) in the United States; the Monitoring of Trends and Determinants in Cardiovascular Disease (MONICA) Augsburg study in Germany (56); and the Reykjavik Study in Iceland (57), have conclusively demonstrated that hsCRP provides prognostic information beyond that available from traditional cardiovascular risk factors. In these studies, hsCRP levels were interpreted in



**Fig. 3.** Cardiovascular event-free survival according to baseline levels of hsCRP and LDL-C. (Reproduced from ref. 12.)

terms of either population-based quintiles or simple cut points. The latter approach, in which hsCRP levels  $<1$ ,  $1-3$ , and  $>3$  mg/L represent lower-, moderate-, and higher-risk groups, provides comparable predictive utility to that of the former approach and has greater clinical appeal.

The largest of the US studies is the Women's Health Study, an 8-yr follow-up of 27,939 initially healthy middle-aged women who underwent hsCRP evaluation along with a full lipid panel and Framingham risk assessment. After adjustment for age, smoking, diabetes, blood pressure, and postmenopausal hormone therapy, the RR of a first cardiovascular event for women in the lowest to highest quintiles of hsCRP at baseline ( $\leq 0.49$ ,  $>0.49-1.08$ ,  $>1.08-2.09$ ,  $>2.09-4.19$ ,  $>4.19$  mg/L) were 1.0 (referent), 1.4 (95% CI: 0.9–2.2), 1.6 (95% CI: 1.1–2.4), 2.0 (95% CI: 1.3–3.0), and 2.3 (95% CI: 1.6–3.4). hsCRP levels were minimally correlated with LDL-C, and a combined approach using both variables yielded improved prediction of cardiovascular event-free survival. Figure 3 shows cardiovascular event-free survival data for participants with LDL-C above or below the study median of 124 mg/dL and hsCRP above or below the study median of 1.52 mg/L (12). As expected, event-free survival was poorest for persons with elevations in both LDL-C and hsCRP, whereas the best survival was observed for those with low values on both tests. Women with an elevated reading on only one test had an intermediate risk. However, contrary to many clinicians' expectations, event-free survival was significantly worse for those with high hsCRP and low LDL-C compared with those with high LDL-C and low hsCRP, suggesting that hsCRP may be a stronger predictor than LDL-C of incident CVD. More important, as shown in Fig. 4, hsCRP, categorized as  $<1$ ,  $1-3$ , and  $>3$  mg/L, adds prognostic information not only at all levels of risk defined by the current LDL cut points

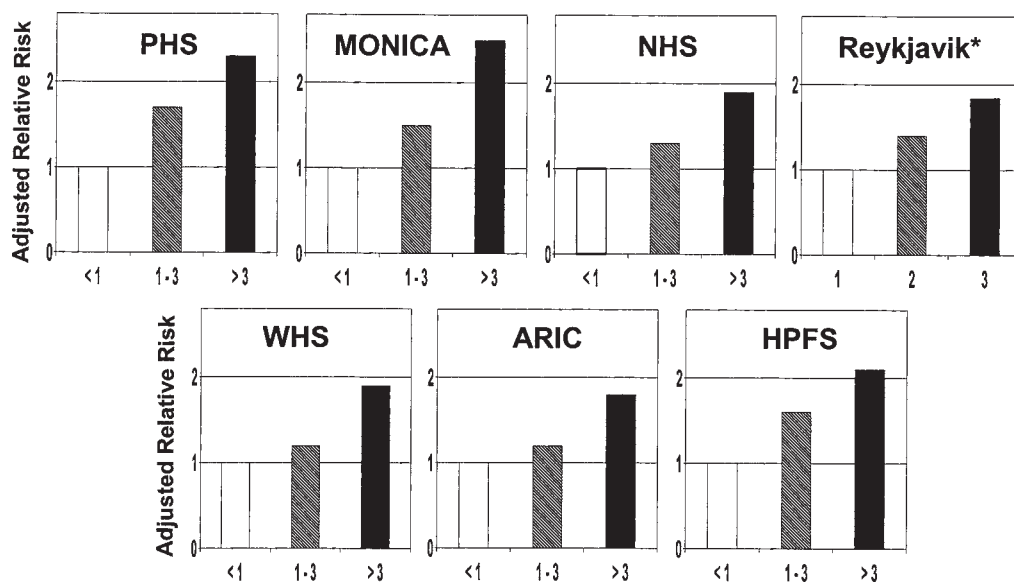


**Fig. 4.** hsCRP provides prognostic information at all levels of LDL-C and at all levels of the Framingham risk score. (Reproduced from ref. 12.)

of the National Cholesterol Education Program (68) but also at all levels of risk specified by the Framingham algorithm (12). After adjusting for all components of the Framingham risk score, the RR associated with increasing hsCRP quintiles at baseline were 1.0, 1.3, 1.4, 1.7, and 1.9 ( $p$  for trend  $<0.001$ ) for all participants, and 1.0, 1.6, 1.5, 1.8, and 2.2 ( $p$  for trend  $<0.001$ ) for those not taking postmenopausal hormone therapy. For the hsCRP cut points of  $<1$ , 1 to  $<3$ , and 3 mg/L or greater, the adjusted RRs were 1.0 (referent), 1.2 (95% CI: 0.9–1.5), and 1.5 (95% CI: 1.2–1.9) ( $p$  for trend  $<0.001$ ) for all participants, and 1.0 (referent), 1.1 (95% CI: 0.9–1.6), and 1.5 (95% CI: 1.2–1.9) ( $p$  for trend  $<0.001$ ) for those not taking postmenopausal hormone therapy (69).

The results from the Women's Health Study confirm earlier findings from a nested case–control analysis within the Physicians' Health Study, which showed that baseline levels of hsCRP were associated with incident MI and thromboembolic stroke even after control for cholesterol level in a large cohort of healthy middle-aged men followed for 14 yr (543 end points were included in the analysis) (40). More recent analyses of the Physicians' Health Study data indicate that hsCRP remains an independent predictor of MI in men after adjustment for all components of the Framingham risk score; compared with men with hsCRP levels  $<1$  mg/L, those with hsCRP levels between 1 and 3 mg/L were 70% more likely to develop MI, and those with hsCRP levels  $>3$  mg/L were more than twice as likely (RR: 2.2; 95% CI: 1.2–3.8) to do so (70).

These additive effects of hsCRP beyond the traditional Framingham risk score have also been observed in other large prospective studies. In a case–cohort analysis conducted among 12,819 apparently healthy middle-aged men and women followed for 6 yr in the multiethnic ARIC study (608 cases), the RR of incident CHD for those with baseline hsCRP levels  $<1$ , 1–3, and  $>3$  mg/L were 1.0 (referent), 1.31 (95% CI: 0.96–1.80), and 1.72 (95% CI: 1.24–2.39), respectively, after adjusting for age, sex, race, smoking status, systolic blood pressure, LDL-C, high-density lipoprotein cholesterol (HDL-C), and diabetes (21). Similar findings were obtained in a 6.6-yr follow-up of 3435 German men ages 45–74 yr participating in the MONICA Augsburg study; after adjustment for the 10-yr Framingham CHD risk score (categorized as  $<6$ , 6–10, 11–14, 15–19, and  $\geq 20\%$ ), the RR of incident



**Fig. 5.** Framingham-adjusted RRs of future coronary events according to baseline levels of hsCRP of <1, 1–3, and >3 mg/L in major cohort studies. (Data from refs. [10,12,21,39](#), and [56–58](#).) \*The Reykjavik data were reported for hsCRP tertiles rather than for hsCRP cutpoints of <1, 1–3, and >3 mg/L.

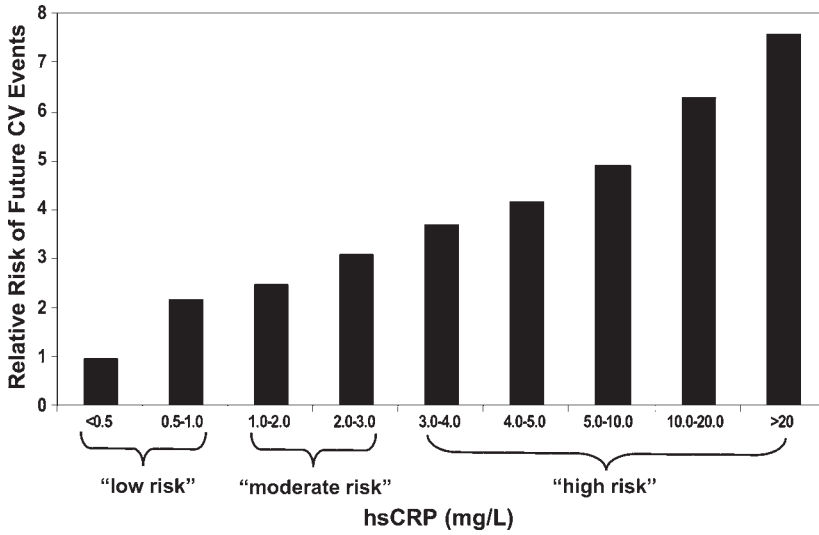
MI or sudden cardiac death among men with hsCRP levels <1, 1–3, and >3 mg/L were 1.0 (referent), 1.44 (95% CI: 0.95–2.17), and 2.21 (95% CI: 1.49–3.27), respectively ([56](#)). In subgroup analyses, the predictive utility of hsCRP was most apparent among men at intermediate coronary risk—i.e., those whose 10-yr Framingham scores were between 10 and 20%. In nested case–control analyses conducted within the large Nurses’ Health Study (32,826 initially healthy women with a baseline blood sample were followed for 8 yr, during which time 249 incident CHD cases occurred) and the Health Professionals Follow-up Study (18,225 initially healthy men with a baseline blood sample were followed for 6 yr, during which time 266 incident CHD cases occurred), the pooled RR comparing hsCRP levels of  $\geq 3$  mg/L to levels <1 mg/L was 1.46 (95% CI: 1.08–2.04) in a model that controlled for the effects of age, hypertension, ratio of total cholesterol to HDL-C, smoking, and diabetes ([58](#)). After additional adjustment for alcohol intake, body mass index (BMI), physical activity, parental history of CHD before age 60, and, for women, postmenopausal hormone therapy, the risk estimate remained largely unchanged (RR: 1.68; 95% CI: 1.18–2.38). Indeed, of recent large-scale population-based studies, only the Rotterdam Study failed to find that the addition of hsCRP to a model with classic cardiovascular risk factors improved risk prediction. In this nested case–control study conducted among 7983 Dutch men and women age 55 yr and older who were followed for 5 yr for incident MI, the age- and sex-adjusted RR for the extreme quartile comparison (hsCRP >3.02 vs <0.82 mg/L) was 2.0 (95% CI: 1.1–3.4), but the association was attenuated after additional adjustment for smoking, total cholesterol, HDL-C, hypertension, diabetes, BMI, and family history of premature MI (RR: 1.2; 95% CI: 0.6–2.2) ( $p$  for trend across quartiles <0.50) ([55](#)). Nevertheless, the consistency of the Framingham-adjusted risk estimates in the Women’s Health Study, Physicians’ Health Study, ARIC, MONICA, Nurses’ Health Study, and Health Professionals Follow-up Study provides compelling support for the incorporation of hsCRP into existing prediction algorithms ([Fig. 5](#)).

Data from a study in Reykjavik, Iceland that included 2459 incident CHD events during a 20-yr follow-up of 18,569 men and women also highlight the clinical utility of hsCRP as an independent predictor of risk even in a population with elevated lipid levels (57). In this study, baseline hsCRP levels were associated with an approximate 50% increase in future vascular risk not only after adjustment for the traditional Framingham risk factors but also after further control for triglycerides, BMI, and indices of pulmonary function (hsCRP  $\geq 2.0$  vs  $< 0.78$  mg/L; RR: 1.45; 95% CI: 1.25–1.68). During the first 10 yr of follow-up, an even higher risk was observed (RR: 1.84; 95% CI: 1.49–2.28). The reported RRs from Iceland were calculated using an hsCRP cut point of 2.0 mg/L rather than the recommended 3.0 mg/L and thus likely underestimate the predictive ability of hsCRP. Even so, the prognostic value of hsCRP in this cohort was virtually identical to that of high blood pressure and statistically similar to that of smoking.

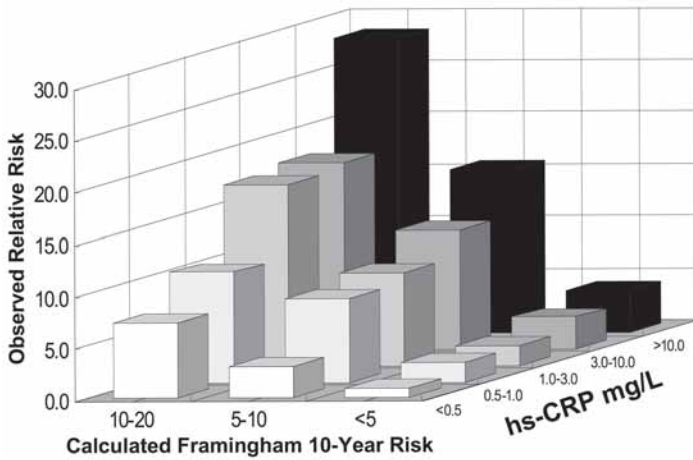
Additional data supporting the addition of hsCRP to the Framingham risk evaluation come from two primary prevention trials. Among 5742 healthy men and women enrolled in the Air Force/Texas Coronary Atherosclerosis Prevention Study (AFCAPS/TexCAPS), a primary prevention trial of lovastatin, each quartile increase in baseline hsCRP predicted a 21% increase in the risk of a first cardiovascular event (95% CI: 4–41%), an association that persisted after adjustment for all individual components of the Framingham risk score (48). In a cross-sectional survey of 1666 men and women without CVD participating in the Pravastatin Inflammation/CRP Evaluation trial, hsCRP level was minimally correlated with each variable in the 10-yr Framingham risk score and only modestly correlated with the score itself ( $r < 0.30$ ) (71).

Although the relationship between hsCRP and CHD has been more extensively studied than that between hsCRP and stroke, data from the Framingham Study suggest that hsCRP is also an independent predictor of cerebral thrombosis. Among 1462 respondents followed for 12–14 yr for the development of a first ischemic stroke or transient ischemic attack, there were significant increases in risk across hsCRP quartiles after factoring out the effects of smoking, ratio of total cholesterol to HDL-C, systolic blood pressure, and diabetes (60). Among women, the RRs associated with increasing hsCRP quartiles ( $< 1.00$ , 1.02–3.19, 3.20–7.31,  $\geq 7.33$  mg/L) were 1.0 (referent), 1.2 (95% CI: 0.63–2.27), 1.6 (95% CI: 0.89–2.93), and 2.1 (95% CI: 1.9–3.83) ( $p$  for trend = 0.008). Among men, the corresponding RRs (for hsCRP quartiles of  $< 1.08$ , 1.10–3.00, 3.03–6.80,  $\geq 6.90$  mg/L) were 1.0 (referent), 0.9 (95% CI: 0.46–1.86), 1.5 (95% CI: 0.80–2.87), and 1.6 (95% CI: 0.87–3.13) ( $p$  for trend = 0.04).

Clinical interpretation of hsCRP is most conveniently performed using cut points of  $< 1$ , 1–3, and  $> 3$  mg/L. However, recent findings from the Women's Health Study suggest that the cardiovascular risk gradient extends across the full range of hsCRP levels. That is, the absolute risk of CVD is extremely low for those 10–15% of individuals with hsCRP levels  $< 0.5$  mg/L, and, by contrast, the risk is extremely high when hsCRP levels exceed 10 mg/L (Fig. 6) (69). Moreover, as shown in Fig. 7, there is a clear risk gradient associated with a five-tier classification scheme for hsCRP ( $< 0.5$ , 0.5 to  $< 1$ , 1 to  $< 3$ , 3 to  $< 10$ , and  $\geq 10$  mg/L) across all levels of the Framingham risk score (70). A monotonic increase in cardiovascular risk associated with rising hsCRP levels was observed not only among individuals with estimated 10-yr Framingham risk scores of between 10 and 20% but also among those with lower scores. These data suggest that an hsCRP-modified Framingham risk score could improve the prediction of CHD events in general population settings.



**Fig. 6.** Clinical predictive value for future cardiovascular (CV) events of very low (<0.5 mg/L) and very high (>10 mg/L) levels of hsCRP. (Reproduced from ref. 69.)



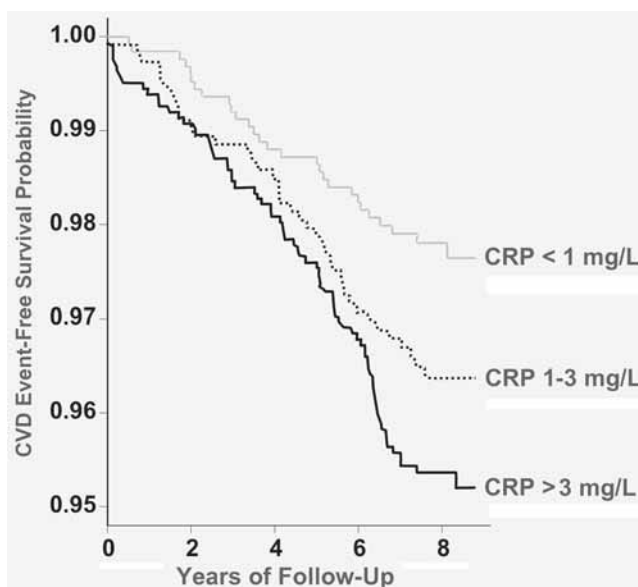
**Fig. 7.** RRs of future coronary events according to a five-category classification scheme for hsCRP and Framingham risk score. (Reproduced from ref. 70.)

It should be noted that most of the epidemiological studies cited were conducted in white populations of predominantly European ancestry. With some exceptions (e.g., the aforementioned Honolulu Heart Program [53,61]), few data on the utility of hsCRP as a predictor of incident CVD in nonwhite cohorts exist. Additional investigations in racially diverse populations are needed.

***hsCRP, Metabolic Syndrome, and Type 2 Diabetes Mellitus***

Another reason for clinical interest in adding hsCRP to current risk algorithms derives from the fact that inflammation may play a key role in processes associated with metabolic syndrome, a condition that confers increased cardiovascular risk (72). hsCRP levels are correlated positively with components of metabolic syndrome commonly measured in





**Fig. 8.** Cardiovascular event-free survival according to baseline level of hsCRP among individuals with metabolic syndrome. (Adapted from ref. 75.)

clinical practice, such as elevated triglycerides, low HDL-C, obesity, high fasting glucose, and high blood pressure (BP). In the Women's Health Study, e.g., after adjustment for multiple potential confounders, the RRs of incident hypertension for increasing hsCRP quintiles were 1.00 (referent), 1.07 (95% CI: 0.95–1.20), 1.17 (95% CI: 1.04–1.31), 1.30 (95% CI: 1.17–1.45), and 1.52 (95% CI: 1.36–1.69), respectively ( $p$  for trend of  $<0.001$ ) (73). hsCRP levels are also correlated with other components of the syndrome not easily assessed during routine office visits, such as fasting insulin, microalbuminuria, and impaired fibrinolysis. Indeed, among Women's Health Study participants without diabetes, hsCRP and BMI were the only independent correlates of fasting insulin level modeled as a continuous dependent variable. After adjustment for BMI and other risk factors for diabetes, the RR for elevated fasting insulin ( $\oplus 51.6$  pmol/L) increased with the tertile of hsCRP (for hsCRP  $<1.4$ ,  $1.4$ – $4.4$ , and  $\oplus 4.4$  mg/L, RRs were 1.0, 3.7, and 4.4, respectively;  $p$  for trend  $<0.001$ ) (74). This association was observed among both lean and overweight women.

Data from the Women's Health Study also show that hsCRP levels  $<1$ ,  $1$ – $3$ , and  $>3$  mg/L successfully differentiated women with metabolic syndrome into low-, moderate-, and high-risk groups (Fig. 8) (75). In analyses comparing the predictive ability of hsCRP alone ( $\oplus 3$  vs  $<3$  mg/L) with that of metabolic syndrome alone, the area under the receiver operating characteristic curve was 0.77 for hsCRP and 0.78 for metabolic syndrome, indicating that the two variables are equally useful for cardiovascular risk assessment. However, as with LDL-C and the Framingham risk score, the addition of hsCRP to the traditional metabolic syndrome definition provided the best predictive algorithm. Similar results were observed in a cohort of 6447 middle-aged men followed for 5 yr in the West of Scotland Coronary Prevention Study (76). hsCRP, coded as  $\oplus 3$  vs  $<3$  mg/L, was predictive of inci-

dent CHD after stratification by metabolic syndrome status. Among participants in the “low-CRP/metabolic syndrome absent,” “high-CRP/metabolic syndrome absent,” “low-CRP/metabolic syndrome present,” and “high-CRP/metabolic syndrome present” groups, the RRs for incident CHD were 1.0 (referent), 1.6 (95% CI: 1.3–2.1), 1.6 (95% CI: 1.2–2.1), and 2.75 (95% CI: 2.1–3.6), respectively. In a 7-yr follow-up of 3037 men and women without diabetes in the Framingham Offspring Study, persons in the highest quartile of hsCRP had nearly twice the risk of developing CVD than did those in the lowest quartile after adjustment for age, sex, and the presence of the metabolic syndrome (hsCRP  $\geq$ 4.5 vs  $<$ 0.25 mg/L; RR: 1.9; 95% CI: 1.2–2.9) (77). hsCRP levels have additionally been found to predict cardiovascular risk among persons with diabetes. Among 746 men with diabetes followed for 5 yr in the Health Professionals Follow-up Study, those in the top quartile of hsCRP were nearly three times more likely to develop cardiovascular events than those in the bottom quartile after adjustment for traditional risk factors, including blood lipids, as well as fibrinogen, creatinine, and glycosylated hemoglobin (RR: 2.62; 95% CI: 1.29–5.32) (median hsCRP levels in the top and bottom quartiles were 4.86 and 0.53 mg/L, respectively) (78).

Prospective studies have also found strong monotonic relationships between hsCRP and incident diabetes, often after adjustment for BMI and other risk factors for diabetes. In the West of Scotland Coronary Prevention Study, the top quintile of hsCRP was associated with a threefold increase in the incident diabetes rate (hsCRP  $>$ 4.18 vs  $\leq$ 0.66 mg/L; multivariable-adjusted 5-yr RR: 3.07; 95% CI: 1.33–7.10) (79), and hsCRP remained significantly predictive after stratification by metabolic syndrome status. Among men in the “low-CRP/metabolic syndrome absent,” “high-CRP/metabolic syndrome absent,” “low-CRP/metabolic syndrome present,” and “high-CRP/metabolic syndrome present” groups, the RRs for incident diabetes were 1.0 (referent), 1.8 (95% CI: 1.1–3.0), 3.6 (95% CI: 2.3–5.6), and 5.3 (95% CI: 3.3–8.3), respectively (76). In the Women’s Health Study, women in the top quartile of the hsCRP distribution were more than four times as likely to develop diabetes than women in the bottom quartile during 4 yr of follow-up (hsCRP  $>$ 6.1 vs  $<$ 1 mg/L; multivariable-adjusted RR: 4.2; 95% CI: 1.2–12) (80). Similarly, in the Nurses’ Health Study, the extreme quintile comparison (hsCRP  $\geq$ 4.05 vs  $\leq$ 0.55 mg/L) yielded a multivariable-adjusted RR of 4.36 (95% CI: 2.80–6.80) over 10 yr of follow-up (81). Among 5888 persons age 65 yr or older in the Cardiovascular Health Study, a comparison of the extreme hsCRP quartiles revealed a near doubling of risk over 4 yr (hsCRP  $>$ 2.86 mg/L vs  $<$ 0.82 mg/L; multivariable-adjusted RR: 1.83; 95% CI: 1.24–2.86) (82). By contrast, despite strong age-adjusted associations between hsCRP and incident diabetes in the 7-yr MONICA Augsburg study of 2052 middle-aged men (83) and the 5-yr Insulin Resistance Atherosclerosis Study (84) of 1047 middle-aged men and women, hsCRP was not predictive of diabetes in these cohorts after factoring out the effect of BMI. Nevertheless, in the aggregate, these data support the hypothesis that inflammation, atherothrombosis, and diabetes are closely related disorders of the innate immune system.

### ***hsCRP, Renal Disease, and Cardiovascular Risk***

Chronic renal failure is a risk factor for cardiovascular morbidity and mortality. Clinic-based studies have found that hsCRP levels of hemodialysis patients are 8 to 10 times higher than those of healthy control subjects. Population-based studies also report strong correlations between renal dysfunction and hsCRP. In the large National Health and Nutrition Examination Survey, respondents with elevated hsCRP levels were more likely to have

impaired kidney function (an estimated glomerular filtration rate of  $<60$  mL/min per  $1.73$  m<sup>3</sup>) than respondents with lower hsCRP levels (CRP of  $\oplus 10$  vs  $<2.2$  mg/L; RR: 2.20; 95% CI: 1.54–3.15) (85). hsCRP levels predict CVD mortality in hemodialysis patients. In a 4-yr follow-up of 280 stable dialysis patients with baseline hsCRP quartiles of  $<3.3$ , 3.3–7.4, 7.5–15.8, and  $\oplus 15.8$  mg/L, there was a strong dose–response relationship between hsCRP quartile and cardiovascular death, with a RR of 1.7 for the extreme-quartile comparison ( $p < 0.0001$ ) (86). Although results from ongoing randomized trials targeting inflammation in patients with renal failure are not yet available, implementing aggressive CVD prevention programs in those with elevated hsCRP levels may be advisable.

### *hsCRP and Subclinical Atherosclerosis*

In contrast to the consistent findings on the relationship between hsCRP and incident cardiovascular events, evidence for an association between hsCRP and measures of subclinical atherosclerosis has been mixed. Among 3173 persons in the Framingham Offspring Study, a comparison of the top vs bottom quartile of hsCRP (measured 4 yr prior to carotid ultrasonography) yielded an age-adjusted RR of carotid stenosis ( $\oplus 25\%$ ) of 3.90 (95% CI: 2.44–6.44) in women and 1.62 (95% CI: 1.12–2.36) in men (87). After factoring out the effects of BMI and other cardiovascular risk factors, the relation remained in women (RR: 2.97; 95% CI: 1.72–5.25) but not men (RR: 1.07; 95% CI: 0.71–1.61). Similar results were observed when the analyses were limited to participants without prevalent CVD, and when measures of internal, but not common, carotid intimal-medial thickness (IMT) were used. hsCRP level was also positively correlated with the extent of coronary artery calcification 4–8 yr later in a subsample of 321 healthy individuals who were evaluated with electron beam computerized tomography (EBCT); in contrast to the Doppler findings regarding stenosis, the correlation persisted in men but not women after adjustment for Framingham risk score and BMI (88). Among 1317 men and women in the Rotterdam Study, there was a strong positive association between hsCRP and common carotid IMT (89); persons with hsCRP levels in the top tertile of the sample distribution were twice as likely to have moderate or severe carotid plaques as were persons in the bottom tertile ( $>2.77$  vs  $\leq 1.11$  mg/L; RR: 2.0; 95% CI: 1.3–3.0) after adjustment for BMI and other covariates (analyses stratified by gender were not provided). An inverse association between hsCRP and the ankle-brachial index was also observed. Among 502 patients with coronary artery disease assigned to atorvastatin or pravastatin for 18 mo in the Reversal of Atherosclerosis with Aggressive Lipid Lowering trial, the magnitude of change in hsCRP and the magnitude of change in LDL-C were both independent predictors of coronary plaque regression as measured by intravascular ultrasound (90). On the other hand, in a subsample of 590 men and women in the ARIC study, there was no independent association between hsCRP and prevalent atherosclerosis, as defined by an average carotid IMT (i.e., the mean of the average IMT of the bilateral common carotid, internal carotid, and bifurcation) of at least 0.93 mm (51). Moreover, the National Heart, Lung, and Blood Institute Family Heart Study, a collective analysis of selected members of four population-based cohorts, including Framingham and ARIC, found a weak inverse association between hsCRP and the ankle-brachial index only in men (91). Other studies also suggest that correlations between hsCRP and coronary calcification are low. For example, among 914 asymptomatic participants in the Study of Inherited Risk of Coronary Atherosclerosis, hsCRP was not associated with coronary artery calcification in men, and a weak relationship disappeared after adjustment for BMI in women (92).

On the basis of these findings, some investigators have postulated that elevated hsCRP levels primarily reflect an increased tendency for plaque rupture, rather than a high atherosclerotic burden. In support of this hypothesis, autopsy studies show that elevated hsCRP is associated with increased macrophage density in plaque, a higher prevalence of thin-cap atheromas, and increased risk of plaque erosions and rupture (93). Epidemiological studies also lend credence to this idea; in a 10-yr follow-up of 5417 elderly participants in the Cardiovascular Health Study without a history of stroke or atrial fibrillation at baseline, elevated hsCRP was associated with incident ischemic stroke independent of the severity of atherosclerosis as measured by the average of the maximal common and internal carotid IMT (62). Notably, the relation between hsCRP and stroke was strongest in participants with greater carotid stenosis. In a 2.4-yr follow-up of the same cohort, there was also a more pronounced association between hsCRP and incident MI among participants with evidence of subclinical disease than among those without such evidence, although this difference was observed only in women (43). On the other hand, in the younger ARIC cohort, carotid IMT did not influence the relationship between hsCRP and incident CHD (51).

### *hsCRP in Secondary Prevention Settings*

hsCRP is predictive of recurrent vascular events and death among patients with ACS and stroke (6). Elevated preprocedural hsCRP levels also portend a worse prognosis for patients undergoing percutaneous transluminal coronary angioplasty, coronary artery bypass grafting, and coronary artery stenting (6). The role of hsCRP in risk assessment in acute coronary settings is the topic of Chapter 17. This section reviews studies of the predictive utility of hsCRP measurement in stable patients with a history of MI.

There is growing evidence that hsCRP predicts adverse events in the stable phase after MI. In the Cholesterol and Recurrent Events (CARE) secondary prevention trial of pravastatin, patients with elevated hsCRP levels at 3–20 mo following an index MI were at higher risk of recurrent events during 5 yr of follow-up (94). A Norwegian study of 247 patients with premature MI also found that hsCRP was associated with future coronary death (95). In that cohort, the 10-yr RR of cardiac mortality doubled with increasing hsCRP quartiles (<1.20, 1.20–2.37, 2.37–4.20,  $\geq$ 4.20 mg/L); patients in the top quartile had six times the risk of cardiac death as did those in the bottom quartile. Adjustment for age, left ventricular ejection fraction, serum total cholesterol, fibrinogen, hypertension, and smoking attenuated but did not eliminate the association. In the multinational Pravastatin or Atorvastatin Evaluation and Infection Therapy—Thrombolysis in Myocardial Infarction 22 (PROVE-IT) trial of intensive (atorvastatin, 80 mg/d) vs moderate (pravastatin, 40 mg/d) statin therapy among 3745 patients with recent MI or unstable angina, the hsCRP level achieved at 30 d after enrollment was strongly predictive of the risk of recurrent coronary events during 2 yr of follow-up; after controlling for the LDL-C level achieved at 30 d and other covariates such as smoking, hypertension, diabetes, and BMI, patients in the highest hsCRP quartile were 70% more likely to experience a recurrent event than those in the lowest quartile (RR: 1.7; 95% CI: 1.1–2.5) (96). The THROMBOgenic risk factor study found that hsCRP levels measured 2 mo after an index MI significantly predicted the 2-yr risk of recurrent coronary events in a cohort of 1045 patients, although the association did not persist after adjustment for ejection fraction and the presence of pulmonary congestion (97). Nevertheless, these data, taken as a whole, indicate that hsCRP can improve risk prediction in secondary prevention settings.

## PRACTICAL CONSIDERATIONS

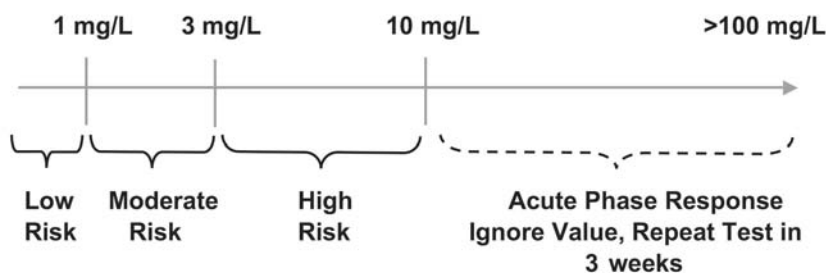
CRP has long been measured in clinical laboratories to monitor active infection. Traditional assays for CRP have a lower detection limit of 3–8 mg/L and, thus, are not sensitive enough to detect the low-end variations required for prediction of cardiovascular risk. High-sensitivity assays that overcome this limitation are now commercially available.

Although it is an acute-phase reactant, CRP exhibits a relatively low degree of intraindividual variability in clinically stable patients. Whether serial assessment of hsCRP provides incremental clinical benefit is uncertain. Consistent with cholesterol-screening guidelines, the Centers for Disease Control (CDC) and the American Heart Association (AHA) recommend the use of two hsCRP measures taken at least 2 wk apart with the average value used to estimate vascular risk (9). However, many physicians believe that a single measure is sufficient provided that a value of <10 mg/L is obtained. Because CRP levels increase sharply in response to major infections, trauma, or other acute conditions, levels above 10 mg/L should initially be disregarded and the test should be repeated when the patient has stabilized. If an elevated CRP level persists, especially in the presence of a high erythrocyte sedimentation rate, alternative sources of systemic inflammation such as rheumatoid arthritis, inflammatory bowel disease, or endocarditis should be considered. Nevertheless, recent analyses from the Women's Health Study suggest that chronically elevated CRP levels may indicate exceptionally high coronary risk (69).

CRP has other characteristics in addition to its relatively low long-term biological variability that render it suitable for use in clinical practice. CRP levels are not affected by food intake and exhibit little circadian variation. Thus, measurements can be made without regard for fasting status or time of day. CRP has a long plasma half-life of between 18 and 20 h, allowing accurate readings in fresh or frozen blood without the need for special collection procedures. Elevated CRP levels within the range detected by high-sensitivity assays have demonstrated specificity for vascular events. In the Women's Health Study, baseline hsCRP levels were not associated with the incidence of cancer (42). Similarly, in the Study of Osteoporotic Fractures, a population-based cohort of women age 65 yr and older, an elevated hsCRP level predicted cardiovascular mortality (hsCRP >3 vs ≤3 mg/L; adjusted RR: 8.0; 95% CI: 2.2–2.9) but was unrelated to mortality from noncardiovascular causes (RR: 0.92; 95% CI: 0.4–2.1) during 6 yr of follow-up (98).

Population norms for hsCRP are available, and there are currently no compelling data to support the use of gender-, age-, or race-specific guidelines, thus simplifying the application of clinical cut points. Ranges of <1, 1–3, and >3 mg/L, which correspond to approximate tertiles of the hsCRP distribution in healthy US adults, are recommended for classification of individuals into lower-, moderate-, and higher-cardiovascular-risk groups in primary prevention (Fig. 9) (9,99). However, although this simple trichotomy is useful for primary care practice, it should be recognized that patients with the lowest hsCRP levels (<0.5 mg/L) are at very low cardiovascular risk and those with persistent marked elevations in hsCRP (>10 mg/L) are at very high risk (69).

The cost of hsCRP screening is comparable with that of standard cholesterol evaluation and is less than that of alternative screening approaches such as EBCT or magnetic resonance imaging. hsCRP screening appears to yield tangible benefits in terms of years of life saved and cost-to-benefit ratios (100). For these reasons, the inclusion of hsCRP testing in routine physical examinations is gaining popularity.



**Fig. 9.** Clinical application of hsCRP levels for cardiovascular screening: levels of hsCRP of <1, 1–3, and >3 mg/L correspond to low-, moderate-, and high-risk groups. (Reproduced from ref. [125](#).)

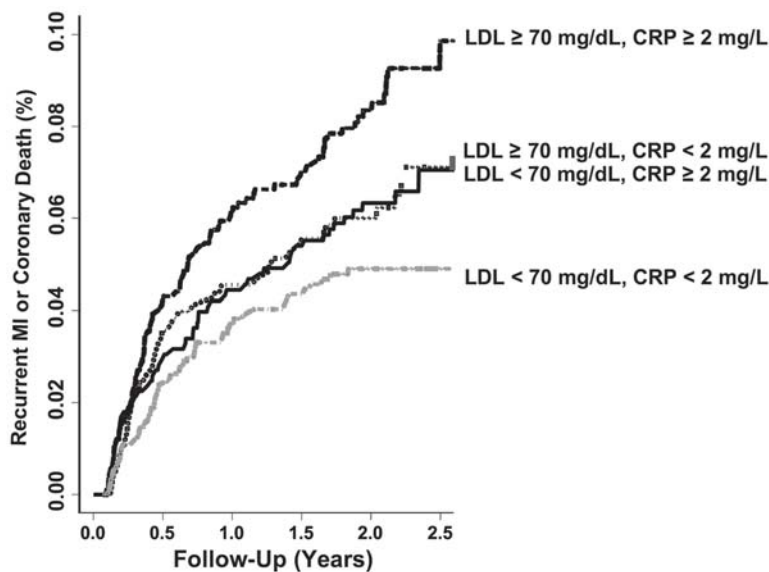
## THERAPEUTIC INTERVENTIONS

Conclusive evidence that lowering hsCRP levels leads to a reduction in clinical cardiovascular events in primary prevention settings is not available. Nevertheless, many behavioral and pharmacological interventions that reduce cardiovascular event rates are associated with lower hsCRP levels. Behavioral interventions in this category include smoking cessation, weight loss, increased physical activity, and dietary modification (*see* ref. [6](#) for a review). Pharmacological interventions are reviewed in the following sections. Because a patient's compliance with recommended interventions depends in part on his or her perception of absolute disease risk and because the addition of hsCRP testing to existing risk algorithms provides an improved prediction tool, a major rationale for hsCRP screening is to help motivate at-risk individuals to adopt healthier lifestyles and to comply with prescribed drug therapies.

### Statins

The ability of statins to lower hsCRP was first described for pravastatin using data from the CARE trial ([94,101](#)). Subsequent confirmatory work has shown the effect of statins on hsCRP to be an important class effect. A meta-analysis of the effects of statins on nonlipid serum markers—specifically CRP, fibrinogen, homocysteine, LDL-C oxidation, tissue plasminogen activator, plasminogen activator inhibitor, and platelet aggregation—concluded that, of these, only CRP appears to be influenced by statin use ([102](#)). Indeed, studies of pravastatin, lovastatin, cerivastatin, simvastatin, and atorvastatin indicate that, on average, median hsCRP levels decline 15–25% as early as 6 wk following initiation of therapy ([102](#)) in persons with no history of CVD ([48,103–106](#)) and in patients with stable coronary disease ([103,107](#)) or ACS ([90,108](#)). Ezetimibe, a novel cholesterol absorption inhibitor that prevents absorption of dietary and biliary cholesterol without affecting that of triglycerides and fat-soluble vitamins, appears to augment the CRP-lowering ability of statins ([106,109](#)).

More important, the magnitude of hsCRP cholesterol reduction owing to statin therapy is minimally correlated with the magnitude of reduction in LDL-C ([102](#)). Although statins reduce LDL-C levels in virtually all patients, there is wide variation in hsCRP response. Recent research suggests that this variation is important in predicting clinical cardiovascular outcomes, at least in secondary prevention settings. In the PROVE-IT trial of intensive (atorvastatin, 80 mg/d) vs moderate (pravastatin, 40 mg/d) statin therapy, patients who achieved an LDL-C level lower than the sample median of 70 mg/dL after 30 d of treatment were less likely to experience a recurrent coronary event than those who did not achieve this level (2.7 vs 4.0 events per 100 person-yr;  $p = 0.008$ ) ([96](#)). A virtually identical rate



**Fig. 10.** Cumulative rates of recurrent MI or cardiovascular death following initiation of statin therapy among patients with ACS, according to achieved levels of LDL-C and of hsCRP. (Reproduced from ref. 96.)

difference was observed for a parallel median-split analysis of hsCRP levels: participants who achieved an hsCRP level of  $<2.0$  mg/L after 30 d of treatment were less likely to have a recurrent event than those who did not achieve this goal (2.8 vs 3.9 events per 100 person-yr;  $p = 0.006$ ). The relation between achieved hsCRP and recurrent events was observed at all levels of achieved LDL-C. Among participants with LDL-C levels  $\geq 70$  mg/dL, the event rates associated with hsCRP levels below and above 2.0 mg/L were 3.2 and 4.6 per 100 person-yr, respectively, and the corresponding rates among participants with LDL-C levels  $<70$  mg/dL were 2.4 and 3.1 events per 100 person-yr ( $p < 0.001$ ). Thus, measuring both achieved LDL-C and achieved hsCRP improves risk prediction (Fig. 10). Moreover, although atorvastatin was more effective than pravastatin in reducing LDL-C and hsCRP, there was no residual effect of choice of treatment on cardiovascular event-free survival after factoring out the effects of achieved levels of LDL-C and hsCRP, which suggests that measuring both biomarkers is not only necessary but also sufficient to assess the comparative efficacy of a statin drug in reducing cardiovascular risk for a given individual. More generally, the results of PROVE-IT suggest that the implementation of risk reduction strategies should include an inflammation as well as a cholesterol-monitoring component to assess whether the chosen strategy has a reasonable chance of preventing a recurrent event.

The PROVE-IT results extend findings from two earlier randomized trials indicating that the cardiovascular risk reduction attributable to statin therapy may be most marked for those with elevated hsCRP levels at baseline. In the 5-yr CARE trial, the proportion of recurrent events prevented by pravastatin was 54% among persons with elevated hsCRP levels but only 25% among persons with lower hsCRP levels, even though baseline lipid levels were similar in those with and without evidence of inflammation (94). Similarly, in a post hoc analysis of data from the AFCAPS/TexCAPS primary prevention trial, lovastatin therapy was associated with a 42% reduction in first cardiovascular events

Table 1  
Five-Year RRs of Acute Coronary Events and Number Needed  
to Treat (NNT) According to Baseline Levels of LDL-C and hsCRP, AFCAPS/TexCAPS<sup>a</sup>

Study group	Lovastatin		Placebo		RR	95% CI	NNT <sup>b</sup>
	n	Rate	n	Rate			
Low LDL-C/low hsCRP	19/726	0.025	17/722	0.022	1.08	0.56–2.08	—
Low LDL-C/high hsCRP	22/718	0.029	37/710	0.051	0.58	0.34–0.98	48
High LDL-C/low hsCRP	15/709	0.020	37/711	0.050	0.38	0.21–0.70	33
High LDL-C/high hsCRP	29/741	0.038	40/705	0.055	0.68	0.42–1.10	58

<sup>a</sup>Data are derived from ref. 48.

<sup>b</sup>NNT indicates the number needed to treat to prevent one coronary event. NNT cannot be calculated for the low-LDL-C/low-hsCRP group because there was no evidence of efficacy of lovastatin in this group.

(RR: 0.58; 95% CI: 0.34–0.98) over a 5-yr period among participants with low LDL-C levels (<149 mg/dL) but high hsCRP levels (>1.6 mg/L) (Table 1) (48). Taken in conjunction with epidemiological findings that high hsCRP is associated with an increased risk of first cardiovascular events even in the absence of elevated LDL-C, these results highlight the need for a clinical trial to test the efficacy of statins in reducing cardiovascular events among individuals with the high hsCRP/low LDL-C phenotype, who comprise an estimated 25% of the U.S. adult population. Such a trial is under way; the Justification for the Use of Statins in Primary Prevention: An Intervention Trial Evaluating Rosuvastatin will randomize approx 15,000 persons with hsCRP levels >2 mg/L and LDL-C levels <130 mg/dL to rosuvastatin or placebo and follow them for 3 to 4 yr to determine whether the drug reduces the incidence of first vascular events (110).

### Aspirin and Other Antiplatelet Agents

The ability of antiplatelet therapy to prevent future cardiovascular events appears to vary by hsCRP level. In the Physicians' Health Study, a large primary prevention trial, the reduction in risk of future MI associated with assignment to aspirin (325 mg on alternate days) was 56% ( $p = 0.02$ ) among participants with baseline hsCRP levels in the highest quartile and declined with hsCRP levels such that a reduction of only 14% ( $p = 0.80$ ) was observed among those in the lowest quartile, suggesting that aspirin may prevent ischemic events through anti-inflammatory as well as antiplatelet effects (39). Similarly, observational data indicate that the beneficial effects of clopidogrel and abciximab may be greatest in patients with elevated CRP levels prior to percutaneous coronary interventions (111–113). On the other hand, ticlopidine was associated with a significant risk reduction in subsequent cardiovascular events among ischemic stroke patients with admission hsCRP levels in the bottom two tertiles of the sample distribution, whereas a nonsignificant excess risk was apparent among those in the highest tertile (114).

Despite the findings from the Physicians' Health Study, it is unclear whether aspirin or other antiplatelet agents can directly reduce CRP levels. Although one small trial found that 6 wk of aspirin therapy (300 mg/d) was associated with a significant reduction in hsCRP levels in patients with chronic stable angina (115), other trials, including our own unpublished study, observed no short-term effect of aspirin in doses ranging from 32 to 325 mg/d on hsCRP levels in healthy individuals (116,117).



### *Antihyperglycemic Agents*

Given the interrelationship among inflammation, metabolic syndrome, and diabetes, it is not surprising that antihyperglycemic agents such as metformin and thiazolidinedione have been shown to lower hsCRP levels. In a 26-wk trial among patients with type 2 diabetes, rosiglitazone therapy reduced hsCRP levels and other inflammatory markers (118). Changes in hsCRP level were uncorrelated with changes in glycemic control, as measured by hemoglobin A1c ( $r = 0.06$ ) and fasting glucose level ( $r = 0.06$ ) and were only minimally correlated with changes in insulin resistance ( $r = 0.13$ ). Whether the ability of such agents to lower hsCRP has clinical relevance beyond improvements in glycemic control is a focus of current research.

### *Antihypertensive Agents*

The Women's Health Study found a strong association between hsCRP and incident hypertension at all levels of baseline BP (73). Whether or not BP reduction leads to decreased levels of hsCRP is being tested in the ongoing Valsartan—Managing Blood Pressure Aggressively and Evaluating Reduction in CRP (Val-MARC) clinical trial, an evaluation of the effects of valsartan on hsCRP in patients with stage II hypertension.

### *Avoidance of Postmenopausal Hormone Therapy*

hsCRP levels are higher in women who take oral postmenopausal hormones than in women who do not (12,52,71,119,120), suggesting that elevated hsCRP levels may account in part for the increased risk of thrombotic events associated with the use of oral postmenopausal hormones in randomized trials such as the Women's Health Initiative (121,122). Indeed, among participants in the observational component of that study, CHD incidence rates at any given level of hsCRP were similar for users and nonusers of postmenopausal hormones, suggesting that expressed level of hsCRP rather than hormone use *per se* is the proximate determinant of risk (52). More research is needed to determine the clinical relevance of apparently sustained reductions (or elevations) in hsCRP levels after discontinuation (or initiation) of postmenopausal hormone therapy. Selective estrogen receptor modulators, which have not been implicated in the development of CVD, do not raise hsCRP levels (123), nor do transvaginal or transdermal estrogens (124). Thus, the adverse effects of oral postmenopausal hormone therapy may be owing in part to first-pass hepatic processing.

## CLINICAL RECOMMENDATIONS

The CDC and the AHA endorse a conservative approach to hsCRP screening in primary prevention settings, recommending hsCRP evaluation only for patients deemed to be at intermediate cardiovascular risk on the basis of traditional risk factors—e.g., those with a 10-yr Framingham risk score of 5–20% (9). However, given accumulating epidemiological data demonstrating the predictive utility of hsCRP at all levels of the Framingham risk score and in the presence or absence of metabolic syndrome, we believe that hsCRP and lipid testing should occur concurrently to facilitate the use of the joint results for risk assessment (99). For individuals at high risk by traditional measures, an elevated hsCRP level should provide additional impetus to initiate or improve compliance with pharmacological and behavioral therapies recommended by the National Cholesterol Education Program. Similarly, for persons at low risk of CVD by traditional measures, a high hsCRP level should highlight the need to adopt health-promoting behaviors. Moreover, because

hsCRP levels are strongly correlated with metabolic syndrome and incident diabetes, physicians may wish to obtain a fasting glucose level when hsCRP levels are elevated and other risk factors for diabetes are present. As this book goes to press, the National Cholesterol Education Program is considering whether to incorporate hsCRP into established cardiovascular prediction algorithms, and the American Diabetes Association is debating whether to add hsCRP to its definition of metabolic syndrome.

hsCRP screening may also be useful in secondary prevention. Findings from the PROVE-IT trial suggest that for stable patients with a history of MI the measurement of both LDL-C and hsCRP provides an improved means of assessing the likely efficacy of statin drugs beyond that of LDL-C evaluation alone.

The availability of an accurate and inexpensive method to measure inflammation in clinical settings reflects the successful translation of novel concepts in vascular biology from “bench to bedside.” Apparently healthy patients with elevated levels of hsCRP should be counseled to shed excess weight, increase physical activity, quit smoking, avoid postmenopausal hormone therapy, and confer with their physicians regarding the use of statins and aspirin. Additional anti-inflammatory therapies that directly target the vascular endothelium may become available in the future. Although their development presents significant pharmaceutical challenges, such therapies hold great potential for ameliorating cardiovascular mortality and morbidity.

## ACKNOWLEDGMENTS

This work was supported by grants HL43851, HL63293, and HL58755 from the National Heart, Lung, and Blood Institute (Bethesda, MD); the Leducq Foundation (Paris); a Distinguished Clinical Scientist Award from the Doris Duke Charitable Foundation (New York); and the Donald W. Reynolds Foundation (Las Vegas, NV). Dr. Ridker is listed as a co-inventor on patents held by the Brigham and Women’s Hospital that relate to the use of inflammatory biomarkers in cardiovascular disease.

## REFERENCES

1. Wilson PW, D’Agostino RB, Levy D, Belanger AM, Silbershatz H, Kannel WB. Prediction of coronary heart disease using risk factor categories. *Circulation* 1998;97:1837–1847.
2. Khot UN, Khot MB, Bajzer CT, et al. Prevalence of conventional risk factors in patients with coronary heart disease. *JAMA* 2003;290:898–904.
3. Greenland P, Knoll MD, Stamler J, et al. Major risk factors as antecedents of fatal and nonfatal coronary heart disease events. *JAMA* 2003;290:891–897.
4. Ridker PM. Evaluating novel cardiovascular risk factors: can we better predict heart attacks? *Ann Intern Med* 1999;130:933–937.
5. Hackam DG, Anand SS. Emerging risk factors for atherosclerotic vascular disease: a critical review of the evidence. *JAMA* 2003;290:932–940.
6. Bassuk SS, Rifai N, Ridker PM. High-sensitivity C-reactive protein: clinical importance. *Curr Probl Cardiol* 2004;29:439–493.
7. Blake GJ, Ridker PM. Novel clinical markers of vascular wall inflammation. *Circ Res* 2001;89:763–771.
8. Blake GJ, Ridker PM. Inflammatory bio-markers and cardiovascular risk prediction. *J Intern Med* 2002; 252:283–294.
9. Pearson TA, Mensah GA, Alexander RW, et al. Markers of inflammation and cardiovascular disease: application to clinical and public health practice. A statement for healthcare professionals from the Centers for Disease Control and Prevention and the American Heart Association. *Circulation* 2003;107: 499–511.
10. Ridker PM, Hennekens CH, Buring JE, Rifai N. C-reactive protein and other markers of inflammation in the prediction of cardiovascular disease in women. *N Engl J Med* 2000;342:836–843.

11. Ridker PM, Stampfer MJ, Rifai N. Novel risk factors for systemic atherosclerosis: a comparison of C-reactive protein, fibrinogen, homocysteine, lipoprotein(a), and standard cholesterol screening as predictors of peripheral arterial disease. *JAMA* 2001;285:2481–2485.
12. Ridker PM, Rifai N, Rose L, Buring JE, Cook NR. Comparison of C-reactive protein and low-density lipoprotein cholesterol levels in the prediction of first cardiovascular events. *N Engl J Med* 2002;347:1557–1565.
13. Ridker PM, Rifai N, Stampfer MJ, Hennekens CH. Plasma concentration of interleukin-6 and the risk of future myocardial infarction among apparently healthy men. *Circulation* 2000;101:1767–1772.
14. Ridker PM, Rifai N, Pfeffer M, Sacks F, Lepage S, Braunwald E. Elevation of tumor necrosis factor- $\alpha$  and increased risk of recurrent coronary events after myocardial infarction. *Circulation* 2000;101:2149–2153.
15. Ridker PM, Hennekens CH, Roitman-Johnson B, Stampfer MJ, Allen J. Plasma concentration of soluble intercellular adhesion molecule 1 and risks of future myocardial infarction in apparently healthy men. *Lancet* 1998;351:88–92.
16. Pradhan AD, Rifai N, Ridker PM. Soluble intercellular adhesion molecule-1, soluble vascular adhesion molecule-1, and the development of symptomatic peripheral arterial disease in men. *Circulation* 2002;106:820–825.
17. Ridker PM, Buring JE, Rifai N. Soluble P-selectin and the risk of future cardiovascular events. *Circulation* 2001;103:491–495.
18. Schonbeck U, Varo N, Libby P, Buring J, Ridker PM. Soluble CD40L and cardiovascular risk in women. *Circulation* 2001;104:2266–2268.
19. Brown DA, Breit SN, Buring J, et al. Concentration in plasma of macrophage inhibitory cytokine-1 and risk of cardiovascular events in women: a nested case-control study. *Lancet* 2002;359:2159–2163.
20. Packard CJ, O'Reilly DS, Caslake MJ, et al. Lipoprotein-associated phospholipase A2 as an independent predictor of coronary heart disease. West of Scotland Coronary Prevention Study Group. *N Engl J Med* 2000;343:1148–1155.
21. Ballantyne CM, Hoogeveen RC, Bang H, et al. Lipoprotein-associated phospholipase A2, high-sensitivity C-reactive protein, and risk for incident coronary heart disease in middle-aged men and women in the Atherosclerosis Risk in Communities (ARIC) Study. *Circulation* 2004;109:837–842.
22. Folsom AR, Wu KK, Rosamond WD, Sharrett AR, Chambless LE. Prospective study of hemostatic factors and incidence of coronary heart disease: the Atherosclerosis Risk in Communities (ARIC) Study. *Circulation* 1997;96:1102–1108.
23. Malik I, Danesh J, Whincup P, et al. Soluble adhesion molecules and prediction of coronary heart disease: a prospective study and meta-analysis. *Lancet* 2001;358:971–976.
24. Folsom AR. Hemostatic risk factors for atherothrombotic disease: an epidemiologic view. *Thromb Haemost* 2001;86:366–373.
25. Calabro P, Willerson JT, Yeh ET. Inflammatory cytokines stimulated C-reactive protein production by human coronary artery smooth muscle cells. *Circulation* 2003;108:1930–1932.
26. Jabs WJ, Theissing E, Nitschke M, et al. Local generation of C-reactive protein in diseased coronary artery venous bypass grafts and normal vascular tissue. *Circulation* 2003;108:1428–1431.
27. Yasojima K, Schwab C, McGeer EG, McGeer PL. Generation of C-reactive protein and complement components in atherosclerotic plaques. *Am J Pathol* 2001;158:1039–1051.
28. Pasceri V, Willerson JT, Yeh ET. Direct proinflammatory effect of C-reactive protein on human endothelial cells. *Circulation* 2000;102:2165–2168.
29. Pasceri V, Cheng JS, Willerson JT, Yeh ET, Chang J. Modulation of C-reactive protein-mediated monocyte chemoattractant protein-1 induction in human endothelial cells by anti-atherosclerosis drugs. *Circulation* 2001;103:2531–2534.
30. Verma S, Li SH, Badiwala MV, et al. Endothelin antagonism and interleukin-6 inhibition attenuate the proatherogenic effects of C-reactive protein. *Circulation* 2002;105:1890–1896.
31. Devaraj S, Xu DY, Jialal I. C-reactive protein increases plasminogen activator inhibitor-1 expression and activity in human aortic endothelial cells: implications for the metabolic syndrome and atherothrombosis. *Circulation* 2003;107:398–404.
32. Venugopal SK, Devaraj S, Yuhanna I, Shaul P, Jialal I. Demonstration that C-reactive protein decreases eNOS expression and bioactivity in human aortic endothelial cells. *Circulation* 2002;106:1439–1441.
33. Verma S, Wang CH, Li SH, et al. A self-fulfilling prophecy: C-reactive protein attenuates nitric oxide production and inhibits angiogenesis. *Circulation* 2002;106:913–919.

34. Nakagomi A, Freedman SB, Geczy CL. Interferon-gamma and lipopolysaccharide potentiate monocyte tissue factor induction by C-reactive protein: relationship with age, sex, and hormone replacement treatment. *Circulation* 2000;101:1785–1791.
35. Zwaka TP, Hombach V, Torzewski J. C-reactive protein-mediated low density lipoprotein uptake by macrophages: implications for atherosclerosis. *Circulation* 2001;103:1194–1197.
36. Torzewski J, Torzewski M, Bowyer DE, et al. C-reactive protein frequently colocalizes with the terminal complement complex in the intima of early atherosclerotic lesions of human coronary arteries. *Arterioscler Thromb Vasc Biol* 1998;18:1386–1392.
37. Danenberg HD, Szalai AJ, Swaminathan RV, et al. Increased thrombosis after arterial injury in human C-reactive protein-transgenic mice. *Circulation* 2003;108:512–515.
38. Kuller LH, Tracy RP, Shaten J, Meilahn EN. Relation of C-reactive protein and coronary heart disease in the MRFIT nested case-control study. *Am J Epidemiol* 1996;144:537–547.
39. Ridker PM, Cushman M, Stampfer MJ, Tracy RP, Hennekens CH. Inflammation, aspirin, and the risk of cardiovascular disease in apparently healthy men. *N Engl J Med* 1997;336:973–979.
40. Ridker PM, Glynn RJ, Hennekens CH. C-reactive protein adds to the predictive value of total and HDL cholesterol in determining risk of first myocardial infarction. *Circulation* 1998;97:2007–2011.
41. Ridker PM, Buring JE, Shih J, Matias M, Hennekens CH. Prospective study of C-reactive protein and the risk of future cardiovascular events among apparently healthy women. *Circulation* 1998;98:731–733.
42. Rifai N, Buring JE, Lee IM, Manson JE, Ridker PM. Is C-reactive protein specific for vascular disease in women? *Ann Intern Med* 2002;136:529–533.
43. Tracy RP, Lemaitre RN, Psaty BM, et al. Relationship of C-reactive protein to risk of cardiovascular disease in the elderly: results from the Cardiovascular Health Study and the Rural Health Promotion Project. *Arterioscler Thromb Vasc Biol* 1997;17:1121–1127.
44. Koenig W, Sund M, Frohlich M, et al. C-reactive protein, a sensitive marker of inflammation, predicts future risk of coronary heart disease in initially healthy middle-aged men: results from the MONICA (Monitoring Trends and Determinants in Cardiovascular Disease) Augsburg Cohort Study, 1984 to 1992. *Circulation* 1999;99:237–242.
45. Danesh J, Whincup P, Walker M, et al. Low grade inflammation and coronary heart disease: prospective study and updated meta-analyses. *BMJ* 2000;321:199–204.
46. Mendall MA, Strachan DP, Butland BK, et al. C-reactive protein: relation to total mortality, cardiovascular mortality and cardiovascular risk factors in men. *Eur Heart J* 2000;21:1584–1590.
47. Roivainen M, Viik-Kajander M, Palosuo T, et al. Infections, inflammation, and the risk of coronary heart disease. *Circulation* 2000;101:252–257.
48. Ridker PM, Rifai N, Clearfield M, et al. Measurement of C-reactive protein for the targeting of statin therapy in the primary prevention of acute coronary events. *N Engl J Med* 2001;344:1959–1965.
49. Lowe GD, Yarnell JW, Rumley A, Bainton D, Sweetnam PM. C-reactive protein, fibrin D-dimer, and incident ischemic heart disease in the Speedwell study: are inflammation and fibrin turnover linked in pathogenesis? *Arterioscler Thromb Vasc Biol* 2001;21:603–610.
50. Park R, Detrano R, Xiang M, et al. Combined use of computed tomography coronary calcium scores and C-reactive protein levels in predicting cardiovascular events in nondiabetic individuals. *Circulation* 2002;106:2073–2077.
51. Folsom AR, Aleksis N, Catellier D, Juneja HS, Wu KK. C-reactive protein and incident coronary heart disease in the Atherosclerosis Risk In Communities (ARIC) study. *Am Heart J* 2002;144:233–238.
52. Pradhan AD, Manson JE, Rossouw JE, et al. Inflammatory biomarkers, hormone replacement therapy, and incident coronary heart disease: prospective analysis from the Women’s Health Initiative observational study. *JAMA* 2002;288:980–987.
53. Sakkinen P, Abbott RD, Curb JD, Rodriguez BL, Yano K, Tracy RP. C-reactive protein and myocardial infarction. *J Clin Epidemiol* 2002;55:445–451.
54. Witherell HL, Smith KL, Friedman GD, et al. C-reactive protein, *Helicobacter pylori*, Chlamydia pneumoniae, cytomegalovirus and risk for myocardial infarction. *Ann Epidemiol* 2003;13:170–177.
55. van der Meer IM, de Maat MP, Kiliaan AJ, van der Kuip DA, Hofman A, Witteman JC. The value of C-reactive protein in cardiovascular risk prediction: the Rotterdam Study. *Arch Intern Med* 2003;163:1323–1328.
56. Koenig W, Lowel H, Baumert J, Meisinger C. C-reactive protein modulates risk prediction based on the Framingham Score: implications for future risk assessment. *Circulation* 2004;109:1349–1353.
57. Danesh J, Wheeler JG, Hirschfield GM, et al. C-reactive protein and other circulating markers of inflammation in the prediction of coronary heart disease. *N Engl J Med* 2004;350:1387–1397.

58. Pai JK, Pischon T, Ma J, et al. Inflammatory markers and risk of coronary heart disease in men and women. *N Engl J Med* 2004;351:2599–2610.
59. Gussekloo J, Schaap MC, Frohlich M, Blauw GJ, Westendorp RG. C-reactive protein is a strong but non-specific risk factor for fatal stroke in elderly persons. *Arterioscler Thromb Vasc Biol* 2000;20:1047–1051.
60. Rost NS, Wolf PA, Kase CS, et al. Plasma concentration of C-reactive protein and risk of ischemic stroke and transient ischemic attack: the Framingham Study. *Stroke* 2001;32:2575–2579.
61. Curb JD, Abbott RD, Rodriguez BL, et al. C-reactive protein and the future risk of thromboembolic stroke in healthy men. *Circulation* 2003;107:2016–2020.
62. Cao JJ, Thach C, Manolio TA, et al. C-reactive protein, carotid intima-media thickness, and incidence of ischemic stroke in the elderly: the Cardiovascular Health Study. *Circulation* 2003;108:166–170.
63. Ridker PM, Cushman M, Stampfer MJ, Tracy RP, Hennekens CH. Plasma concentration of C-reactive protein and risk of developing peripheral vascular disease. *Circulation* 1998;97:425–428.
64. Vasan RS, Sullivan LM, Roubenoff R, et al. Inflammatory markers and risk of heart failure in elderly subjects without prior myocardial infarction: the Framingham Heart Study. *Circulation* 2003;107:1486–1491.
65. Cesari M, Penninx BW, Newman AB, et al. Inflammatory markers and onset of cardiovascular events: results from the Health ABC study. *Circulation* 2003;108:2317–2322.
66. Aviles RJ, Martin DO, Apperson-Hansen C, et al. Inflammation as a risk factor for atrial fibrillation. *Circulation* 2003;108:3006–3010.
67. Albert CM, Ma J, Rifai N, Stampfer MJ, Ridker PM. Prospective study of C-reactive protein, homocysteine, and plasma lipid levels as predictors of sudden cardiac death. *Circulation* 2002;105:2595–2599.
68. Expert Panel on Detection Evaluation and Treatment of High Blood Cholesterol in Adults. Executive summary of the Third Report of the National Cholesterol Education Program (NCEP) Expert Panel on Detection, Evaluation, and Treatment of High Blood Cholesterol in Adults (Adult Treatment Panel III). *JAMA* 2001;285:2486–2497.
69. Ridker PM, Cook NR. Clinical usefulness of very high and very low levels of C-reactive protein across the full range of Framingham risk scores. *Circulation* 2004;109:1955–1959.
70. Ridker PM, Wilson PW, Grundy SM. Should C-reactive protein be added to metabolic syndrome and to assessment of global cardiovascular risk? *Circulation* 2004;109:2818–2825.
71. Albert MA, Glynn RJ, Ridker PM. Plasma concentration of C-reactive protein and the calculated Framingham Coronary Heart Disease Risk Score. *Circulation* 2003;108:161–165.
72. Lakka HM, Laaksonen DE, Lakka TA, et al. The metabolic syndrome and total and cardiovascular disease mortality in middle-aged men. *JAMA* 2002;288:2709–2716.
73. Sesso HD, Buring JE, Rifai N, Blake GJ, Gaziano JM, Ridker PM. C-reactive protein and the risk of developing hypertension. *JAMA* 2003;290:2945–2951.
74. Pradhan AD, Cook NR, Buring JE, Manson JE, Ridker PM. C-reactive protein is independently associated with fasting insulin in nondiabetic women. *Arterioscler Thromb Vasc Biol* 2003;23:650–655.
75. Ridker PM, Buring JE, Cook NR, Rifai N. C-reactive protein, the metabolic syndrome, and risk of incident cardiovascular events: an 8-year follow-up of 14,719 initially healthy American women. *Circulation* 2003;107:391–397.
76. Sattar N, Gaw A, Scherbakova O, et al. Metabolic syndrome with and without C-reactive protein as a predictor of coronary heart disease and diabetes in the West of Scotland Coronary Prevention Study. *Circulation* 2003;108:414–419.
77. Rutter MK, Meigs JB, Sullivan LM, D'Agostino RB Sr, Wilson PW. C-reactive protein, the metabolic syndrome, and prediction of cardiovascular events in the Framingham Offspring Study. *Circulation* 2004;110:380–385.
78. Schulze MB, Rimm EB, Li T, Rifai N, Stampfer MJ, Hu FB. C-reactive protein and incident cardiovascular events among men with diabetes. *Diabetes Care* 2004;27:889–894.
79. Freeman DJ, Norrie J, Caslake MJ, et al. C-reactive protein is an independent predictor of risk for the development of diabetes in the West of Scotland Coronary Prevention Study. *Diabetes* 2002;51:1596–1600.
80. Pradhan AD, Manson JE, Rifai N, Buring JE, Ridker PM. C-reactive protein, interleukin-6, and risk of developing type 2 diabetes mellitus. *JAMA* 2001;286:327–334.
81. Hu FB, Meigs JB, Li TY, Rifai N, Manson JE. Inflammatory markers and risk of developing type 2 diabetes in women. *Diabetes* 2004;53:693–700.
82. Barzilay JI, Abraham L, Heckbert SR, et al. The relation of markers of inflammation to the development of glucose disorders in the elderly: the Cardiovascular Health Study. *Diabetes* 2001;50:2384–2389.

83. Thorand B, Lowel H, Schneider A, et al. C-reactive protein as a predictor for incident diabetes mellitus among middle-aged men: results from the MONICA Augsburg cohort study, 1984–1998. *Arch Intern Med* 2003;163:93–99.
84. Festa A, D'Agostino R Jr, Tracy RP, Haffner SM. Elevated levels of acute-phase proteins and plasminogen activator inhibitor-1 predict the development of type 2 diabetes: the Insulin Resistance Atherosclerosis Study. *Diabetes* 2002;51:1131–1137.
85. Muntner P, Hamm LL, Kusek JW, Chen J, Whelton PK, He J. The prevalence of nontraditional risk factors for coronary heart disease in patients with chronic kidney disease. *Ann Intern Med* 2004;140:9–17.
86. deFilippi C, Wasserman S, Rosanio S, et al. Cardiac troponin T and C-reactive protein for predicting prognosis, coronary atherosclerosis, and cardiomyopathy in patients undergoing long-term hemodialysis. *JAMA* 2003;290:353–359.
87. Wang TJ, Nam BH, Wilson PW, et al. Association of C-reactive protein with carotid atherosclerosis in men and women: the Framingham Heart Study. *Arterioscler Thromb Vasc Biol* 2002;22:1662–1667.
88. Wang TJ, Larson MG, Levy D, et al. C-reactive protein is associated with subclinical epicardial coronary calcification in men and women: the Framingham Heart Study. *Circulation* 2002;106:1189–1191.
89. van der Meer IM, de Maat MP, Bots ML, et al. Inflammatory mediators and cell adhesion molecules as indicators of severity of atherosclerosis: the Rotterdam Study. *Arterioscler Thromb Vasc Biol* 2002;22:838–842.
90. Nissen SE, Tuzcu EM, Schoenhagen P, et al. Effect of intensive compared with moderate lipid-lowering therapy on progression of coronary atherosclerosis: a randomized controlled trial. *JAMA* 2004;291:1071–1080.
91. Folsom AR, Pankow JS, Tracy RP, et al. Association of C-reactive protein with markers of prevalent atherosclerotic disease. *Am J Cardiol* 2001;88:112–117.
92. Reilly MP, Wolfe ML, Localio AR, Rader DJ. C-reactive protein and coronary artery calcification: the Study of Inherited Risk of Coronary Atherosclerosis (SIRCA). *Arterioscler Thromb Vasc Biol* 2003;23:1851–1856.
93. Burke AP, Tracy RP, Kolodgie F, et al. Elevated C-reactive protein values and atherosclerosis in sudden coronary death: association with different pathologies. *Circulation* 2002;105:2019–2023.
94. Ridker PM, Rifai N, Pfeffer MA, et al. Inflammation, pravastatin, and the risk of coronary events after myocardial infarction in patients with average cholesterol levels. Cholesterol and Recurrent Events (CARE) Investigators. *Circulation* 1998;98:839–844.
95. Retterstol L, Eikvar L, Bohn M, Bakken A, Erikssen J, Berg K. C-reactive protein predicts death in patients with previous premature myocardial infarction—a 10-year follow-up study. *Atherosclerosis* 2002;160:433–440.
96. Ridker PM, Cannon CP, Morrow D, et al. C-reactive protein levels and outcomes after statin therapy. *N Engl J Med* 2005;352:20–28.
97. Harb TS, Zareba W, Moss AJ, et al. Association of C-reactive protein and serum amyloid A with recurrent coronary events in stable patients after healing of acute myocardial infarction. *Am J Cardiol* 2002;89:216–221.
98. Tice JA, Browner W, Tracy RP, Cummings SR. The relation of C-reactive protein levels to total and cardiovascular mortality in older U.S. women. *Am J Med* 2003;114:199–205.
99. Ridker PM. Clinical application of C-reactive protein for cardiovascular disease detection and prevention. *Circulation* 2003;107:363–369.
100. Blake GJ, Ridker PM, Kuntz KM. Projected life-expectancy gains with statin therapy for individuals with elevated C-reactive protein levels. *J Am Coll Cardiol* 2002;40:49–55.
101. Ridker PM, Rifai N, Pfeffer MA, Sacks F, Braunwald E. Long-term effects of pravastatin on plasma concentration of C-reactive protein: the Cholesterol and Recurrent Events (CARE) Investigators. *Circulation* 1999;100:230–235.
102. Balk EM, Lau J, Goudas LC, et al. Effects of statins on nonlipid serum markers associated with cardiovascular disease: a systematic review. *Ann Intern Med* 2003;139:670–682.
103. Albert MA, Danielson E, Rifai N, Ridker PM. Effect of statin therapy on C-reactive protein levels: the Pravastatin Inflammation/CRP Evaluation (PRINCE), a randomized trial and cohort study. *JAMA* 2001;286:64–70.
104. Ridker PM, Rifai N, Lowenthal SP. Rapid reduction in C-reactive protein with cerivastatin among 785 patients with primary hypercholesterolemia. *Circulation* 2001;103:1191–1193.
105. Bays HE, Stein EA, Shah AK, Maccubbin DL, Mitchel YB, Mercuri M. Effects of simvastatin on C-reactive protein in mixed hyperlipidemic and hypertriglyceridemic patients. *Am J Cardiol* 2002;90:942–946.

106. Ballantyne CM, Hourii J, Notarbartolo A, et al. Effect of ezetimibe coadministered with atorvastatin in 628 patients with primary hypercholesterolemia: a prospective, randomized, double-blind trial. *Circulation* 2003;107:2409–2415.
107. Kinlay S, Timms T, Clark M, et al. Comparison of effect of intensive lipid lowering with atorvastatin to less intensive lowering with lovastatin on C-reactive protein in patients with stable angina pectoris and inducible myocardial ischemia. *Am J Cardiol* 2002;89:1205–1207.
108. Kinlay S, Schwartz GG, Olsson AG, et al. High-dose atorvastatin enhances the decline in inflammatory markers in patients with acute coronary syndromes in the MIRACL study. *Circulation* 2003;108:1560–1566.
109. Gagne C, Bays HE, Weiss SR, et al. Efficacy and safety of ezetimibe added to ongoing statin therapy for treatment of patients with primary hypercholesterolemia. *Am J Cardiol* 2002;90:1084–1091.
110. Ridker PM. Rosuvastatin in the primary prevention of cardiovascular disease among patients with low levels of low-density lipoprotein cholesterol and elevated high-sensitivity C-reactive protein: rationale and design of the JUPITER trial. *Circulation* 2003;108:2292–2297.
111. Chew DP, Bhatt DL, Robbins MA, et al. Effect of clopidogrel added to aspirin before percutaneous coronary intervention on the risk associated with C-reactive protein. *Am J Cardiol* 2001;88:672–674.
112. Lincoff AM, Kereiakes DJ, Mascelli MA, et al. Abciximab suppresses the rise in levels of circulating inflammatory markers after percutaneous coronary revascularization. *Circulation* 2001;104:163–167.
113. Vivekananthan DP, Bhatt DL, Chew DP, et al. Effect of clopidogrel pretreatment on periprocedural rise in C-reactive protein after percutaneous coronary intervention. *Am J Cardiol* 2004;94:358–360.
114. Di Napoli M, Papa F. Inflammation, hemostatic markers, and antithrombotic agents in relation to long-term risk of new cardiovascular events in first-ever ischemic stroke patients. *Stroke* 2002;33:1763–1771.
115. Ikonomidis I, Andreotti F, Economou E, Stefanadis C, Toutouzias P, Nihoyannopoulos P. Increased pro-inflammatory cytokines in patients with chronic stable angina and their reduction by aspirin. *Circulation* 1999;100:793–798.
116. Feldman M, Jialal I, Devaraj S, Cryer B. Effects of low-dose aspirin on serum C-reactive protein and thromboxane B2 concentrations: a placebo-controlled study using a highly sensitive C-reactive protein assay. *J Am Coll Cardiol* 2001;37:2036–2041.
117. Feng D, Tracy RP, Lipinska I, Murillo J, McKenna C, Tofler GH. Effect of short-term aspirin use on C-reactive protein. *J Thromb Thrombolysis* 2000;9:37–41.
118. Haffner SM, Greenberg AS, Weston WM, Chen H, Williams K, Freed MI. Effect of rosiglitazone treatment on nontraditional markers of cardiovascular disease in patients with type 2 diabetes mellitus. *Circulation* 2002;106:679–684.
119. Ridker PM, Hennekens CH, Rifai N, Buring JE, Manson JE. Hormone replacement therapy and increased plasma concentration of C-reactive protein. *Circulation* 1999;100:713–716.
120. Cushman M, Legault C, Barrett-Connor E, et al. Effect of postmenopausal hormones on inflammation-sensitive proteins: the Postmenopausal Estrogen/Progestin Interventions (PEPI) Study. *Circulation* 1999;100:717–722.
121. Manson JE, Hsia J, Johnson KC, et al. Estrogen plus progestin and the risk of coronary heart disease. *N Engl J Med* 2003;349:523–534.
122. Wassertheil-Smoller S, Hendrix SL, Limacher M, et al. Effect of estrogen plus progestin on stroke in postmenopausal women: the Women's Health Initiative: a randomized trial. *JAMA* 2003;289:2673–2684.
123. Herrington DM, Brosnihan KB, Pusser BE, et al. Differential effects of E and droloxifene on C-reactive protein and other markers of inflammation in healthy postmenopausal women. *J Clin Endocrinol Metab* 2001;86:4216–4222.
124. Vongpatanasin W, Tuncel M, Wang Z, Arbique D, Mehrad B, Jialal I. Differential effects of oral versus transdermal estrogen replacement therapy on C-reactive protein in postmenopausal women. *J Am Coll Cardiol* 2003;41:1358–1363.
125. Ridker PM. Cardiology Patient Page. C-reactive protein: a simple test to help predict risk of heart attack and stroke. *Circulation* 2003;108:e81–e85.

# 17

---

## High-Sensitivity C-Reactive Protein for Risk Assessment in Acute Coronary Syndromes

---

*Luigi M. Biasucci, MD, FACC, FAHA, FESC  
and Antonio Abbate, MD*

### CONTENTS

ACUTE CORONARY SYNDROME: AN INFLAMMATORY DISEASE  
C-REACTIVE PROTEIN AS PREFERRED “INFLAMMATORY”  
MARKER FOR RISK STRATIFICATION  
CRP AND OTHER INFLAMMATORY MARKERS  
ROLE OF CRP IN A MULTIMARKER ASSESSMENT APPROACH  
INFLAMMATORY MARKERS: BEYOND RISK STRATIFICATION  
AND BACK TO MECHANISMS OF DISEASE  
PRACTICAL CONSIDERATIONS  
CONCLUSION  
REFERENCES

---

### SUMMARY

This chapter summarizes the rationale and evidence in support of the clinical use of inflammatory markers for risk prediction in patients with ischemic heart disease. Available data summarized in statements and guidelines of international societies recommend the use of C-reactive protein (CRP) as the sole inflammatory prognostic marker in patients with acute coronary syndromes, in addition to other prognostic factors, including troponin levels. Elevated levels of CRP at admission are associated with significantly worse in-hospital and mid- to long-term outcome, and CRP levels within the normal range have a very high negative predictive value for adverse events.

**Key Words:** Acute coronary syndrome; C-reactive protein; inflammation; prognosis.

### ACUTE CORONARY SYNDROME: AN INFLAMMATORY DISEASE

Because acute coronary syndromes (ACSs) are heterogeneous with respect to their pathogenesis, it may be anticipated that they are also varied with respect to their risk and appropriate treatment (1,2). The growing evidence that atherosclerosis is an inflammatory

From: *Contemporary Cardiology:  
Cardiovascular Biomarkers: Pathophysiology and Disease Management*  
Edited by: David A. Morrow © Humana Press Inc., Totowa, NJ



disease and that inflammation plays a pivotal role in the complex processes that are responsible for destabilization of atherosclerosis have led to the use of inflammatory markers as risk predictors and potential guides for therapy in these syndromes (3–9). Traditional cardiovascular risk factors, such as diabetes, hypertension, smoking, family history, obesity, and sedentary lifestyle, explain only in part the occurrence of ACS. For example, more than 50% of patients with ACS have normal levels of cholesterol. The potential to identify patients at increased risk of future cardiovascular events by assessing their “inflammatory” status is appealing because this approach may also be useful for targeting more appropriate and specific therapy in high-risk individuals with evidence of inflammation.

Patients with ACS are characterized by a high rate of adverse in-hospital events, and by a high rate of recurrence, remaining around 15% despite contemporary aggressive therapy, in the months following the index event (10). The latter observation strongly suggests that treatment of the culprit plaque may reduce the short-term risk of events but does not significantly affect the underlying atherosclerotic and inflammatory process. Thus, the potential for targeting therapy specific to inflammatory contributors to atherothrombosis may be of particular importance for secondary prevention in the long term.

Cardiac troponin is a cornerstone for risk assessment in ACS and is effective in guiding the use of aggressive antithrombotic therapy (11–13). However, only a minority of patients with ACSs have elevated levels of troponins when they present to the emergency room, thus reducing the diagnostic and prognostic effectiveness of this marker. On the other hand, CRP, as a marker of inflammation, may better represent the activity of the underlying disease responsible for acute ischemia and therefore both the short-term risk, in patients with normal troponin, in particular, and the long-term prognosis.

## C-REACTIVE PROTEIN AS PREFERRED “INFLAMMATORY” MARKER FOR RISK STRATIFICATION

### *Prognostic Application of C-Reactive Protein in ACS*

C-reactive protein (CRP) is the inflammatory marker most extensively studied in cardiovascular disease (CVD). The advantages of CRP as an inflammatory biomarker are related in part to analytic properties (such as the availability of low-cost, accurate high-sensitivity assays) and in part to its biological profile, including a long half-life (19 h) (3,7,8).

The prognostic capacity of CRP measured either at presentation or at discharge of patients with ACS is supported by almost 20 clinical studies (Table 1). In the majority but not all studies, CRP has been shown to be a marker of the short-term risk (in-hospital or 30 d) of recurrent cardiac events, including death, acute myocardial infarction (AMI), and urgent revascularization (14,15). This association is independent of and of similar magnitude to other major clinical predictors of complications in ACS, including age, ST-abnormalities, and cardiac troponin (Fig. 1). More important, this prognostic relationship is not merely a consequence of the inflammatory response to myocardial necrosis and is present in patients with no evidence of myocardial injury as detected by cardiac troponin (9,14). In addition to a relationship to short-term risk, CRP is independently associated with the recurrence of cardiovascular events in the mid to long term (Fig. 2) (16–20). Notably CRP is an independent predictor of the risk of death in follow-up ranging from 90 d to 4 yr (14–18). Several, but not all, studies indicate that the relationship between CRP and outcome may be strongest with respect to mortality, with a weaker relationship to recurrent MI (17).

Table 1  
 Predictive Role of CRP Levels in Patients With Non-ST-Elevation ACSs

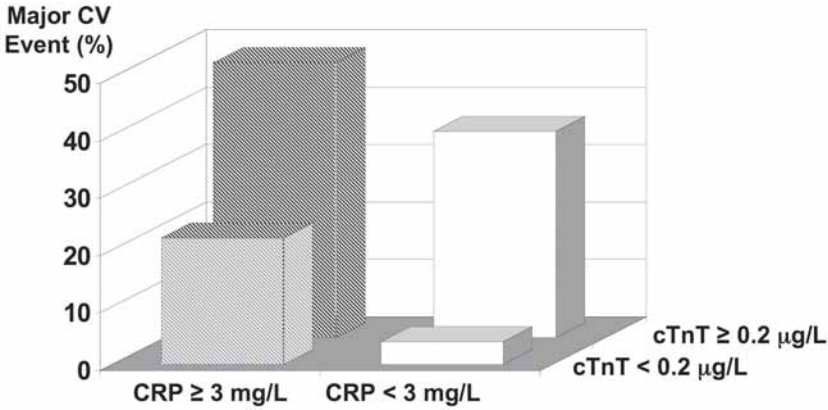
Study (Reference)	n	Syndrome	CRP measurement			End point		
			hsCRP	Timing	Cutoff (mg/L)	Type	Timing	Relative risk (95% CI)
Baldus et al. (60)	1090	NSTEMACS	Yes	Admission	10	D/AMI	6 mo	1.25 (1.02–1.7)
Bazzino et al. (61)	139	UA	No	Admission	15	D/AMI	3 mo	18.6 (4.5–77)
Benamer et al. (62)	100	UA	No	Admission	6	D/AMI/RA/UR	In hospital	0.65 (0.17–2.1)
Bholasingh et al. (63)	382	UA	Yes	Admission	3	D/AMI	6 mo	5.6 (1.5–22.2)
Biasucci et al. (18)	53	UA	Yes	Discharge	3	D/AMI/RA	1 yr	4.7 (1.8–12.0)
						D/AMI	1 yr	4.2 (0.50–34)
Bodi et al. (64)	515	NSTEMACS	Yes	Admission	11	D/AMI	6 mo	2.1 (1.2–3.8)
de Winter et al. (65)	150	NSTEMACS	Yes	Admission	5	D/AMI/RA	6 mo	9.8 (1.5–65)
Ferreiros et al. (66)	105	UA	No	Admission	15	D/AMI/RA	In hospital	0.83 (0.29–2.4)
						D/AMI	In hospital	0.71 (0.16–3.2)
						D/AMI/RA	3 mo	2.1 (1.5–3.1)
						D/AMI	3 mo	2.3 (1.3–4.2)
Heeschen et al. (20)	447	NSTEMACS	Yes	Admission	10	D/AMI	6 mo	1.98 (1.2–3.2)
						D	6 mo	4.7 (1.3–16.9)
James et al. (17)	7108	NSTEMACS	Yes	Admission	10	D	1 mo	1.2 (1.05–1.4)
Lindhal et al. (19)	917	NSTEMACS	No	Admission	10	D	3 yr	2.5 (1.6–3.9)
Liuzzo et al. (9)	31	UA	Yes	Admission	3	D/AMI/RA/UR	In hospital	4.5 (1.4–17.5)
						D	12 mo	1.5 (1.1–1.9)

(continued)

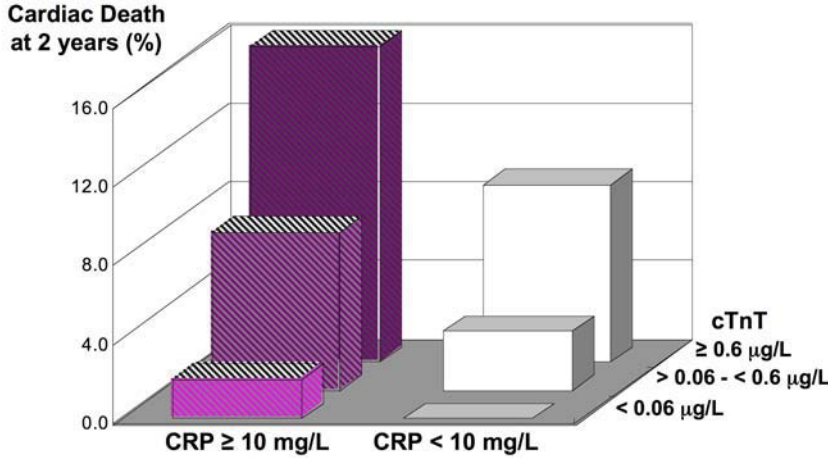
Table 1 (Continued)

Study (Reference)	n	Syndrome	CRP measurement			End point		
			hsCRP	Timing	Cutoff (mg/L)	Type	Timing	Relative risk (95% CI)
Müller et al. (16)	1042	NSTEACS	No	Admission	10	D	In hospital	4.2 (1.6–10.9)
						D	20 mo	3.8 (2.3–6.2)
Morrow et al. (14)	437	NSTEACS	Yes	Admission	15.5	D	In hospital	18.3 (2.2–150)
Mulvihill et al. (37)	91	NSTEACS	Yes	Admission	3	D/AMI/RA	6 mo	9.8 (2.5–38.9)
Oltrona et al. (67)	191	UA	No	Admission	3	D/AMI/UR	In hospital	0.46 (0.19–1.11)
						D/AMI	In hospital	1.94 (0.46–8.3)
Oltrona et al. (68)	1773	NSTEACS	Yes	Admission	3	D/AMI	1 mo	1.4 (1.0–2.1)
						D	1 mo	1.7 (1.1–2.6)
Rebuzzi et al. (69)	102	UA	Yes	Admission	3	AMI	3 mo	6.0 (1.4–25.3)
Sanchez et al. (70)	83	Diabetics with NSTEMACS	No	Admission	5	D	22 mo	4.5 (1.6–12.5)
Toss et al. (71)	965	NSTEMACS	No	Admission	10	D/AMI	5 mo	1.19 (0.97–1.64)
Versaci et al. (23)	62	UA	No	Admission	5	D/AMI/RA	12 mo	22.2 (3.1–157)
Zebrack et al. (72)	442	UA	Yes	Admission	11	D/AMI	3 yr	2.6 (1.4–4.8)
						D	3 yr	2.8 (1.2–6.3)

CI, confidence interval; D, death; NSTEMACS, non-ST-elevation ACSs; RA, refractory angina; UA, unstable angina; UR, urgent revascularization.



**Fig. 1.** Incremental prognostic value of CRP in addition to troponin T for prediction of major adverse coronary events at 6 mo in patients with ACSs. The highest risk is confined to patients with elevations in both markers, whereas double-negative markers predict more favorable outcome. cTnT, cardiac troponin T; CV, cardiovascular. (Modified from ref. 69.)



**Fig. 2.** Risk of cardiac death through 2 yr of follow-up after presentation with non-ST-elevation ACS stratified by CRP and cardiac troponin T (cTnT) at presentation. (Data from ref. 19.)

### Clinical Cut Points for CRP in ACS

A variety of cut points have been applied in clinical studies of CRP in ACS, leaving some uncertainty with respect to the optimal decision limit. Although available data, especially those deriving from primary prevention studies, show no definite threshold below which CRP levels are not associated with cardiovascular risk, the relationship is graded with a very low risk reported for CRP levels <2.0 mg/L (17). Expert guidelines from the American Heart Association (AHA)/Centers for Disease Control (CDC) provided recommendations regarding the preferred cut points for primary prevention but did not give specific recommendations for risk stratification in ACS; rather, they suggested that a higher cutoff value, such as 10 mg/L, is appropriate for unstable patients (3). Liuzzo et al. (9) applied a cut point of 3 mg/L, based on the 90th percentile of a normal distribution. Dichotomized at this cut point, CRP identified patients at increased risk of in-hospital recurrent ischemic events. Other investigators have specifically evaluated the predictive value of CRP for death after ACS and found superior prognostic performance at a higher decision limit (e.g., 15 mg/L)

(14). This observation has been validated by subsequent studies, including a study by Biasucci et al. (15), who later confirmed that levels of CRP >15 mg/L distinguished those patients at higher risk of death. Among patients with unstable coronary disease, CRP > 2 mg/L identified a population at higher risk, with a particularly high mortality in patients with CRP > 10 mg/L (19). Similarly, Mueller et al. (16) found that a serum CRP >3 mg/L was associated with a higher risk of death in patients with non-ST-elevation ACS, with even higher mortality in those with a CRP >10 mg/L, despite aggressive management with early invasive therapy. With validation of this decision limit in two additional large studies in ACS (11, 17), a CRP concentration >10 mg/L appears to be the optimal cut point (when applied during the index hospitalization) for prediction of new AMI and death in secondary prevention. Nevertheless, the clinician should recognize the graded nature of the risk relationship to the probability of a recurrent event increasing significantly when CRP levels are above standard reference values for healthy people (3 mg/L) and even more so when CRP levels are higher than 10 mg/L. In addition, some experts propose that although a cut point of 10 mg/L may be optimal for prediction of mortality, it may not be best with respect to assessing the risk of recurrent ischemic events (8). Moreover, use of the standard cut points recommended by the AHA/CDC is likely preferable when CRP is measured during the convalescent phase (e.g., beyond 30 d) after ACS.

### *Prediction of Clinical Recurrence After Percutaneous Coronary Intervention*

The concept of clinical recurrence is of particular interest when considering patients undergoing percutaneous coronary intervention (PCI), whether for management of ACS or in patients undergoing elective PCI. In the current era of continued frequent use of bare-metal stents in some regions of the world, clinical restenosis after PCI in patients with ACS is expected in approx 20% of patients. Evidence provided by some studies suggests that the recurrence of clinical events after PCI is confined to patients with high CRP levels (21–24). In these studies, the risk of death or MI following PCI in patients with low CRP levels (<3–5 mg/L) was very low (<1%) (21–24). This observation may have important consequences for follow-up and treatment of patients with ACS managed with contemporary early invasive therapy. Versaci et al. (25) have showed that by targeting potent anti-inflammatory therapy (high-dose prednisone) to those patients with effort-induced stable angina pectoris and high inflammatory activity (persistent CRP >5 mg/L within 72 h after stenting), a striking 85% reduction in adverse events at 12 mo may be achieved, a reduction similar to that achieved by drug-eluting stents. The prognostic role of CRP values in patients undergoing drug-eluting stent implantation has not been characterized to date.

## **CRP AND OTHER INFLAMMATORY MARKERS**

CRP is one of a pool of proteins whose plasma levels increase significantly during the inflammatory response (“acute-phase proteins”) (26). These and other markers of inflammation are mentioned briefly here and discussed in detail elsewhere. Serum amyloid A (SAA) is significantly associated with in-hospital risk in studies that evaluated this acute-phase reactant, alone or in combination with CRP (9). Several studies have also evaluated the prognostic value of cytokines for in-hospital assessment of risk in ACS. Interleukin (IL)-6 represents the major inducer of hepatic synthesis of CRP and is itself produced by mononuclear inflammatory cells in response to the release of primary cytokines such as IL-1, interferon (IFN)- $\gamma$ , or tumor necrosis factor (TNF) at sites of inflammation. Several

cytokines (i.e., IL-6, IL-1 receptor antagonist, soluble IL-2 receptor, IFN- $\gamma$ , IL-18, TNF- $\alpha$ ) are elevated in ACS, and some of these have been shown to be associated with the risk of death, MI, and recurrent ischemic events (27–35). In addition, leukocyte adhesion molecules have been associated with adverse events in ischemic heart disease (i.e., intercellular adhesion molecule-1 and soluble vascular cell adhesion molecule-1) (36,37).

However, because of the short half-life of these markers, their typically very low plasma concentrations, and methods of measurement that lack standardization and are costly and time-consuming, use of cytokines and adhesion molecules for clinical purposes is not established. However, these markers remain of importance for pathophysiological studies.

## ROLE OF CRP IN A MULTIMARKER ASSESSMENT APPROACH

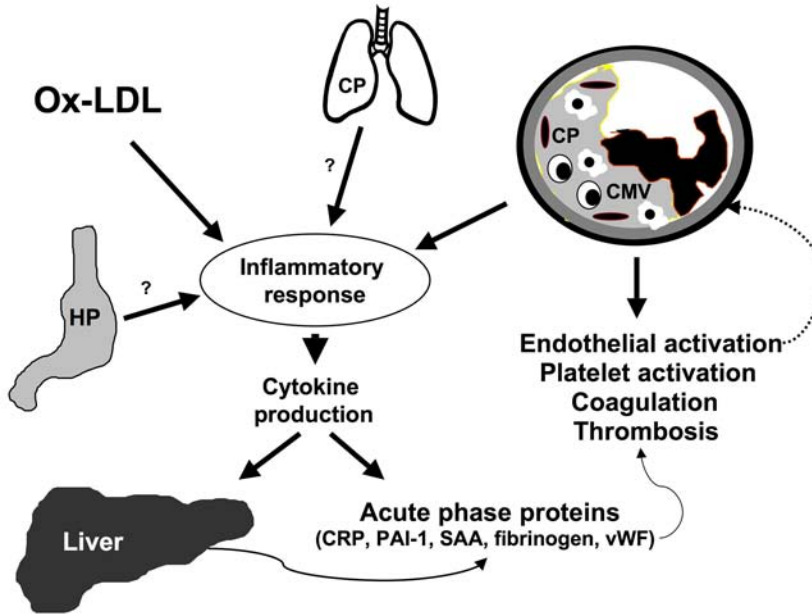
The paradigm of atherosclerosis has been extended beyond the lipid accumulation theory to include the role of inflammation in promoting plaque formation and its complications. The finding of an altered inflammatory status, as shown by elevated levels of CRP, identifies the patient at increased risk. However, the picture may not be complete with assessment of inflammation alone, and risk stratification beyond determination of CRP may be needed. In particular, although CRP may predict the risk of ACS and its recurrence, troponin T or I levels and brain natriuretic peptide levels (mainly reflecting myocardial damage and dysfunction) are able to predict better the short-term risk of death.

### INFLAMMATORY MARKERS: BEYOND RISK STRATIFICATION AND BACK TO MECHANISMS OF DISEASE

#### *CRP as a Marker of Widespread Inflammation*

One of the limitations of CRP as a marker of cardiovascular disease activity is that CRP represents a sensitive but nonspecific marker. It is not specific to vascular or plaque inflammation and, therefore, correlating this protein with CVD is difficult. The more recent and continuously evolving knowledge regarding the pathobiology of ACS suggests a complex and possibly systemic involvement of the endothelium, blood cells, and proteins. The reasons for adverse prognosis in patients with elevated CRP levels are still poorly understood (Fig. 3). Liuzzo et al. (38,39) have described a monoclonal T-cell proliferation in patients with ACS and the expansion of a specific clone displaying CD4<sup>+</sup>CD28-null receptors. The expansion of these inflammatory cells paralleled the risk profile of patients with ACS, providing evidence not only of their importance with respect to risk but also with respect to the pathophysiological mechanism of plaque infiltration and rupture. Furthermore, activated T-cells were also found diffusely in epicardial coronary arteries and in ischemic and nonischemic myocardium in patients with ACS (40,41). These findings led to the concept of widespread inflammation in ACS not confined to culprit plaque or vessel, but involving the entire coronary circulation, the myocardium, and possibly also other vascular districts (40–44). Abbate et al. (42) have reported the presence of widespread inflammation in the myocardium in two-thirds of patients with recent AMI. Others confirmed that the concentration of CRP in patients with ACS correlates with the presence of multiple coronary plaques (43), and complexity of atherosclerotic plaques involving the carotid artery (44).

Given the apparent important role of T-lymphocytes and the fact that these cells have antigen-restricted T-cell receptors, several groups have attempted to search for the culprit



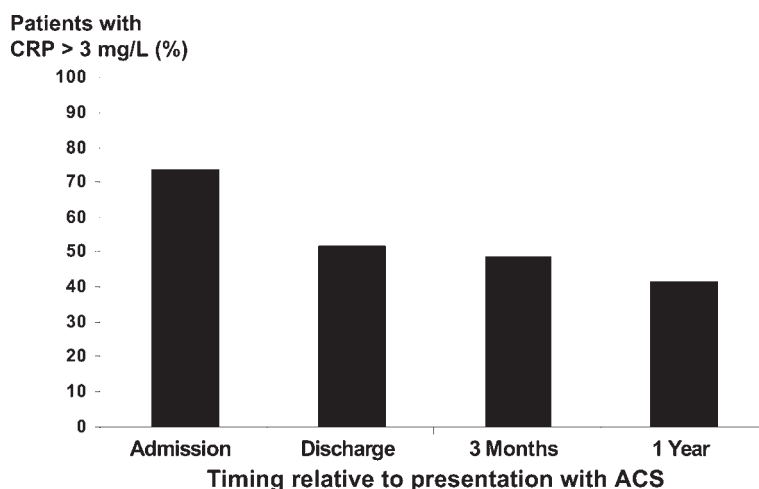
**Fig. 3.** Complex interplay between inflammatory response and progression of atherosclerosis. Inflammatory response is indeed observed in patients with ACSs. The stimuli for inflammation, however, are poorly understood. Several stimuli may be involved, including oxidized low-density lipoprotein (ox-LDL) and other sources of endothelial injury. Localized or systemic infections, in particular from *Helicobacter pylori* (HP), *Chlamydia pneumoniae* (CP), and cytomegalovirus (CMV), have been suggested as promoters of enhanced inflammatory response, but their role is controversial. The inflammatory reaction is responsible for the secondary effects of cytokine production—liver synthesis of acute-phase reactants. CRP, SAA, and fibrinogen are the most widely studied acute-phase proteins. CRP itself is responsible for amplification of the inflammatory response by a direct effect on endothelium, platelets, coagulation, and eventually thrombosis, and the development of acute atherothrombosis further enhances the inflammatory response. vWF, von Willebrand factor.

antigen. Biasucci et al. (45) showed that seropositivity for *C. pneumoniae* heat-shock protein-60 appears to be a very sensitive and specific marker of ACS, unrelated to *C. pneumoniae* IgG antibody titers or high-sensitivity CRP (hsCRP) or troponin T levels, suggesting the possibility of antigen mimicry as a potential mechanism of acute plaque destabilization.

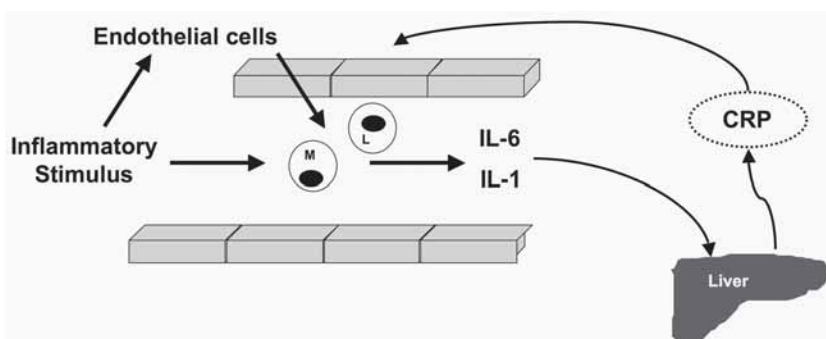
The evidence that patients with ACS and persistently elevated levels of CRP (Fig. 4) have a higher recurrence of events (18) and that these patients respond exaggeratedly to challenges such as coronary angiogram or in vitro stimulation of monocyte with lipopolysaccharide also suggests that subjects with persistently elevated CRP production are prone to overreact to otherwise “mild” stimuli (46) with release of proinflammatory and prothrombotic mediators that may contribute to endothelial erosion and plaque rupture. Alternatively, CRP may also act as a direct participant in promoting atherothrombosis (Fig. 5). Regarding the latter possibility, it is of particular interest that the pattern of the relationship between CRP concentration and cardiovascular risk suggests that CRP behaves as a typical risk factor.

### ***CRP as a Potential Direct Participant in Atherothrombosis***

Several lines of evidence suggest that not only may CRP represent a marker of coronary artery disease (CAD), but that it may also play a direct role in atherothrombosis. CRP may



**Fig. 4.** Persistent elevation in CRP concentration up to 1 yr after index event. (Modified from ref. 18.)



**Fig. 5.** CRP production by the liver is a consequence of intravascular inflammation as well as its promoter. CRP indeed exerts direct effects on endothelium, monocytes (M), and lymphocytes (L).

act either by modulating the inflammatory reaction or by activating the endothelium and the monocyte and, as shown in animal models, by direct procoagulant activity.

Pasceri et al. (47) showed a direct proinflammatory effect of CRP on human umbilical vein and coronary artery cells. Endothelial cells were incubated with recombinant human CRP and the induction of adhesion molecules was assessed by cytofluorimetry. CRP induced expression of adhesion molecules and, intriguingly, this effect was dependent on the presence of human plasma, suggesting the role of some additional inflammatory mediator. CRP also induces production of the chemoattractant monocyte chemoattractant protein-1 (MCP-1), a chemokine involved in monocyte recruitment and activation, by endothelial cells (48). Of interest, simvastatin, but not aspirin, inhibited this action. Liuzzo et al. (49) showed that CRP may induce directly monocyte nuclear factor  $\kappa$ -B, a nuclear factor that is a key step for the synthesis of new proinflammatory mediators.

CRP has been suggested to induce the procoagulant tissue factor in monocyte, although this finding has not been confirmed (50). More recently, Devaraj et al. (51) described a direct prothrombotic property of CRP. In their study, CRP induced production of the procoagulant plasminogen activator inhibitor-1 (PAI-1) in endothelial cells. A prothrombotic



role of CRP has also been elegantly described in an animal model (52). Human CRP transgenic mice were compared with wild-type (WT) mice after mechanical arterial damage. Only human CRP transgenic mice developed thrombotic occlusion of the damaged artery as compared with WT mice, which have only trace CRP, with different properties than in humans. In addition, Wang et al. (53) demonstrated that CRP may change gene expression in endothelial cells. CRP led to overexpression of genes for PAI-1, IL-8, MCP-1, fibronectin-1 and connexin 43, all implicated in thrombosis, inflammation, and atherosclerotic plaque formation.

## PRACTICAL CONSIDERATIONS

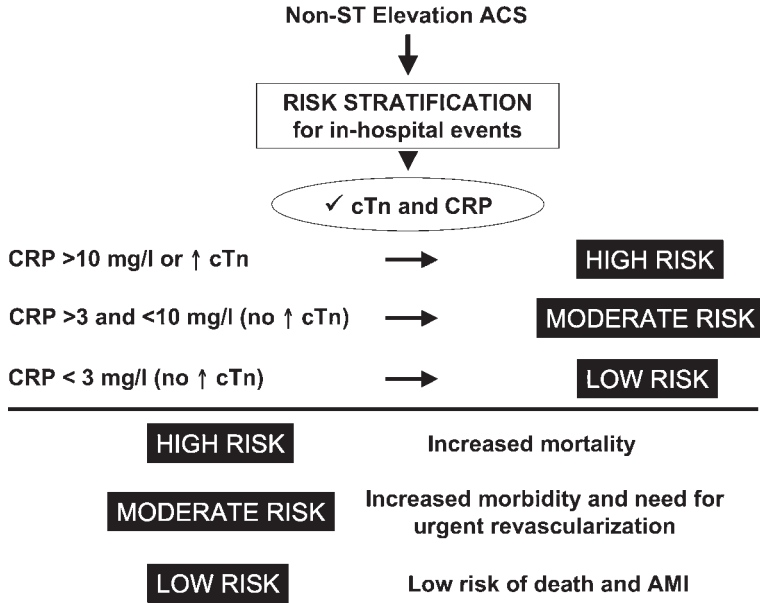
### *Clinical Decision Making*

The independent information offered by CRP testing for risk stratification is now largely accepted. Its clinical use, however, has not yet been widely implemented primarily owing to uncertainty regarding appropriate therapeutic response. For example, although the AHA/CDC guidelines have recognized the use of CRP as an independent tool for risk stratification in secondary prevention (class IIa), the expert committee cautioned against altering therapy based on CRP results (class III) (3). This recommendation derives from the fact that no prospective, randomized study has tested a strategy based on tailoring therapy using the results of testing for CRP. However, based on expanding information regarding the effect of different classes of drugs on CRP, the hypothesis that therapy may be tailored using this inflammatory marker has come to the forefront (54). The observation that lower achieved levels of CRP on statin therapy at 30 d in patients recovering from ACS are associated with more favorable outcomes has offered a major piece of evidence in support of this hypothesis and the achievement of lower levels of CRP as a specific goal of treatment (55).

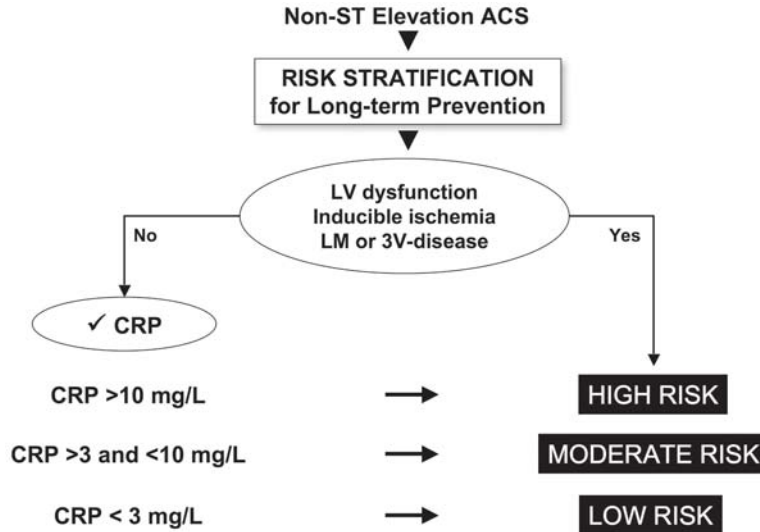
Nevertheless, more data are needed before specific responses to elevated levels of CRP other than control of obesity, treatment of diabetes and dyslipidemia, and exercise can be recommended. Until such time, measurement of CRP may be useful to provide additional independent information with respect to risk in situations in which the patient's risk appears intermediate or is uncertain using traditional tools, or in which the patient is insufficiently motivated to follow established preventive strategies. CRP may be of value for triage of patients with suspected ACS in the emergency department (Fig. 6), particularly when biomarkers of necrosis are normal. In addition, elevated levels of CRP in patients with ACS might also identify those who warrant particularly close follow-up and aggressive postdischarge therapy, such as increased dose of statin, length of clopidogrel therapy, or addition of angiotensin-converting enzyme inhibitors or ARBs in nondiabetic, nonhypertensive patients with normal ejection fraction (Fig. 7).

### *Timing of Testing*

Another issue frequently debated is when to test CRP in patients with ACS. Most studies of CRP in ACS have provided data based on determination of CRP at admission. Therefore, taking an evidence-based approach supports the use of CRP levels at admission for risk stratification. Admission levels are unaffected by revascularization procedures (because PCI may increase CRP levels) and are less likely to be affected by the inflammatory response to necrosis, and more likely to reflect the patient's basal inflammatory status. In addition, measurement at hospital discharge would obviously preclude use for assessment of the risk of in-hospital complications.



**Fig. 6.** Proposed algorithm for short-term risk stratification of patients with non-ST-elevation ACS using CRP. Troponin (cTn) levels identify patients at high risk for in-hospital death and recurrent MI. CRP levels appear to further risk stratify patients without troponin elevation. If CRP is >10 mg/L, the patient is at high risk of AMI and death, whereas the risk is low if CRP is <3 mg/L. Patients with intermediate CRP levels (3–10 mg/L) are at intermediate risk and have increased rates of complicated hospital courses and need for urgent revascularization.



**Fig. 7.** Proposed algorithm for mid to long-term risk stratification of patients recovering from ACS, including CRP. Clinical parameters such as depressed left ventricular (LV) function, inducible ischemia, and severe CAD indicate patients at high risk of recurrence and death and identify those who benefit from more aggressive preventive strategies. CRP determination may be useful for risk stratification in those without high-risk features. The risk strata are as described for Fig. 4. LM, left main coronary artery disease; 3V, triple-vessel coronary artery disease.

Additional determinations during and after hospitalization may be of value. In patients without evidence of myocardial necrosis, reassessment may refine the prognostic assessment for secondary prevention. For example, Biasucci et al. (18) showed that CRP levels at discharge were a better predictor of long-term recurrence than CRP levels on admission. In patients with MI, CRP is expected to rise in response to the inflammatory reaction to necrosis and, thus, the clinical value is debated. However, in patients with AMI, peak CRP levels were associated with the risk of heart failure and/or mechanical complications of AMI (56,57). Therefore, even if CRP elevation is to be expected when myocardial necrosis is present, a higher CRP level may be predictive either of greater myocyte loss or of greater inflammatory burden and in both cases may be associated with adverse outcome. For patients undergoing PCI, an elevated level of CRP 48–72 h after stent implantation may reflect an inflammatory response to PCI and predict clinical recurrence (57). Finally, testing during outpatient follow-up one or more months after presentation appears to assist in long-term risk stratification and may provide a basis for titration of therapy with anti-inflammatory actions (58). Moreover, a lower achieved level of CRP at 6 mo after PCI is associated with a favorable outcome (23,57).

### *Specific Subgroups of Patients*

Present expert consensus is that CRP is less useful for cardiovascular risk assessment in the setting of acute infection (3). In addition, the cardiovascular application of CRP testing in patients who have other systemic inflammatory disease is questionable. However, a marked increase in ischemic heart disease has been reported in patients with rheumatoid arthritis, a typical disease with significantly elevated CRP levels (59). This epidemiological observation raises the possibility that CRP can be useful in such patients. To date, however, there is insufficient evidence to provide guidance regarding appropriate cut points for cardiovascular risk stratification in patients who have other inflammatory diseases.

## CONCLUSION

Available data support the use of CRP in conjunction with troponin and other traditional clinical tools as a prognostic marker in patients with ACS. Accordingly, the AHA/CDC scientific statement on the use of markers of inflammation in cardiovascular disease in clinical practice includes a class IIa recommendation (evidence/opinion favors usefulness) for the use of hsCRP in ACS as an independent marker of prognosis for recurrent events, including death, AMI, and restenosis, after PCIs (level of evidence B) (3). The European Society of Cardiology has made similar suggestions (2). Patients with elevated levels of CRP are at higher absolute risk of recurrent cardiovascular events and, thus, are reasonable candidates for more aggressive monitoring and therapy. Newer data suggest that the risk associated with elevated CRP is modifiable (48). However, the results of ongoing and future research are needed to provide evidence-based guidance with respect to specific therapeutic responses.

## REFERENCES

1. Braunwald E, Antman EM, Beasley JW, et al. ACC/AHA guideline update for the management of patients with unstable angina and non-ST-segment elevation myocardial infarction: a report of the American College of Cardiology/American Heart Association Task Force on Practice Guidelines. Available online [www.acc.org/clinical/guidelines/unstable/incorporated/index.htm](http://www.acc.org/clinical/guidelines/unstable/incorporated/index.htm).
2. Bertrand ME, Simoons ML, Fox KAA, et al. Management of acute coronary syndromes without persistent ST segment elevation: Recommendations of the Task Force of the European Society of Cardiology. *Eur Heart J* 2000;21:1406–1432.

3. Pearson TA, Mensah GA, Alexander RW, et al. Markers of inflammation and cardiovascular disease: application to clinical and public health practice. *Circulation* 2003;107:499–511.
4. van der Wal AC, Becker AE, van der Loos CM, Das PK. Site of intimal rupture or erosion of thrombosed coronary atherosclerotic plaques is characterized by an inflammatory process irrespective of the dominant plaque morphology. *Circulation* 1994;89:36–44.
5. Arbustini E, Grasso M, Diegoli M, et al. Coronary atherosclerotic plaques with and without thrombus in ischemic heart syndromes: a morphologic, immunohistochemical, and biochemical study. *Am J Cardiol* 1991;68(Suppl 5):36B–50B.
6. DiSciascio G, Cowley MJ, Goudreau E, Vetrovec GW, Johnson DE. Histopathologic correlates of unstable ischemic syndromes in patients undergoing directional coronary atherectomy: in vivo evidence of thrombosis, ulceration, and inflammation. *Am Heart J* 1994;128:419–426.
7. Biasucci LM, Liuzzo G, Colizzi C, Rizzello V. Clinical use of C-reactive protein for the prognostic stratification of patients with ischemic heart disease. *Ital Heart J* 2001;2:164–171.
8. Biasucci LM, Abbate A, Liuzzo G. Prognostic role of plasma high-sensitivity C-reactive protein levels in acute coronary syndromes. In: Wu AH, ed. *Cardiac Markers*, 2nd ed. Humana, Totowa, NJ, 2003, pp. 291–303.
9. Liuzzo G, Biasucci LM, Gallimore JR, et al. The prognostic value of C-reactive protein and serum amyloid A protein in severe unstable angina. *N Engl J Med* 1994;331:417–424.
10. Yan AT, Tan M, Fitchett D, et al. One-year outcome of patients after acute coronary syndromes (from the Canadian Acute Coronary Syndromes Registry). *Am J Cardiol* 2004;94:25–29.
11. Heeschen C, van den Brand MJ, Hamm CW, Simoons ML, for the CAPTURE investigators. Angiographic findings in patients with refractory unstable angina according to troponin T status. *Circulation* 1999;104:1509–1514.
12. Hamm CW, Heeschen C, Goldmann B, et al. Benefit of abciximab in patients with refractory unstable angina in relation to serum troponin T levels. *N Engl J Med* 1999;340:1623–1629.
13. Lenderink T, Boersma E, Heeschen C, et al. Elevated troponin T and C-reactive protein predict impaired outcome for 4 years in patients with refractory unstable angina, and troponin T predicts benefit of treatment with abciximab in combination with PTCA. *Eur Heart J* 2003;24:77–85.
14. Morrow DA, Rifai N, Altman EM, et al. C-reactive protein is a potent predictor of mortality independently of and in combination with troponin T in acute coronary syndromes: a TIMI 11A substudy. *Thrombolysis in Myocardial Infarction 11A. J Am Coll Cardiol* 1998;31:1460–1465.
15. Biasucci LM, Meo A, Buffon A, et al. Independent prognostic value of C-reactive protein levels for in-hospital death and myocardial infarction in unstable angina. *Circulation* 2000;102(Suppl II):140 (Abstract).
16. Mueller C, Buettner HJ, Hodgson JM, et al. Inflammation and long-term mortality after non-ST elevation acute coronary syndrome treated with a very early invasive strategy in 1042 consecutive patients. *Circulation* 2002;105:1412–1415.
17. James SK, Armstrong P, Barnathan E, et al. Troponin and C-reactive protein have different relations to subsequent mortality and myocardial infarction after acute coronary syndrome: a GUSTO-IV substudy. *J Am Coll Cardiol* 2003;41:916–924.
18. Biasucci LM, Liuzzo G, Grillo RL, et al. Elevated levels of C-reactive protein at discharge in patients with unstable angina predict recurrent instability. *Circulation* 1999;99:855–860.
19. Lindhal B, Toss H, Siegbahn A, et al., for the FRISC Study Group. Markers of myocardial damage and inflammation in relation to long-term mortality in unstable coronary artery disease. *N Engl J Med* 2000; 343:1139–1147.
20. Heeschen C, Hamm CW, Bruemmer J, et al. for the CAPTURE Investigators. Predictive value of C-reactive protein and troponin T in patients with unstable angina: a comparative analysis. *J Am Coll Cardiol* 2000;35:1535–1542.
21. Buffon A, Liuzzo G, Biasucci LM, et al. Preprocedural serum levels of C-reactive protein predict early complications and late restenosis after coronary angioplasty. *J Am Coll Cardiol* 1999;34:1512–1521.
22. Chew DP, Bhatt DL, Robbins MA, et al. Incremental prognostic value of elevated baseline C-reactive protein among established markers of risk in percutaneous coronary intervention. *Circulation* 2001;104: 992–997.
23. Versaci F, Gaspardone A, Tomai F, et al. Predictive value of C-reactive protein in patients with unstable angina pectoris undergoing coronary artery stent implantation. *Am J Cardiol* 2000;85:92–95.
24. Walter DH, Fichtlscherer S, Sellwig M, et al. Preprocedural C-reactive protein levels and cardiovascular events after coronary stent implantation. *J Am Coll Cardiol* 2001;37:839–846.

25. Versaci F, Gaspardone A, Tomai F, et al. Immunosuppressive Therapy for the Prevention of Restenosis After Coronary Artery Stent Implantation (IMPRESS Study). *J Am Coll Cardiol* 2002;40:1935–1942.
26. Gabay C, Kushner I. Acute phase proteins and other systemic responses to inflammation. *N Engl J Med* 1999;340:448–454.
27. Biasucci LM, Vitelli A, Liuzzo G, et al. Elevated levels of interleukin-6 in unstable angina. *Circulation* 1996;94:874–877.
28. Biasucci LM, Liuzzo G, Fantuzzi G, et al. Increasing levels of interleukin (IL)-1Ra and IL-6 during the first 2 days of hospitalization in unstable angina are associated with increased risk of in-hospital coronary events. *Circulation* 1999;99:2079–2084.
29. Koukkinen H, Penttilä K, Kempainen A, et al. C-reactive protein, fibrinogen, interleukin-6 and tumor necrosis factor- $\alpha$  in the prognostic classification of unstable angina pectoris. *Ann Med* 2001;33:37–47.
30. Patti G, D'Ambrosio A, Dobrina A, et al. Interleukin-1 receptor antagonist: a more sensitive marker of instability than C-reactive protein in patients with coronary artery disease. *J Thromb Thrombolysis* 2002;14:139–143.
31. Ridker PM, Rifai N, Pfeffer M, et al. Elevation of tumor necrosis factor-alpha and increased risk of recurrent coronary events after myocardial infarction. *Circulation* 2000;101:2149–2153.
32. Abbate A, Vecile E, Fiotti N, et al. Plasma concentrations of interleukin-2 soluble receptor in mild ischaemic left ventricular dysfunction. *Eur J Heart Fail* 2003;5:23–25.
33. Patti G, Di Sciascio G, D'Ambrosio A, Dicuonzo G, Abbate A, Dobrina A. Prognostic value of interleukin-1 receptor antagonist in patients undergoing percutaneous coronary intervention. *Am J Cardiol* 2002;89:372–376.
34. Blankenberg S, Tiret L, Bickel C, et al. Interleukin-18 is a strong predictor of cardiovascular death in stable and unstable angina. *Circulation* 2002;105:143–149.
35. Patti G, D'Ambrosio A, Mega S, et al. Early interleukin-1 receptor antagonist elevation in patients with acute myocardial infarction. *J Am Coll Cardiol* 2004;43:35–38.
36. Wallen NH, Held C, Rehnqvist N, Hjemdhal P. Elevated serum intercellular adhesion molecule-1 and vascular adhesion molecule-1 among patients with stable angina pectoris who suffer cardiovascular death or non-fatal myocardial infarction. *Eur Heart J* 1999;20:1039–1043.
37. Mulvihill NT, Foley JB, Murphy RT, Curtin R, Crean PA, Walsh M. Risk stratification in unstable angina and non-Q wave myocardial infarction using soluble cell adhesion molecules. *Heart* 2001;85:623–627.
38. Liuzzo G, Kopecky SL, Frye RL, et al. Perturbation of the T-cell repertoire in patients with unstable angina. *Circulation* 1999;100:2135–2139.
39. Liuzzo G, Goronzy JJ, Yang H, et al. Monoclonal T-cell proliferation and plaque instability in acute coronary syndromes. *Circulation* 2000;101:2883–2888.
40. Spagnoli LG, Bonanno E, Mauriello A, et al. Multicentric inflammation in epicardial coronary arteries of patients dying of acute myocardial infarction. *J Am Coll Cardiol* 2002;40:1579–1588.
41. Neri Serneri GG, Boddi M, Modesti PA, et al. Immunomediated and ischemia-independent inflammation of coronary microvessels in unstable angina. *Circ Res* 2003;92:1359–1366.
42. Abbate A, Bonanno E, Mauriello A, et al. Widespread myocardial inflammation and infarct-related artery patency. *Circulation* 2004;110:46–50.
43. Avanzas P, Arroyo-Espiguero R, Cosin-Sales J, et al. Markers of inflammation and multiple complex stenoses (pancoronary plaque vulnerability) in patients with non-ST segment elevation acute coronary syndromes. *Heart* 2004;90:847–852.
44. Lombardo A, Biasucci LM, Lanza G, et al. Inflammation as a possible link between coronary and carotid plaque instability. *Circulation* 2004;109:3158–3163.
45. Biasucci LM, Liuzzo G, Ciervo A, et al. Antibody response to chlamydial heat shock protein 60 is strongly associated with acute coronary syndromes. *Circulation* 2003;107:3015–3017.
46. Liuzzo G, Buffon A, Biasucci LM, et al. Enhanced inflammatory response to coronary angioplasty in patients with severe unstable angina. *Circulation* 1998;98:2370–2376.
47. Pasceri V, Willerson JT, Yeh RTH. Direct pro-inflammatory effect of CRP on human endothelial cells. *Circulation* 2000;102:2165–2168.
48. Pasceri V, Chang J, Willerson JT, Yeh RTH. Modulation of CRP mediated monocyte chemo-attractant protein-1 in human endothelial cells by anti-atherosclerosis drugs. *Circulation* 2001;103:2531–2534.
49. Liuzzo G, Colussi C, Ginnetti F, et al. Direct activation of the transcription factor NF- $\kappa$ B by C-reactive protein in human monocytes: a clue to the inflammatory component of acute coronary syndromes? *Circulation* 2001;104(abstr suppl):168.

50. Cermak J, Key NS, Bach RR, Balla J, Jacob HS, Vercellotti GM. C-reactive protein induces human peripheral blood monocytes to synthesize tissue factor. *Blood* 1993;82:513–520.
51. Devaraj S, Xu DJ, Jialal I. C-reactive protein increases plasminogen activator inhibitor-1 expression and activity in human aortic endothelial cells: implications for the metabolic syndrome and atherothrombosis. *Circulation* 2003;107(3):398–404.
52. Danenberg HD, Szalai AJ, Swaminathan RV, et al. Increased thrombosis after arterial injury in human C-reactive protein transgenic mice. *Circulation* 2003;108(5):512–515.
53. Wang Q, Zhu X, Xu Q, Ding X, Chen YE, Song Q. Effect of C-reactive protein on gene expression in vascular endothelial cells. *Am J Physiol Heart Circ Physiol* 2005;288:H1539–H1545.
54. Bhatt DL, Topol E. Need to test the arterial inflammation hypothesis. *Circulation* 2002;106:136–140.
55. Ridker PM, Cannon CP, Morrow DA, et al. C-reactive protein levels and outcomes after statin therapy. *N Engl J Med* 2005;352:20–28.
56. Anzai T, Yoshikawa T, Shiraki H, et al. C-reactive protein as a predictor of infarct expansion and cardiac rupture after a first Q-wave acute myocardial infarction. *Circulation* 1997;96:778–784.
57. Pietila KO, Harmoinen AP, Jokiniitty J, Pasternak AI. Serum C-reactive protein concentration in acute myocardial infarction and its relationship to mortality during 24 months of follow-up in patients under thrombolytic treatment. *Eur Heart J* 1996;17:1345–1349.
58. Patti G, Di Sciascio G, D'Ambrosio A, Dicuonzo G, Abbate A, Dobrina A. Inflammatory markers and coronary interventions: a potentially useful follow-up modality after stenting. *Catheter Cardiovasc Intervent* 2002;56:341–345.
59. Solomon DH, Karlson EW, Rimm EB, et al. Cardiovascular morbidity and mortality in women diagnosed with rheumatoid arthritis. *Circulation* 2003;107:1303–1307.
60. Baldus S, Heeschen C, Meinertz T, Zeiher AM, Eiserich JP, Munzel T, Simoons ML, Hamm CW, for the CAPTURE investigators. Myeloperoxidase serum levels predict risk in patients with acute coronary syndromes. *Circulation* 2003;108:1440–1445.
61. Bazzino O, Ferreiros ER, Pizarro R, Corrado G. C-reactive protein and the stress tests for the risk stratification of patients recovering from unstable angina pectoris. *Am J Cardiol* 2001;87:1235–1239.
62. Benamer H, Steg PG, Benessiano J, et al. Comparison of the prognostic value of C-reactive protein and troponin I in patients with unstable angina pectoris. *Am J Cardiol* 1998;82:845–850.
63. Bholasingh R, Cornel JH, Kamp O, et al. The prognostic value of markers of inflammation in patients with troponin T-negative chest pain before discharge from the emergency department. *Am J Med* 2003;115:521–528.
64. Bodi V, Sanchis J, Llacer A, et al. Risk stratification in non-ST elevation acute coronary syndromes: predictive power of troponin I, C-reactive protein, fibrinogen and homocysteine. *Int J Cardiol* 2005;98:277–283.
65. de Winter RJ, Bholasingh R, Lijmer JG, et al. Independent prognostic value of C-reactive protein and troponin I in patients with unstable angina or non-Q-wave myocardial infarction. *Cardiovasc Res* 1999;42:240–245.
66. Ferreiros ER, Boissonnet CP, Pizarro R, et al. Independent prognostic value of elevated C-reactive protein in unstable angina. *Circulation* 1999;100:1958–1963.
67. Oltrona L, Ardissino D, Merlini PA, Spinola A, Chiodo F, Pezzano A. C-reactive protein elevation and early outcome in patients with unstable angina. *Am J Cardiol* 1997;80:1002–1006.
68. Oltrona L, Ottani F, Galvani M, for the Italian Working Group on Atherosclerosis, Thrombosis, and Vascular Biology and the Associazione Nazionale Medici Cardiologi Ospedalieri (ANMCO). Clinical significance of a single measurement of troponin-I and C-reactive protein at admission in 1773 consecutive patients with acute coronary syndromes. *Am Heart J* 2004;148:405–415.
69. Rebuzzi AG, Quaranta G, Liuzzo G, et al. Incremental prognostic value of serum levels of troponin T and C-reactive protein on admission in patients with unstable angina pectoris. *Am J Cardiol* 1998;82:715–719.
70. Sanchez PL, Morinigo JL, Pabon P, et al. Prognostic relations between inflammatory markers and mortality in diabetic patients with non-ST elevation acute coronary syndromes. *Heart* 2004;90:264–269.
71. Toss H, Lindhal B, Siegbahn A, Wallentin L. Prognostic influence of increased fibrinogen and C-reactive protein levels in unstable coronary artery disease. FRISC Study Group. *Circulation* 1997;96:4204–4210.
72. Zebrack JS, Anderson JL, Maycock CA, Horne BD, Bair TL, Muhlestein JB, for the Intermountain Heart Collaborative (IHC) Study Group. Usefulness of high-sensitivity C-reactive protein in predicting long-term risk of death or acute myocardial infarction in patients with unstable or stable angina pectoris or acute myocardial infarction. *Am J Cardiol* 2002;89:145–149.



# 18

---

## Beyond C-Reactive Protein

### *Novel Markers of Vascular Inflammation*

---

*Christopher Heeschen, MD*

#### CONTENTS

INTRODUCTION

NOVEL BIOCHEMICAL MARKERS OF VASCULAR INFLAMMATION

CONCLUSION

REFERENCES

---

#### SUMMARY

The combined use of markers reflecting distinct pathophysiological features, namely myocardial necrosis, vascular inflammation, oxidative stress, and neurohumoral activation, may significantly add to the ability to identify correctly patients who are at high risk of short- and long-term cardiovascular events. Elevations in C-reactive protein, an acute-phase protein released in response to any proinflammatory stimulus, in patients with acute coronary syndrome (ACS) are closely related to the presence of myocardial injury, as evidenced by elevations in troponin. Accordingly, in a large number of patients with ACS, an acute inflammatory process induced by myocardial damage is superimposed on a chronic inflammatory condition, both of which might influence long-term outcome in unstable coronary artery disease. Novel inflammatory markers such as placental growth factor and pregnancy-associated plasma protein-A show a stronger association with vascular inflammation and appear to be more closely related to the short-term risk of patients with ACSs. It has also been shown that soluble CD40 ligand is a powerful biochemical marker of thrombotic inflammatory activation in patients with ACS, supporting the close relationship among inflammation, thrombotic activation, and ACSs. Individuals with biochemical evidence for inflamed and unstable atherosclerotic plaque formation, even prior to the occurrence of minor myocardial injury, may benefit most from an aggressive medical regimen and an early invasive strategy.

**Key Words:** Troponin; soluble CD40 ligand; placental growth factor; pregnancy-associated plasma protein; myeloperoxidase.

#### INTRODUCTION

Coronary artery disease (CAD) spans a wide spectrum of conditions, ranging from the extreme of low-risk chronic stable angina to acute myocardial infarction (AMI) or sudden death. Unstable angina is a transitory phase bordering on MI. However, unstable angina

From: *Contemporary Cardiology:  
Cardiovascular Biomarkers: Pathophysiology and Disease Management*  
Edited by: David A. Morrow © Humana Press Inc., Totowa, NJ



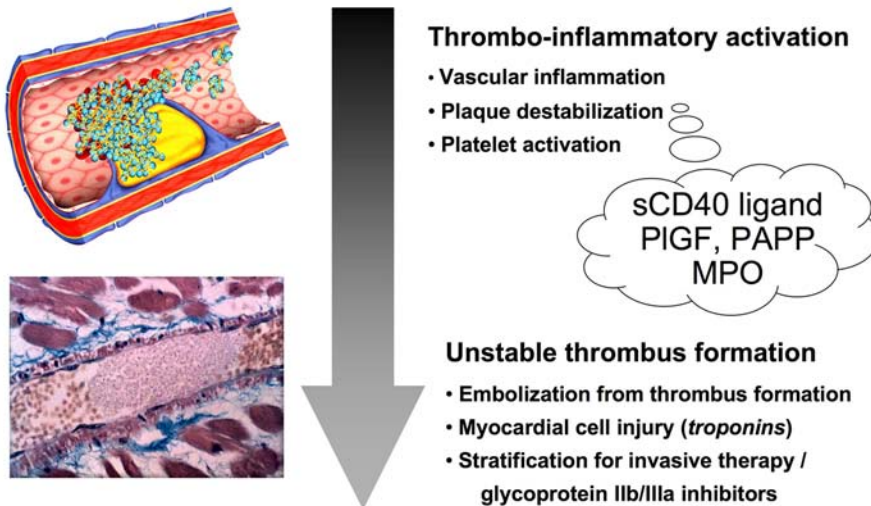
is a clinically defined, heterogeneous syndrome with widely variable symptoms and prognosis. Studies conducted in the 1960s and 1970s showed rates of major adverse clinical events (death and nonfatal MI) ranging from 10% at 3 mo to 17% at 24 mo. Even to date, the prognosis of patients with acute coronary syndrome (ACS) remains unfavorable. In the EuroHeartSurvey conducted from September 2000 to May 2001 in 103 tertiary and community centers from 25 member countries of the European Society of Cardiology, the 6-mo mortality of ACSs without ST-segment elevation was 12% (1). This rate was similar to the event rate observed in the GRACE survey (2). However, the results of recent clinical trials indicate that a diagnostic and therapeutic strategy including careful risk stratification in conjunction with novel therapeutic agents and revascularization in adequately selected patients will ultimately help to improve both immediate and long-term outcome of patients with ACS.

### NOVEL BIOCHEMICAL MARKERS OF VASCULAR INFLAMMATION

Biochemical markers not only have contributed to a better understanding of the underlying pathophysiological mechanisms of ACSs but have also improved the evaluation of patients with acute chest pain who are suspected of having an ACS. For many years, unstable angina has been considered an intermediate “syndrome” between chronic stable angina and AMI. However, the pathophysiology of the ACS has now been clarified, with concurrent major advances in its management. The current pathophysiological concept describes ACSs as being related to an acute or a subacute primary reduction in myocardial oxygen supply that is provoked by disruption of an atherosclerotic plaque associated with thrombosis, vasoconstriction, and microembolization. Convincing evidence suggests that both inflammatory and thrombotic mechanisms are involved in the pathogenesis of ACSs (3,4). Inflammatory reactions promote plaque fissuring or erosion, which exposes thrombogenic contents such as collagen to the circulation, followed by platelet activation and platelet adhesion. It is now apparent that ACSs, namely unstable angina and evolving MI, share a common anatomic substrate: pathological, angioscopic, and biological observations have demonstrated that unstable angina and MI are only different clinical presentations that result from a common underlying pathophysiological mechanism—atherosclerotic plaque rupture or erosion—with differing degrees of superimposed thrombosis and distal embolization (Fig. 1) (2,5).

Elevated levels of circulating cardiac troponin, a marker of myocardial necrosis, are found in about one-third of patients with ACS and are associated with an increased short-term risk of death and nonfatal MI (6–9). Although the absolute short-term risk of troponin-negative patients is significantly lower compared with troponin-positive patients, the large number of patients without troponin elevation remains clinically challenging with respect to risk assessment and therapeutic management. Specifically, the 6-mo risk of death or nonfatal MI in troponin-negative patients was 8.4% in the CAPTURE (c7E3 Anti Platelet Therapy in Unstable Refractory angina) trial (10). Therefore, the availability of a sensitive and specific early marker of plaque instability, wherein levels become elevated before or even in the absence of myocardial necrosis, should improve diagnostic and therapeutic decision making.

Of the numerous inflammatory markers that have been investigated over the past decade, C-reactive protein (CRP) is clearly the most widely studied. There is compelling epidemiological evidence that CRP is a sensitive marker of inflammation and/or metabolic processes associated with atherogenesis and the occurrence of cardiovascular events. Although



**Fig. 1.** Earlier markers of vascular inflammatory and thromboinflammatory activation, respectively, may precede the development of myocardial injury (troponin release) or neurohumoral activation (B-type natriuretic peptide [BNP] or NT-proBNP release) in patients with ACS.

CRP has been shown to be useful for risk assessment in different cohorts (11–13), the debate as to whether or not CRP is indeed a clinically useful biomarker continues. The data that Danesh et al. (13) reported derived from the Reykjavik prospective cohort study, which included 2459 patients with stable coronary heart disease and 3969 selected control subjects, suggested that the predictive value of a single baseline measurement of CRP for the 20-yr incidence of cardiovascular events was much less impressive than in previously published data (14,15). They found that CRP adds little to the predictive value provided by the assessment of traditional risk factors, including low-density lipoprotein (LDL) cholesterol. By contrast, Ridker et al. (16) previously reported that CRP could be even more predictive than LDL. Since the Reykjavik study included by far the largest number of events (albeit during a rather long follow-up period of 20 yr) that have been studied in such analyses, the new findings emphasize the need for more research to clarify the use of CRP as a marker of cardiovascular risk in clinical practice. Specifically, future studies will have to reliably characterize the shape of the relationship between CRP values and coronary risk as well as to investigate the use of CRP for risk prediction in particular subgroups (e.g., in those with different serum lipid concentrations and for different periods of follow-up).

In patients with ACSs, elevated levels of CRP are associated with higher future risk of cardiovascular events (17–19). The CAPTURE trial investigators found that, although only troponin T was predictive in the initial 72-h period, CRP was an independent predictor of cardiovascular risk at 6 mo (19). Investigators of the FRISC study, the TIMI 11A sub-study, and the GUSTO IV sub-study also reported that the risk associated with elevated CRP levels at the time of the index event continues to increase during follow-up (18,20,21). More important, however, the exact source of elevated CRP levels among patients with unstable coronary syndromes remains unclear. Given that myocardial damage is also a major inflammatory stimulus, it is important to note that in a recent combined analysis of FRISC-II and GUSTO-IV, CRP elevation over a period of up to 120 h after the onset of

symptoms was found only in patients with elevated troponin levels (21). Consistently, in CAPTURE patients, CRP levels were significantly higher in troponin-positive patients (19), suggesting that an acute inflammatory process induced by myocardial damage is superimposed on a chronic inflammatory condition, both of which might influence long-term outcome in unstable CAD.

Type 2 secretory phospholipase A<sub>2</sub> (sPLA<sub>2</sub>) is also an acute-phase reactant, which accumulates in atherosclerotic arterial walls, elicits several effects on monocytes, and provides a link between inflammation and lipid accumulation in atherosclerotic plaques. sPLA<sub>2</sub> is present in the media of normal as well as diseased arteries, hydrolyzes phospholipids, and contributes to the production of oxidized LDL, which is taken up by macrophages, resulting in enhanced transformation into foam cells. sPLA<sub>2</sub> exhibits features similar to those of CRP as a marker of plaque inflammation as well as endothelial dysfunction (22,23) and may predict coronary events independently of other risk factors in patients with unstable angina (24). Similarly, elevated levels of the lipoprotein-associated PLA<sub>2</sub> (Lp-PLA<sub>2</sub>), a different approach to determine PLA<sub>2</sub> activation, have been shown to predict future coronary events in apparently healthy middle-aged men with moderately elevated total cholesterol, independent of CRP (25). No data on the predictive value of Lp-PLA<sub>2</sub> in patients with ACS have been published to date.

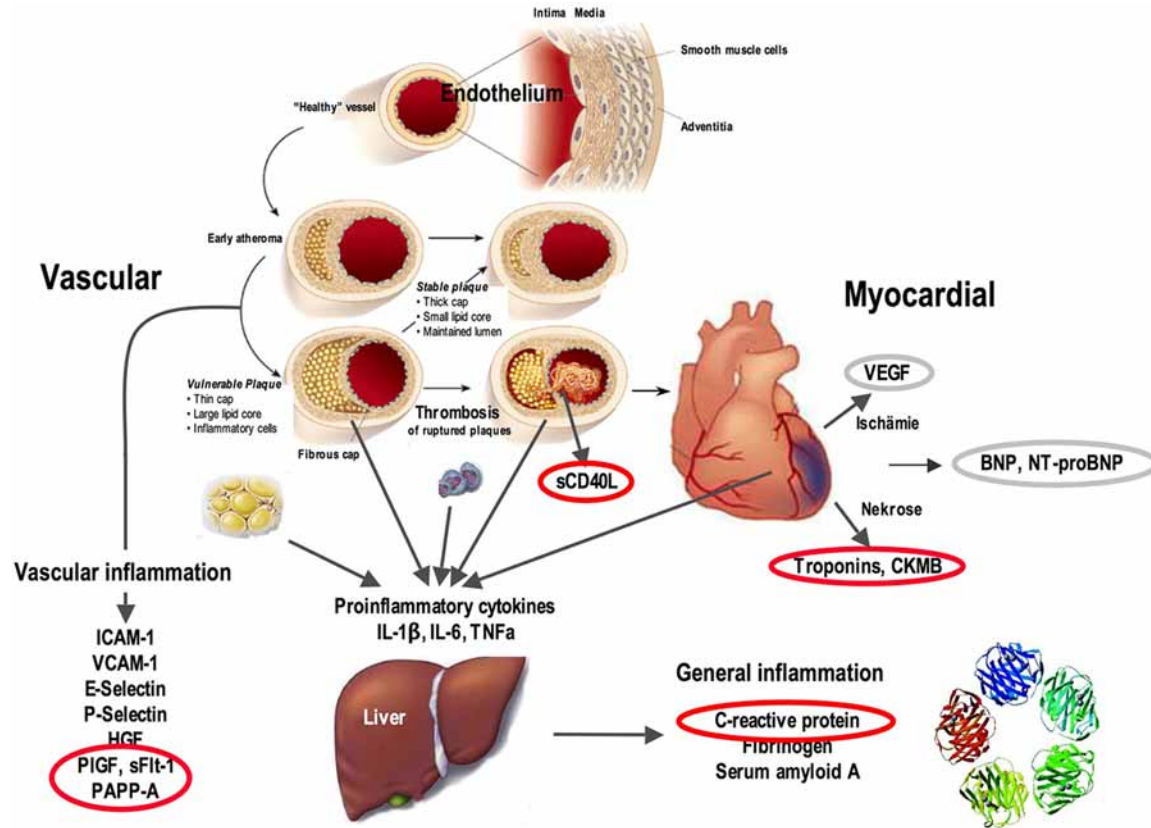
Therefore, as a result of lack of specificity of acute-phase proteins for detecting the underlying vascular inflammation in patients with ACS, research activities have shifted to the identification of more upstream markers of the inflammatory cascade, which may be more representative of vascular inflammation (Fig. 2). These novel inflammatory markers include pregnancy-associated plasma protein A (PAPP-A), placental growth factor (PIGF), soluble CD40 ligand (sCD40L), and myeloperoxidase (MPO).

### *PAPP-A as a Marker for Plaque Stability*

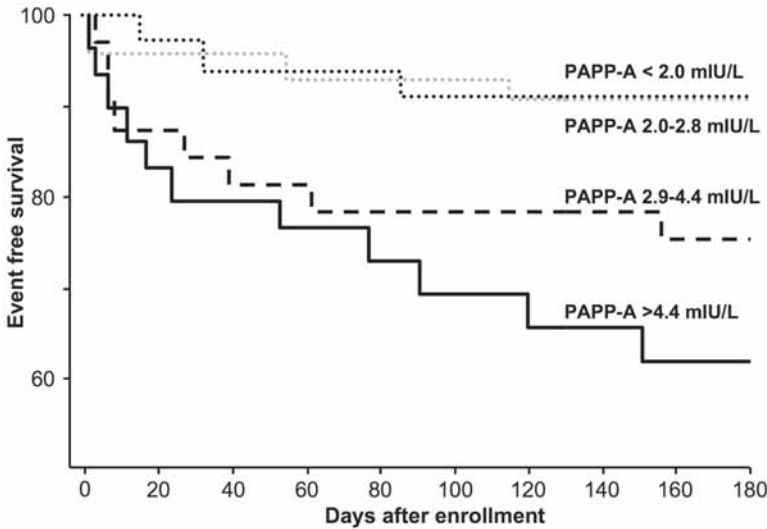
The progression and destabilization of atheromatous plaques involve major changes in the structure of the arterial wall. Matrix metalloproteinases (MMPs) are potential indicators of arterial inflammation, and by degrading extracellular matrix, they contribute to the fragility of the lipid-rich, atherosclerotic plaque and finally to its rupture. PAPP-A is a high-molecular-weight, zinc-binding MMPs enzyme that is measured during pregnancy in maternal blood for the fetal diagnosis of Down syndrome. However, low levels of circulating PAPP-A are also physiologically present in both men and women. As previously described for several other MMPs (MMP-1, MMP-3, MMP-12, or MMP-13) (26, 27), data from patients with ACS also indicate the presence of PAPP-A in atherosclerotic plaques (28). Among patients who died suddenly from cardiac causes, PAPP-A was abundantly expressed in ruptured and eroded unstable plaques, but PAPP-A was absent or minimally expressed in stable plaques (28). In plaques with large lipid cores and cap rupture, staining for PAPP-A revealed that the enzyme occurred mostly in the inflammatory shoulder region. PAPP-A is a specific activator of insulin-like growth factor-1, a mediator of atherosclerosis, and has been implicated in coronary plaque disruption (29).

With respect to the prognostic impact of elevated PAPP-A levels in patients with ACS, a recent study suggests that measurement of plasma PAPP-A is an independent predictor of ischemic cardiac events and the need for revascularization in patients who present with suspected MI but remain troponin negative (Fig. 3) (30).

The endogenous inhibitor of PAPP-A, the proform of eosinophil major basic protein (proMBP), may also play an important role in the pathophysiology of ACSs. Indeed,



**Fig. 2.** Pathophysiology of atherosclerosis with respect to lesion development, progression, and destabilization. A variety of biomarkers with distinct pathophysiological profiles can be used to assess disease activity. ICAM-1, intracellular adhesion molecule-1; VCAM-1, vascular cell adhesion molecule-1; HGF, hepatocyte growth factor; CKMB, creatine kinase-MB.



**Fig. 3.** Predictive value of PAPP-A in patients with ACS. Kaplan-Meier curves of event-free survival for the combined end points cardiovascular death, MI, and revascularization according to PAPP-A groups ( $n = 136$ ) are shown.

**Table 1**  
**Multivariable Analysis for Prediction of Combined End Points Cardiovascular Death, MI, and Revascularization According to PAPP-A Groups ( $n = 136$ )**

Variable	$r$	$p$	$B$ (95% CI) <sup>a</sup>	$\beta$ <sup>b</sup>	$p$
Age	0.22	<0.001	0.016 (0.003–0.028)	0.11	0.015
Male gender	0.38	<0.001	0.54 (0.28–0.80)	0.19	<0.001
⊕75% Stenosis <sup>c</sup>	0.59	<0.001	0.58 (0.46–0.69)	0.46	<0.001
PAPP-A/proMBP ratio <sup>d</sup>	0.23	<0.001	0.39 (0.05–0.72)	0.10	0.026

<sup>a</sup>Increment in the number of complex lesions with every unit of the independent variable.

<sup>b</sup>The  $\beta$  value corresponds to the standardized multiple regression coefficient.

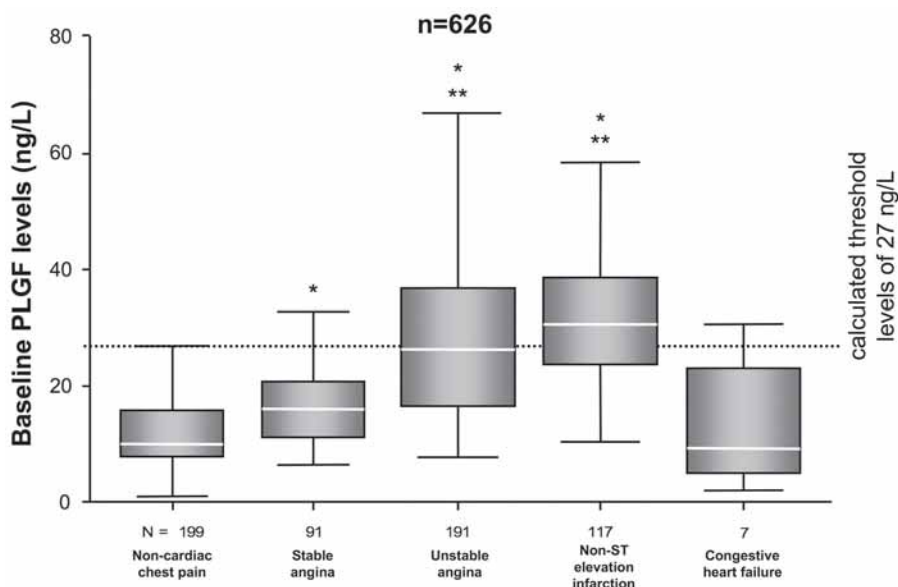
<sup>c</sup>Number of main coronary arteries with a ⊕75% stenosis.

<sup>d</sup>Logarithm-transformed PAPP-A/proMBP ratio levels.

Cosin-Sales et al. (31) reported that among patients with stable angina, those with more complex coronary stenoses had a significantly higher PAPP-A/proMBP ratio and PAPP-A levels than those without complex stenoses. Multivariable regression analysis indicated that gender, age, severe coronary artery disease (CAD), and PAPP-A/proMBP ratio, but not high-sensitivity CRP (hsCRP) levels, were independently associated with the number of angiographically complex stenoses (Table 1). Thus, PAPP-A and its endogenous inhibitor proMBP are both promising candidates for risk stratification but require validation in larger cohorts.

***PIGF as a Primary Vascular Inflammatory Instigator***

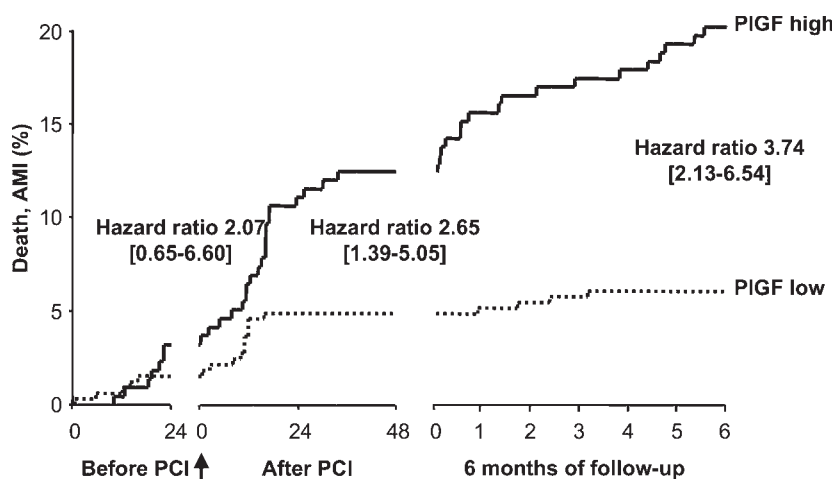
PIGF, a member of the vascular endothelial growth factor (VEGF) family of growth factors, was recently shown to be profoundly upregulated in early and advanced atherosclerotic lesions (32). Originally identified in the placenta (33), PIGF stimulates vascular smooth muscle growth, recruits macrophages into atherosclerotic lesions, upregulates



**Fig. 4.** PIGF levels in patients with acute chest pain presenting to emergency rooms. Patients were categorized according to their final diagnosis at the time of discharge. \*,  $p < 0.01$  vs non-cardiac chest pain; \*\*,  $p < 0.01$  vs stable angina.

tumor necrosis factor- $\alpha$  (TNF- $\alpha$ ) and monocyte chemoattractant protein-1 production by macrophages, enhances production of tissue factor, and stimulates pathological angiogenesis (32,34). All these processes are known contributors to plaque progression and destabilization. Most important, however, inhibition of the effects of PIGF by blocking its receptor Flt-1 was experimentally shown to suppress both atherosclerotic plaque growth and vulnerability via inhibition of inflammatory cell infiltration (32). These data suggest that PIGF may act as a primary inflammatory instigator of atherosclerotic plaque instability. Indeed, PIGF serum levels are markedly upregulated in patients with ACS independent of the presence of myocardial injury (Fig. 4) (35). Moreover, data from the CAPTURE trial established PIGF blood levels as a novel, powerful, independent prognostic determinant of clinical outcome in patients with ACS (Fig. 5) (35). The predictive value of PIGF levels is independent of myocardial necrosis, as evidenced by elevated troponin levels (36), as well as platelet activation, as evidenced by elevation of sCD40L (37). Intriguingly, elevated PIGF levels identified not only those patients with acute chest pain with ACS, but also those patients who had an increased risk of recurrent instability from an initial ACS after discharge. Thus, measuring PIGF levels may represent not only a reliable and powerful clinical tool for identifying patients with high-risk lesion formation, but also those with ongoing vascular inflammation of the coronary circulation.

The role of PIGF as a primary inflammatory instigator of atherosclerotic lesion instability can be substantiated by its well-documented proinflammatory effects in animal models of atherosclerosis or arthritis (32). Although PIGF belongs to the family of VEGF, its etiopathogenetic role appears to be related more to vascular inflammation than to angiogenesis (32). Indeed, whereas VEGF is activated by hypoxia and elevation in VEGF levels is regarded as an early adaptation of the myocardium to deprivation of blood flow (38), PIGF is not affected or even downregulated by hypoxia (39,40). In line with these data, analysis of the CAPTURE data did not reveal any correlation between PIGF levels and VEGF



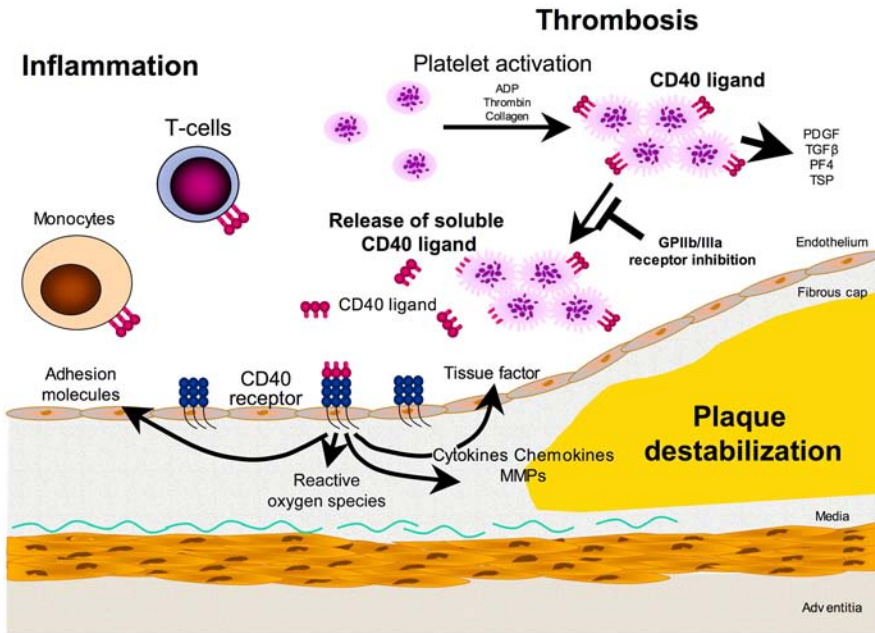
**Fig. 5.** Predictive value of PIGF in patients with ACS. The cumulative incidence of death or nonfatal MI at 72 h and 6 mo of follow-up by baseline PIGF levels in CAPTURE patients receiving placebo treatment ( $n = 547$ ) is shown. PCI, percutaneous coronary intervention.

levels as a marker of myocardial ischemia or between PIGF levels and troponin levels as a marker of myocardial necrosis. Thus, PIGF levels do not appear to be confounded by myocardial necrosis, whereas VEGF levels are linked to troponin elevation, impaired TIMI flow, and clinical evidence of myocardial ischemia (41). Lack of PIGF-level sensitivity to minor myocardial injury might be particularly important in patients with ACS, of whom approximately one-third are positive for troponin at the time of arrival in the hospital (42).

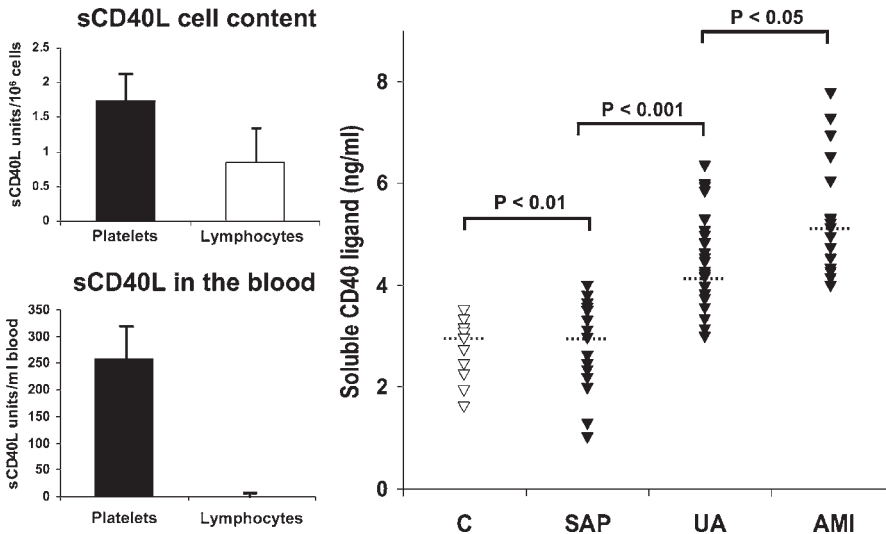
In summary, PIGF plasma levels represent a powerful and reliable clinical biomarker of vascular inflammation and adverse outcome in patients with ACS. Measuring PIGF levels significantly extends the predictive and prognostic information gained from traditional inflammatory markers in ACS. Most notably, because the proinflammatory effects of PIGF can be specifically inhibited by blocking its receptor Flt-1, these findings may also provide a rationale for a novel anti-inflammatory therapeutic target in patients with CAD (43).

### *sCD40L as a Marker for Platelet Activation*

Plaque rupture induces platelet activation through the liberation of collagen, thrombin, and adenosine 5'-diphosphate (ADP) (Fig. 6). Platelet activation results in an increased surface expression of CD40L, which subsequently is cleaved from the membrane surface. The released sCD40L can activate CD40 on endothelial cells and thereby induce a pro-inflammatory cascade in the vessel wall. Moreover, sCD40L can activate CD40, which is also expressed on inflammatory cells such as monocytes and T-cells. The subsequent activation of these inflammatory cells and their invasion into the ruptured or eroded plaque results in a further inflammatory perturbation of the vessel wall. In patients with coronary heart disease, sCD40L is primarily released from activated platelets, and subsequently elevated levels have been reported for patients with ACS (Fig. 7) (44,45). Moreover, two studies (37,46) have consistently shown that sCD40L is a powerful biochemical marker of thrombotic inflammatory activation (Fig. 8) in patients with ACS, supporting the close relationship among inflammation, thrombotic activation, and ACSs. Furthermore, both studies have clearly demonstrated that combining this new marker with clas-



**Fig. 6.** Pathophysiological role of sCD40L in plaque destabilization and thrombosis of patients with ACS. PDGF, platelet-derived growth factor; TGFβ, transforming growth factor B; PF4, platelet factor 4; TSP, thrombospondin.

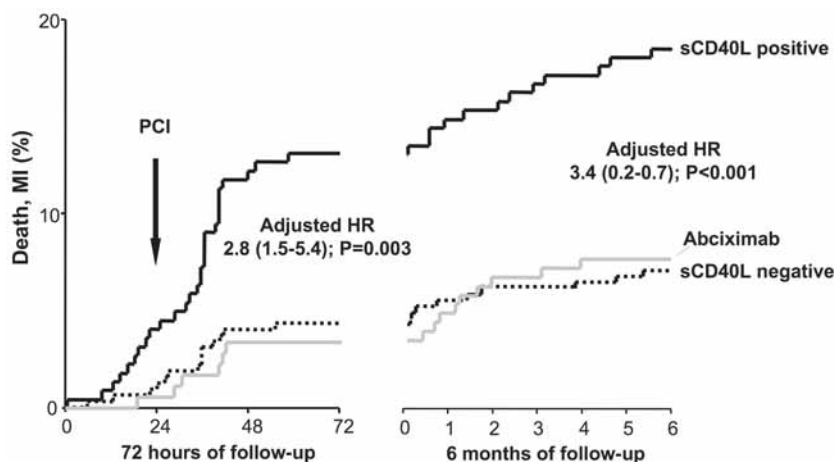


**Fig. 7.** sCD40L levels are primarily released from platelets (A) and are elevated in patients with ACS (B). C, control; SAP, stable angina pectoris; UA, unstable angina; AMI, acute myocardial infarction.

sis markers of necrosis (troponins) can help to identify patients at the highest risk of subsequent cardiovascular events.

More important, blockade of the glycoprotein IIb/IIIa receptor on platelets inhibits the release of sCD40L through inhibition of platelet aggregation via fibrinogen. It has been shown that levels of sCD40L not only identify patients with ACS who are at highest risk



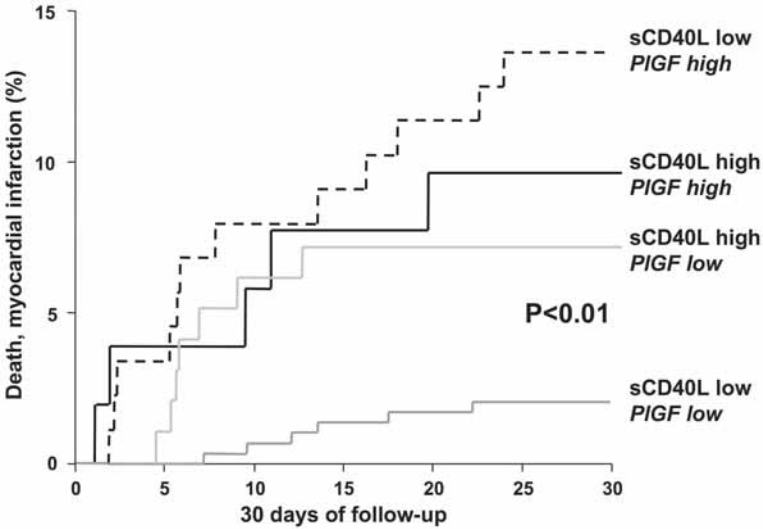


**Fig. 8.** Predictive value of sCD40L in patients with ACSs. The cumulative incidence of death or non-fatal MI at 72 h and 6 mo of follow-up by baseline sCD40L levels in CAPTURE patients receiving placebo treatment ( $n = 544$ ) is shown. The increased risk of patients with elevated sCD40L levels was abrogated by treatment with the glycoprotein IIb/IIIa inhibitor abciximab. HR, hazard ratio; PCI, percutaneous coronary intervention.

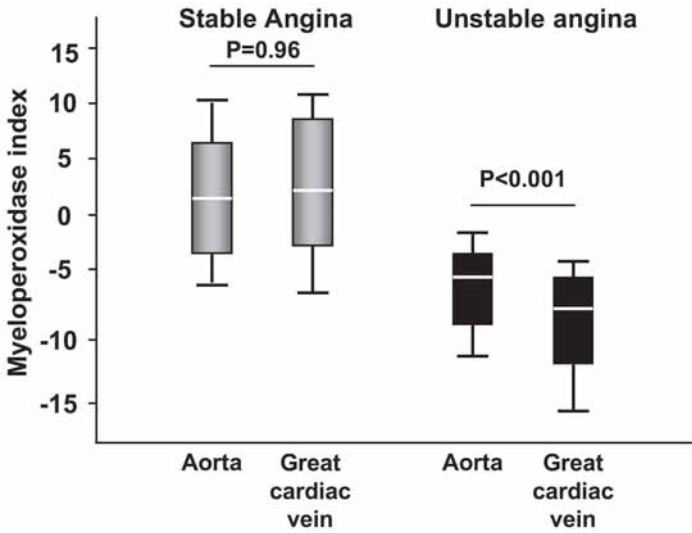
of ischemic events but also predict which patients will derive major benefit from anti-platelet treatment with the glycoprotein IIb/IIIa receptor antagonist abciximab (Fig. 8) (37). By multivariate logistic regression analysis, PIGF, sCD40L, and troponin all emerged as independent predictors of adverse outcome. Combining PIGF and sCD40L was especially revealing in patients with chest pain negative for troponin, suggesting that both markers reflect distinct pathways, which eventually contribute to a proinflammatory and procoagulant milieu in the coronary circulation (Fig. 9). Supportive of a complementary rather than competing role in predicting adverse outcome in patients with ACS were the findings that aggressive inhibition of platelet aggregation by the glycoprotein IIb/IIIa inhibitor abciximab was specifically useful in patients with elevated sCD40L levels. Given PIGF's superiority to hsCRP in patients with ACS, the identification of PIGF as a primary inflammatory instigator of coronary lesion instability as well as the use of sCD40L as a marker for platelet activation may significantly enhance the diagnostic armamentarium for the diagnosis and risk stratification of patients with ACS.

### *MPO as a Marker for Oxidative Stress*

There is growing evidence that myocardial cell injury is not only related to platelet activation but also preceded by recruitment and activation of leukocytes, most notably polymorphonuclear neutrophils (47–49). Polymorphonuclear neutrophils have been shown to increasingly undergo degranulation within the coronary circulation in ACSs (Fig. 10) (48). One of the principal mediators secreted on degranulation of polymorphonuclear neutrophils is MPO, a hemoprotein traditionally viewed as a microbicidal enzyme (50). There is accumulating evidence that MPO displays potent proatherogenic properties. For example, MPO can oxidize LDL cholesterol, thereby propagating uptake by macrophages and perpetuating foam cell formation (51). Furthermore, MPO has been shown to activate metalloproteinases and promote destabilization and rupture of the atherosclerotic plaque surface (52). In addition, MPO catalytically consumes endothelial-derived nitric oxide

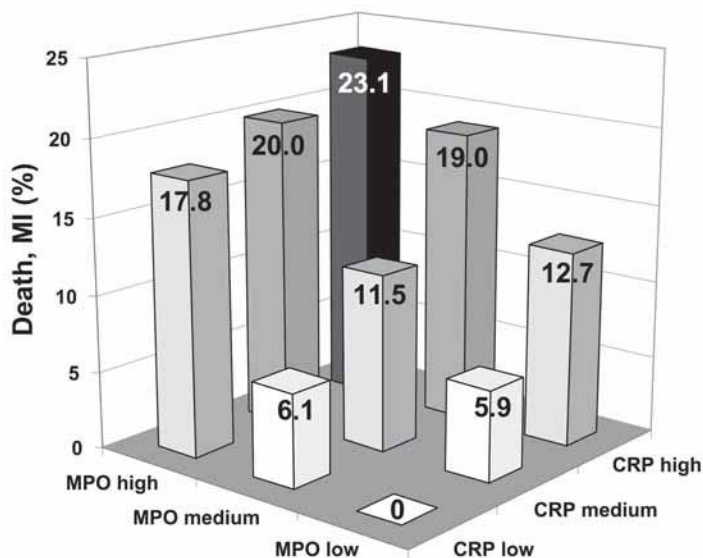


**Fig. 9.** Multimarker approach. The results of the combined use of PIGF and sCD40L for risk stratification of patients with acute chest pain and troponin T levels  $<0.01 \mu\text{g/L}$  with respect to death or non-fatal AMI during 30 d of follow-up ( $n = 531$ ) are shown.



**Fig. 10.** Neutrophil activation is indicated by the change in the MPO index in blood from the aorta and great cardiac vein. In patients with unstable angina, but not in patients with stable angina, a decrease in MPO content was observed in blood from the great cardiac vein, not only when the neutrophils traversed the coronary vascular bed perfused by the culprit stenosis and thus subjected to recurrent ischemia (unstable angina with a left coronary lesion), but also when there was no coronary stenosis or any plausible cause of ischemia in the vascular bed draining into the great cardiac vein (unstable angina with a right coronary lesion).

(NO), thereby reducing NO bioavailability and impairing its vasodilatory and antiinflammatory functions (53,54). Two recent studies have also revealed that MPO is strongly associated with adverse outcome in patients with ACS (55,56). Particularly in individuals with low troponin levels, MPO identified patients at increased risk for early cardiovascular events that occur within days after the onset of symptoms (Fig. 11) (55). This suggests



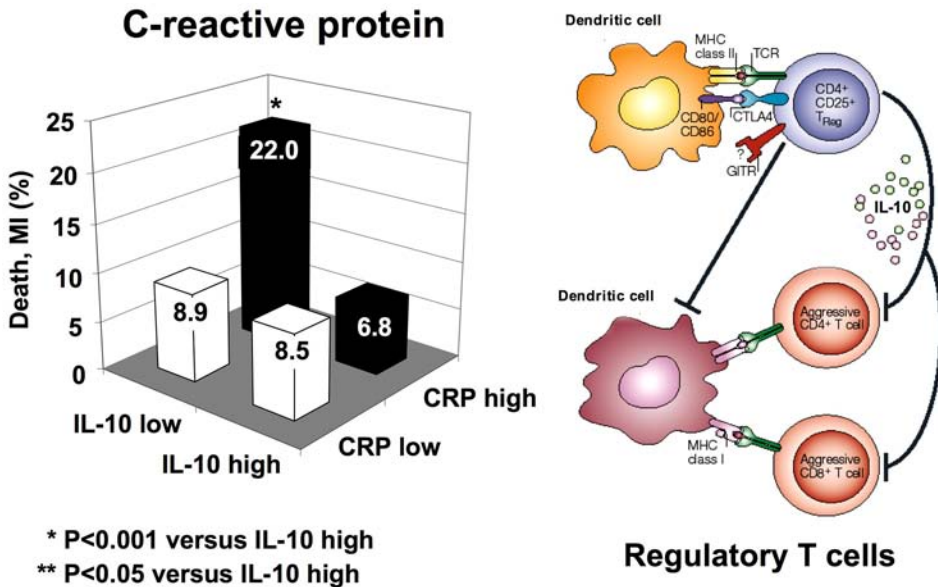
**Fig. 11.** Predictive value of MPO for incidence of death and nonfatal MI in relation to CRP serum levels. Diagnostic threshold levels were 222 and 350  $\mu\text{g/L}$  for MPO and 5 and 15  $\text{mg/L}$  for CRP ( $n = 547$ ). MI indicates nonfatal MI.

that MPO unmasks states of acute inflammation in the coronary circulation indicative of increased neutrophil activation, which ultimately precedes myocardial injury. Although future prospective studies are warranted to confirm these results, the current findings support the rationale to further evaluate MPO for risk stratification in patients with ACS and encourage the development of pharmacological strategies to modulate the catalytic activity of this enzyme.

### *Interleukin-10 as a Marker of Inflammatory Balance*

Inflammatory balance may also play an important role in patients with ACS (57,58). Interleukin (IL)-10 is secreted by activated monocytes/macrophages and lymphocytes (59). It has multifaceted anti-inflammatory properties including inhibition of the prototypic proinflammatory transcription factor nuclear factor- $\kappa\text{B}$  leading to suppressed cytokine production (60), inhibition of matrix-degrading metalloproteinases (61), reduction of tissue factor expression (62), inhibition of apoptosis of macrophages and monocytes following infection (63,64), and promotion of the phenotypic switch of lymphocytes into the Th2 phenotype (65). These inflammatory mechanisms have been shown to play a pivotal role for atherosclerotic lesion development and progression, suggesting a potential regulatory role of IL-10. Indeed, numerous recent experimental studies have shown that either systemic or local IL-10 gene transfer not only attenuates atherogenesis (59,66,67) but also affects processes associated with lesion progression (65).

More important, in the CAPTURE trial, elevated serum levels of IL-10 were associated with a significantly improved outcome in patients with ACS (Fig. 12) (58). The predictive value of IL-10 serum levels was independent of elevated troponin levels, which reflect the acute risk secondary to thrombotic complications during an ACS. Thus, a reduced IL-10 serum level not only is a marker of plaque instability favoring the development of ACSs, but, more important, is indicative of a poor prognosis even after the occurrence of an



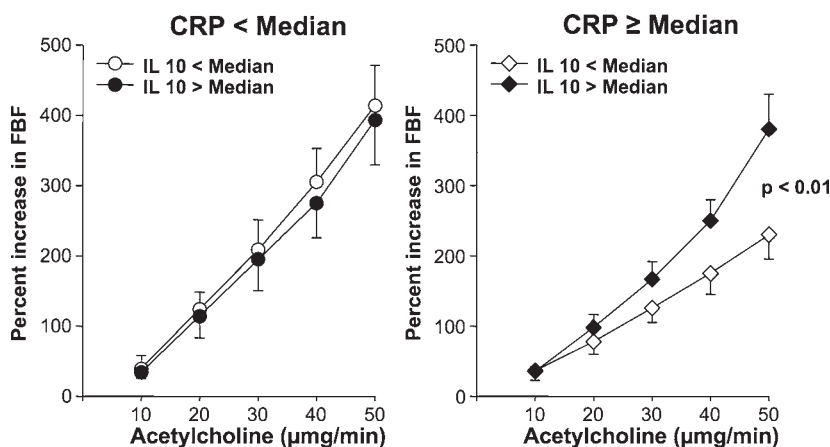
**Fig. 12.** Importance of inflammatory balance in patients with ACS. The cumulative incidence of death or nonfatal MI at 6 mo of follow-up by baseline levels of hsCRP and IL-10, respectively, is shown. Diagnostic threshold levels were 3.5 ng/L for IL-10 and 10 mg/L for CRP ( $n = 547$ ). MHC, major histocompatibility complex; TCR, T-cell receptor; GITR, glucocorticoid-induced tumor necrosis factor receptor.

acute ischemic event caused by plaque instability. In addition, the beneficial effect of elevated serum levels of IL-10 was restricted to patients with elevated CRP levels indicative of an enhanced systemic inflammatory response. These data further support the concept that the balance between pro- and anti-inflammatory cytokines is a major determinant of patients' outcome in ACSs.

Consistently, increased IL-10 serum levels in patients with coronary heart disease are also associated with improved systemic endothelial vasoreactivity in patients with elevated CRP serum levels, whereas in patients with high IL-10 serum levels, systemic endothelial vasoreactivity was independent of CRP concentration (Fig. 13) (68). This demonstrates that the balance between pro- and anti-inflammatory mediators is also a major determinant of endothelial function in patients with CAD.

## CONCLUSION

The electrocardiogram (ECG) remains the most useful and cost-effective first-line tool in the evaluation of patients with chest pain. The initial ECG is the "gold standard" for the diagnosis of an AMI. After exclusion of the presence of ST-elevations, repeat quantitative or qualitative troponin measurements provide valuable diagnostic tools for improving efficacy and safety in decision making for patients suspected of having an ACS. Troponins as biomarkers of myocardial necrosis are superior to and independent of electrocardiographic findings. Increasing evidence suggests that the combined use of biomarkers reflecting distinct pathophysiological features such as myocardial necrosis, vascular inflammation, oxidative stress, and neurohumoral activation may significantly add to clinicians' ability to correctly identify patients who are at high risk of short- and long-



**Fig. 13.** Acetylcholine-induced dose–response curves for forearm blood flow calculated as percent increase in FBF from baseline in patients with CRP levels below median (diamonds) and patients with CRP levels equal to or above median (circles). Solid symbols represent patients with IL-10 serum levels below the median and shaded symbols patients with IL-10 serum levels equal to or above the median. FBF, forearm blood flow.

term cardiovascular events and subsequently tailor medical treatment to improve their adverse outcome.

## REFERENCES

1. Hasdai D, Behar S, Wallentin L, et al. A prospective survey of the characteristics, treatments and outcomes of patients with acute coronary syndromes in Europe and the Mediterranean basin; the Euro Heart Survey of Acute Coronary Syndromes (Euro Heart Survey ACS). *Eur Heart J* 2002;23:1190–1201.
2. Fox KA, Goodman SG, Klein W, et al. Management of acute coronary syndromes. Variations in practice and outcome; findings from the Global Registry of Acute Coronary Events (GRACE). *Eur Heart J* 2002; 23:1177–1189.
3. Ross R. Atherosclerosis—an inflammatory disease. *N Engl J Med* 1999;340:115–126.
4. Libby P. Molecular bases of the acute coronary syndromes. *Circulation* 1995;91:2844–2850.
5. Davies MJ, Thomas AC, Knapman PA, Hangartner JR. Intramyocardial platelet aggregation in patients with unstable angina suffering sudden ischemic cardiac death. *Circulation* 1986;73:418–427.
6. Antman EM, Tanasijevic MJ, Thompson B, et al. Cardiac-specific troponin I levels to predict the risk of mortality in patients with acute coronary syndromes. *N Engl J Med* 1996;335:1342–1349.
7. Hamm CW, Ravkilde J, Gerhardt W, et al. The prognostic value of serum troponin T in unstable angina. *N Engl J Med* 1992;327:146–150.
8. Hamm CW, Goldmann BU, Heeschen C, Kreyman G, Berger J, Meinertz T. Emergency room triage of patients with acute chest pain by means of rapid testing for cardiac troponin T or troponin I. *N Engl J Med* 1997;337:1648–1653.
9. Ohman EM, Armstrong PW, Christenson RH, et al. Cardiac troponin T levels for risk stratification in acute myocardial ischemia. GUSTO IIA Investigators. *N Engl J Med* 1996;335:1333–1341.
10. Hamm CW, Heeschen C, Goldmann B, et al. Benefit of abciximab in patients with refractory unstable angina in relation to serum troponin T levels. c7E3 Fab Antiplatelet Therapy in Unstable Refractory Angina (CAPTURE) Study Investigators. *N Engl J Med* 1999;340:1623–1629.
11. Ridker PM. Clinical application of C-reactive protein for cardiovascular disease detection and prevention. *Circulation* 2003;107:363–369.
12. Koenig W, Lowel H, Baumert J, Meisinger C. C-reactive protein modulates risk prediction based on the Framingham Score: implications for future risk assessment: results from a large cohort study in southern Germany. *Circulation* 2004;109:1349–1353.
13. Danesh J, Wheeler JG, Hirschfield GM, et al. C-reactive protein and other circulating markers of inflammation in the prediction of coronary heart disease. *N Engl J Med* 2004;350:1387–1397.

14. Danesh J, Whincup P, Walker M, et al. Low grade inflammation and coronary heart disease: prospective study and updated meta-analyses. *BMJ* 2000;321:199–204.
15. Koenig W. Update on C-reactive protein as a risk marker in cardiovascular disease. *Kidney Int Suppl* 2003;63(Suppl 84):S58–S61.
16. Ridker PM, Rifai N, Rose L, Buring JE, Cook NR. Comparison of C-reactive protein and low-density lipoprotein cholesterol levels in the prediction of first cardiovascular events. *N Engl J Med* 2002;347:1557–1565.
17. Liuzzo G, Biasucci LM, Gallimore JR, et al. The prognostic value of C-reactive protein and serum amyloid A protein in severe unstable angina. *N Engl J Med* 1994;331:417–424.
18. Morrow DA, Rifai N, Antman EM, et al. C-reactive protein is a potent predictor of mortality independently of and in combination with troponin T in acute coronary syndromes: a TIMI 11A substudy. *Thrombolysis in Myocardial Infarction. J Am Coll Cardiol* 1998;31:1460–1465.
19. Heeschen C, Hamm CW, Bruemmer J, Simoons ML. Predictive value of C-reactive protein and troponin T in patients with unstable angina: a comparative analysis. CAPTURE Investigators. Chimeric c7E3 AntiPlatelet Therapy in Unstable angina REfractory to standard treatment trial. *J Am Coll Cardiol* 2000;35:1535–1542.
20. Lindahl B, Toss H, Siegbahn A, Venge P, Wallentin L. Markers of myocardial damage and inflammation in relation to long-term mortality in unstable coronary artery disease. FRISC Study Group. *Fragmin During Instability in Coronary Artery Disease. N Engl J Med* 2000;343:1139–1147.
21. James SK, Lindahl B, Siegbahn A, et al. N-terminal pro-brain natriuretic peptide and other risk markers for the separate prediction of mortality and subsequent myocardial infarction in patients with unstable coronary artery disease: a Global Utilization of Strategies to Open occluded arteries (GUSTO)-IV substudy. *Circulation* 2003;108:275–281.
22. Fichtlscherer S, Kaszkin M, Breuer S, Dimmeler S, Zeiher AM. Elevated secretory non-pancreatic type II phospholipase A2 serum activity is associated with impaired endothelial vasodilator function in patients with coronary artery disease. *Clin Sci (Lond)* 2004;106:511–517.
23. Liu PY, Li YH, Tsai WC, et al. Prognostic value and the changes of plasma levels of secretory type II phospholipase A2 in patients with coronary artery disease undergoing percutaneous coronary intervention. *Eur Heart J* 2003;24:1824–1832.
24. Kugiyama K, Ota Y, Sugiyama S, et al. Prognostic value of plasma levels of secretory type II phospholipase A2 in patients with unstable angina pectoris. *Am J Cardiol* 2000;86:718–722.
25. Koenig W, Khuseynova N, Lowel H, Trischler G, Meisinger C. Lipoprotein-associated phospholipase A2 adds to risk prediction of incident coronary events by C-reactive protein in apparently healthy middle-aged men from the general population: results from the 14-year follow-up of a large cohort from southern Germany. *Circulation* 2004;110:1903–1908.
26. Prescott MF, Sawyer WK, Von Linden-Reed J, et al. Effect of matrix metalloproteinase inhibition on progression of atherosclerosis and aneurysm in LDL receptor-deficient mice overexpressing MMP-3, MMP-12, and MMP-13 and on restenosis in rats after balloon injury. *Ann NY Acad Sci* 1999;878:179–190.
27. Nikkari ST, Geary RL, Hatsukami T, et al. Expression of collagen, interstitial collagenase, and tissue inhibitor of metalloproteinases-1 in restenosis after carotid endarterectomy. *Am J Pathol* 1996;148:777–783.
28. Bayes-Genis A, Conover CA, Overgaard MT, et al. Pregnancy-associated plasma protein A as a marker of acute coronary syndromes. *N Engl J Med* 2001;345:1022–1029.
29. Lawrence JB, Oxvig C, Overgaard MT, et al. The insulin-like growth factor (IGF)-dependent IGF binding protein-4 protease secreted by human fibroblasts is pregnancy-associated plasma protein-A. *Proc Natl Acad Sci USA* 1999;96:3149–3153.
30. Lund J, Qin QP, Ilva T, et al. Circulating pregnancy-associated plasma protein A predicts outcome in patients with acute coronary syndrome but no troponin I elevation. *Circulation* 2003;108:1924–1926.
31. Cosin-Sales J, Christiansen M, Kaminski P, et al. Pregnancy-associated plasma protein A and its endogenous inhibitor, the proform of eosinophil major basic protein (proMBP), are related to complex stenosis morphology in patients with stable angina pectoris. *Circulation* 2004;109:1724–1728.
32. Luttun A, Tjwa M, Moons L, et al. Revascularization of ischemic tissues by PIGF treatment, and inhibition of tumor angiogenesis, arthritis and atherosclerosis by anti-Flt1. *Nat Med* 2002;8:831–840.
33. Maglione D, Guerriero V, Viglietto G, Delli-Bovi P, Persico MG. Isolation of a human placenta cDNA coding for a protein related to the vascular permeability factor. *Proc Natl Acad Sci USA* 1991;88:9267–9271.
34. Autiero M, Luttun A, Tjwa M, Carmeliet P. Placental growth factor and its receptor, vascular endothelial growth factor receptor-1: novel targets for stimulation of ischemic tissue revascularization and inhibition of angiogenic and inflammatory disorders. *J Thromb Haemost* 2003;1:1356–1370.

35. Heeschen C, Dimmeler S, Fichtlscherer S, et al. Prognostic value of placental growth factor in patients with acute chest pain. *JAMA* 2004;291:435–441.
36. Heeschen C, Hamm CW, Goldmann B, Deu A, Langenbrink L, White HD. Troponin concentrations for stratification of patients with acute coronary syndromes in relation to therapeutic efficacy of tirofiban. PRISM Study Investigators. Platelet Receptor Inhibition in Ischemic Syndrome Management. *Lancet* 1999;354:1757–1762.
37. Heeschen C, Dimmeler S, Hamm CW, et al. Soluble CD40 ligand in acute coronary syndromes. *N Engl J Med* 2003;348:1104–1111.
38. Lee SH, Wolf PL, Escudero R, Deutsch R, Jamieson SW, Thistlethwaite PA. Early expression of angiogenesis factors in acute myocardial ischemia and infarction. *N Engl J Med* 2000;342:626–633.
39. Khaliq A, Dunk C, Jiang J, et al. Hypoxia down-regulates placenta growth factor, whereas fetal growth restriction up-regulates placenta growth factor expression: molecular evidence for “placental hyperoxia” in intrauterine growth restriction. *Lab Invest* 1999;79:151–170.
40. Cao Y, Linden P, Shima D, Browne F, Folkman J. In vivo angiogenic activity and hypoxia induction of heterodimers of placenta growth factor/vascular endothelial growth factor. *J Clin Invest* 1996;98:2507–2511.
41. Heeschen C, Dimmeler S, Hamm CW, Boersma E, Zeiher AM, Simoons ML. Prognostic significance of angiogenic growth factor serum levels in patients with acute coronary syndromes. *Circulation* 2003;107:524–530.
42. Hamm CW, Braunwald E. A classification of unstable angina revisited. *Circulation* 2000;102:118–122.
43. Luttun A, Tjwa M, Carmeliet P. Placental growth factor (PlGF) and its receptor Flt-1 (VEGFR-1): novel therapeutic targets for angiogenic disorders. *Ann NY Acad Sci* 2002;979:80–93.
44. Garlichs CD, Eskafi S, Raaz D, et al. Patients with acute coronary syndromes express enhanced CD40 ligand/CD154 on platelets. *Heart* 2001;86:649–655.
45. Prasad KS, Andre P, Yan Y, Phillips DR. The platelet CD40L/GP IIb-IIIa axis in atherothrombotic disease. *Curr Opin Hematol* 2003;10:356–361.
46. Varo N, de Lemos JA, Libby P, et al. Soluble CD40L: risk prediction after acute coronary syndromes. *Circulation* 2003;108:1049–1052.
47. Gabay C, Kushner I. Acute-phase proteins and other systemic responses to inflammation. *N Engl J Med* 1999;340:448–454.
48. Buffon A, Biasucci LM, Liuzzo G, D’Onofrio G, Crea F, Maseri A. Widespread coronary inflammation in unstable angina. *N Engl J Med* 2002;347:5–12.
49. Biasucci LM, Liuzzo G, Caligiuri G, et al. Episodic activation of the coagulation system in unstable angina does not elicit an acute phase reaction. *Am J Cardiol* 1996;77:85–87.
50. Klebanoff SJ. Myeloperoxidase. *Proc Assoc Am Physicians* 1999;111:383–389.
51. Podrez EA, Abu-Soud HM, Hazen SL. Myeloperoxidase-generated oxidants and atherosclerosis. *Free Radic Biol Med* 2000;28:1717–1725.
52. Fu X, Kassim SY, Parks WC, Heinecke JW. Hypochlorous acid oxygenates the cysteine switch domain of pro-matrilysin (MMP-7): a mechanism for matrix metalloproteinase activation and atherosclerotic plaque rupture by myeloperoxidase. *J Biol Chem* 2001;276:41,279–41,287.
53. Abu-Soud HM, Khassawneh MY, Sohn JT, Murray P, Haxhiu MA, Hazen SL. Peroxidases inhibit nitric oxide (NO) dependent bronchodilation: development of a model describing NO-peroxidase interactions. *Biochemistry* 2001;40:11,866–11,875.
54. Eiserich JP, Baldus S, Brennan ML, et al. Myeloperoxidase, a leukocyte-derived vascular NO oxidase. *Science* 2002;296:2391–2394.
55. Baldus S, Heeschen C, Meinertz T, et al. Myeloperoxidase serum levels predict risk in patients with acute coronary syndromes. *Circulation* 2003;108:1440–1445.
56. Brennan ML, Penn MS, Van Lente F, et al. Prognostic value of myeloperoxidase in patients with chest pain. *N Engl J Med* 2003;349:1595–1604.
57. Anguera I, Miranda-Guardiola F, Bosch X, et al. Elevation of serum levels of the anti-inflammatory cytokine interleukin-10 and decreased risk of coronary events in patients with unstable angina. *Am Heart J* 2002;144:811–817.
58. Heeschen C, Dimmeler S, Hamm CW, et al. Serum level of the antiinflammatory cytokine interleukin-10 is an important prognostic determinant in patients with acute coronary syndromes. *Circulation* 2003;107:2109–2114.
59. Mallat Z, Besnard S, Duriez M, et al. Protective role of interleukin-10 in atherosclerosis. *Circ Res* 1999;85:e17–e24.

60. Wang P, Wu P, Siegel MI, Egan RW, Billah MM. Interleukin (IL)-10 inhibits nuclear factor kappa B (NF kappa B) activation in human monocytes: IL-10 and IL-4 suppress cytokine synthesis by different mechanisms. *J Biol Chem* 1995;270:9558–9563.
61. Lacraz S, Nicod LP, Chicheportiche R, Welgus HG, Dayer JM. IL-10 inhibits metalloproteinase and stimulates TIMP-1 production in human mononuclear phagocytes. *J Clin Invest* 1995;96:2304–2310.
62. Lindmark E, Tenno T, Chen J, Siegbahn A. IL-10 inhibits LPS-induced human monocyte tissue factor expression in whole blood. *Br J Haematol* 1998;102:597–604.
63. Arai T, Hiromatsu K, Nishimura H, et al. Endogenous interleukin 10 prevents apoptosis in macrophages during Salmonella infection. *Biochem Biophys Res Commun* 1995;213:600–607.
64. Geng Y, Shane RB, Berencsi K, et al. Chlamydia pneumoniae inhibits apoptosis in human peripheral blood mononuclear cells through induction of IL-10. *J Immunol* 2000;164:5522–5529.
65. Pinderski LJ, Fischbein MP, Subbanagounder G, et al. Overexpression of interleukin-10 by activated T lymphocytes inhibits atherosclerosis in LDL receptor-deficient mice by altering lymphocyte and macrophage phenotypes. *Circ Res* 2002;90:1064–1071.
66. Pinderski Oslund LJ, Hedrick CC, Olvera T, et al. Interleukin-10 blocks atherosclerotic events in vitro and in vivo. *Arterioscler Thromb Vasc Biol* 1999;19:2847–2853.
67. Von Der Thusen JH, Kuiper J, Fekkes ML, De Vos P, Van Berkel TJ, Biessen EA. Attenuation of atherogenesis by systemic and local adenovirus-mediated gene transfer of interleukin-10 in LDLr<sup>-/-</sup> mice. *FASEB J* 2001;15:2730–2732.
68. Fichtlscherer S, Breuer S, Heeschen C, Dimmeler S, Zeiher AM. Interleukin-10 serum levels and systemic endothelial vasoreactivity in patients with coronary artery disease. *J Am Coll Cardiol* 2004;44:44–49.





# 19

---

## Biomarkers of Inflammation

### *Implications in Patients With Heart Failure*

---

*Biykem Bozkurt, MD, FACC*

#### CONTENTS

INTRODUCTION

INFLAMMATORY BIOMARKERS THAT HAVE BEEN IMPLICATED  
IN PATHOGENESIS OF HEART FAILURE

OTHER INFLAMMATORY BIOMARKERS IMPLICATED IN HEART FAILURE

USE OF INFLAMMATORY BIOMARKERS IN MANAGEMENT OF PATIENTS  
WITH HEART FAILURE

CONCLUSION

REFERENCES

---

#### SUMMARY

Heart failure is characterized by an ongoing inflammatory response. The inflammation hypothesis, as it currently stands, suggests that heart failure progresses because certain inflammatory mediators such as inflammatory cytokines are activated following the initial myocardial injury and continue to exert deleterious effects on the heart and circulation contributing further to progression of heart failure and left ventricular dysfunction. Inflammatory biomarkers in heart failure comprise a portfolio of markers that include biologically active molecules, such as proinflammatory cytokines and chemokines that are involved in the pathogenesis and progression of heart failure, and others that reflect severity of inflammation such as C-reactive protein or erythrocyte sedimentation rate. Most of these biomarkers correlate with severity of disease, prognosis, and clinical outcomes in heart failure.

**Key Words:** Inflammation; heart failure; biomarkers; cytokines; chemokines; tumor necrosis factor; interleukin-6; erythrocyte sedimentation rate; C-reactive protein.

#### INTRODUCTION

Myocardial inflammation not only is a feature of acute injury such as myocardial infarction (MI), myocarditis, or allograft rejection in the myocardium, but also is recognized as a feature of chronic heart failure. It is now well recognized that advanced heart failure is characterized by an ongoing inflammatory response that correlates with the severity

From: *Contemporary Cardiology:  
Cardiovascular Biomarkers: Pathophysiology and Disease Management*  
Edited by: David A. Morrow © Humana Press Inc., Totowa, NJ

Table 1  
Peripheral Levels of Cytokines and Cytokine Receptors in Heart Failure<sup>a</sup>

Reference	Cytokine					Cytokine receptor			
	TNF- $\alpha$	IL-1	IL-2	IL-6	IFN- $\gamma$	sTNFR1	sTNFR2	IL-1RA	IL-6R
1	+	nd	nd	nd	nd	nd	nd	nd	nd
17	+	nd	nd	nd	nd	nd	nd	nd	nd
19	+	nd	nd	nd	nd	nd	nd	nd	nd
21	+	-	nd	+	-	nd	nd	nd	nd
20	+	-	+	nd	nd	nd	nd	nd	nd
18	+	-	-	-	-	nd	nd	nd	nd
22	+	nd	nd	nd	nd	+	+	nd	nd
9	+	nd	nd	nd	nd	+	+	nd	nd
8	+	nd	nd	+	nd	nd	nd	nd	nd
23	+	nd	nd	nd	nd	+	nd	+	nd
24	-	-	nd	+	nd	nd	nd	nd	nd
25	+	+	-	+	nd	nd	+	+	+
26	+	nd	nd	nd	nd	nd	nd	nd	nd
27	+	nd	nd	+	nd	nd	nd	nd	nd
28	+	nd	nd	+	nd	nd	nd	nd	nd
29	+	nd	nd	+	nd	nd	nd	nd	nd
30	+	nd	nd	nd	nd	+	+	nd	nd
71	+	nd	nd	+	nd	nd	nd	nd	nd
61	+	nd	nd	+	nd	+	+	nd	-
72	+	nd	nd	+	nd	nd	nd	nd	-
74	+	nd	nd	+	nd	+	+	nd	nd
31	+	nd	nd	+	nd	+	+	nd	nd

<sup>a</sup>nd, not done; +, levels elevated; -, levels not elevated.

of heart failure disease and prognosis. The current inflammation hypothesis suggests that heart failure progresses because inflammatory mediators that are activated following the initial myocardial injury or stretch continue to exert deleterious effects on the heart and circulation contributing to further progression of heart failure and left ventricular (LV) dysfunction.

The link between heart failure and inflammation was formally recognized and reported in 1990 by Levine et al. (1), who described that the concentration of an inflammatory cytokine, tumor necrosis factor (TNF)- $\alpha$ , was elevated in the setting of heart failure. Interestingly, the pathophysiological importance of inflammation in the heart was recognized as early as 1669, by an English physician, Richard Lower, who, in his major work *Tractatus de Corde*, wrote, “[B]ut when the parenchyma of the heart has been harmed by various diseases its motion is necessarily much altered; for if the parenchyma of the heart ... labors under inflammation, abscess or wound, it cannot vibrate or contract without great trouble or difficulty, it soon gives up its motion, whence the movement of the blood also to the same degree becomes weak and languid” (2). Since the first report of high serum levels of TNF in patients with heart failure (1), a number of studies have shown that other proinflammatory cytokines and chemokines are involved in cardiac depression and the progression of heart failure (3–11) (Table 1). Subsequently, there has been growing interest in the role of inflammatory mediators in regulating cardiac structure and function, particularly regarding their potential role in progression of disease in heart failure. The growing appreciation of the pathophysiological consequences of sustained expression of proinflam-

matory mediators in preclinical and clinical heart failure models culminated in a series of multicenter clinical trials that used “targeted” approaches to neutralize TNF in patients with moderate to advanced heart failure. However, these targeted approaches have resulted in worsening heart failure (12,13).

In this chapter, I review the implications of inflammatory biomarkers in heart failure, with emphasis first on biomarkers that are involved in the pathogenesis of heart failure such as the proinflammatory cytokines and chemokines, and then on other inflammatory biomarkers that reflect severity of inflammation and correlate with severity of disease, prognosis, and clinical outcomes in heart failure such as C-reactive protein (CRP) and erythrocyte sedimentation rate (ESR). Markers of necrosis and of hemodynamic stress in patients with heart failure are discussed in Chapters 8 and 25, respectively.

## INFLAMMATORY BIOMARKERS THAT HAVE BEEN IMPLICATED IN PATHOGENESIS OF HEART FAILURE

### *Proinflammatory Cytokines*

#### OVERVIEW OF PROINFLAMMATORY CYTOKINES INVOLVED IN HEART FAILURE

The term *cytokine* is applied to a group of relatively small molecular weight protein molecules (generally 15–30 kDa) that are secreted by cells in response to a variety of different inducing stimuli. Classically, cytokines are thought to be secreted by neighboring “producer cells” to act in an autocrine, a juxtacrine, or a paracrine fashion to influence the biological behavior of neighboring “target cells” (14,15). Although similar in many respects to polypeptide hormones, cytokines can be produced by a variety of different cell types in a number of different tissues, as opposed to being produced by a specific cell type in a specific organ, as is the case for polypeptide hormones. The group of cytokines that is responsible for initiating both the primary host response to a bacterial infection and the repair of tissue following tissue injury has been termed *proinflammatory cytokines*. Thus far two major classes of cytokines have been identified in heart failure: vasoconstrictor cytokines, such as endothelin, and vasodepressor proinflammatory cytokines, such as TNF, interleukin (IL)-6, IL-1 family (5). These inflammatory mediators are now known to be expressed by all nucleated cell types residing in the myocardium, including the cardiac myocyte, thus suggesting that these molecules may do more than simply orchestrate inflammatory responses in the heart (16). As discussed later, each of these cytokines is capable not only of influencing the expression of the other proinflammatory cytokines, but also of modulating cardiovascular performance when expressed at sufficiently high levels. Furthermore, peripheral circulating as well as intracardiac concentrations of these cytokines are elevated in patients with heart failure (1,9,17–20). Table 1 provides a summary of the studies that have examined circulating levels of cytokines and cytokine receptors in patients with heart failure. Most of these studies consistently described elevated levels of TNF- $\alpha$  in heart failure (1,8,9,17–31). The experimental and clinical data on the role of TNF- $\alpha$ , IL-6, and IL-1 in heart failure are reviewed in detail in the following sections. Comparatively less is known about IL-2 and interferon (IFN)- $\gamma$  in heart failure.

#### TUMOR NECROSIS FACTOR

For at least a century, proinflammatory cytokines have been known to be associated with sepsis and cardiogenic shock (32). At the beginning of the 20th century, a physician named William Coley, who began his career as a young surgeon at New York Memorial Hospital,

found that a vaccine containing two killed bacteria, *Streptococcus pyogenes* and *Serratia marcescens* (later to become known as “Coley’s toxins”), could induce tumor necrosis in unresectable malignancies but could also produce fatal hypotensive shock and pulmonary edema (33). “Coley’s toxins,” which caused tumor necrosis contained a “myocardial depressant factor,” the molecular nature of which has eluded definitive identification in the intervening years. Subsequently, O’Malley et al. (34) showed that the tumor regression effects were mediated through the induction of a factor in the serum, which they named tumor-necrotizing factor, which was renamed by Lloyd J. Old’s group as TNF (35). The sequence homology between TNF and lymphotoxin, a protein produced by lymphocytes that kills tumor cells, led to the renaming of TNF to TNF- $\alpha$  and lymphotoxin to TNF- $\beta$ , respectively. Soon after, Beutler et al. (36) independently discovered mouse TNF- $\alpha$  as a factor that mediated wasting (cachexia) in mice. These two cytokines, TNF- $\alpha$  and TNF- $\beta$ , laid the foundation for the isolation and identification of the larger family of cytokines, now known as the TNF superfamily referred to as TNF (37). Similarly, more than 25 yr ago, Lefer and Rovetto (38) reported that the sera of septic patients and experimental animals contained a “myocardial depressant factor.” During the past decade, Parrillo and colleagues (39,40) using intact animals and in vitro isolated heart cell preparations to investigate systematically the factors that contributed to myocardial depression in systemic sepsis, concluded that it was in fact TNF and IL-1 $\beta$  that were responsible for most, if not all, of the reversible cardiac depression often seen with sepsis syndrome.

TNF, originally defined by its antitumor activity in vitro and in vivo in 1984 (35,41), is now recognized as a cytokine with pleiotropic biological capacities. Research during the past two decades has shown the existence of a superfamily of TNF proteins consisting of 19 members (including TNF- $\alpha$ ) that signal through 29 receptors (37). These ligands, although regulating normal functions such as immune responses, hematopoiesis, and morphogenesis, have also been implicated in tumorigenesis, heart failure, transplant rejection, septic shock, viral replication, bone resorption, rheumatoid arthritis, and diabetes, hence indicating their role as “double-edged swords” (37). Blockers of TNF have been approved for human use in treating TNF-linked autoimmune diseases such as rheumatoid arthritis (37). Besides its cytostatic and cytotoxic effects on certain tumor cells, TNF influences growth, differentiation, and/or function of virtually every cell type investigated, including the cardiac myocyte (42,43). Moreover, TNF is thought to be part of an integral network that orchestrates inflammatory, immunological, and neurohormonal signaling. Thus, TNF stimulates macrophages and other cell types to produce other proinflammatory cytokines including IL-1, IL-6, IL-8, and TNF- $\alpha$  itself (14). The major cellular source of TNF is the activated macrophage, although a variety of different cell types, including lymphocytes, neutrophils, fibroblasts, endothelial cells, smooth muscle cells, and cardiac myocytes (5,9), are capable of producing this cytokine. In vivo, it appears that the expression of TNF is tissue specific. That is, under basal conditions, TNF is produced primarily by the thymus; however, after stimulation with lipopolysaccharide, TNF is also produced by the kidney, pancreas, uterus, and fallopian tubes, as well as the heart (44). In low concentrations ( $[10^{-10}]$  mol/L), TNF- $\alpha$  is thought to act primarily as a paracrine or an autocrine regulator of leukocytes and endothelial cells and, therefore, regulates the inflammatory responses to microbes and facilitates tissue repair. In higher concentrations ( $\oplus[10^{-8}]$  mol/L), TNF- $\alpha$  production far exceeds the number of TNF receptors (TNFRs) in a given tissue, with the result that TNF- $\alpha$  “spills over” into the bloodstream, where it can act as an endocrine hormone and lead to metabolic wasting (cachexia), potentially lethal

Table 2  
Deleterious Effects of Proinflammatory Cytokines in Heart Failure<sup>a</sup>

- Left ventricular dysfunction in humans (130)
- Pulmonary edema in humans (131)
- Cardiomyopathy in humans (132)
- Left ventricular remodeling experimentally (3,47,48)
- Abnormalities in myocardial metabolism experimentally (133)
- Anorexia and cachexia experimentally (134)
- $\beta$ -Receptor uncoupling from adenylate cyclase experimentally (135)
- Abnormalities of mitochondrial energetics (136)
- Activation of fetal gene program experimentally (137)
- Cardiac myocyte apoptosis experimentally (56,138)

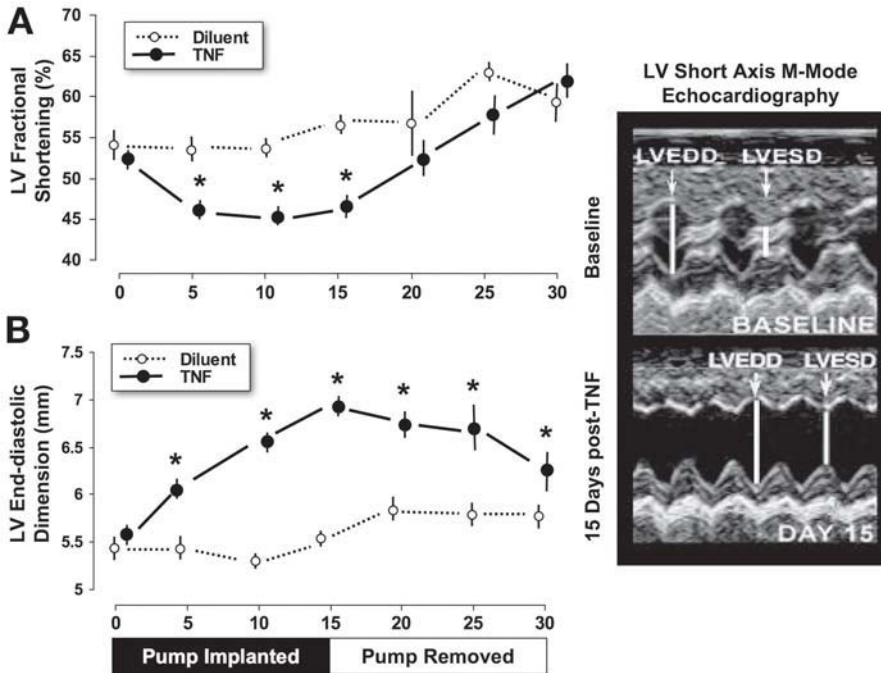
<sup>a</sup>Modified from ref. 7 with permission.

microvascular coagulation, and hypotension. Neither TNF mRNA nor TNF protein appears to be constitutively expressed in the nonfailing heart; by contrast, TNF mRNA and protein appear to be uniformly expressed in failing human hearts (9). Thus, similar to neurohormones, TNF and its family members are “double-edged swords.” Whereas physiologically they are important cytokines and required for normal responses, their inappropriate expression is harmful (37).

Cytokines are thought to exert their effects by binding to specific receptors on the surface of the cell including the adult cardiac myocyte. In the case of TNF, this protein is known to bind to two types of TNFRs: TNFR1 (p 55) and TNFR2 (p 75) receptor. The adult human cardiac myocyte expresses both types of TNF receptors, and the type 1 receptor is responsible for mediating the negative inotropic effects of TNF (9,16). Studies have also shown that both TNFRs are proteolytically cleaved from the cell membrane, and that they exist in the circulation as circulating soluble receptors, referred to as sTNFR1 and sTNFR2, respectively. Interestingly, both these receptors retain their ability to bind their ligand, as well as to inhibit the cytotoxic activities of TNF. It has been suggested that they may serve as “biological buffers” that are capable of rapidly neutralizing the highly cytotoxic activities of TNF (45).

**Effects of TNF on heart.** Many aspects of heart failure can be explained by the known biological effects of stress-activated proinflammatory cytokines. When expressed at sufficiently high concentration, TNF can mimic some aspects of heart failure phenotype including but not limited to progressive LV dysfunction, pulmonary edema, LV remodeling, fetal gene expression, and cardiomyopathy (Table 2). The current literature suggests that TNF- $\alpha$  produces both an immediate and a delayed negative inotropic effect on myocardial contractility. Thus, the elaboration of cytokines may represent, much like neurohormones, a biological mechanism that is responsible for producing symptoms in patients with heart failure. As discussed subsequently, there is now a substantial body of evidence suggesting that the sustained expression of cytokines produces frank maladaptive effects in the heart, including deleterious effects on myocardial function and on LV remodeling.

*Effect of TNF on LV Function.* The effect of the proinflammatory cytokines on LV function was first reported in a series of important experimental studies showing that direct injections of TNF would produce hypotension, metabolic acidosis, hemoconcentration, and death within minutes, thus mimicking the hemodynamic response seen during endotoxin-induced septic shock (46). Subsequent studies in dogs have shown that a single

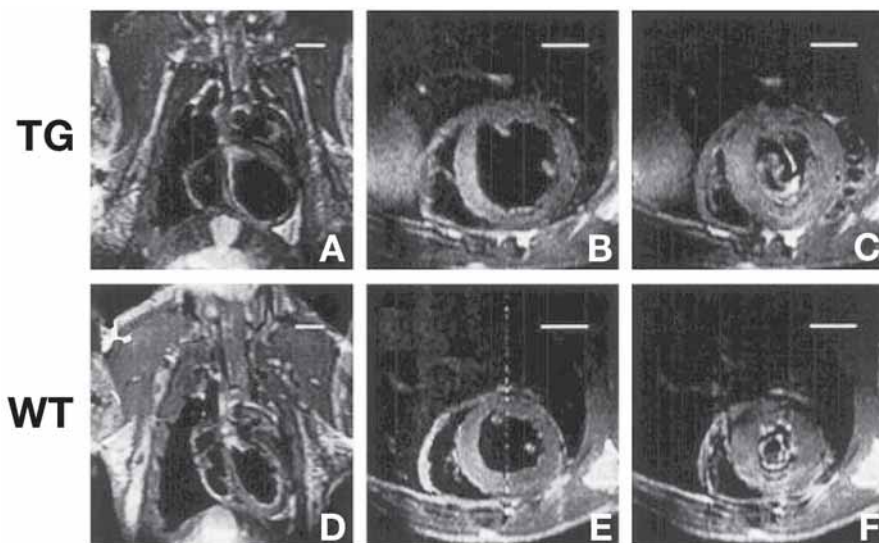


**Fig. 1.** (A) Effect of continuous infusion of TNF- $\alpha$  on LV function in vivo. LV function was studied for 15 d in rats that underwent implantation of ip osmotic infusion containing either diluent ( $n = 20$ ) or TNF- $\alpha$  ( $n = 38$ ). After 15 d, osmotic infusion pumps were removed, and the animals were allowed to recover for an additional 15 d. LV fractional shortening was reduced with TNF- $\alpha$  infusion and improved after infusion pumps (3). (B) Effect of continuous TNF- $\alpha$  infusion in rats on LV geometry in vivo. LV dimensions were studied for 15 d following implantation of an ip osmotic infusion containing either diluent ( $n = 20$ ) or TNF- $\alpha$  ( $2.5 \mu\text{g}/[\text{kg} \cdot \text{min}]$ ;  $n = 38$ ). LV dimensions increased with TNF- $\alpha$  infusion, indicative of LV remodeling induced by TNF- $\alpha$  (3). (C) M-mode echocardiographic images of rat heart at baseline and at 15 d of TNF- $\alpha$  infusion showing reduction in LV fractional shortening and increase in LV dimensions (3). \*Statistical significance with  $p < 0.05$ . LVEDD, left-ventricular end diastolic diameter; LVESD, left-ventricular end systolic diameter. (Reproduced from ref. 3 with permission of the American Heart Association ©1998.)

infusion of TNF results in abnormalities of systolic function within the first 24 h of infusion (47). Similarly, experimental studies in rats have shown that circulating concentrations of TNF that are observed in patients with heart failure are sufficient to produce persistent negative inotropic effects that are detectable at the level of the cardiac myocyte; moreover, the negative inotropic effects of TNF are completely reversible when the TNF infusion is stopped (3) (Fig. 1A,C). In subsequent studies in transgenic mice with targeted overexpression of TNF in the cardiac compartment, forced overexpression of TNF resulted in depressed LV ejection performance; notably, depressed LV ejection performance was dependent on TNF “gene dosage” (48,49).

Similar to TNF- $\alpha$ , both IL-1 and IL-6 produce negative inotropic effects in various experimental models (50,51). In addition to TNF- $\alpha$  and IL-6, other cytokines directly implicated in mediating myocardial depression in systemic sepsis and other forms of cardiac dysfunction include IL-1 $\beta$ , IL-2, and IFN- $\gamma$  (52).

**Effect of TNF on LV remodeling.** In experimental studies, overexpression of TNF can result in LV remodeling (3,48). Specifically, in a rat model, we demonstrated that TNF- $\alpha$  infusion induced a time-dependent increase in LV end diastolic dimension (3). In this



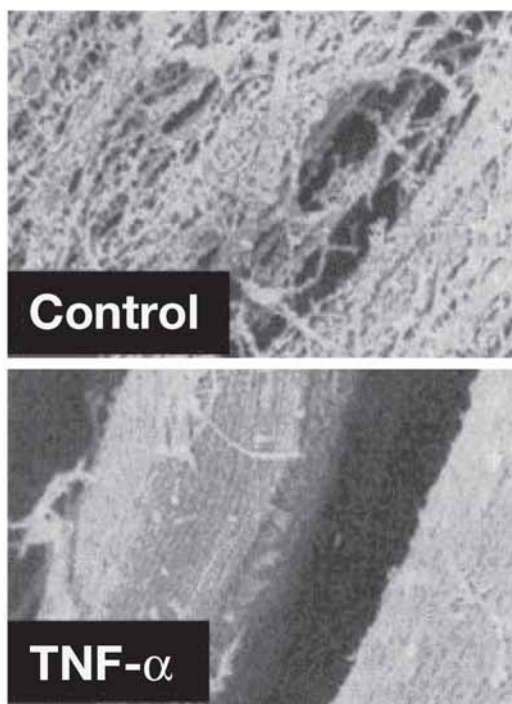
**Fig. 2.** LV remodeling in transgenic mouse model of TNF overexpression. Magnetic resonance images of the heart were obtained from 24-wk-old transgenic (TG) mice with targeted TNF overexpression (A–C) and an age-matched control (WT) mouse (D–F). As shown, there was significant LV dilation in the animal harboring the TNF transgene in the cardiac compartment. Bars = 2.5 mm. (Reproduced from ref. 48 with permission of the American Heart Association ©1997.)

model, following TNF infusion, LV end diastolic dimension increased by >25% when compared to time-matched controls (Fig. 1B). Moreover, in a transgenic mouse model, myocardial TNF- $\alpha$  overexpression results in increased systolic and diastolic LV volumes, a dilated and globoid LV phenotype (Fig. 2) (48).

Important determinants of myocardial wall remodeling include changes in myocyte size and number, alignment of myocytes in the myocardial wall, and changes in myocardial extracellular matrix (ECM). Increased levels of these inflammatory mediators have been demonstrated to cause changes in each of these determinants of remodeling and can result in myocyte hypertrophy (53), alterations in fetal gene expression (48), and progressive myocyte loss through apoptosis (54). In addition to these effects, there are several lines of evidence suggesting that TNF may promote left ventricular remodeling through alterations in the ECM. Increased TNF in animal models has been demonstrated to cause significant changes in the ECM (3,55). For example, chronic TNF- $\alpha$  infusion in rats reduces fibrillar collagen by 50% when compared with controls (3). Scanning electron micrographs of myocardial sections from TNF- $\alpha$ -infused animals reveal disruptions in the myocardial extracellular fibrillar collagen network (Fig. 3). Transgenic mice overexpressing myocardial TNF- $\alpha$  have increased soluble myocardial collagen, suggestive of reduced collagen crosslinking (55). Similar findings have also been reported by others (56,57) who observed LV dysfunction and LV dilation in transgenic mice with targeted overexpression of TNF in the heart.

Thus, in animal models of increased TNF- $\alpha$  expression, defects in extracellular fibrillar collagen structure and composition are known to occur. With respect to the mechanisms that are involved in TNF-induced LV dilation, it has been suggested that TNF-induced activation of matrix metalloproteinases is responsible for this effect (55,57). The current hypothesis regarding the role of TNF in LV remodeling proposes that without altering



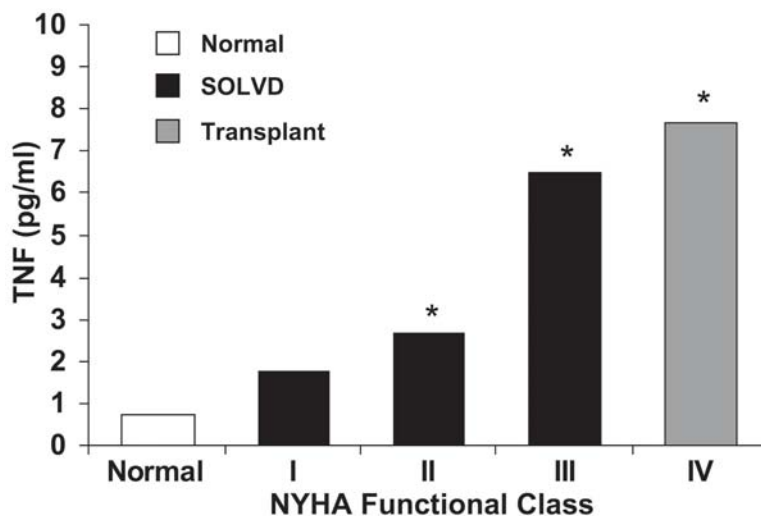


**Fig. 3.** Rats were infused with diluent or TNF- $\alpha$  for 15 d. Representative scanning electron micrographs of LV myocardial sections were taken. In myocardial samples from diluent-treated animals (control), a fine weave of collagen around the myocytes was observed. In myocardial samples from TNF- $\alpha$ -infused animals (TNF- $\alpha$ ), the collagen weave appeared to be significantly disrupted. (Reproduced from ref. 3 with permission of the American Heart Association ©1998.)

preload or afterload, TNF induces LV dilation, perhaps as a result of ECM degradation, allowing rearrangement (“slippage”) of bundles or groups of cardiac myocytes. These alterations in LV geometry are further accompanied by systolic and diastolic dysfunction (3,58). Thus, excessive activation of TNF, and possibly of other proinflammatory cytokines, may contribute to the LV remodeling observed in heart failure via mechanisms that involve both myocyte and nonmyocyte elements of the myocardium.

### INTERLEUKIN-6

Originally identified as T-cell-derived cytokine, IL-6 has been recognized as a multifunctional cytokine produced by several cell types of nonimmunological origin. IL-6 can produce myocyte hypertrophy, myocardial dysfunction, and muscle wasting (59). In advanced heart failure, cardiac expression of IL-6 and IL-6 receptor mRNA is increased (60). IL-6 is thought to be released in direct response to TNF- $\alpha$ , and a linear correlation between the two cytokine levels has been described (59,61). IL-6 has two different types of receptors: a private ligand-binding receptor (called membrane  $\alpha$  receptor [R]) and a membrane  $\beta$  receptor (called transmembrane glycoprotein [gp] 130) (62,63). Interestingly, it is the small transmembrane glycoprotein, gp130, but not IL-6 soluble receptor (IL-6R) itself, that renders cells susceptible to IL-6 (63). Indeed, IL-6 can act on cells lacking the expression of IL-6R after complex formation with soluble IL-6R. Both gp130 and IL-6R are always required for signaling. The soluble form of gp130 inactivates the solu-



**Fig. 4.** TNF- $\alpha$  levels in patients with class I–IV heart failure. Compared with age-matched control subjects (open bar), there was a progressive increase in serum TNF- $\alpha$  levels in direct relation to decreasing functional heart failure classification. The solid bars denote values for patients enrolled in Studies of Left Ventricular Dysfunction (SOLVD) (8); the shaded bar denotes values for NYHA class IV patients who were undergoing cardiac transplantation (9). \*Significantly different from normal. (Reproduced from ref. 59 with permission of Churchill Livingstone ©1996.)

ble IL-6/IL-6R complex. However, both the concentration of gp130 and the overall level of bioactivity of IL-6 are increased in heart failure (62).

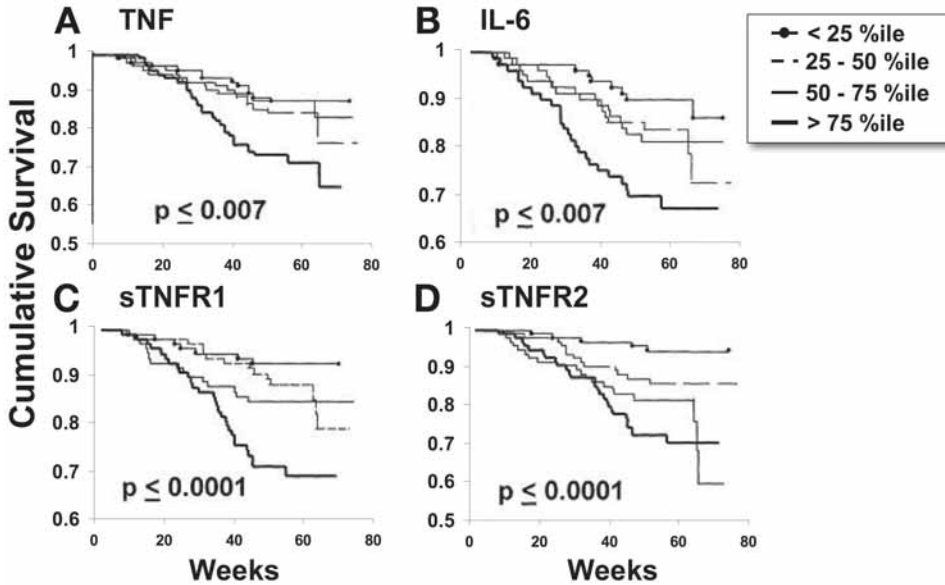
### INTERLEUKIN-1

Another important cytokine in the setting of heart failure is IL-1. This cytokine and TNF- $\alpha$  are generally thought of as the prototypical proinflammatory cytokines. IL-1 has been demonstrated in the myocardium of patients with idiopathic dilated cardiomyopathy (64). Experimentally, it is known to depress myocardial contractility in a dose-dependent fashion (65). The alterations in gene expression seen in response to IL-1 resemble, in many ways, the phenotype of the failing heart (66). These effects are synergistic with those of TNF- $\alpha$ . Additional studies have shown that IL-1 is also involved in myocardial apoptosis, hypertrophy, and arrhythmogenesis (66,67).

### PROINFLAMMATORY CYTOKINE LEVELS ARE ELEVATED AND CORRELATE WITH SEVERITY OF DISEASE IN HEART FAILURE

Circulating levels of TNF and IL-6 are elevated in patients with heart failure. Because they were initially identified in patients with cardiac cachexia (17,68), and edematous decompensation (69), these cytokines were thought to be expressed only in patients with end-stage heart failure. However, as reported in a number of studies (1,8,18–20,24,31,61,70), proinflammatory molecules are activated starting at earlier phases of heart failure (i.e., New York Heart Association [NYHA] class II [8] or asymptomatic left ventricular dysfunction [70]) and continue to rise in direct relation to worsening NYHA functional classification (8,31,59,71) (Fig. 4) regardless of the etiology of the heart failure (8,24,25,61).

In addition to the inflammatory cytokines, circulating levels of cytokine receptors are elevated in heart failure. These include the soluble TNFR (22) and soluble transmembrane



**Fig. 5.** Kaplan-Meier survival analysis. The circulating levels of (A) TNF, (B) IL-6, (C) sTNFR1, and (D) sTNFR2 were examined in relation to patient survival during follow-up (mean duration: 55 wk; maximum duration: 78 wk). For this analysis, the circulating levels of cytokines and cytokine receptors were arbitrarily divided into quartiles. (Reproduced from ref. 31 with permission of the American Heart Association ©2001.)

gp130 (one of the receptors for the IL-6 family), which are increased in patients with heart failure in close relation to functional class (61). Of note, even though IL-6 and gp130 levels are elevated, IL-6R levels are not increased in patients with heart failure (61,72).

Furthermore, increased myocardial TNF- $\alpha$ -converting enzyme expression, which results in the production of a functional enzyme that has precursor TNF- $\alpha$  in the mature form (73), is associated with the degree of left ventricular systolic dysfunction in patients with dilated cardiomyopathy (73).

### PROINFLAMMATORY CYTOKINES PREDICT POOR PROGNOSIS IN HEART FAILURE

As well as correlating with severity of disease (i.e., with worsening functional class), elevated blood levels of proinflammatory cytokines are associated with increased mortality in patients with heart failure. Increased circulating levels of TNF- $\alpha$  (31,74), IL-6 (28,71, 75–77), and sTNFR1 and sTNFR2 (31,74) have been reported to predict poorer survival. As shown in Fig. 5A, among patients participating in the multicenter Vesnarinone Trial (VEST), survival gradually declined as a function of increasing TNF levels, with the worst survival in patients with TNF levels >75th percentile (31). Similarly, circulating levels of IL-6 (Fig. 5B) and sTNFR1 and sTNFR2 were associated with outcome (Fig. 5C,D) (31). Of interest, in a study of 37 patients with heart failure and 26 age-matched control subjects (22), the circulating level of sTNFR2 appeared to be the most powerful predictor of mortality. In a larger study of 152 patients with heart failure, Rauchhaus et al. (74), however, reported that sTNFR1 was the strongest and most accurate prognosticator; the receiver operating characteristic area under the curve for sTNFR1 was greater than for sTNFR2 at 6, 12, and 18 mo (all  $p < 0.05$ ). When examined in VEST with Cox regression modeling adjusting for age, sex, etiology of heart failure, NYHA class, ejection fraction, and serum

sodium, TNF, IL-6, sTNFR1, and sTNFR2 remained significant independent predictors of mortality, along with NYHA class and ejection fraction (31).

Although these clinical studies cannot address whether the findings represent an epiphenomenon that is associated with, but not causally related to, worsening severity of disease and outcomes, the preponderance of data support that the proinflammatory cytokines TNF- $\alpha$  and IL-6 contribute further to progression of heart failure and worsening outcomes in heart failure.

#### **INFLAMMATORY CYTOKINES AS MARKERS FOR MONITORING RESPONSE TO THERAPY IN HEART FAILURE**

Several studies have examined the changes in levels of inflammatory cytokines during standard therapy for heart failure. Some of these changes can be attributed to direct interaction of the medications used, such as the interaction between the neurohormonal antagonists and the proinflammatory cytokines (78,79). Clinical studies have shown that treatment with angiotensin receptor antagonists can lead to significant reductions in circulating levels of TNF and/or cell adhesion molecules in patients with heart failure (80).  $\beta$ -Adrenergic blockade also prevents the expression of inflammatory mediators in post-infarction animal models (81) and reduces proinflammatory cytokine levels in patients with heart failure (82–87). Compared to angiotensin receptor and  $\beta$ -blockers, the effect of angiotensin-converting enzyme (ACE) inhibitors on inflammatory cytokines is not as clear. In an animal infarct model, the use of ACE inhibitors over 28 d resulted in a reduction in cardiac cytokine expression (79). By contrast, in a clinical study by Gullestad et al. (88), treatment with ACE inhibitors over 34 wk was associated with a rise in the peripheral levels of chemokines, cell adhesion molecules, and proinflammatory cytokines except for IL-6. In another study, treatment with the long-acting dihydropyridine calcium antagonist, amlodipine, over 26 wk lowered plasma IL-6 levels in patients with heart failure (28). Similarly, optimization of background standard therapy of heart failure with diuretics, ACE inhibitors,  $\beta$ -blockers, and digoxin can result in significant reductions in circulating levels of TNF- $\alpha$  and IL-6 (75). Histochemical sections of failing human myocardium have shown that after several weeks of mechanical circulatory support with a ventricular assist device, myocardial expression of TNF- $\alpha$  was markedly reduced in patients with heart failure (89).

These studies suggest that there are important interactions between the renin-angiotensin, adrenergic systems and proinflammatory cytokines, and many of the conventional therapies for heart failure may work, at least in part, through the modulation of proinflammatory cytokines. Nevertheless, it should be noted that despite these temporal parallel changes in the levels of cytokines with optimal heart failure therapy, currently there are no data from large-scale studies of the relationship between changes in inflammatory biomarkers over time and morbidity and mortality in patients with heart failure. Furthermore, the sensitivity, specificity, and negative and positive predictive values of inflammatory biomarkers for predicting adverse outcomes in the setting of heart failure are not well defined, and any clinical value of inflammatory markers over and above established parameters remains to be proven (72).

#### **PROINFLAMMATORY CYTOKINES AS THERAPEUTIC TARGETS IN HEART FAILURE**

Clinical studies have been carried out to selectively antagonize inflammatory cytokines, specifically TNF- $\alpha$ , in patients with heart failure using recombinant human TNFRs that act as “decoys” to bind TNF, thereby preventing TNF from binding to TNFRs on cell-

surface membranes of target cells, or monoclonal antibodies (MAbs) from binding and neutralizing circulating cytokines.

Early preclinical studies of TNF antagonism using the TNFR etanercept (Enbrel) showed that etanercept could reverse the deleterious negative inotropic effects of TNF *in vitro* (90) and *in vivo* (3). Subsequently, a series of phase 1 and phase 2 clinical studies was performed in patients with moderate to advanced heart failure and showed improvements in quality of life, 6-min walking distance, and left ventricular ejection performance after treatment with etanercept for up to 3 mo (45,91). Two multicenter clinical trials using etanercept were then completed in patients with NYHA class II–IV heart failure. The trial in North America, entitled Randomized Etanercept North American Strategy to Study Antagonism of Cytokines (RENAISSANCE) ( $n = 900$ ), and the trial in Europe and Australia, entitled Research into Etanercept Cytokine Antagonism in Ventricular Dysfunction (RECOVER) ( $n = 900$ ), were both quality-of-life trials that used a clinical composite as the primary end point. A third trial that used the pooled data from the RENAISSANCE and RECOVER trials, entitled Randomized Etanercept Worldwide Evaluation (RENEWAL) ( $n = 1500$ ), had a primary end point of all-cause mortality and hospitalization for heart failure. The trials were stopped early after the Data Monitoring Safety Board deemed that it is unlikely that the trials would show benefit on the primary end points if the two trials were allowed to go to completion (12). In a post hoc analysis, patients taking the etanercept treatment over a longer period of time had increased risk of death/heart failure hospitalization compared with patients receiving placebo (5,12).

The second targeted anticytokine approach in clinical heart failure trials was the use of MAbs directed against TNF- $\alpha$ . The Anti-TNF- $\alpha$  Therapy Against CHF was a phase 2 study in 150 patients with moderate to advanced heart failure using infliximab (Remicade), a chimeric MAb consisting of a genetically engineered murine Fab fragment (that binds human TNF) fused to a human FC portion of human IgG1. The study showed a dose-related increase in death and heart failure hospitalizations with infliximab compared with placebo (13). In the aftermath of these clinical studies, it was questioned whether the biological agents that were used in the trials had intrinsic toxicity, and/or whether TNF antagonism had untoward effects in the setting of heart failure. Infliximab may be directly cytotoxic to cells expressing TNF on the membrane by inducing complement fixation in the heart, which may lead to sustained myocarditis as well as cardiac myocyte lysis (5). Etanercept, on the other hand, may have stabilized TNF and resulted in the accumulation of high concentrations of immunoreactive TNF in the peripheral circulation (5). This potential increase in the circulating levels of biologically active TNF in patients with heart failure might actually worsen the heart failure status.

### **PROINFLAMMATORY CYTOKINES AS PREDICTORS OF DEVELOPMENT OF HEART FAILURE IN ASYMPTOMATIC PATIENTS**

Elevated levels of IL-6 (92) and TNF (8) have been reported in patients with LV dysfunction in the absence of the clinical symptoms of heart failure. In a subgroup of 732 elderly Framingham study subjects without prior MI and heart failure, Vasan et al. (70) reported that baseline levels of IL-6 and spontaneous production of TNF by peripheral blood mononuclear cells (PBMCs) were predictive of the development of heart failure in the next 5 yr. After adjusting for established risk factors, including the occurrence of MI during follow-up, the investigators found that the risk of developing heart failure increased ~1.6- to 1.7-fold per tertile increment in PBMC TNF and IL-6 levels, respectively. Sub-

jects with increased levels of IL-6, PBMC TNF, and CRP  $\geq 5$  mg/dL had a 4.1-fold risk of developing heart failure. The study population consisted of predominantly elderly, Caucasian subjects (67% female) with a high prevalence of hypertension (~70%), atrial fibrillation (~7%), and preexisting cardiovascular disease without prior documented MI. It is important to point out that in this study there was no assessment of LV function at baseline. Elevated inflammatory markers in this study may have identified patients with vascular disease at risk of MI (93,94) or patients with preexisting subclinical LV dysfunction (92). As pointed out by Murray et al. (95), without a baseline assessment of ventricular function, the study cannot conclude whether IL-6, TNF, and CRP predict the *de novo* development of cardiomyopathy vs the transition between subclinical LV dysfunction and overt heart failure.

### ***Chemokines***

Chemokines are potent proinflammatory and immune modulators. Chemokines regulate several biological processes such as chemotaxis, activation and migration of leukocytes to areas of inflammation, collagen turnover, angiogenesis, and apoptosis (4). TNF- $\alpha$  and other proinflammatory cytokines, such as IL-1 $\beta$  and IL-6 or IFN- $\gamma$ , are known to induce these chemotactic polypeptides (96,97). Potent chemokines such as macrophage chemoattractant protein-1 and macrophage inflammatory protein-1 $\alpha$  (MIP-1 $\alpha$ ) not only can attract the monocytes and the lymphocytes, but also can modulate other functions of these cells, such as the generation of reactive oxygen species (4). Monocyte chemoattractant protein-1 (MCP-1) has been reported to be upregulated in experimental models of heart failure with pressure (65) or volume overload (98). Furthermore, transgenic overexpression of macrophage chemoattractant protein-1 in the myocardium has been shown to result in myocarditis and subsequent development of heart failure in experimental models (99). Similar to the proinflammatory cytokines, the failing human heart expresses chemokine and chemokine receptors (100). Increased expression of chemokines, such as MCP-1, also occurs in patients with heart failure (4). Aukrust et al. (4) reported that patients with heart failure had significantly elevated levels of all chemokines, with the highest levels in those with NYHA class IV symptoms. In their study, MCP-1 and MIP-1 $\alpha$  levels correlated inversely with LV ejection fraction (LVEF). Further studies on cells isolated from peripheral blood of these patients suggest that platelets; CD3<sup>+</sup> lymphocytes; and, in particular, monocytes may contribute to the elevated C-C chemokine levels in heart failure (4).

### ***Cell Adhesion Molecules in Heart Failure***

Cell adhesion molecules have been implicated in the pathogenesis of a variety of CVDs including heart failure (101–103). Adhesion molecules are cell-surface receptors involved in the binding of leukocytes to each other, to endothelial cells, or to the ECM (102). Three different families of proteins have been implicated in heart failure (104):

1. The immunoglobulin superfamily, which consists of a number of adhesion molecules including intracellular adhesion molecule-1 (ICAM-1), ICAM-2, and ICAM-3; vascular cell adhesion molecule-1 (VCAM-1); and others.
2. Integrins, which mediate leukocyte adherence to the vascular endothelium and other cell-cell interactions.
3. The selectins, which are involved in the adhesion of leukocytes to activated endothelium and result in typical “rolling” of leukocytes on the endothelial surface (mainly mediated by leukocyte [L]-selectin and platelet [P]-selectin).

Relative overexpression of ICAM-1 has been described in myocardial tissue obtained at the time of cardiac transplantation from patients with either myocarditis, chronic ischemic heart disease, or dilated cardiomyopathy (101). Upregulation of cell adhesion molecules has been reported in several studies of patients with heart failure. For example, in a study by Tsutamoto et al. (105), among 102 patients with heart failure, plasma levels of soluble ICAM-1 were elevated with worsening severity of heart failure. In addition, the levels of ICAM-1 negatively correlated with LVEF and independently predicted survival (105). Elevated levels of other soluble VCAMs such as VCAM-1, sP-selectin, and sE-selectin have also been described in patients with heart failure (106,107).

## OTHER INFLAMMATORY BIOMARKERS IMPLICATED IN HEART FAILURE

### *C-Reactive Protein*

CRP is a phylogenetically highly conserved plasma protein that participates in the systemic response to inflammation (108). It is produced exclusively in the liver and its plasma concentration increases during inflammatory states, a characteristic that has long been employed for clinical purposes. CRP is a pattern recognition molecule, binding to specific molecular configurations that are typically exposed during cell death or found on the surfaces of pathogens (108). Its rapid increase in synthesis within hours after tissue injury or infection suggests that it contributes to host defense and that it is part of the innate immune response (108). With recognition of its diagnostic and prognostic role in ischemic heart disease, and acute coronary syndromes, CRP has gained an interest as a laboratory marker for standard testing. CRP has also been described to correlate with severity of disease and prognosis in patients with heart failure.

In 1990, Pye et al. (109) reported the first observation of raised concentrations of CRP in heart failure. In their study, the serum concentration of CRP was higher than normal in 70% of patients with heart failure and the concentration was directly related to the severity of heart failure and the stage of decompensation (109). Subsequently, Kaneko et al. (110) measured the concentration of CRP in 188 patients with idiopathic dilated cardiomyopathy and LVEF <40%. Those patients who died during a follow-up period of 5 yr had significantly higher CRP concentrations than those who survived ( $10.5 \pm 13.7$  vs  $4.9 \pm 10.4$  mg/L;  $p < 0.05$ ). Sixty-two percent of the patients with CRP > 10 mg/L died within 5 yr. Similarly, Milo et al. (111) reported that in 30 patients admitted with acute heart failure, CRP levels were elevated in the nonischemic patients as well as the ischemic patients compared with control subjects.

The association between blood concentration of CRP and prognosis in heart failure has been supported by several studies. In a study of 76 patients hospitalized for heart failure, patients with an elevated CRP >9 mg/L were at higher risk of the need for rehospitalization during the 18-mo follow-up period compared with patients with normal CRP levels (112). Similarly, among elderly patients, the relative risk (RR) of heart failure events was increased by 1.48 per each increase in CRP by one standard deviation (113). Given the association of CRP to atherosclerotic coronary events, it should be noted that in studies by Vasan et al. (70) and Cesari et al. (113), the subjects were free of ischemic heart disease at the time of entry; nevertheless, the outcome measures for both studies included ischemic and nonischemic heart failure events.

Vasan et al. (70) reported a potential role for CRP in predicting the “development of heart failure.” They examined the effect of CRP as an antecedent to heart failure among

elderly subjects enrolled in the Framingham Heart Study. Participants with markedly elevated CRP ( $\oplus 50$  mg/L) had a 2.8-fold higher risk of developing heart failure during a follow-up period of approx 5 yr (70).

The use of ACE inhibition and  $\beta$ -blockade has been associated with lower levels of CRP in patients with heart failure (114). At the present time, despite the association of CRP with the severity of heart failure disease and outcomes, it is not clear whether this acute-phase protein is merely a marker of inflammation with no particular role in the development of heart failure or whether it is involved in the pathogenesis and progression of the disease. It is also not clear whether CRP is viable as a biomarker for monitoring the success of therapy for heart failure.

### *Erythrocyte Sedimentation Rate*

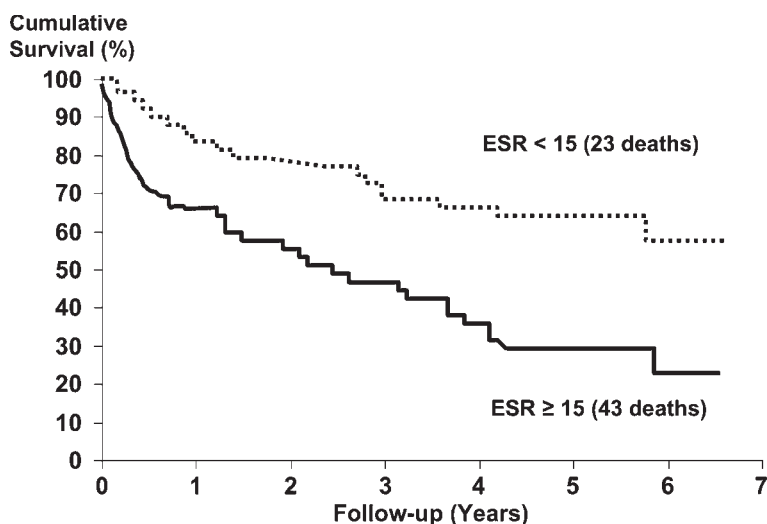
ESR has been of particular interest in heart failure owing to its low cost, easy applicability, and reproducibility. However, clinical studies, which are separated from each other by decades, have yielded conflicting results on the role of ESR in heart failure. Based on the potential misinterpretation of the results in a single report published in 1936 (115), physicians have long believed that ESR is low in patients with heart failure (116–119). To reevaluate this concept in the modern era, Haber et al. (116) measured ESR in 242 patients with heart failure and reported that it was low ( $< 5$  mm/h) in only 10% of the patients but was increased ( $> 25$  mm/h) in 50%. Surprisingly, patients with low or normal sedimentation rates ( $\leq 25$  mm/h) had more severe hemodynamic abnormalities, worse NYHA functional class symptoms, and worse 1-yr survival than patients with elevated ESR rates. Subsequently, in 2001, Sharma et al. (120) studied ESR in relation to plasma levels of inflammatory cytokines and mortality in 159 patients with heart failure. ESR ranged from 1 to 96 mm/h (median: 14 mm/h) with only 16% of patients at  $< 5$  mm/h. In their study, the ESR correlated with TNF, sTNFR1, sTNFR2, and IL-6 levels (120). In contrast with Haber et al.'s (116) study, a high ESR was associated a poor prognosis independently of age, NYHA class, ejection fraction, and peak oxygen consumption. Patients with an ESR  $\oplus 15$  mm/h had a significantly worse survival (hazard ratio of 2.62) (Fig. 6). Sharma et al. (120) suggested that the difference between their and Haber et al.'s (116) findings may be owing to changes in the treatment of heart failure in the period between when the two studies were conducted.

### *Peripheral Leukocyte Subsets in Heart Failure*

Despite the wealth of information available on the role of inflammation in heart failure, relatively little has been published on the prognostic role of white blood cells or the leukocyte subsets in the setting of heart failure. For patients presenting with acute MI, elevated leukocyte count (121,122) or relative neutrophilia ( $> 65\%$ ) on admission has been associated with subsequent development of heart failure (123). Similarly, peripheral monocytosis 24 h after the onset of MI has been associated with the development of LV dysfunction and LV aneurysm (124). However, the prognostic role of leukocytosis in heart failure independent of ischemic heart has not been well studied.

In a study of 211 patients with heart failure referred for cardiac transplantation, Ommen et al. (125) found that survival was significantly lower for patients with a low-percentage lymphocyte count, defined as a lymphocyte count of  $< 20.3\%$ , compared with those with a normal-percentage lymphocyte count. NYHA class and percentage lymphocyte count were both independent predictors of survival. They hypothesized that the physiological





**Fig. 6.** Kaplan-Meier survival plot for 159 patients with chronic heart failure. Patients were subgrouped according to ESR. The group of patients with high ESR ( $\geq 15$  mm/h) had an impaired survival compared with patients with an ESR  $< 15$  mm/h (RR: 2.62; 95% confidence interval: 1.58–4.36;  $p < 0.0001$ ). (Reproduced from ref. 20 with permission of the American College of Cardiology and Elsevier Science Inc. ©2000.)

stress experienced by patients with heart failure may result in an increased production of cortisol and a shift in the leukocyte differential toward a decreased percentage of lymphocytes. Similarly, in 861 elderly patients enrolled in the CHF Italian Study, Aconfora et al. (126) reported that 38% of the patients had a relative lymphocyte count of  $\leq 20\%$ . The 3-yr all-cause mortality in patients with heart failure and a low lymphocyte count was 64% compared with 40% in patients with a normal relative lymphocyte count ( $p < 0.0001$ ). Together, the findings of these studies raise the possibility that a low relative lymphocyte count is an independent marker of poor prognosis in patients with heart failure.

### USE OF INFLAMMATORY BIOMARKERS IN MANAGEMENT OF PATIENTS WITH HEART FAILURE

Although the development of clinical practice guidelines and disease management strategies for patients with heart failure has resulted in dramatic overall improvements in patient care and outcomes, the day-to-day management of individual patients with heart failure remains challenging. This difficulty is partly owing to the fact that heart failure management is quite complex, involving numerous therapies, including but not limited to, life style modification with diet and exercise, defibrillator or pacing devices, remodeling surgery, and medications that need to be uptitrated to clinical proven doses and may have side effects limiting their utilization. Furthermore, there may be racial, gender, and age-specific differences in the manner that patients respond to these therapies. Thus, there is a need for additional tools to help individualize management strategies and guide appropriate selection, timing, and/or dosing of therapies in patients with heart failure (127).

Data from large-scale, well-designed clinical studies provide evidence that changes in neurohormonal levels over time are associated with changes in morbidity and mortality in patients with heart failure (128,129). However, at the present time, it is not clear whether

Table 3  
Role of Inflammatory Biomarkers in Heart Failure

	<i>Inflammatory biomarker (prototype marker[s] in heart failure)<sup>a</sup></i>					
	<i>Proinflammatory cytokines (TNF-<math>\alpha</math>, IL-6)</i>	<i>Chemokines (MCP-1)</i>	<i>Cell adhesion molecules (ICAM-1)</i>	<i>CRP</i>	<i>ESR</i>	<i>Leukocyte subsets (lymphopenia, monocytosis)</i>
Involved in pathogenesis of heart failure Supporting references	+++ (3,20,46–51, 54–58,73)	++ (4,65,98–100)	+ (102,103)	n/d	n/d	n/d
Elevated circulating levels in heart failure Supporting references	+++ (1,8,9,17–31, 61,71,72,74)	+ (4)	+ (101,105–107)	++ (109,111,112)	++ (116,120)	+ (126) <sup>d</sup>
Correlation of levels with the severity of disease Supporting references	+++ (1,8,17–20,24,25, 31,59,61,68,70–72)	+ (4)	+ (101,105)	++ (109,112)	n/d	n/d
Correlation of levels with prognosis and heart failure outcomes Supporting references	+++ (22,28,31,71,74–77)	n/d	+ (105)	++ (110–113)	+ (116,120) <sup>c</sup>	+ (125,126)
Development of heart failure in asymptomatic patients predicted by levels Supporting references	++ (70)	n/d	n/d	++ (70)	n/d	n/d
Change in levels with standard heart failure therapy Supporting references	++ (28,75,79,80,82–88)	n/d	n/d	+ (114)	n/d	n/d
Potential target for antagonism in treatment of heart failure <sup>b</sup> Supporting references	++ (12,13,45,91)	n/d	n/d	n/d	n/d	n/d

<sup>a</sup>+++ , supported by large number of studies and more than one large-scale clinical trial; ++ , supported by several studies and/or small-scale clinical trials and/or one large-scale clinical trial; + , supported by one small study or one small clinical trial; n/d , no data available.

<sup>b</sup>Randomized clinical trial results have revealed negative results (12,13).

<sup>c</sup>One study suggested that elevated levels were associated with increased mortality (120), and the other study suggested that elevated levels were associated with better prognosis (116).

<sup>d</sup>There is relative lymphopenia in heart failure.

clinicians should use changes in levels of these biomarkers, such as plasma norepinephrine levels and/or brain natriuretic peptide, to guide heart failure management (127). Furthermore, currently there are no similar data from large-scale studies of the changes in inflammatory biomarkers.

To be useful for application in a general population, a screening test should be sensitive, accurate, reliable, easily standardized, and inexpensive. The assay should be relatively easy to perform and analyze so that the information is readily available to the clinician while the patient is still in the treatment area. The inflammatory biomarkers currently do not fulfill these criteria. The clinical utility of these markers beyond presently available tools remains to be proven, the assays of cytokines or chemokines are not uniformly standardized, and the degree of natural variability in circulating cytokine levels increases with time in patients with heart failure (72). Thus, the concept of utilization of inflammatory biomarkers to guide therapy in heart failure remains investigational at present.

## CONCLUSION

Heart failure is characterized by an ongoing inflammatory response. Inflammatory biomarkers that may be useful in patients with heart failure include biologically active molecules, such as proinflammatory cytokines and chemokines, which are involved in the pathogenesis and progression of heart failure, and others that reflect severity of inflammation, such as CRP and ESR. Most of these biomarkers correlate with severity of disease, prognosis, and clinical outcomes in heart failure. Table 3 provides a summary of the inflammatory biomarkers implicated in heart failure and whether they are involved in the pathogenesis of heart failure; whether the levels are elevated in heart failure; whether the levels correlate with severity of disease or prognosis in heart failure; whether they predict the development of heart failure in asymptomatic patients; whether the levels change with heart failure therapy; and, finally, whether the biomarkers are potential targets for therapy. Despite the wealth of information on inflammation in the pathogenesis and progression in heart failure, the role of inflammatory biomarkers in guiding therapy in heart failure awaits further investigation.

## REFERENCES

1. Levine B, Kalman J, Mayer L, Fillit HM, Packer M. Elevated circulating levels of tumor necrosis factor in severe chronic heart failure. *N Engl J Med* 1990;323(4):236–241.
2. Lower R. *Tractatus de Corde: De Motu & Colore Sanguinis et Chyli in Eum Tranfitu*, 1st ed. Jacobi Allefry, London, UK, 1669.
3. Bozkurt B, Kribbs SB, Clubb FJ Jr, et al. Pathophysiologically relevant concentrations of tumor necrosis factor- $\alpha$  promote progressive left ventricular dysfunction and remodeling in rats. *Circulation* 1998;97(14):1382–1391.
4. Aukrust P, Ueland T, Muller F, et al. Elevated circulating levels of C-C chemokines in patients with congestive heart failure. *Circulation* 1998;97(12):1136–1143.
5. Mann DL. Inflammatory mediators and the failing heart: past, present, and the foreseeable future. *Circ Res* 2002;91(11):988–998.
6. Mann DL. Recent insights into the role of tumor necrosis factor in the failing heart. *Heart Fail Rev* 2001; 6(2):71–80.
7. Kapadia S, Dibbs Z, Kurrelmeyer K, et al. The role of cytokines in the failing human heart. *Cardiol Clin* 1998;16(4):645–656, viii.
8. Torre-Amione G, Kapadia S, Benedict C, Oral H, Young JB, Mann DL. Proinflammatory cytokine levels in patients with depressed left ventricular ejection fraction: a report from the Studies of Left Ventricular Dysfunction (SOLVD). *J Am Coll Cardiol* 1996;27(5):1201–1206.
9. Torre-Amione G, Kapadia S, Lee J, et al. Tumor necrosis factor- $\alpha$  and tumor necrosis factor receptors in the failing human heart. *Circulation* 1996;93(4):704–711.

10. Kapadia SR, Yakoob K, Nader S, Thomas JD, Mann DL, Griffin BP. Elevated circulating levels of serum tumor necrosis factor- $\alpha$  in patients with hemodynamically significant pressure and volume overload. *J Am Coll Cardiol* 2000;36(1):208–212.
11. Finkel MS, Oddis CV, Jacob TD, Watkins SC, Hattler BG, Simmons RL. Negative inotropic effects of cytokines on the heart mediated by nitric oxide. *Science* 1992;257(5068):387–389.
12. Mann DL, McMurray JJ, Packer M, et al. Targeted anticytokine therapy in patients with chronic heart failure: results of the Randomized Etanercept Worldwide Evaluation (RENEWAL). *Circulation* 2004;109(13):1594–1602.
13. Chung ES, Packer M, Lo KH, Fasanmade AA, Willerson JT. Randomized, double-blind, placebo-controlled, pilot trial of infliximab, a chimeric monoclonal antibody to tumor necrosis factor- $\alpha$ , in patients with moderate-to-severe heart failure: results of the anti-TNF Therapy Against Congestive Heart Failure (ATTACH) trial. *Circulation* 2003;107(25):3133–3140.
14. Mann DL, Young JB. Basic mechanisms in congestive heart failure: recognizing the role of proinflammatory cytokines. *Chest* 1994;105(3):897–904.
15. Nathan C, Sporn M. Cytokines in context. *J Cell Biol* 1991;113(5):981–986.
16. Torre-Amione G, Kapadia S, Lee J, Bies RD, Lebovitz R, Mann DL. Expression and functional significance of tumor necrosis factor receptors in human myocardium. *Circulation* 1995;92(6):1487–1493.
17. McMurray J, Abdullah I, Dargie HJ, Shapiro D. Increased concentrations of tumour necrosis factor in “cachectic” patients with severe chronic heart failure. *Br Heart J* 1991;66(5):356–358.
18. Matsumori A, Yamada T, Suzuki H, Matoba Y, Sasayama S. Increased circulating cytokines in patients with myocarditis and cardiomyopathy. *Br Heart J* 1994;72(6):561–566.
19. Dutka DP, Elborn JS, Delamere F, Shale DJ, Morris GK. Tumour necrosis factor  $\alpha$  in severe congestive cardiac failure. *Br Heart J* 1993;70(2):141–143.
20. Katz SD, Rao R, Berman JW, et al. Pathophysiological correlates of increased serum tumor necrosis factor in patients with congestive heart failure: relation to nitric oxide-dependent vasodilation in the forearm circulation. *Circulation* 1994;90(1):12–16.
21. Wiedermann CJ, Beimpold H, Herold M, Knapp E, Braunsteiner H. Increased levels of serum neopterin and decreased production of neutrophil superoxide anions in chronic heart failure with elevated levels of tumor necrosis factor- $\alpha$ . *J Am Coll Cardiol* 1993;22(7):1897–1901.
22. Ferrari R, Bachetti T, Confortini R, et al. Tumor necrosis factor soluble receptors in patients with various degrees of congestive heart failure. *Circulation* 1995;92(6):1479–1486.
23. Milani RV, Mehra MR, Endres S, et al. The clinical relevance of circulating tumor necrosis factor- $\alpha$  in acute decompensated chronic heart failure without cachexia. *Chest* 1996;110(4):992–995.
24. Munger MA, Johnson B, Amber IJ, Callahan KS, Gilbert EM. Circulating concentrations of proinflammatory cytokines in mild or moderate heart failure secondary to ischemic or idiopathic dilated cardiomyopathy. *Am J Cardiol* 1996;77(9):723–727.
25. Testa M, Yeh M, Lee P, et al. Circulating levels of cytokines and their endogenous modulators in patients with mild to severe congestive heart failure due to coronary artery disease or hypertension. *J Am Coll Cardiol* 1996;28(4):964–971.
26. Anker SD, Chua TP, Ponikowski P, et al. Hormonal changes and catabolic/anabolic imbalance in chronic heart failure and their importance for cardiac cachexia. *Circulation* 1997;96(2):526–534.
27. MacGowan GA, Mann DL, Kormos RL, Feldman AM, Murali S. Circulating interleukin-6 in severe heart failure. *Am J Cardiol* 1997;79(8):1128–1131.
28. Mohler ER III, Sorensen LC, Ghali JK, et al. Role of cytokines in the mechanism of action of amlodipine: the PRAISE Heart Failure Trial. Prospective Randomized Amlodipine Survival Evaluation. *J Am Coll Cardiol* 1997;30(1):35–41.
29. Nishigaki K, Minatoguchi S, Seishima M, et al. Plasma Fas ligand, an inducer of apoptosis, and plasma soluble Fas, an inhibitor of apoptosis, in patients with chronic congestive heart failure. *J Am Coll Cardiol* 1997;29(6):1214–1220.
30. Anker SD, Egerer KR, Volk HD, Kox WJ, Poole-Wilson PA, Coats AJ. Elevated soluble CD14 receptors and altered cytokines in chronic heart failure. *Am J Cardiol* 1997;79(10):1426–1430.
31. Deswal A, Petersen NJ, Feldman AM, Young JB, White BG, Mann DL. Cytokines and cytokine receptors in advanced heart failure: an analysis of the cytokine database from the Vesnarinone trial (VEST). *Circulation* 2001;103(16):2055–2059.
32. de Werra I, Jaccard C, Corradin SB, et al. Cytokines, nitrite/nitrate, soluble tumor necrosis factor receptors, and procalcitonin concentrations: comparisons in patients with septic shock, cardiogenic shock, and bacterial pneumonia. *Crit Care Med* 1997;25(4):607–613.

33. Coley WB. The treatment of malignant tumors by repeated inoculations of erysipelas. With a report of ten original cases. 1893. *Clin Orthop* 1991;262:3–11.
34. O'Malley WE, Achinstein B, Shear MJ. Journal of the National Cancer Institute, Vol. 29, 1962: Action of bacterial polysaccharide on tumors. II. Damage of sarcoma 37 by serum of mice treated with *Serratia marcescens* polysaccharide, and induced tolerance. *Nutr Rev* 1988;46(11):389–391.
35. Carswell EA, Old LJ, Kassel RL, Green S, Fiore N, Williamson B. An endotoxin-induced serum factor that causes necrosis of tumors. *Proc Natl Acad Sci USA* 1975;72(9):3666–3670.
36. Beutler B, Greenwald D, Hulmes JD, et al. Identity of tumour necrosis factor and the macrophage-secreted factor cachectin. *Nature* 1985;316(6028):552–554.
37. Aggarwal BB. Signalling pathways of the TNF superfamily: a double-edged sword. *Nat Rev Immunol* 2003;3(9):745–756.
38. Lefer AM, Rovetto MJ. Influence of a myocardial depressant factor on physiologic properties of cardiac muscle. *Proc Soc Exp Biol Med* 1970;134(1):269–273.
39. Parrillo JE. Pathogenetic mechanisms of septic shock. *N Engl J Med* 1993;328(20):1471–1477.
40. Kumar A, Thota V, Dee L, Olson J, Uretz E, Parrillo JE. Tumor necrosis factor alpha and interleukin 1beta are responsible for in vitro myocardial cell depression induced by human septic shock serum. *J Exp Med* 1996;183(3):949–958.
41. Old LJ. Tumor necrosis factor (TNF). *Science* 1985;230(4726):630–632.
42. Yokoyama T, Vaca L, Rossen RD, Durante W, Hazarika P, Mann DL. Cellular basis for the negative inotropic effects of tumor necrosis factor-alpha in the adult mammalian heart. *J Clin Invest* 1993;92(5):2303–2312.
43. Gulick T, Chung MK, Pieper SJ, Lange LG, Schreiner GF. Interleukin 1 and tumor necrosis factor inhibit cardiac myocyte beta-adrenergic responsiveness. *Proc Natl Acad Sci USA* 1989;86(17):6753–6757.
44. Giroir BP, Johnson JH, Brown T, Allen GL, Beutler B. The tissue distribution of tumor necrosis factor biosynthesis during endotoxemia. *J Clin Invest* 1992;90(3):693–698.
45. Bozkurt B, Torre-Amione G, Warren MS, et al. Results of targeted anti-tumor necrosis factor therapy with etanercept (ENBREL) in patients with advanced heart failure. *Circulation* 2001;103(8):1044–1047.
46. Tracey KJ, Beutler B, Lowry SF, et al. Shock and tissue injury induced by recombinant human cachectin. *Science* 1986;234(4775):470–474.
47. Pagani FD, Baker LS, Hsi C, Knox M, Fink MP, Visner MS. Left ventricular systolic and diastolic dysfunction after infusion of tumor necrosis factor-alpha in conscious dogs. *J Clin Invest* 1992;90(2):389–398.
48. Kubota T, McTiernan CF, Frye CS, et al. Dilated cardiomyopathy in transgenic mice with cardiac-specific overexpression of tumor necrosis factor-alpha. *Circ Res* 1997;81(4):627–635.
49. Franco F, Thomas GD, Giroir B, et al. Magnetic resonance imaging and invasive evaluation of development of heart failure in transgenic mice with myocardial expression of tumor necrosis factor-alpha. *Circulation* 1999;99(3):448–454.
50. Hosenpud JD, Campbell SM, Mendelson DJ. Interleukin-1-induced myocardial depression in an isolated beating heart preparation. *J Heart Transplant* 1989;8(6):460–464.
51. Kinugawa K, Takahashi T, Kohmoto O, et al. Nitric oxide-mediated effects of interleukin-6 on  $[Ca^{2+}]_i$  and cell contraction in cultured chick ventricular myocytes. *Circ Res* 1994;75(2):285–295.
52. Kelly RA, Smith TW. Cytokines and cardiac contractile function. *Circulation* 1997;95(4):778–781.
53. Dinarello CA. Interleukin-18. *Methods* 1999;19(1):121–132.
54. Krown KA, Page MT, Nguyen C, et al. Tumor necrosis factor alpha-induced apoptosis in cardiac myocytes: involvement of the sphingolipid signaling cascade in cardiac cell death. *J Clin Invest* 1996;98(12):2854–2865.
55. Li YY, Feng YQ, Kadokami T, et al. Myocardial extracellular matrix remodeling in transgenic mice overexpressing tumor necrosis factor alpha can be modulated by anti-tumor necrosis factor alpha therapy. *Proc Natl Acad Sci USA* 2000;97(23):12,746–12,751.
56. Bryant D, Becker L, Richardson J, et al. Cardiac failure in transgenic mice with myocardial expression of tumor necrosis factor-alpha. *Circulation* 1998;97(14):1375–1381.
57. Sivasubramanian N, Coker ML, Kurrelmeyer KM, et al. Left ventricular remodeling in transgenic mice with cardiac restricted overexpression of tumor necrosis factor. *Circulation* 2001;104(7):826–831.
58. Murray DR, Freeman GL. Tumor necrosis factor-alpha induces a biphasic effect on myocardial contractility in conscious dogs. *Circ Res* 1996;78(1):154–160.
59. Seta Y, Shan K, Bozkurt B, Oral H, Mann DL. Basic mechanisms in heart failure: the cytokine hypothesis. *J Card Fail* 1996;2(3):243–249.

60. Plenz G, Song ZF, Tjan TD, et al. Activation of the cardiac interleukin-6 system in advanced heart failure. *Eur J Heart Fail* 2001;3(4):415–421.
61. Aukrust P, Ueland T, Lien E, et al. Cytokine network in congestive heart failure secondary to ischemic or idiopathic dilated cardiomyopathy. *Am J Cardiol* 1999;83(3):376–382.
62. Bachetti T, Comini L, Pasini E, Ferrari R. Anti-cytokine therapy in chronic heart failure: new approaches and unmet promises. *Eur Heart J Suppl* 2004;6(Suppl F):F16–F21.
63. Heinrich PC, Behrmann I, Muller-Newen G, Schaper F, Graeve L. Interleukin-6-type cytokine signaling through the gp130/Jak/STAT pathway. *Biochem J* 1998;334(Pt 2):297–314.
64. Francis SE, Holden H, Holt CM, Duff GW. Interleukin-1 in myocardium and coronary arteries of patients with dilated cardiomyopathy. *J Mol Cell Cardiol* 1998;30(2):215–223.
65. Shioi T, Matsumori A, Kihara Y, et al. Increased expression of interleukin-1 beta and monocyte chemoattractant and activating factor/monocyte chemoattractant protein-1 in the hypertrophied and failing heart with pressure overload. *Circ Res* 1997;81(5):664–671.
66. Long CS. The role of interleukin-1 in the failing heart. *Heart Fail Rev* 2001;6(2):81–94.
67. Palmer JN, Hartogensis WE, Patten M, Fortuin FD, Long CS. Interleukin-1 beta induces cardiac myocyte growth but inhibits cardiac fibroblast proliferation in culture. *J Clin Invest* 1995;95(6):2555–2564.
68. Anker SD, Ponikowski PP, Clark AL, et al. Cytokines and neurohormones relating to body composition alterations in the wasting syndrome of chronic heart failure. *Eur Heart J* 1999;20(9):683–693.
69. Niebauer J, Volk HD, Kemp M, et al. Endotoxin and immune activation in chronic heart failure: a prospective cohort study. *Lancet* 1999;353(9167):1838–1842.
70. Vasan RS, Sullivan LM, Roubenoff R, et al. Inflammatory markers and risk of heart failure in elderly subjects without prior myocardial infarction: the Framingham Heart Study. *Circulation* 2003;107(11):1486–1491.
71. Tsutamoto T, Hisanaga T, Wada A, et al. Interleukin-6 spillover in the peripheral circulation increases with the severity of heart failure, and the high plasma level of interleukin-6 is an important prognostic predictor in patients with congestive heart failure. *J Am Coll Cardiol* 1998;31(2):391–398.
72. Dibbs Z, Thornby J, White BG, Mann DL. Natural variability of circulating levels of cytokines and cytokine receptors in patients with heart failure: implications for clinical trials. *J Am Coll Cardiol* 1999;33(7):1935–1942.
73. Satoh M, Nakamura M, Saitoh H, et al. Tumor necrosis factor-alpha-converting enzyme and tumor necrosis factor-alpha in human dilated cardiomyopathy. *Circulation* 1999;99(25):3260–3265.
74. Rauchhaus M, Doehner W, Francis DP, et al. Plasma cytokine parameters and mortality in patients with chronic heart failure. *Circulation* 2000;102(25):3060–3067.
75. Maeda K, Tsutamoto T, Wada A, et al. High levels of plasma brain natriuretic peptide and interleukin-6 after optimized treatment for heart failure are independent risk factors for morbidity and mortality in patients with congestive heart failure. *J Am Coll Cardiol* 2000;36(5):1587–1593.
76. Kell R, Haunstetter A, Dengler TJ, Zugck C, Kubler W, Haass M. Do cytokines enable risk stratification to be improved in NYHA functional class III patients? Comparison with other potential predictors of prognosis. *Eur Heart J* 2002;23(1):70–78.
77. Ferrari R. Interleukin-6: a neurohumoral predictor of prognosis in patients with heart failure: light and shadow. *Eur Heart J* 2002;23(1):9, 10.
78. Hernandez-Presa M, Bustos C, Ortego M, et al. Angiotensin-converting enzyme inhibition prevents arterial nuclear factor-kappa B activation, monocyte chemoattractant protein-1 expression, and macrophage infiltration in a rabbit model of early accelerated atherosclerosis. *Circulation* 1997;95(6):1532–1541.
79. Wei GC, Sirois MG, Qu R, Liu P, Rouleau JL. Subacute and chronic effects of quinapril on cardiac cytokine expression, remodeling, and function after myocardial infarction in the rat. *J Cardiovasc Pharmacol* 2002;39(6):842–850.
80. Gurlek A, Kilickap M, Dincer I, Dandachi R, Tutkak H, Oral D. Effect of losartan on circulating TNF alpha levels and left ventricular systolic performance in patients with heart failure. *J Cardiovasc Risk* 2001;8(5):279–282.
81. Prabhu SD, Chandrasekar B, Murray DR, Freeman GL. Beta-adrenergic blockade in developing heart failure: effects on myocardial inflammatory cytokines, nitric oxide, and remodeling. *Circulation* 2000;101(17):2103–2109.
82. Aronson D, Burger AJ. Effect of beta-blockade on autonomic modulation of heart rate and neurohormonal profile in decompensated heart failure. *Ann Noninvasive Electrocardiol* 2001;6(2):98–106.

83. Ohtsuka T, Hamada M, Hiasa G, et al. Effect of beta-blockers on circulating levels of inflammatory and anti-inflammatory cytokines in patients with dilated cardiomyopathy. *J Am Coll Cardiol* 2001; 37(2):412–417.
84. Gage JR, Fonarow G, Hamilton M, Widawski M, Martinez-Maza O, Vredevoe DL. Beta blocker and angiotensin-converting enzyme inhibitor therapy is associated with decreased Th1/Th2 cytokine ratios and inflammatory cytokine production in patients with chronic heart failure. *Neuroimmunomodulation* 2004;11(3):173–180.
85. Loppnow H, Werdan K, Werner C. The enhanced plasma levels of soluble tumor necrosis factor receptors (sTNF-R1; sTNF-R2) and interleukin-10 (IL-10) in patients suffering from chronic heart failure are reversed in patients treated with beta-adrenoceptor antagonist. *Auton Autacoid Pharmacol* 2002;22(2):83–92.
86. Matsumura T, Tsushima K, Ohtaki E, et al. Effects of carvedilol on plasma levels of interleukin-6 and tumor necrosis factor-alpha in nine patients with dilated cardiomyopathy. *J Cardiol* 2002;39(5):253–257.
87. Tsutamoto T, Wada A, Matsumoto T, et al. Relationship between tumor necrosis factor-alpha production and oxidative stress in the failing hearts of patients with dilated cardiomyopathy. *J Am Coll Cardiol* 2001;37(8):2086–2092.
88. Gullestad L, Aukrust P, Ueland T, et al. Effect of high-versus low-dose angiotensin converting enzyme inhibition on cytokine levels in chronic heart failure. *J Am Coll Cardiol* 1999;34(7):2061–2067.
89. Torre-Amione G, Stetson SJ, Youker KA, et al. Decreased expression of tumor necrosis factor-alpha in failing human myocardium after mechanical circulatory support: a potential mechanism for cardiac recovery. *Circulation* 1999;100(11):1189–1193.
90. Kapadia S, Torre-Amione G, Yokoyama T, Mann DL. Soluble TNF binding proteins modulate the negative inotropic properties of TNF-alpha in vitro. *Am J Physiol* 1995;268(2 Pt 2):H517–H525.
91. Deswal A, Bozkurt B, Seta Y, et al. Safety and efficacy of a soluble P75 tumor necrosis factor receptor (Enbrel, etanercept) in patients with advanced heart failure. *Circulation* 1999;99(25):3224–3226.
92. Raymond RJ, Dehmer GJ, Theoharides TC, Deliarogiris EN. Elevated interleukin-6 levels in patients with asymptomatic left ventricular systolic dysfunction. *Am Heart J* 2001;141(3):435–438.
93. Ridker PM, Rifai N, Pfeffer M, Sacks F, Lepage S, Braunwald E. Elevation of tumor necrosis factor-alpha and increased risk of recurrent coronary events after myocardial infarction. *Circulation* 2000;101(18):2149–2153.
94. Ridker PM, Rifai N, Stampfer MJ, Hennekens CH. Plasma concentration of interleukin-6 and the risk of future myocardial infarction among apparently healthy men. *Circulation* 2000;101(15):1767–1772.
95. Murray DR, Freeman GL. Proinflammatory cytokines: predictors of a failing heart? *Circulation* 2003; 107(11):1460–1462.
96. Baggiolini M, Dewald B, Moser B. Interleukin-8 and related chemotactic cytokines—CXC and CC chemokines. *Adv Immunol* 1994;55:97–179.
97. Rollins BJ, Yoshimura T, Leonard EJ, Pober JS. Cytokine-activated human endothelial cells synthesize and secrete a monocyte chemoattractant, MCP-1/JE. *Am J Pathol* 1990;136(6):1229–1233.
98. Behr TM, Wang X, Aiyar N, et al. Monocyte chemoattractant protein-1 is upregulated in rats with volume-overload congestive heart failure. *Circulation* 2000;102(11):1315–1322.
99. Kolattukudy PE, Quach T, Bergese S, et al. Myocarditis induced by targeted expression of the MCP-1 gene in murine cardiac muscle. *Am J Pathol* 1998;152(1):101–111.
100. Damas JK, Eiken HG, Oie E, et al. Myocardial expression of CC- and CXC-chemokines and their receptors in human end-stage heart failure. *Cardiovasc Res* 2000;47(4):778–787.
101. Devaux B, Scholz D, Hirche A, Klovekorn WP, Schaper J. Upregulation of cell adhesion molecules and the presence of low grade inflammation in human chronic heart failure. *Eur Heart J* 1997;18(3):470–479.
102. Frenette PS, Wagner DD. Adhesion molecules—Part I: Blood vessels and blood cells. *N Engl J Med* 1996;334(23):1526–1529.
103. Frenette PS, Wagner DD. Adhesion molecules—Part II: Blood vessels and blood cells. *N Engl J Med* 1996;335(1):43–45.
104. Anker SD, von Haehling S. Inflammatory mediators in chronic heart failure: an overview. *Heart* 2004; 90(4):464–470.
105. Tsutamoto T, Hisanaga T, Fukai D, et al. Prognostic value of plasma soluble intercellular adhesion molecule-1 and endothelin-1 concentration in patients with chronic congestive heart failure. *Am J Cardiol* 1995;76(11):803–808.
106. Andreassen AK, Nordoy I, Simonsen S, et al. Levels of circulating adhesion molecules in congestive heart failure and after heart transplantation. *Am J Cardiol* 1998;81(5):604–608.

107. Tousoulis D, Homaei H, Ahmed N, et al. Increased plasma adhesion molecule levels in patients with heart failure who have ischemic heart disease and dilated cardiomyopathy. *Am Heart J* 2001;141(2):277–280.
108. Black S, Kushner I, Samols D. C-reactive protein. *J Biol Chem* 2004;279(47):48,487–48,490.
109. Pye M, Rae AP, Cobbe SM. Study of serum C-reactive protein concentration in cardiac failure. *Br Heart J* 1990;63(4):228–230.
110. Kaneko K, Kanda T, Yamauchi Y, et al. C-Reactive protein in dilated cardiomyopathy. *Cardiology* 1999; 91(4):215–219.
111. Milo O, Cotter G, Kaluski E, et al. Comparison of inflammatory and neurohormonal activation in cardiogenic pulmonary edema secondary to ischemic versus nonischemic causes. *Am J Cardiol* 2003;92(2): 222–226.
112. Alonso-Martinez JL, Llorente-Diez B, Echegaray-Agara M, Olaz-Preciado F, Urbietta-Echezarreta M, Gonzalez-Arencibia C. C-reactive protein as a predictor of improvement and readmission in heart failure. *Eur J Heart Fail* 2002;4(3):331–336.
113. Cesari M, Penninx BW, Newman AB, et al. Inflammatory markers and onset of cardiovascular events: results from the Health ABC study. *Circulation* 2003;108(19):2317–2322.
114. Joynt KE, Gattis WA, Hasselblad V, et al. Effect of angiotensin-converting enzyme inhibitors, beta blockers, statins, and aspirin on C-reactive protein levels in outpatients with heart failure. *Am J Cardiol* 2004;93(6):783–785.
115. Wood P. The erythrocyte sedimentation rate in diseases of the heart. *Q J Med* 1936;5:1–19.
116. Haber HL, Leavy JA, Kessler PD, Kukin ML, Gottlieb SS, Packer M. The erythrocyte sedimentation rate in congestive heart failure. *N Engl J Med* 1991;324(6):353–358.
117. Spinazzola A. [On the behavior of erythrocyte sedimentation rate (E.S.R.) in congestive heart failure]. *Rass Med Sarda* 1961;63:525–533.
118. Parry EH. The erythrocyte sedimentation rate in heart failure. *Acta Med Scand* 1961;169:79–85.
119. McGinnis AE, Lansche WE, Glaser RJ, Loeb LH. Observations on the erythrocyte sedimentation rate in congestive heart failure. *Am J Med Sci* 1953;225(6):599–604.
120. Sharma R, Rauchhaus M, Ponikowski PP, et al. The relationship of the erythrocyte sedimentation rate to inflammatory cytokines and survival in patients with chronic heart failure treated with angiotensin-converting enzyme inhibitors. *J Am Coll Cardiol* 2000;36(2):523–528.
121. Furman MI, Gore JM, Anderson FA, et al. Elevated leukocyte count and adverse hospital events in patients with acute coronary syndromes: findings from the Global Registry of Acute Coronary Events (GRACE). *Am Heart J* 2004;147(1):42–48.
122. Menon V, Lessard D, Yarzebski J, Furman MI, Gore JM, Goldberg RJ. Leukocytosis and adverse hospital outcomes after acute myocardial infarction. *Am J Cardiol* 2003;92(4):368–372.
123. Kyne L, Hausdorff JM, Knight E, Dukas L, Azhar G, Wei JY. Neutrophilia and congestive heart failure after acute myocardial infarction. *Am Heart J* 2000;139(1 Pt 1):94–100.
124. Maekawa Y, Anzai T, Yoshikawa T, et al. Prognostic significance of peripheral monocytosis after reperfused acute myocardial infarction: a possible role for left ventricular remodeling. *J Am Coll Cardiol* 2002; 39(2):241–246.
125. Ommen SR, Hodge DO, Rodeheffer RJ, McGregor CG, Thomson SP, Gibbons RJ. Predictive power of the relative lymphocyte concentration in patients with advanced heart failure. *Circulation* 1998;97(1): 19–22.
126. Acanfora D, Gheorghiane M, Trojano L, et al. Relative lymphocyte count: a prognostic indicator of mortality in elderly patients with congestive heart failure. *Am Heart J* 2001;142(1):167–173.
127. Bozkurt B, Mann DL. Use of biomarkers in the management of heart failure: are we there yet? *Circulation* 2003;107(9):1231–1233.
128. Anand IS, Fisher LD, Chiang YT, et al. Changes in brain natriuretic peptide and norepinephrine over time and mortality and morbidity in the Valsartan Heart Failure Trial (Val-HeFT). *Circulation* 2003; 107(9):1278–1283.
129. Cohn JN, Anand IS, Latini R, Masson S, Chiang YT, Glazer R. Sustained reduction of aldosterone in response to the angiotensin receptor blocker valsartan in patients with chronic heart failure: results from the Valsartan Heart Failure Trial. *Circulation* 2003;108(11):1306–1309.
130. Suffredini AF, Fromm RE, Parker MM, et al. The cardiovascular response of normal humans to the administration of endotoxin. *N Engl J Med* 1989;321(5):280–287.
131. Millar AB, Foley NM, Singer M, Johnson NM, Meager A, Rook GA. Tumour necrosis factor in bronchopulmonary secretions of patients with adult respiratory distress syndrome. *Lancet* 1989;2(8665):712–714.
132. Hegewisch S, Weh HJ, Hossfeld DK. TNF-induced cardiomyopathy. *Lancet* 1990;335(8684):294, 295.



133. Semb H, Peterson J, Tavernier J, Olivecrona T. Multiple effects of tumor necrosis factor on lipoprotein lipase in vivo. *J Biol Chem* 1987;262(17):8390–8394.
134. Oliff A, Defeo-Jones D, Boyer M, et al. Tumors secreting human TNF/cachectin induce cachexia in mice. *Cell* 1987;50(4):555–563.
135. Chung MK, Gulick TS, Rotondo RE, Schreiner GF, Lange LG. Mechanism of cytokine inhibition of beta-adrenergic agonist stimulation of cyclic AMP in rat cardiac myocytes: impairment of signal transduction. *Circ Res* 1990;67(3):753–763.
136. Lancaster JR Jr, Laster SM, Gooding LR. Inhibition of target cell mitochondrial electron transfer by tumor necrosis factor. *FEBS Lett* 1989;248(1–2):169–174.
137. Thaik CM, Calderone A, Takahashi N, Colucci WS. Interleukin-1 beta modulates the growth and phenotype of neonatal rat cardiac myocytes. *J Clin Invest* 1995;96(2):1093–1099.
138. Engel D, Peshock R, Armstrong RC, Sivasubramanian N, Mann DL. Cardiac myocyte apoptosis provokes adverse cardiac remodeling in transgenic mice with targeted TNF overexpression. *Am J Physiol Heart Circ Physiol* 2004;287(3):H1303–H1311.

# 20

---

## Biomarkers of Infection and Risk of Coronary Heart Disease

---

*Joseph B. Muhlestein, MD*

### CONTENTS

INTRODUCTION
<i>CHLAMYDIA PNEUMONIAE</i>
<i>HELICOBACTER PYLORI</i>
<i>MYCOPLASMA PNEUMONIAE</i>
CYTOMEGALOVIRUS
OTHER HERPESVIRUSES
HUMAN IMMUNODEFICIENCY VIRUS
INFLUENZA VIRUS
TOTAL PATHOGEN BURDEN AS AN AGGREGATE SEROLOGICAL RISK FACTOR
CLINICAL USE OF INFECTIOUS MARKERS FOR RISK STRATIFICATION: NOT YET READY FOR PRIME TIME
CONCLUSION
REFERENCES

---

### SUMMARY

Chronic infection has been found to be significantly associated with the development of atherosclerosis and the clinical complications of unstable angina, myocardial infarction, and stroke. A variety of infectious agents have been proposed to be involved in atherothrombosis, and, indeed, the number of implicated agents continues to increase each year. These include specific bacterial and viral agents, as well as a variety of agents associated with periodontal disease. However, failure to confirm initial reports of serological associations also has been common. The infectious agents with the most evidence to support an etiological role in atherosclerosis include *Chlamydia pneumoniae* and cytomegalovirus. In addition, evidence is mounting for a variety of other potential agents including other herpes viruses, influenza, other specific bacteria (such as *Mycoplasma pneumoniae*), and chronic infections with common bacterial agents (e.g., periodontal disease, chronic bronchitis, chronic urinary tract infection). Nevertheless, specific causative relationships on par with that determined between *Helicobacter pylori* and peptic ulcer disease have not yet been established. In addition, treatment of some of these pathogens

From: *Contemporary Cardiology:  
Cardiovascular Biomarkers: Pathophysiology and Disease Management*  
Edited by: David A. Morrow © Humana Press Inc., Totowa, NJ

has failed to reduce the risk of cardiovascular complications. Future studies are expected to elucidate further the pathophysiological relationship between chronic infection and atherosclerosis and the potential of a variety of treatment approaches including antibiotics. Until then, however, a general recommendation for the use of any of these infectious markers during routine cardiovascular risk stratification cannot be made.

**Key Words:** Infection; *Chlamydia pneumoniae*; *Helicobacter pylori*; *Mycoplasma pneumoniae*; cytomegalovirus; atherosclerosis.

## INTRODUCTION

Although much is known about the pathological process of atherosclerosis, in many cases the underlying etiology remains unclear. Certain risk factors associated with the development of atherosclerosis are well defined, including diabetes mellitus, hypertension, hyperlipidemia, tobacco abuse, and a positive family history (1). However, these risk factors combined account for only about 50% of the observed incidence of atherosclerosis (2). Additionally, these risk factors generally are only identified as such by association with cardiovascular disease (CVD), and the exact mechanism by which they may contribute to the development of atherosclerosis is not known.

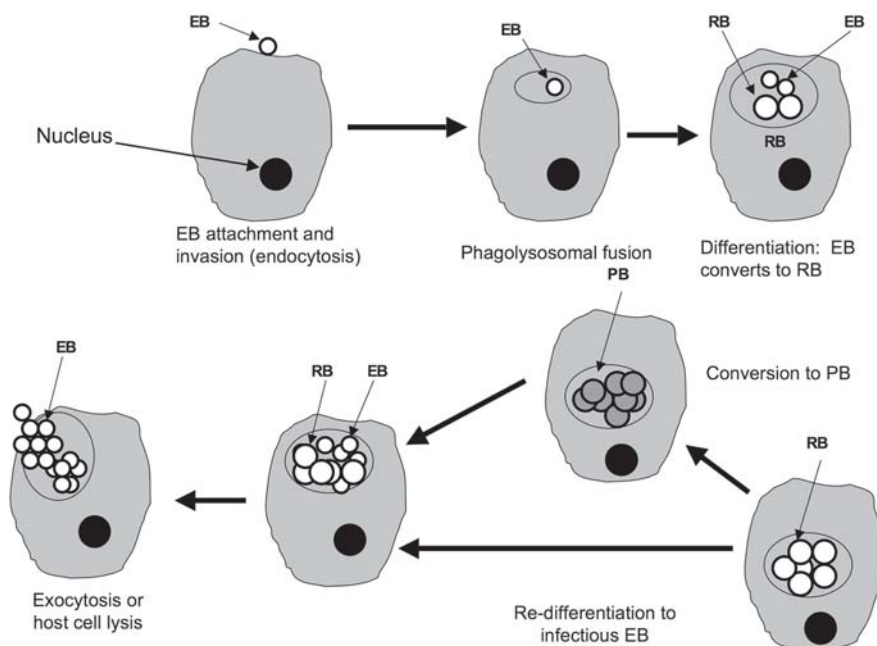
The question of whether infections can cause diffuse and chronic arterial lesions has been debated for many years. This debate has been fueled by the emergence of evidence showing specific associations between atherosclerosis and a number of infectious agents. It has been proposed that a variety of infectious agents are involved in atherothrombosis, and, indeed, the number of implicated agents continues to increase each year. Such agents include specific bacterial and viral agents, as well as various agents associated with periodontal disease. The mechanisms whereby these agents may play a role in the development and progression of atherosclerosis also appear to be many and varied.

In this chapter, I review the reported associations between atherosclerosis and a number of infectious agents. I concentrate on a number of well-documented infectious associations and their related biomarkers. I then comment on the potential clinical utility of these markers in relation to cardiovascular risk.

### *CHLAMYDIA PNEUMONIAE*

*C. pneumoniae* was isolated in 1986 (3). It was found to be responsible for a variety of respiratory illnesses including 10% of cases of community-acquired pneumonia. Like the more familiar *Chlamydia trachomatis*, *C. pneumoniae* is an obligate intracellular pathogen with a unique life cycle (Fig. 1) (4). Generally, *C. pneumoniae* enters the body through a respiratory route and exists outside of cells in a spore form called the elementary body. Once inside the host cell it makes use of the cell's own metabolic machinery and develops into a metabolically active but noninfectious form called the reticulate body. In this form, the bacterium has the ability to divide and differentiate into new elementary bodies, which can then invade other host cells.

*C. pneumoniae* may also unpredictably convert within the cell to a metabolically inactive form called the persistent body (5). In this state, it may remain within the cell for extended periods essentially undetectable by the immune system and unresponsive to antibiotics that interfere with bacterial metabolism. A proposed association between *C. pneumoniae* and atherosclerosis is based on serological evidence, detection of the organism in the blood, pathological evidence, animal models, and therapeutic trials.



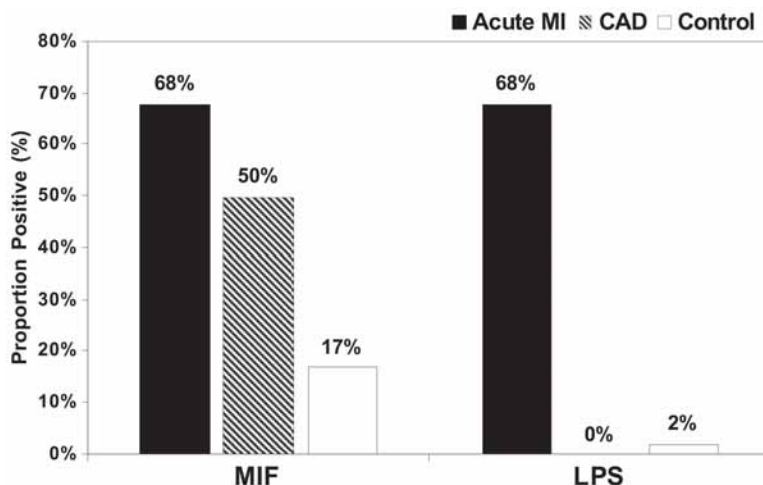
**Fig. 1.** Depiction of traditional life cycle of *C. pneumoniae* (see text for description). EB, elementary body; RB, reticulate body; PB, persistent body.

### Serological Evidence

In 1998, Pekka Saikku and his associates of the University of Helsinki made the first suggestion of an association between *C. pneumoniae* and coronary artery disease (CAD) (6). They had described an epidemic of mild pneumonia caused by what was then considered to be an unusual strain of *Chlamydia psittaci*. Following up on earlier reports linking myocarditis and arterial emboli with chlamydial infection, they measured titers of antibody to *C. pneumoniae*. They discovered that men experiencing acute myocardial infarction (AMI) or with significant CAD were more likely to be seropositive for *C. pneumoniae* than age- and sex-matched control subjects (Fig. 2).

This serological evidence was strengthened later when Saikku et al. (7) evaluated patients in the Helsinki Heart Study, in which hyperlipidemic patients with no previously documented heart disease were randomized to receive gemfibrozil or placebo and followed for the development of MI or cardiovascular death. Patients who were seropositive for *C. pneumoniae* at baseline were 2.6 times more likely to experience CVD during the study than those who were seronegative. Since these initial reports, a large number of serological studies have been performed (Table 1). Based on the largest of these studies, as well as systematic overviews, the association between *C. pneumoniae* seropositivity and CAD appears to be independent but weak. However, a few caveats should be kept in mind when considering the seroepidemiological evidence.

First, in control populations who are similar in age to most patients with CAD ( $\oplus 60$  yr), the incidence of seropositivity to *C. pneumoniae* is often nearly 70% (8). This high incidence of seropositivity in the control population, therefore, makes it difficult to document a significant difference in incidence between the control and the diseased population. One must remember, however, that atherosclerosis, especially when asymptomatic atherosclerosis is included, is nearly ubiquitous in this age population and, therefore, a



**Fig. 2.** Graph showing results of MIF (microimmunofluorescence test for antibodies specifically targeted against *C. pneumoniae*) and LPS (enzyme-linked immunoassay for antibodies against the chlamydial group antigen) assays in patients experiencing AMI in patients with known CAD, and in control subjects (6).

high incidence of seropositivity to *C. pneumoniae* in the control population does not necessarily indicate an absence of an association between atherosclerosis and *C. pneumoniae*.

Second, serological titers of IgG or IgA to *C. pneumoniae* merely reflect having been exposed to the infectious agent sometime in the past. They do not necessarily represent an ongoing chronic infection. Therefore, the presence of patients both in the case and in the control series in which a previous infection occurred but the immune system was capable of complete eradication could contaminate serological results.

Third, the serological techniques used in the various studies have not been well standardized. In an expert panel consensus conference sponsored by the Centers for Disease Control (CDC), Dowell et al. (9) reported that diagnostic testing for *C. pneumoniae* from different laboratories is highly variable and “gold standards” are lacking, leading to calls for more standardized approaches. In addition, the expert panel reviewed the available approaches to serological testing and recommended that only microimmunofluorescence be used. Even though a variety of enzyme-linked immunosorbent assay (ELISAs) were evaluated, none were felt to be adequate. The use of single IgG titers for determining acute infection and IgA for determining chronic infection was also discouraged.

### *Detection of the Organism in the Blood*

Other diagnostic methods are presently being developed in an attempt to distinguish between an ongoing, chronic infection and mere history of exposure to the infectious process (10). In my laboratory, based on the proposition that a chronic, ongoing infection of *C. pneumoniae* might act in a manner similar to that of infectious endocarditis, we tested the buffy coat of patients with coronary disease undergoing coronary angioplasty for the presence of DNA specific for *C. pneumoniae* by polymerase chain reaction (PCR) techniques (11). In this relatively small study, 13% of patients had detectable *C. pneumoniae* DNA within their buffy coat compared with 0% in a control population of healthy blood donors. This study had two interesting observations: (1) some patients with CAD have

Table 1  
Seroepidemiological Evidence of an Association Between Atherosclerosis and *C. pneumoniae*

Author (Reference) and date	Type of study	Population studied	Association
Saikku et al. (6), 1998	Case-control	AMI, CAD	Positive
Leinonen et al. (101), 1990	Case-control	CAD	Positive
Thom et al. (102), 1991	Case-control	CAD	Positive
Saikku et al. (7), 1992	Nested case-control	AMI	Positive
Thom et al. (103), 1992	Case-control	CAD	Positive
Linnanmaki et al. (104), 1993	Case-control	CAD	Positive
Melnick et al. (105), 1993	Case-control	Carotid stenosis	Positive
Puolakkainen et al. (106), 1993	Case-control	CAD	Positive
Saikku et al. (107), 1993	Case-control	AMI	Positive
Dahlen et al. (108), 1995	Case-control	CAD	Positive
Mendall et al. (109), 1995	Case-control	CAD	Positive
Patel et al. (110), 1995	Case-control	CAD	Positive
Cook et al. (111), 1995	Case-control	MI or unstable angina	Positive
Miettinen et al. (112), 1996	Cohort	AMI or CV death	Positive
Wimmer et al. (113), 1996	Case-control	Stroke or TIA	Positive
Ossewaarde et al. (114), 1998	Nested case-control	CAD	Positive
Gupta et al. (115), 1997	Cohort	AMI or CV death	Positive
Blasi et al. (116), 1997	Case-control	AMI	Positive
Kark et al. (117), 1997	Case-control	AMI	Negative
Anderson et al. (8), 1998	Case-control	CAD	Negative
Fagerberg et al. (118), 1999	Cohort	Stroke	Positive
Miyashita et al. (119), 1998	Case-control	CAD	Positive
Altman et al. (120), 1999	Case-control	CAD or AMI	Negative
Ridker et al. (121), 1999	Cohort	AMI or CHD death	Negative
Siscovick et al. (122), 2000	Nested case-control	CAD or MI	Negative
Espinola-Klein et al. (123), 2000	Case-control	Carotid disease	Positive
Mayr et al. (124), 2000	Case-control	Carotid or femoral disease	Positive
Kosaka et al. (125), 2000	Case-control	AMI	Positive
Shimada et al. (126), 2000	Case-control	CAD	Positive
Tontsch et al. (127), 2000	Case-control	CAD	Negative
Hoffmeister et al. (128), 2000	Case-control	CAD	Negative
Song et al. (129), 2000	Case-control	CAD	Positive
Blanchard et al. (130), 2000	Case-control	Aortic aneurysm	Positive
Wald et al. (131), 2000	Cohort	CV death	Negative
Schmidt et al. (132), 2000	Case-control	Carotid disease	Positive
Elkind et al. (133), 2000	Case-control	Stroke	Positive
Romeo et al. (134), 2000	Case-control	CAD	Negative
Sharma et al. (135), 2001	Case-control	Endothelial function	Positive
Smieja et al. (136), 2001	Case-control	CAD or AMI	Positive
Katsenis et al. (137), 2001	Case-control	Carotid disease	Positive
Mendis et al. (138), 2001	Case-control	CAD	Negative
Shimada et al. (139), 2001	Case-control	CAD or AMI	Positive
Haubitz et al. (140), 2001	Case-control/cohort	CAD	Positive
Sander et al. (141), 2001	Cohort	Carotid disease	Positive

AMI, acute myocardial infarction; MI, myocardial infarction; CAD, coronary artery disease; TIA, transient ischemic attack; CV, cardiovascular.

*C. pneumoniae* DNA within their peripheral blood, and (2) the percentage of patients with direct evidence of *C. pneumoniae* bacteria within the blood is substantially lower than the percentage who are seropositive for IgG or IgA antibodies targeted against *C. pneumoniae* antigens. Whether these major differences are related to the sensitivity of the test or to a difference in the degree of chronic infection compared to a history of infection remains to be seen. Other laboratories have also documented the ability to detect *C. pneumoniae* bacterial DNA within the blood of atherosclerotic patients (12–25). The prevalence of peripheral blood mononuclear cell (PBMC) DNA detection within patients ranges from 12.5 to 60%. However, it is generally significantly less than the prevalence of IgG or IgA seropositivity. To date, no single study has been sufficiently large to determine accurately the strength of the association between detection of chlamydial DNA and atherosclerosis. A meta-analysis of 18 PCR studies has estimated the association in patients with CVD compared with control subjects without disease (13). In the nine studies with control subjects, the prevalence of circulating *C. pneumoniae* DNA was 252 of 1763 (14.3%) for patients with CVD and 74 of 874 (8.5%) for control subjects, for a pooled odds ratio (OR) of 2.03 (95% confidence interval [CI]: 1.34, 3.08;  $p < 0.001$ ). Higher prevalence (>40%) was found in patients with cardiac, vascular, chronic respiratory, or renal disease, and in blood donors.

As for serology, standardization of PCR techniques for the detection of chlamydial DNA in the blood has not yet occurred. In the meta-analysis just described (13), substantial differences among studies were identified in methods of sampling, extraction, and PCR targets. Likewise, in the consensus report from the CDC (9), only 4 of 18 PCR assays described in published reports met the expert panel's proposed validation criteria.

### ***Pathological Evidence***

In 1992, Shor et al. (26) described electron microscopic examination of preexisting coronary atherosclerotic plaque taken at autopsy from seven patients. Particles within cells were consistent in morphology with *C. pneumoniae*, and the same samples, when subjected to an immunocytochemical test specific for that organism, were confirmed to be *C. pneumoniae* in five of the seven specimens tested. Our laboratory confirmed this initial finding in a group of 90 patients with symptomatic atherosclerosis who underwent directional coronary atherectomy with subsequent percutaneous removal of atherosclerotic plaque (27). By direct immunofluorescence testing, it was found that 79% of the atherectomy specimens had evidence of the presence of *Chlamydia* species. By comparison, no such evidence was found in control subjects or a group of cardiac transplant patients who developed CAD through chronic transplant rejection rather than through typical atherogenesis.

Other studies have also confirmed both the presence and the viability of *C. pneumoniae* within the atherosclerotic plaque of coronary arteries as well as within all other major arterial beds in which atherosclerosis develops, in both young and old patients (Table 2). The organism has been detected by electron microscopy, immunocytochemistry, direct immunofluorescence, PCR detection of nucleic acid, and direct culture of the organism (28,29).

### ***Animal Studies of C. pneumoniae and Atherosclerosis***

Fong et al. (30) conducted the first animal study designed to determine a causative relationship between vascular infection with *C. pneumoniae* and atherosclerosis. Eleven rabbits fed a normal diet were infected with *C. pneumoniae* intranasally, and within 4 wk, two

Table 2  
Pathological Evidence of an Association Between Atherosclerosis and *C. pneumoniae*<sup>a</sup>

Author (Reference) and date	Methods used	Samples studied and no.	Incidence (%)
Shor et al. (26), 1992	ICC, PCR	Autopsy coronary artery (7)	71
Kuo et al. (142), 1993	ICC, PCR, EM	Autopsy coronary artery (36)	56
Davidson et al. (143), 1998	ICC, PCR	Autopsy coronary artery (60)	37
Kuo et al. (144), 1997	ICC, PCR	Femoral artery (23)	48
Jackson et al. (145), 1997	ICC, PCR, EM	Carotid artery (16)	69
Jackson et al. (146), 1997	ICC, PCR	Coronary artery (38)	34
Grayston et al. (147), 1995	ICC, PCR	Carotid artery (56)	57
Campbell et al. (148), 1995	ICC, PCR	Coronary atherectomy (38)	53
Kuo et al. (149), 1995	ICC, PCR	Autopsy coronary artery (18)	39
Kuo et al. (150), 1993	ICC	Aorta (21)	33
Shor et al. (151), 1998	ICC, PCR, EM	Autopsy various arteries (24)	71
Maass et al. (152), 1998	PCR	Various arterial plaques (238)	21
Maas et al. (153), 1998	PCR	Coronary artery (158)	22
Wong et al. (154), 1999	PCR	SVG, IMAG (49)	38
Ouchi et al. (155), 1998	ICC, PCR	Coronary, iliac arteries (39)	64
Paterson et al. (156), 1998	PCR	Coronary, carotid arteries (49)	0
Lindholt et al. (157), 1998	PCR	Abdominal aortic aneurysm (20)	0
Juvonen et al. (158), 1997	ICC, PCR	Abdominal aortic aneurysm (12)	100
Blasi et al. (159), 1996	PCR	Abdominal aortic aneurysm (51)	51
Weiss et al. (160), 1996	PCR, EM	Coronary atherectomy (58)	2
Muhlestein et al. (27), 1996	DIF	Coronary atherectomy (90)	79
Yamashita et al. (161), 1998	ICC	Carotid artery (20)	55
Wong et al. (162), 1999	PCR	SVG, IMAG (49)	38
Virok et al. (163), 2001	PCR	MCA (15)	33

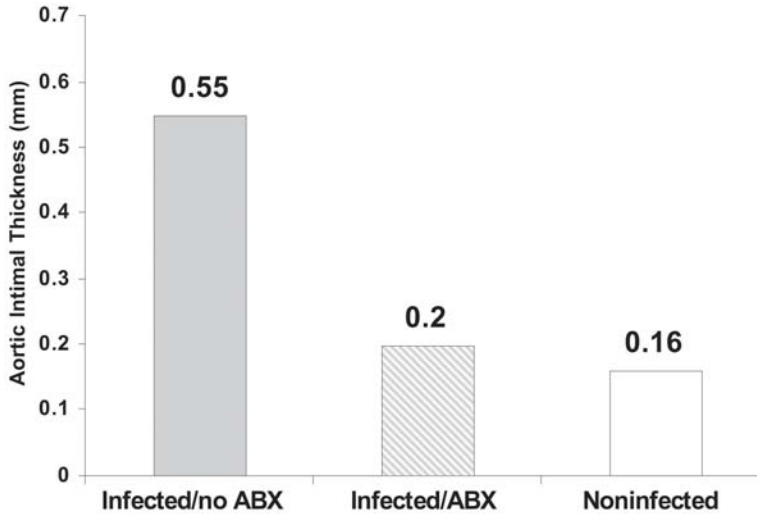
<sup>a</sup>ICC, immunocytochemistry; PCR, polymerase chain reaction; EM, electron microscopy; DIF, direct immunofluorescence; SVG, saphenous vein graft; IMAG, internal mammary arterial graft.

of the rabbits had evidence of new or intermediate atherosclerotic lesions of the aorta. These results were also reproduced by Saikku and associates in Finland, but in each study the lesions were relatively minor (31). In a study by my group (32), rabbits fed 0.25% cholesterol diets were administered three separate intranasal inoculations of *C. pneumoniae* vs saline. The infected rabbits were then randomized to receive azithromycin, an antibiotic that is effective against *C. pneumoniae*, or placebo. This study demonstrated a significant acceleration of the development of atherosclerosis in the aortas of the infected/untreated rabbits tested compared with the other two groups (Fig. 3).

A variety of other animal models have also been tested. Mouse models using the ApoE-deficient mouse (33), the low-density lipoprotein receptor-deficient mouse (34), as well as the C57BL/6J mouse (35) models have been successfully infected with *C. pneumoniae* through intranasal routes followed by successful detection of the organism within the arterial walls and the resultant acceleration of the development of atherosclerosis within these vessels. Likewise, some animal studies have documented worsening of endothelial function after repeated infection with *C. pneumoniae* (36).

Nevertheless, not all animal studies have been resoundingly positive, and it appears that some degree of hyperlipidemia is nearly always required before true atherosclerotic lesions can be produced (37,38). Additionally, no animal model of atherosclerosis exactly





**Fig. 3.** Graph of mean intimal thickness of aortic sections from animals in the infected/untreated group, control (uninfected/untreated) group, and infected/treated group. ABX, antibiotics.

mimics that of the human disease. Therefore, although generally supportive of the hypothesis, these studies, by themselves, do not yet prove that intravascular infection with *C. pneumoniae* plays a causative role in human CVD.

### Therapeutic Trials

Based on the hypothesis that if *C. pneumoniae* contributes to the development of atherosclerosis treatment with antichlamydial agents will help in secondary prevention, a variety of randomized clinical trials have been performed. In a small study from London (39), 60 male patients who were stable post-MI and seropositive to *C. pneumoniae* were randomized to receive azithromycin (500 mg/d for 3 d [ $n = 28$ ] or 500 mg/d for 6 d [ $n = 12$ ]) or placebo and followed for 18 mo for the end points of death, MI, or the need for coronary revascularization. Although the study population was small, there was a statistically significant reduction in the number of events in the group receiving antibiotic treatment (25 vs 8%;  $p = 0.03$ ).

In a study from Argentina (40), the effect of roxithromycin was assessed in a double-blind, randomized, prospective, multicenter, parallel-group, placebo-controlled pilot study of 202 patients with unstable angina or non-Q-wave MI. No serological test was required for inclusion in this study. Patients were randomly assigned either 150 mg of roxithromycin orally twice a day ( $n = 102$ ) or placebo orally twice a day ( $n = 100$ ). The treatment was for 30 d. Patients were followed for 6 mo with primary clinical end points of cardiac ischemic death, MI, and severe recurrent ischemia assessed at d 31. A statistically significant reduction in the primary composite triple end point rates was observed in the roxithromycin group:  $p = 0.032$ . The rates of severe recurrent ischemia, MI, and ischemic death were 5.4, 2.2, and 2.2% in the placebo group and 1.1, 0, and 0% in the roxithromycin group, respectively. At 6 mo, there remained a trend toward benefit in the treated group, but the difference had narrowed such that statistical significance was no longer present (41).

In a third study (42), 302 patients with known CAD who were seropositive to *C. pneumoniae* were randomized to receive either 500 mg/d of azithromycin for 3 d followed by

500 mg/wk for 3 mo or placebo. By 6 mo, (3 mo after discontinuation of antibiotic), a statistically significant reduction in levels of C-reactive protein (CRP) and interleukin-6 was noted in the treatment group. However, after 2 yr of clinical follow-up, there was no significant difference in the cardiovascular end points between the two groups (hazard ratio [HR] for azithromycin: 0.89; 95% CI: 0.51–1.61;  $p = 0.74$ ), although a trend toward benefit in the azithromycin arm was noted during the second year of the study (HR: 0.59; 95% CI: 0.23–1.50;  $p = 0.26$ ) (43). Antibiotic therapy caused no change in serological markers.

The ISAR-3 Trial tested the hypothesis that antibiotic therapy may be helpful in the prevention of restenosis after coronary stent deployment (44). A total of 1010 patients undergoing percutaneous coronary intervention were randomized to receive 300 mg of roxithromycin daily for 4 wk vs placebo and followed for 6 mo. No significant differences in 6-mo angiographic restenosis rate, target vessel revascularization, or major cardiac events at 30 d in the overall group were noted. There was, however, a differential effect dependent on *C. pneumoniae* titers. In patients with high titers, roxithromycin reduced the rate of restenosis.

In the last of a series of smaller trials, the randomized clinical trial entitled STAMINA (45) was reported in which 325 patients presenting with acute coronary syndrome (ACS) were randomized to one of three treatment regimens, each lasting 1 wk: (1) 500 mg/d of azithromycin, 20 mg of omeprazole twice daily, and 400 mg of metronidazole twice daily (designed to be an antichlamydial regimen); (2) 500 mg of amoxicillin twice daily, 20 mg of omeprazole twice daily, and 400 mg of metronidazole twice daily (designed to be an anti-*Helicobacter* regimen); or (3) placebo. All patients received standard treatment for coronary heart disease (CHD). After 12 mo of follow-up, there was no significant difference in the frequency or timing of major adverse cardiac events (MACE) for either the azithromycin- or the amoxicillin-treated groups compared to placebo. However, when combined, subjects receiving either one or the other active antibiotic treatment regimen had a 40% reduction in MACE compared to placebo ( $p = 0.034$ ). The full benefit was observed by 12 wk and persisted up to 1 yr. No differences in inflammatory markers were noted. Seropositivity to *C. pneumoniae* or *H. pylori* also had no effect. The investigators made the point that this study could not distinguish whether the benefits were related to the antimicrobial or anti-inflammatory properties of the antibiotics used. Larger clinical trials were recommended.

The first large trial, Weekly Intervention with Zithromax for Atherosclerosis and Its Related Disorders (WIZARD) (46,47), was completed in early 2002. A total of 7724 stable patients with a history of MI and documented presence of seropositivity to *C. pneumoniae* were randomized to receive either placebo or 3 mo of treatment with azithromycin (600 mg/wk). The primary clinical end points were death, MI, admission for unstable angina, and the need for repeat revascularization at the end of the study. Overall, short-term (3 mo) azithromycin therapy was safe and well tolerated. However, it resulted in only a 7% overall nonsignificant reduction in the incidence of recurrent CVD in this population of stable *C. pneumoniae*-positive, post-MI patients. No evidence of a treatment effect by baseline *C. pneumoniae* titer was observed. Post-hoc analyses did suggest a possible early treatment benefit (33% reduction in death/MI at 6 mo [ $p = 0.03$ ]) that was not sustained over the observation period. This raised the question, could prolonged antimicrobial therapy produce a more sustained clinical benefit?

In the Azithromycin in Acute Coronary Syndrome (AZACS) study (48), patients ( $n = 1439$ ) with ACS (unstable angina or MI) were randomized in a double-blind, placebo-

controlled fashion to either 500 mg/d of azithromycin followed by 250 mg/d for 4 d or matching placebo. The primary end point was death from any cause, nonfatal MI, and recurrent ischemia at 6 mo. Secondary end points included worsening of ischemia and new congestive heart failure requiring hospitalization. Short-term (4 d) treatment with azithromycin did not have any effect on the recurrence of the primary or secondary end points during a 6-mo follow-up period. Likewise, there was no difference between patients who tested positive for the presence of *C. pneumoniae* antibodies and those who did not. Interestingly, similarly to the WIZARD study, there was a trend toward early benefit from antibiotic therapy during the first 2 mo after antibiotic therapy, but this was not sustained over the entire 6 mo of the study.

The Azithromycin and Coronary Events Study (ACES) was a National Institutes of Health-sponsored, randomized, double-blind, placebo-controlled trial of azithromycin among 4012 adults with stable CHD (49). ACES did not require seropositivity to *C. pneumoniae* although serology was assessed. Participants were randomized to 600 mg of azithromycin orally once a week for 1 yr or placebo with follow-up for a mean of 4 yr. The primary end point was a composite of CHD death, nonfatal MI, hospitalization for unstable angina, and coronary revascularization. The primary end point occurred in 22.4% of patients assigned to placebo and 22.3% of patients assigned to azithromycin, representing a reduction in relative risk (RR) of <1% (95% CI: 13 to -13%), a clearly neutral, nonsignificant result (Thomas Grayston, European Society of Cardiology, Munich, August 30, 2004). Further, unlike WIZARD, ACES observed no trends to early benefit during active antibiotic therapy. Individual components of the composite end point also were not reduced by antibiotic compared to placebo, i.e., 3.2 vs 3.7% for CHD death and 6.8 vs 6.5% for MI. Similarly, no differences emerged for revascularization, unstable angina, stroke, or all-cause mortality. Moreover, there was no benefit in subgroups defined by negligible, low, or high antichlamydial IgG antibody titer. Antibiotic therapy was associated with a modest increase in gastrointestinal (GI) symptoms (nausea, abdominal pain, diarrhea). The investigators concluded that azithromycin, even when given chronically for 1 yr, is ineffective for secondary cardiovascular prevention.

The Pravastatin or Atorvastatin Evaluation and Infection Therapy (PROVE-IT) study thus addressed an important question regarding the role of therapy targeting infection in the pathogenesis of ACS. PROVE-IT was a double-blind, randomized, 2 ↔ 2 factorial, multicenter secondary prevention trial in 4162 patients with ACS. In the antibiotic arm of this trial, patients were randomized to 400 mg/d of gatifloxacin for 10 d repeated monthly, or placebo. Follow-up lasted 18–36 mo (mean: 24 mo). The primary end point was a composite of death from any cause, MI, unstable angina requiring hospitalization, revascularization performed >30 days after randomization, and stroke. The study concluded after >1000 events had occurred, providing 94% power to exclude a 19% treatment effect. Drug exposure at the end of the study averaged 1.6 yr. Event rates were 25.1% in the placebo group and 23.7% in the gatifloxacin group, representing a 5% reduction in HR (95% CI: 16 to -8%), an insignificant difference (Christopher Cannon, European Society of Cardiology, Munich, August 30, 2004). No benefits were observed in major patient subgroups, including those stratified by high-sensitivity CRP (hsCRP) or by *C. pneumoniae* antibody positivity. Antibiotic therapy decreased the incidence of upper respiratory infection, but it caused more GI side effects (nausea, vomiting, diarrhea) and did not affect hsCRP levels. In a substudy, PCR of PBMCs was positive for *C. pneumoniae* in only 3.5%. The investigators concluded that when used in conjunction with contemporary preventive strategies,

including aggressive lipid lowering, gatifloxacin is ineffective for secondary cardiovascular prevention.

Although these large randomized trials were negative for the primary outcomes, several concerns still exist regarding whether their results shed more light on the question of causality between *C. pneumoniae* and atherosclerosis. First, did the antibiotics effectively eradicate the organism? Both macrolides and quinolones are generally felt to be bacteriostatic rather than bactericidal. Chronic intracellular organisms such as *C. pneumoniae* may be able to survive even large doses of such therapeutic agents. *C. pneumoniae* may be able to survive and even thrive within monocytes treated with high-dose, but short duration, azithromycin (50). It may therefore be necessary to use multidrug therapy in a manner similar to that required to eradicate tuberculosis. Second, can one ascertain eradication of an organism in a specific patient? Serological studies have not correlated well with the presence of intra-plaque organisms. Evaluation of PBMCs is not standardized, and throat cultures also have not been found to be useful. Finally, the possibility still exists that *C. pneumoniae* is merely an innocent bystander and does not really play a pathogenic role in the development or progression of atherosclerosis.

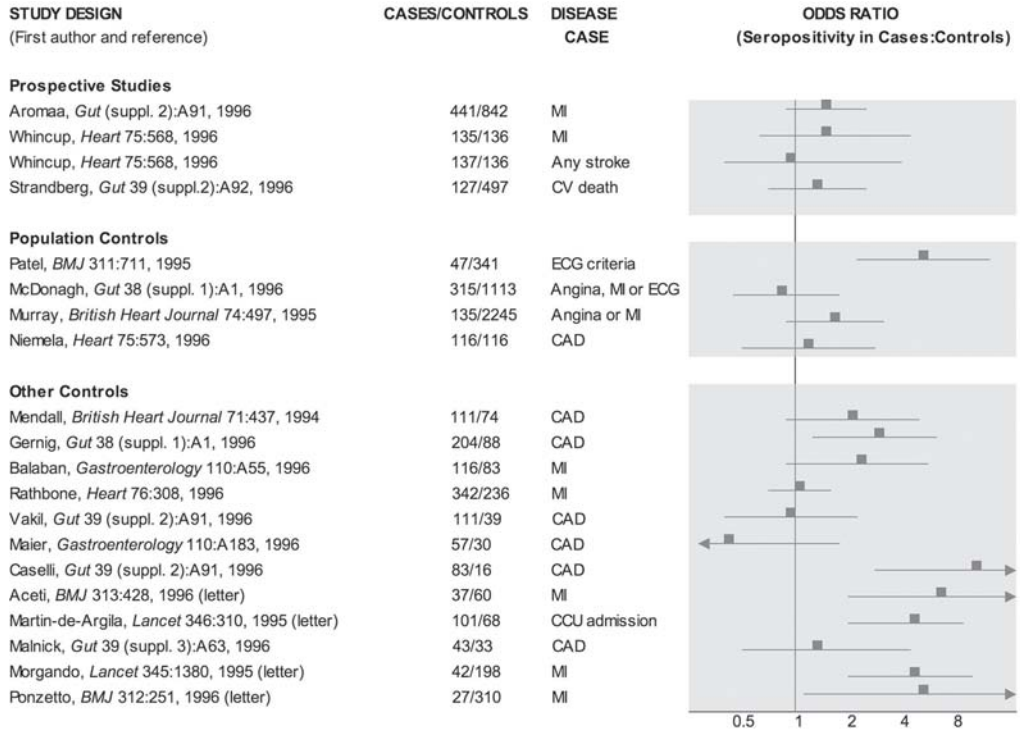
### Summary

*C. pneumoniae* has been found to be associated with coronary atherosclerosis in a variety of ways. First, it has been found to be associated by seroepidemiological studies. Second, it has been found to be present in a significant majority of atherosclerotic lesions. Third, intranasal inoculation of *C. pneumoniae* has been found to both initiate and accelerate the development of atherosclerosis in animal models. Fourth, several small clinical trials have demonstrated promise regarding the ability of antibiotic treatment directed against *C. pneumoniae* to have a positive effect in the secondary prevention of known coronary atherosclerosis, but this benefit has not been confirmed in large multicenter trials. At the present time, the available evidence does not support treating patients with CAD with antibiotic therapy as a secondary prevention measure.

### HELICOBACTER PYLORI

*H. pylori* is a Gram-negative, spiral, flagulated bacillus that naturally infects humans and monkeys (51). It is not invasive, either living in the mucus that overlies gastric mucosa or adhering to the mucosa itself. The prevalence of *H. pylori* infection is about 30% in the United States and other developed countries, and about 80% in most developing countries (52). In the United States, about 50% of people will have evidence of prior *H. pylori* infection by age 60. Most studies show that spontaneous acquisition or loss of infection in adulthood is uncommon, so most infections are thought to be acquired in childhood (53).

Over the past decade or so *H. pylori* has been shown to play a causative role in gastric inflammation and peptic ulcer disease. Its role has been established because the presence of infection is a risk factor for the development of ulcers; ulcers do not develop in the absence of infection, except when other known etiological factors exist, such as the use of nonsteroidal anti-inflammatory drugs; care of the infection results in a dramatic drop in the rate of ulcer relapse, from 80 to 15% in the first year, with even lower rates thereafter; and experimental infection of gerbils and mice causes gastroduodenal injury. Gastric infection with *H. pylori* is also found to be associated with the development of stomach cancer.



**Fig. 4.** ORs of risk of CHD based on seropositivity to *H. pylori* among 20 epidemiological studies (see text for further explanation). (Adapted from ref. 55.) ECG, electrocardiogram; CCU, coronary care unit.

### Serological and Pathological Data

Up to the present, evidence for an association between *H. pylori* and atherosclerosis is mainly serological, although some pathological evidence also exists. The first suggestion of an association came in 1994, when Mendall et al. (54) reported that 59% of 111 patients with documented CAD were seropositive for *H. pylori* compared with 39% of age- and sex-matched control subjects.

At least 19 epidemiological studies have evaluated the possibility of an association between seropositivity to *H. pylori* and CAD (55). In some of these studies, a trend toward a positive association with *H. pylori* seropositivity was evident, but overall the association appears to be small. Danesh and Peto (56) conducted a meta-analysis of a significant number of these studies, and the results are shown in Fig. 4.

In many of these epidemiological studies, there was little adjustment for possible confounding variables. Studies that did try to reduce the effects of selection bias by adjusting for potential confounders and sampling controls from approximately the same population as their cases tended to report weaker associations. At present it appears that any independent association between seropositivity for *H. pylori* and CAD would be small.

Two small studies have shown that *H. pylori*-seropositive people have high plasma concentrations or counts of markers of inflammation including fibrinogen, CRP, and leukocytes, but these associations are modest (57). It has also been suggested that autoimmune reactions against endogenous HSP60 and other endothelial antigens could be involved

in atherogenesis (58). *H. pylori* contains a protein similar to HSP60 and the possibility of an association between *H. pylori* infection and an immune response to HSP60 is being investigated. Additionally, a specific strain of *H. pylori* that bears the cytotoxin-associated gene-A (*CagA*) and appears to be more virulent than usual has been found to be significantly more associated with coronary atherosclerosis than other strains studied (59,60). Although not extensively tested, *H. pylori* has also been detected in the walls of atherosclerotic arteries (61).

### Summary

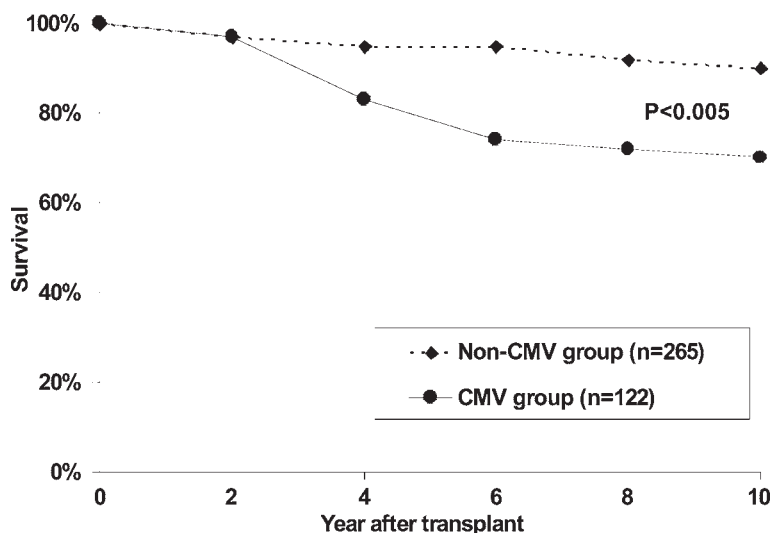
*H. pylori* has been found to be the primary etiological agent of peptic ulcer disease. Some seroepidemiological associations between *H. pylori* infection and CAD have been found. However, to this point, the association with CAD is modest at most, with an average OR <1.8. One specific, more aggressive strain of *H. pylori* has been reported, although not consistently, to be more commonly associated with atherosclerosis than other strains. Further information and study will be required before an etiological relationship between *H. pylori* and atherosclerosis may be assigned.

### MYCOPLASMA PNEUMONIAE

In 1898, Nocard and Roux (62) identified *Mycoplasma* as a cause of respiratory tract illness when they isolated a slowly growing organism from contagious bovine pleuropneumonia specimens. Later investigators referred to similar clinical isolates as pleuropneumonia-like organisms. Some investigators thought these organisms should be considered viruses because the organisms were smaller than any known bacteria. The fact that the organisms could replicate extracellularly led to the correct conclusion that they were somewhat similar to bacterial L forms. *Mycoplasma* species belong to the class Mollicutes (soft skin), which comprises the smallest free-living microorganisms. *M. pneumoniae* is the most widely recognized pathogen of the 12 species of *Mycoplasma* found in humans (63). A receptor on the cell membrane allows the organism to attach to diverse cell types, such as respiratory tract epithelia and red blood cells. In high concentrations the organisms inhibit the ciliary action of the respiratory epithelia and cause cell necrosis. The resulting morbidity is the combined direct effect of cytotoxins produced by the organisms and the indirect effect of inflammatory responses to the presence of the organisms. Although antimicrobial agents influence the course of illness, they do not eliminate the nasopharyngeal carriage stage and, therefore, many persons are susceptible to a chronic form of the illness (64).

Horne et al. (65) first described a serological association between *M. pneumoniae* infection and atherosclerosis in a case-control study of 498 patients undergoing coronary arteriography, of which 307 patients had diseased and 191 had healthy coronary arteries. The prevalence of CAD was significantly greater among patients with elevated IgA antibody titers to *M. pneumoniae* (OR: 2.2;  $p = 0.005$ ) although not among those with elevated IgG titers. This association was further strengthened by an analysis of 1517 patients with angiographically defined CAD who were followed clinically for 2.4 yr (66). The incidence of death or MI was significantly higher among patients with elevated IgA antibody titers to *M. pneumoniae* (26 vs 16%; adjusted  $p = 0.04$ ; HR: 1.5; 95% CI: 1.1, 2.1). IgG titers to *M. pneumoniae* did not have any predictive value.

Although the evidence is not nearly so convincing as with *C. pneumoniae*, some studies have also reported the presence of *M. pneumoniae* organisms within atherosclerotic plaque (67,68).



**Fig. 5.** Graph of survival curves of patients undergoing cardiac transplant who are seropositive vs seronegative to CMV. (Adapted from ref. 164.)

## CYTOMEGALOVIRUS

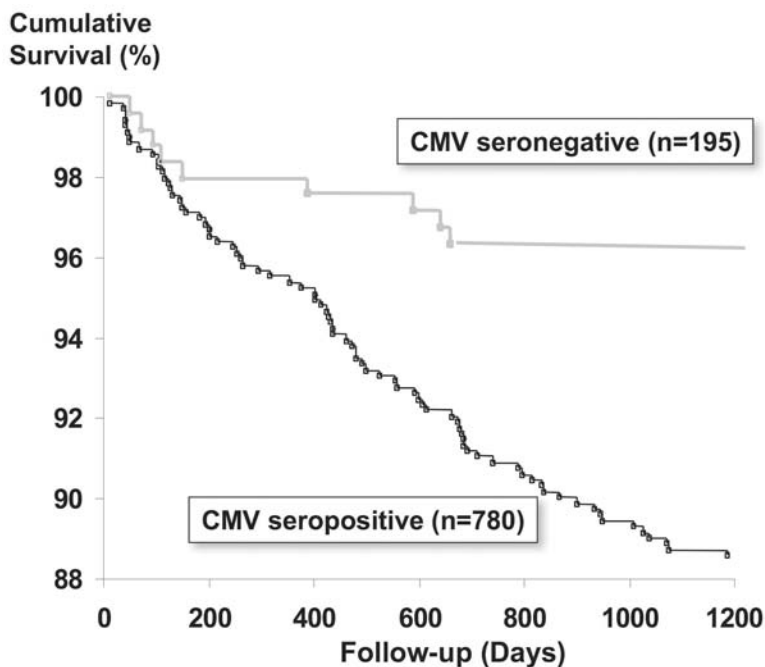
The hypothesis that viruses might be associated with the development and progression of atherosclerosis has been around for years, but despite substantial effort, a strong association has yet to be confirmed. The most likely candidate is cytomegalovirus (CMV), a member of the herpes virus family.

Researchers discovered in the midtwentieth century that a herpes virus was the cause of a malignant disorder in chickens called Marek lymphomatosis (69). Chickens with this disease also developed significant atherosclerosis, raising the question, could other herpes viruses capable of infecting humans also induce atherosclerosis (70)?

Adam et al. (71) carried out two studies to test this hypothesis. First, seropositivity to CMV was found to be significantly higher in patients with known coronary atherosclerosis, as evidenced by the greater need for coronary bypass surgery than in a control group with 5 yr of documentation of the absence of symptomatic atherosclerosis. Second, atherosclerotic tissue samples yielded CMV in 90% of cases, but the virus was also present nearly as frequently in healthy vessels (72).

Although these two studies indicated an association between atherosclerosis and CMV infection, not all studies have supported the same conclusion. In a case-control study of patients undergoing coronary arteriography at my institution (8), an overall high incidence of seropositivity to CMV (77%) was discovered, but no difference in the seropositivity between patients with severe coronary disease and those with healthy coronary arteries was detected. Thus, seroepidemiological case-control studies may be complicated by the high incidence of seropositivity found in the control arm.

More conclusive evidence for an association between CMV and arteriopathy was found in patients undergoing cardiac transplantation. Heart transplant recipients who were seropositive for CMV experienced an increased incidence of graft rejection as well as accelerated arteriosclerosis in the graft (73). Most important, CMV-seropositive patients had a significantly higher mortality over 10 yr of follow-up (Fig. 5).



**Fig. 6.** Graph of survival curves of patients with angiographically documented severe CAD who are seropositive (black line) vs seronegative (gray line) to CMV.

Similar findings regarding mortality after diagnosis of atherosclerotic CAD were found in a study performed at my institution on patients with typical atherosclerotic heart disease (74). In this study, not only was CRP predictive of a higher incidence of mortality during long-term follow-up, but seropositivity to CMV was also found to be independently predictive of mortality by 3 yr (Fig. 6). This effect was also found to be independent of other known risk factors including CRP. From the Registry of the Intermountain Heart Collaborative Study, Horne et al. (75) provided further evidence regarding the association between CMV seropositivity and future outcome in patients with known CAD. CMV IgG serology was measured as an immune status ratio (ISR) value by ELISA in a cohort of 2797 patients with CAD who were followed for up to 7.9 yr (mean:  $3.3 \pm 2.0$  yr) to determine the incidence of all-cause mortality. A significant linear association with mortality was found for the continuous ISR values (HR: 1.09/ISR unit;  $p < 0.001$ ). Recursive partitioning confirmed the manufacturer's threshold for seropositivity as an appropriate decision point for risk of CHD (seronegative: death = 10%; seropositive: death = 19%; fully adjusted Cox:  $p = 0.016$ , HR: 1.3; 95% CI: 1.1–1.7). However, among seropositive patients it also revealed a second threshold (ISR = 3.76) above which the excess risk of mortality declined, 22% for ISR = 1.1–3.76 ( $n = 964$ ;  $p = 0.038$  vs seronegative; HR: 1.4; 95% CI: 1.02–1.8) and 16% for ISR > 3.76 ( $n = 1168$ ;  $p = 0.30$  vs seronegative; HR: 1.2; 95% CI: 0.87–1.6). These findings raise questions about the nature and complexity of the host immunological response to CMV exposure and how it relates to determination of risk of CHD. A modest immunological response might be inadequate to clear the virus, whereas a brisk response might be more effective and hence ameliorate risk. Data from the Heart Outcomes Prevention Evaluation study (76) confirmed the independent predictive value



of seropositivity to CMV on secondary outcomes. It is becoming more apparent that exposure to CMV may play some role in the further progression of atherosclerotic heart disease after angiographic diagnosis.

The association between CMV and atherosclerosis is intriguing and may be important. Serological associations have been found in both secondary case-control and cohort studies. A more rapid and progressive atherosclerotic process resulting in high mortality after angiographic documentation of coronary disease in seropositive patients has been found.

### OTHER HERPESVIRUSES

Although CMV has the most information regarding its potential role in the development and progression of coronary atherosclerosis, a variety of other viruses have also been implicated. Herpes simplex virus (HSV) has been associated with atherosclerosis in a variety of ways. In vitro studies of HSV-1 and HSV-2 have demonstrated the presence of similar potentially proatherogenic mechanisms similar to those found with CMV. Specifically, HSV infection leads to lipid accumulation in vascular cells, attraction of leukocytes with subsequent inflammatory damage, and induction of procoagulant changes on endothelium, with increased thrombin generation and platelet adhesion. It also has been shown that HSV causes atherosclerosis in experimental animals. From a clinical standpoint, several investigators have reported the detection of HSV in some, but not all, atherosclerotic lesions. As with a variety of other antibody studies, serological evidence of HSV infections is common, not only in atherosclerotic patients but also in the general population, making epidemiological studies difficult to interpret (77–81).

### HUMAN IMMUNODEFICIENCY VIRUS

Some evidence has also linked human immunodeficiency virus (HIV) with atherosclerosis. Constans et al. (82) showed that, although no clinically relevant atherosclerotic lesions were found, plaques occurred more often in patients with HIV than in control subjects. During postmortem examination of eight HIV-seropositive male patients, major atherosclerosis in coronary arteries was present in the absence of an associated cardiovascular risk factor (83). Investigators have postulated that viral infection, either HIV or coexisting herpesviruses, may play a role in the development of the coronary lesions. However, because of the complexity of the disease, it is difficult to establish whether HIV itself, or an opportunistic pathogen, or both are causally related to the process of atherosclerosis.

### INFLUENZA VIRUS

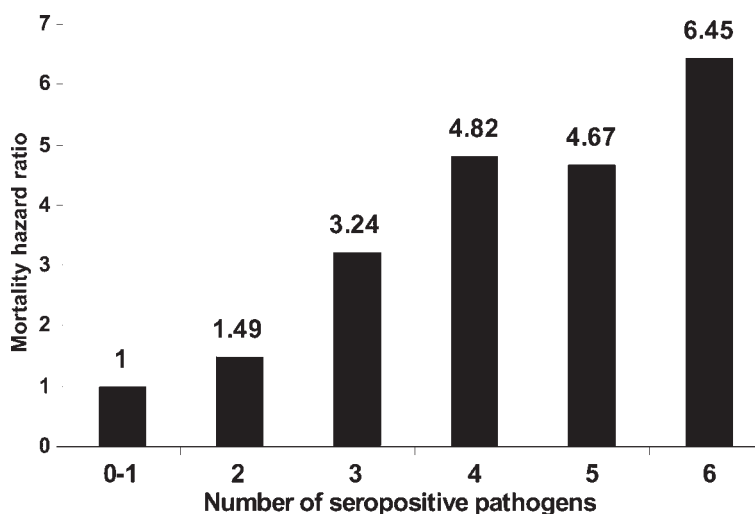
Although most studies examining an association between infection and atherosclerosis have been conducted to elucidate the association of infection with the development of atherosclerosis, a few studies have targeted the triggering of ACSs by infections. One prospective study (84) and several retrospective studies have suggested that acute respiratory infection might trigger MI (85–87). A possible relationship between influenza and MI was first suggested after epidemics of influenza struck Europe and the United States in the early 1900s. In those epidemics, about half of the excess mortality was attributed to causes other than influenza, including heart disease (88). Recent animal studies have also implicated the influenza virus in destabilization of atherosclerotic plaque (89).

Perhaps the most exciting discovery regarding the influenza virus and atherosclerosis is the potential beneficial effect of influenza vaccination on the clinical outcome of patients

with known CVD. Naghavi et al. (90) reported the results of a case–control study of 218 cardiovascular patients seen during the influenza season. Patients who experienced new MI were included in the case group, and those who did not experience new MI or unstable angina were assigned to the control group. In this study vaccination against influenza was negatively associated with the development of new MI during the same influenza season (OR: 0.33; 95% CI: 0.13–0.82;  $p = 0.017$ ). Likewise, fewer patients with new stroke were vaccinated during the last vaccination campaign than control subjects (46.7 vs 59.4%;  $p = 0.036$ ) with a similar pattern during the prior 5 yr (41.1 vs 56.1%;  $p = 0.017$ ) (91). After adjustment for age, traditional risk factors, and recent use of antibiotics, the risk of stroke was reduced in the subjects vaccinated during the year of the study and in those vaccinated during the previous 5 yr, OR of 0.50 (95% CI: 0.26–0.94;  $p = 0.033$ ) and 0.42 (95% CI: 0.21–0.81;  $p = 0.009$ ), respectively. It was concluded that influenza vaccination may protect against cerebral infarction by reducing infections. Not all retrospective studies, however, have shown a correlation between influenza vaccination and coronary events. In a population-based inception cohort study of 1378 Group Health Cooperative enrollees who survived a first MI in 1992 through 1996, the risk of recurrent coronary events was not associated with prior influenza vaccination (adjusted HR: 1.18; 95% CI: 0.79, 1.75) (92). One randomized clinical trial of influenza vaccination for the prevention of recurrent coronary events has been reported. Gurfinkel et al. (93) randomized 200 patients with MI and 101 patients who underwent percutaneous coronary revascularization in a single-blind manner to either a unique im influenza vaccination or a control group. Through 6 mo of follow-up, cardiovascular death occurred in 2% of the patients in the vaccine group compared with 8% in the control group (RR: 0.25; 95% CI: 0.07–0.86). A composite of death, reinfarction, or rehospitalization for ischemia occurred in 11% of the patients in the vaccine group compared with 23% in the control subjects ( $p = 0.009$ ). It was concluded that influenza vaccination may reduce the risk of death and ischemic events in patients experiencing infarction and those recovering from angioplasty during flu season. Therefore, it is my opinion that, although larger studies are required before routine influenza vaccination can be recommended to all cardiovascular patients, the present evidence suggests that, at least in cardiovascular patients who already meet standard indications for vaccination, in addition to the expected anti-infective benefits, cardiovascular protective effects might also be experienced by those receiving the influenza vaccine.

### TOTAL PATHOGEN BURDEN AS AN AGGREGATE SEROLOGICAL RISK FACTOR

Given the modest and variable predictive value of most tested pathogen candidates, Epstein et al. (94) proposed the sum of relevant infectious exposures, expressed as a total pathogen burden, as an improved prognostic seromarker of risk. Exposure to a panel of five pathogens was tested and found to improve prediction of angiographic CAD in a cross-sectional study (95) and incident events among patients with CAD in a separate prospective study (Fig. 7) (96). Subsequently, European investigators found an association between the number of exposures to a panel of eight pathogens and cardiovascular mortality in patients with CAD in the Autogene Study (97). In another study of 572 patients, IgG or IgA antibodies to HSV-1 and HSV-2, CMV, Epstein-Barr virus, *Hemophilus influenzae*, *C. pneumoniae*, *M. pneumoniae*, and *H. pylori* were measured (98). The extent of atherosclerosis was determined by coronary angiography, carotid duplex sonography, and evaluation of the ankle-arm index. Pathogen burden, divided into zero to three, four to five, and six



**Fig. 7.** Graph of adjusted death/MI HRs based on baseline IgG seropositivity to number of pathogens (“pathogen burden”), including CMV, hepatitis A virus, HSV-1, HSV-2, *C. pneumoniae*, and *H. pylori* among 890 patients with significant CAD on angiography who were followed for 3 yr(96).

to eight agents for which seropositivity was evident, was significantly associated with advanced atherosclerosis, with an OR (95% CI) of 1.8 (1.2–2.6) for four to five ( $p < 0.01$ ) and 2.5 (1.2–5.1) for six to eight seropositivities ( $p < 0.02$ ) (adjusted). After a mean follow-up of 3.2 yr, the cardiovascular mortality rate was 7.0% in patients with advanced atherosclerosis and seropositive for zero to three pathogens compared with 20.0% in those seropositive for six to eight pathogens. Although the full implications of such analyses of multiple infectious seropositivity remain to be discovered, these initial findings do provide further evidence that a variety of infectious processes may play a role in the development and progression of atherosclerosis (99).

### CLINICAL USE OF INFECTIOUS MARKERS FOR RISK STRATIFICATION: NOT YET READY FOR PRIME TIME

Although a significant number of infectious markers are available and are linked by epidemiological evidence to atherosclerotic CVD, the evidence does not yet rise to the level required to justify routine use during clinical risk stratification of individual patients. Limitations of the available body of information arise from several perspectives.

First, the infection and atherosclerosis hypothesis remains just that, a hypothesis. A direct cause-and-effect relationship has not yet been proven in humans for any of the infectious agents of interest. Additionally, especially for the serological markers, the strength of the data describing a significant association remains controversial and is in some instances quite weak. Greater understanding of the underlying processes relating various infections to atherosclerosis must be obtained before any individual test result can be appropriately interpreted.

Second, in most instances the observed associations between various markers of infection and atherosclerosis have not yet been determined to be fully independent. As in the case of *H. pylori*, in which more complete adjustment for other known risk factors and markers of atherosclerosis resulted in a near elimination of the association, further study of other markers may demonstrate lack of independence in them as well.

Third, many of the proposed markers are not standardized or validated across multiple laboratories. In many instances, the assays used in various studies were developed by the individual investigators and are not even available commercially. Furthermore, individual normal ranges of values for the various markers of interest have not been established or validated. Whether these ranges differ based on gender, age, and so on also has not been determined. Thus, lack of standardization, lack of validation, and lack of general availability make a general recommendation of the use any of the available infectious markers for cardiovascular risk stratification somewhat premature.

Fourth, at the present limited level of understanding regarding the associations between infection and atherosclerosis, there remains no definite therapeutic strategy that might be recommended based on the results of any infectious-specific marker. For instance, not enough information is presently available to justify initiation of antibiotic therapy. Likewise, not enough information is available to recommend any changes in standard primary or secondary prevention therapies that would otherwise be implemented. Even though certain infectious markers, such as seropositivity to CMV or a high pathogen burden score, as described earlier, may increase the cardiovascular risk of an individual, this information does not lead presently to a modification in therapy. Therefore, justification for its routine use does not yet exist.

## CONCLUSION

Chronic infection has been found to be significantly associated with the development of atherosclerosis and the clinical complications of unstable angina, MI, and stroke. However, failure to confirm initial reports of serological associations also has been common. Specific causative relationships on par with that determined between *H. pylori* and peptic ulcer disease have not yet been established.

The infectious agents with the most evidence to support an etiological role in atherosclerosis include *C. pneumoniae* and CMV. However, evidence is mounting for a variety of other potential agents including other herpesviruses, influenza, other specific bacteria (such as *M. pneumoniae*), and chronic infections with common bacterial agents (e.g., periodontal disease, chronic bronchitis, chronic urinary tract infection) (100). Future studies are expected to elucidate further the pathophysiological relationship between chronic infection and atherosclerosis and to evaluate the potential of a variety of treatment approaches including antibiotics. Until then, however, a general recommendation for the use of any of these infectious markers during routine cardiovascular risk stratification cannot be made.

## REFERENCES

1. Farmer JA, Gotto AM Jr. Dyslipidemia and other risk factors for coronary artery disease. In: Braunwald E, ed. Heart Disease: A Textbook of Cardiovascular Medicine, 5th ed. WB Saunders, Philadelphia, 1997, pp. 1126–1160.
2. Wilson PW, D'Agostino RB, Levy D, Belanger AM, Silbershatz H, Kannel WB. Prediction of coronary heart disease using risk factor categories. *Circulation* 1998;97(18):1837–1847.
3. Grayston IT, Kuo C-C, Campbell LA, Wang S-P. *Chlamydia pneumoniae* sp. Nov. for *Chlamydia* sp strain TWAR. *Int J Syst Bacteriol* 1989;39:88–90.
4. Grayston IT, Campbell LA, Kuo C-C, et al. A new respiratory tract pathogen: *Chlamydia pneumoniae* strain TWAR. *J Infect Dis* 1990;161:618–625.
5. Beatty WL, Morrison RP, Byrne GI. Persistent chlamydiae: from cell culture to a paradigm for chlamydial pathogenesis. *Microbiol Rev* 1994;58(4):686–699.
6. Saikku P, Mattila K, Nieminen MS, et al. Serological evidence of an association of a novel Chlamydia, TWAR, with chronic coronary heart disease and acute myocardial infarction. *Lancet* 1998;2(8618):983–986.

7. Saikku P, Leinonen M, Tenkanen L, et al. Chronic *Chlamydia pneumoniae* infection as a risk factor for coronary heart disease in the Helsinki heart study. *Ann Intern Med* 1992;116:273–278.
8. Anderson JL, Carlquist JF, Muhlestein JB, Horne BD, Elmer SP. Evaluation of C-reactive protein, an inflammatory marker, and infectious serology as risk factors for coronary artery disease and myocardial infarction. *J Am Coll Cardiol* 1998;32(1):35–41.
9. Dowell SF, Peeling RW, Boman J, et al. Standardizing *Chlamydia pneumoniae* assays: recommendations from the Centers for Disease Control and Prevention (USA) and the Laboratory Centre for Disease Control (Canada). *Clin Infect Dis* 2001;33:492–502.
10. Boman J, Soderberg S, Forsberg J, et al. High prevalence of *Chlamydia pneumoniae* DNA in peripheral blood mononuclear cells in patients with cardiovascular disease and in middle-aged blood donors. *J Infect Dis* 1998;178(1):274–277.
11. Muhlestein JB, Carlquist JF, Hammond EH, et al. Detection of *Chlamydia pneumoniae* bacteremia in patients with symptomatic coronary atherosclerosis. *J Invest Med* 1997;45(1):142A.
12. Nyvad O, Larsen NA, Lokkegaard N, Pedersen RS, Solling J, Pedersen EB. *Chlamydia pneumoniae* DNA in peripheral blood mononuclear cells in dialysis patients, renal transplant recipients and healthy controls. *Scand J Clin Lab Invest* 2002;62(7):503–509.
13. Smieja M, Mahony J, Petrich A, Boman J, Chernesky M. Association of circulating *Chlamydia pneumoniae* DNA with cardiovascular disease: a systematic review. *BMC Infect Dis* 2002;2(1):21.
14. Freidank HM, Lux A, Dern P, Meyer-Konig U, Els T. *Chlamydia pneumoniae* DNA in peripheral venous blood samples from patients with carotid artery stenosis. *Eur J Clin Microbiol Infect Dis* 2002;21(1):60–62.
15. Leowattana W, Pokum S, Mahanonda N, Pongvarin N. Rapid detection of *Chlamydia pneumoniae* DNA in peripheral blood mononuclear cells of coronary artery disease patients by real-time fluorescence PCR. *J Med Assoc Thai* 2002;84(Suppl 3):S658–S668.
16. Rassa M, Lauro FM, Cazzavillan S, et al. Detection of *Chlamydia pneumoniae* DNA in peripheral blood mononuclear cells of blood donors in the north-east of Italy. *Med Microbiol Immun* 2001;190(3):139–144.
17. Sessa R, Di Pietro M, Schiavoni G, et al. Prevalence of *Chlamydia pneumoniae* in peripheral blood mononuclear cells in Italian patients with acute ischaemic heart disease. *Atherosclerosis* 2001;159(2):521–525.
18. Smieja M, Chong S, Natarajan M, Petrich A, Rainen L, Mahony JB. Circulating nucleic acids of *Chlamydia pneumoniae* and cytomegalovirus in patients undergoing coronary angiography. *J Clin Microbiol* 2001;39(2):596–600.
19. Iliescu EA, Fiebig MF, Morton AR, Sankar-Mistry P. *Chlamydia pneumoniae* DNA in peripheral blood mononuclear cells in peritoneal dialysis patients. *Peritoneal Dial Int* 2000;20(6):722–726.
20. Kaul R, Uphoff J, Wiedeman J, Yadlapalli S, Wenman WM. Detection of *Chlamydia pneumoniae* DNA in CD3+ lymphocytes from healthy blood donors and patients with coronary artery disease. *Circulation* 2000;102(19):2341–2346.
21. Mahony JB, Chong S, Coombes BK, Smieja M, Petrich A. Analytical sensitivity, reproducibility of results, and clinical performance of five PCR assays for detecting *Chlamydia pneumoniae* DNA in peripheral blood mononuclear cells. *J Clin Microbiol* 2000;38(7):2622–2627.
22. Maass M, Jahn J, Gieffers J, Dalhoff K, Katus HA, Solbach W. Detection of *Chlamydia pneumoniae* within peripheral blood monocytes of patients with unstable angina or myocardial infarction. *J Infect Dis* 2000;181(Suppl 3):S449–S451.
23. Bodetti TJ, Timms P. Detection of *Chlamydia pneumoniae* DNA and antigen in the circulating mononuclear cell fractions of humans and koalas. *Infect Immun* 2000;68(5):2744–2747.
24. Blasi F, Boman J, Esposito G, et al. *Chlamydia pneumoniae* DNA detection in peripheral blood mononuclear cells is predictive of vascular infection. *J Infect Dis* 1999;180(6):2074–2076.
25. Boman J, Soderberg S, Forsberg J, et al. High prevalence of *Chlamydia pneumoniae* DNA in peripheral blood mononuclear cells in patients with cardiovascular disease and in middle-aged blood donors. *J Infect Dis* 1998;178(1):274–277.
26. Shor A, Kuo C-C, Patton DL. Detection of *Chlamydia pneumoniae* in coronary arterial fatty streaks and atherosclerotic plaques. *S Afr Med J* 1992;82:158–161.
27. Muhlestein JB, Hammond EH, Carlquist JF, et al. Increased incidence of *Chlamydia* species within the coronary arteries of patients with symptomatic atherosclerotic versus other forms of cardiovascular disease. *J Am Coll Cardiol* 1996;27:1555–1561.
28. Jackson LA, Campbell LA, Kuo CC, Rodriguez DI, Lee A, Grayston JT. Isolation of *Chlamydia pneumoniae* from a carotid endarterectomy specimen. *J Infect Dis* 1997;176(1):292–295.

29. Ramirez JA. Isolation of *Chlamydia pneumoniae* from the coronary artery of a patient with coronary atherosclerosis. The Chlamydia pneumoniae/Atherosclerosis Study Group. *Ann Intern Med* 1996;125(12):979–982.
30. Fong IW, Chiu B, Vira E, Fong MW, Jang D, Mahony J. Rabbit model for *Chlamydia pneumoniae* infection. *J Clin Microbiol* 1997;35(1):48–52.
31. Laitinen K, Laurila A, Pyhala L, Leinonen M, Saikku P. *Chlamydia pneumoniae* infection induces inflammatory changes in the aortas of rabbits. *Infect Immun* 1997;65(11):4832–4835.
32. Muhlestein JB, Anderson JL, Hammond EF, et al. Infection with *Chlamydia pneumoniae* accelerates the development of atherosclerosis and treatment with azithromycin prevents it in a rabbit model. *Circulation* 1998;97:633–636.
33. Moazed TC, Kuo C, Grayston JT, Campbell LA. Murine models of *Chlamydia pneumoniae* infection and atherosclerosis. *J Infect Dis* 1997;175(4):883–890.
34. Hu H, Pierce GN, Zhong G. The atherogenic effects of chlamydia are dependent on serum cholesterol and specific to *Chlamydia pneumoniae*. *J Clin Invest* 1999;103(5):747–753.
35. Saikku P, Laitinen K, Leinonen M. Animal models for *Chlamydia pneumoniae* infection. *Atherosclerosis* 1998;140(Suppl 1):S17–S19.
36. Liuba P, Karnani P, Pesonen E, et al. Endothelial dysfunction after repeated *Chlamydia pneumoniae* infection in apolipoprotein E-knockout mice. *Circulation* 2000;102(9):1039–1044.
37. Aalto-Setälä K, Laitinen K, Erkkilä L, et al. *Chlamydia pneumoniae* does not increase atherosclerosis in the aortic root of apolipoprotein E-deficient mice. *Arterioscl Thromb Vasc Biol* 2001;21(4):578–584.
38. Blessing E, Lin TM, Campbell LA, Rosenfeld ME, Lloyd D, Kuo C. *Chlamydia pneumoniae* induces inflammatory changes in the heart and aorta of normocholesterolemic C57BL/6J mice. *Infect Immun* 2000;68(8):4765–4768.
39. Gupta S, Leatham EW, Carrington D, Mendall MA, Kaski JC. Elevated *Chlamydia pneumoniae* antibodies, cardiovascular events, and azithromycin in male survivors of myocardial infarction. *Circulation* 1997;96(2):404–407.
40. Gurfinkel E, Bozovich G, Daroca A, Beck E, Mautner B. Randomised trial of roxithromycin in non-Q-wave coronary syndromes: ROXIS Pilot Study. ROXIS Study Group. *Lancet* 1997;350(9075):404–407.
41. Gurfinkel E, Bozovich G, Beck E, Testa E, Livellara B, Mautner B. Treatment with the antibiotic roxithromycin in patients with acute non-Q-wave coronary syndromes: the final report of the ROXIS Study. *Eur Heart J* 1999;20(2):121–127.
42. Anderson JL, Muhlestein JB, Carlquist J, et al. Randomized secondary prevention trial of azithromycin in patients with coronary artery disease and serological evidence for *Chlamydia pneumoniae* infection. The azithromycin in coronary artery disease: elimination of myocardial infection with Chlamydia (ACADEMIC) study. *Circulation* 1999;99:1540–1547.
43. Muhlestein JB, Anderson JL, Carlquist JF, et al. Randomized secondary prevention trial of azithromycin in patients with coronary artery disease: primary clinical results of the ACADEMIC study. *Circulation* 2000;102:1755–1760.
44. Neumann F, Kastrati A, Miethke T, et al. Treatment of *Chlamydia pneumoniae* infection with roxithromycin and effect on neointima proliferation after coronary stent placement (ISAR-3): a randomised, double-blind, placebo-controlled trial. *Lancet* 2001;357(9274):2085–2089.
45. Stone AFM, Mendall M, Kaski J-C, Gupta S, Camm J, Northfield T. Antibiotics against *Chlamydia pneumoniae* and *Helicobacter pylori* reduce further cardiovascular events in patients with acute coronary syndromes. *J Am Coll Cardiol* 2001;37(2A):349A.
46. Dunne MW. Rationale and design of a secondary prevention trial of antibiotic use in patients after myocardial infarction: the WIZARD (weekly intervention with Zithromax [azithromycin] for atherosclerosis and its related disorders) trial. *J Infect Dis* 2000;181(Suppl 3):S572–S578.
47. Coletta A, Thackray S, Nikitin N, Cleland JG. Clinical trials update: highlights of the scientific sessions of The American College of Cardiology 2002: LIFE, DANAMI 2, MADIT-2, MIRACLE-ICD, OVERTURE, OCTAVE, ENABLE 1 & 2, CHRISTMAS, AFFIRM, RACE, WIZARD, AZACS, REMATCH, BNP trial and HARDBALL. *Eur J Heart Failure* 2002;4(3):381–388.
48. Cercek B, Shah PK, Noc M, et al. Effect of short-term treatment with azithromycin on recurrent ischaemic events in patients with acute coronary syndrome in the Azithromycin in Acute Coronary Syndrome (AZACS) trial: a randomised controlled trial. *Lancet* 2003;361(9360):809–813.
49. Grayston JT. Secondary prevention antibiotic treatment trials for coronary artery disease. *Circulation* 2000;102(15):1742, 1743.
50. Gieffers J, Füüllgraf H, Jahn J, et al. *Chlamydia pneumoniae* infection in circulating human monocytes is refractory to antibiotic treatment. *Circulation* 2000;103:351–356.

51. Goodwin CS, Worsley BW. Microbiology of *Helicobacter pylori*. *Gastroenterol Clin N Am* 1993;22: 5–19.
52. Goodwin CS, Mendall MM, Northfield TC. *Helicobacter pylori* infection. *Lancet* 1997;349(9047): 265–269.
53. Wisniewski RM, Peura DA. *Helicobacter pylori*: beyond peptic ulcer disease. *Gastroenterologist* 1997; 5(4):295–305.
54. Mendall MA, Goggin PM, Molineaux N, et al. Relation of *Helicobacter pylori* infection and coronary heart disease. *Br Heart J* 1994;71(5):437–439.
55. Danesh J, Collins R, Peto R. Chronic infections and coronary heart disease: is there a link? *Lancet* 1997; 350(9075):430–436.
56. Danesh J, Peto R. Risk factors for coronary heart disease and infection with *Helicobacter pylori*: meta-analysis of 18 studies. *BMJ* 1998;316(7138):1130–1132.
57. Mendall MA, Patel P, Ballam L, Strachan D, Northfield TC. C reactive protein and its relation to cardiovascular risk factors: a population based cross sectional study. *BMJ* 1996;312(7038):1061–1065.
58. Birnie DH, Holme ER, McKay IC, Hood S, McColl KE, Hillis WS. Association between antibodies to heat shock protein 65 and coronary atherosclerosis: possible mechanism of action of *Helicobacter pylori* and other bacterial infections in increasing cardiovascular risk. *Eur Heart J* 1998;19(3):387–394.
59. Pasceri V, Cammarota G, Patti G, et al. *Circulation* 1998;97(17):1675–1679.
60. Mayr M, Kiechl S, Mendall MA, Willeit J, Wick G, Xu Q. Increased risk of atherosclerosis is confined to CagA-positive *Helicobacter pylori* strains: prospective results from the Bruneck study. *Stroke* 2003; 34(3):610–615.
61. Kowalski M, Rees W, Konturek PC, et al. Detection of *Helicobacter pylori* specific DNA in human atheromatous coronary arteries and its association to prior myocardial infarction and unstable angina. *Dig Liver Dis* 2002;34(6):398–402.
62. (No authors listed). Case Records of the Massachusetts General Hospital. Weekly clinicopathological exercises: case 39-1983. *N Engl J Med* 1983;309:782–789.
63. Taylor-Robinson D. Infections due to species of *Mycoplasma* and *Ureaplasma*: an update. *Clin Infect Dis* 1996;23:671–684.
64. Luby JP. Pneumonia caused by *Mycoplasma pneumoniae* infection. *Clin Chest Med* 1991;12:237–244.
65. Horne BD, Muhlestein JB, Carlquist JF, et al. IgA seropositivity to *mycoplasma pneumoniae* predicts the diagnosis of coronary artery disease. *J Am Coll Cardiol* 2000;35(2 Suppl A):312A.
66. Lim TH, Muhlestein JB, Carlquist JF, et al. *Mycoplasma pneumoniae* high IgA titer but not IgG predicts increased hazard of death or myocardial infarction among patients with angiographically-defined coronary artery disease. *J Am Coll Cardiol* 2002;39(5 Suppl A):327A.
67. Higuchi Mde L, Higuchi-Dos-Santos MH, Pierri H, et al. *Mycoplasma pneumoniae* and *Chlamydia pneumoniae* in calcified nodules of aortic stenotic valves. *Revista Instituto Medicina Tropical Sao Paulo* 2002;44(4):209–212.
68. Maraha B, Berg H, Scheffer GJ, et al. Correlation between detection methods of *Chlamydia pneumoniae* in atherosclerotic and non-atherosclerotic tissues. *Diagn Microbiol Infect Dis* 2001;39(3):139–143.
69. Churchill AE, Biggs PM. Herpes-type virus isolated in cell culture from tumors of chickens with Marek's disease. II. Studies in vivo. *J Natl Cancer Inst* 1968;41(4):951–956.
70. Minick CR, Fabricant CG, Fabricant J, Litrenta MM. Atheroarteriosclerosis induced by infection with a herpes virus. *Am J Pathol* 1979;96(3):673–706.
71. Adam E, Melnick JL, Probstfield JL, et al. High levels of cytomegalovirus antibody in patients requiring vascular surgery for atherosclerosis. *Lancet* 1987;2(8554):291–293.
72. Melnick JL, Hu C, Burek J, Adam E, DeBakey ME. Cytomegalovirus DNA in arterial walls of patients with atherosclerosis. *J Med Virol* 1994;42(2):170–174.
73. Grattan MT, Moreno-Cabral CE, Starnes VA, Oyer PE, Stinson EB, Shumway NE. Cytomegalovirus infection is associated with cardiac allograft rejection and atherosclerosis. *JAMA* 1989;261(24):3561–3566.
74. Muhlestein JB, Horne BD, Carlquist JF, et al. Cytomegalovirus seropositivity and C-reactive protein have independent and combined predictive value for mortality in patients with angiographically demonstrated coronary artery disease. *Circulation* 2000;102(16):1917–1923.
75. Horne BD, Muhlestein JB, Carlquist JF, Renlund DG, Bair TL, Anderson JL. Cytomegalovirus: strength of antibody response and its relationship to risk of mortality among patients with angiographic coronary disease. *J Am Coll Cardiol* 2003;41(6 Suppl A):367A.

76. Smieja M, Gnarpe J, Lonn E, et al. Heart Outcomes Prevention Evaluation (HOPE) Study Investigators. Multiple infections and subsequent cardiovascular events in the Heart Outcomes Prevention Evaluation (HOPE) Study. *Circulation* 2003;107(2):251–257.
77. Hajjar DP, Pomerantz KB, Falcone DJ, et al. Herpes simplex virus infection in human arterial cells: implications in arteriosclerosis. *J Clin Invest* 1987;80:1317–1321.
78. Visser MR, Vercellotti GM. Herpes simplex virus and atherosclerosis. *Eur Heart J* 1993;14:39–42.
79. Key NS, Bach RR, Vercellotti GM, et al. Herpes simplex virus type I does not require productive infection to induce tissue factor in human umbilical vein endothelial cells. *Lab Invest* 1993;68:645–651.
80. Span AH, van Dam-Mieras MC, Mullers W, et al. The effect of virus infection on the adherence of leukocytes or platelets to endothelial cells. *Eur J Clin Invest* 1991;21:331–338.
81. Visser MR, Jacob HS, Goodman JL, et al. Granulocyte-mediated injury to herpes simplex virus-infected human endothelium. *Lab Invest* 1989;60:296–304.
82. Constans J, Marchand JM, Conri C, et al. Asymptomatic atherosclerosis in HIV-patients: a case control ultrasound study. *Ann Med* 1995;27:683–685.
83. Paton P, Tabib A, Loire R, Tete R. Coronary lesions and immunodeficiency virus infection. *Res Virol* 1993;144:225–231.
84. Spodick DH, Flessas AP, Johnson MM. Association of acute respiratory symptoms with onset of acute myocardial infarction: prospective investigation of 150 consecutive patients and matched control patients. *Am J Cardiol* 1984;53:481–482.
85. Bainton D, Jones GR, Hole D. Influenza and ischemic heart disease: a possible trigger for acute myocardial infarction? *Int J Epidemiol* 1978;7:231–239.
86. Zheng ZJ, Mittleman MA, Tofler GH, et al. Infections prior to acute MI onset. *J Am Coll Cardiol* 1998;31(Suppl A):132A.
87. Abinader EG, Sharif DS, Omary M. Inferior wall myocardial infarction preceded by acute exudative pharyngitis in young males. *Isr J Med Sci* 1993;29:764–769.
88. Collins SD. Excess mortality from causes other than influenza and pneumonia during influenza epidemics. *Public Health Rep* 1932;47:2159–2180.
89. Naghavi M, Wyde P, Litovsky S, et al. Influenza infection exerts prominent inflammatory and thrombotic effects on the atherosclerotic plaques of apolipoprotein E-deficient mice. *Circulation* 2003;107(5):762–768.
90. Naghavi M, Barlas Z, Siadaty S, Naguib S, Madjid M, Casscells W. Association of influenza vaccination and reduced risk of recurrent myocardial infarction. *Circulation* 2000;102(25):3039–3045.
91. Lavallée P, Perchaud V, Gautier-Bertrand M, Grabli D, Amarenco P. Association between influenza vaccination and reduced risk of brain infarction. *Stroke* 2002;33:513–518.
92. Jackson LA, Yu O, Heckbert SR, et al. Vaccine Safety Datalink Study Group. Influenza vaccination is not associated with a reduction in the risk of recurrent coronary events. *Am J Epidemiol* 2002;156(7):634–640.
93. Gurfinkel EP, de la Fuente RL, Mendiz O, Mautner B. Influenza vaccine pilot study in acute coronary syndromes and planned percutaneous coronary interventions: the FLU Vaccination Acute Coronary Syndromes (FLUVACS) Study. *Circulation* 2002;105(18):2143–2147.
94. Epstein SE, Zhou YF, Zhu J. Infection and atherosclerosis: emerging mechanistic paradigms. *Circulation* 1999;100:e20–e28.
95. Zhu J, Quyyumi AA, Norman JE, et al. Effects of total pathogen burden on coronary artery disease risk and C-reactive protein levels. *Am J Cardiol* 2000;85:140–146.
96. Zhu J, Nieto FJ, Horne BD, Anderson JL, Muhlestein JB, Epstein SE. Prospective study of pathogen burden and risk of myocardial infarction or death. *Circulation* 2001;103(1):45–51.
97. Rupprecht HJ, Blankenberg S, Bickel C, et al. AutoGene Investigators. Impact of viral and bacterial infectious burden on long-term prognosis in patients with coronary artery disease. *Circulation* 2001;104(1):25–31.
98. Espinola-Klein C, Rupprecht HJ, Blankenberg S, et al. AtheroGene Investigators. Impact of infectious burden on extent and long-term prognosis of atherosclerosis. *Circulation* 2002;105(1):15–21.
99. Muhlestein JB, Anderson JL. Infectious serology and atherosclerosis: how burdensome is the risk? *Circulation* 2003;107(2):220–222.
100. Zhu J, Quyyumi AA, Norman JE, Csako G, Epstein SE. The possible role of hepatitis A virus in the pathogenesis of atherosclerosis. *J Am Coll Cardiol* 1999;33(2 Suppl A):4A.
101. Leinonen M, Linnanmaki E, Mattila K, et al. Circulating immune complexes containing chlamydial lipopolysaccharide in acute myocardial infarction. *Microb Pathogen* 1990;9(1):67–73.



102. Thom DH, Wang SP, Grayston JT, et al. *Chlamydia pneumoniae* strain TWAR antibody and angiographically demonstrated coronary artery disease. *Arterioscl Thromb* 1991;11(3):547–551.
103. Thom DH, Grayston JT, Siscovick DS, Wang SP, Weiss NS, Daling JR. Association of prior infection with *Chlamydia pneumoniae* and angiographically demonstrated coronary artery disease. *JAMA* 1992; 268(1):68–72.
104. Linnanmaki E, Leinonen M, Mattila K, Nieminen MS, Valtonen V, Saikku P. *Chlamydia pneumoniae*-specific circulating immune complexes in patients with chronic coronary heart disease. *Circulation* 1993; 87(4):1130–1134.
105. Melnick SL, Shahar E, Folsom AR, et al. Past infection by *Chlamydia pneumoniae* strain TWAR and asymptomatic carotid atherosclerosis. Atherosclerosis Risk in Communities (ARIC) Study Investigators. *Am J Med* 1993;95(5):499–504.
106. Puolakkainen M, Kuo CC, Shor A, Wang SP, Grayston JT, Campbell LA. Serological response to *Chlamydia pneumoniae* in adults with coronary arterial fatty streaks and fibrolipid plaques. *J Clin Microbiol* 1993;31(8):2212–2214.
107. Saikku P. *Chlamydia pneumoniae* infection as a risk factor in acute myocardial infarction. *Eur Heart J* 1993;14(Suppl K):S62.
108. Dahlen GH, Boman J, Birgander LS, Lindblom B. Lp(a) lipoprotein, IgG, IgA and IgM antibodies to *Chlamydia pneumoniae* and HLA class II genotype in early coronary artery disease. *Atherosclerosis* 1995;114(2):165–174.
109. Mendall MA, Carrington D, Strachan D, et al. *Chlamydia pneumoniae*: risk factors for seropositivity and association with coronary heart disease. *J Infect* 1995;30(2):121–128.
110. Patel P, Mendall MA, Carrington D, et al. Association of *Helicobacter pylori* and *Chlamydia pneumoniae* infections with coronary heart disease and cardiovascular risk factors. *BMJ* 1995;311(7007):711–714.
111. Cook PJ, Honeybourne D, Lip GY, Beevers DG, Wise R. *Chlamydia pneumoniae* and acute arterial thrombotic disease. *Circulation* 1995;92(10):3148, 3149.
112. Miettinen H, Lehto S, Saikku P, et al. Association of *Chlamydia pneumoniae* and acute coronary heart disease events in non-insulin dependent diabetic and non-diabetic subjects in Finland. *Eur Heart J* 1996; 17(5):682–688.
113. Wimmer ML, Sandmann-Strupp R, Saikku P, Haberl RL. Association of chlamydial infection with cerebrovascular disease. *Stroke* 1996;27(12):2207–2210.
114. Ossewaarde JM, Feskens EJ, De Vries A, Vallinga CE, Kromhout D. *Chlamydia pneumoniae* is a risk factor for coronary heart disease in symptom-free elderly men, but *Helicobacter pylori* and cytomegalovirus are not. *Epidemiol Infect* 1998;120(1):93–99.
115. Gupta S, Leatham EW, Carrington D, Mendall MA, Kaski JC, Camm AJ. Elevated *Chlamydia pneumoniae* antibodies, cardiovascular events, and azithromycin in male survivors of myocardial infarction. *Circulation* 1997;96(2):404–407.
116. Blasi F, Cosentini R, Raccanelli R, et al. A possible association of *Chlamydia pneumoniae* infection and acute myocardial infarction in patients younger than 65 years of age. *Chest* 1997;112(2):309–312.
117. Kark JD, Leinonen M, Paltiel O, Saikku P. *Chlamydia pneumoniae* and acute myocardial infarction in Jerusalem. *Int J Epidemiol* 1997;26(4):730–738.
118. Fagerberg B, Gnarpe J, Gnarpe H, Agewall S, Wikstrand J. *Chlamydia pneumoniae* but not cytomegalovirus antibodies are associated with future risk of stroke and cardiovascular disease: a prospective study in middle-aged to elderly men with treated hypertension. *Stroke* 1999;30(2):299–305.
119. Miyashita N, Toyota E, Sawayama T, et al. Association of chronic infection of *Chlamydia pneumoniae* and coronary heart disease in the Japanese. *Intern Med* 1998;37(11):913–916.
120. Altman R, Rouvier J, Scazziota A, Absi RS, Gonzalez C. Lack of association between prior infection with *Chlamydia pneumoniae* and acute or chronic coronary artery disease. *Clin Cardiol* 1999;22(2):85–90.
121. Ridker PM, Kundsinn RB, Stampfer MJ, Poulin S, Hennekens CH. Prospective study of *Chlamydia pneumoniae* IgG seropositivity and risks of future myocardial infarction. *Circulation* 1999;99(9):1161–1164.
122. Siscovick DS, Schwartz SM, Corey L, et al. *Chlamydia pneumoniae*, herpes simplex virus type 1, and cytomegalovirus and incident myocardial infarction and coronary heart disease death in older adults: the Cardiovascular Health Study. *Circulation* 2000;102(19):2335–2340.
123. Espinola-Klein C, Rupprecht HJ, Blankenberg S, et al. Are morphological or functional changes in the carotid artery wall associated with *Chlamydia pneumoniae*, *Helicobacter pylori*, cytomegalovirus, or herpes simplex virus infection? *Stroke* 2000;31(9):2127–2133.
124. Mayr M, Kiechl S, Willeit J, Wick G, Xu Q. Infections, immunity, and atherosclerosis: associations of antibodies to *Chlamydia pneumoniae*, *Helicobacter pylori*, and cytomegalovirus with immune reactions to heat-shock protein 60 and carotid or femoral atherosclerosis. *Circulation* 2000;102(8):833–839.

125. Kosaka C, Hara K, Komiyama Y, Takahashi H. Possible role of chronic infection with *Chlamydia pneumoniae* in Japanese patients with acute myocardial infarction. *Jpn Circ J* 2000;64(11):819–824.
126. Shimada K, Mokuno H, Watanabe Y, Sawano M, Daida H, Yamaguchi H. High prevalence of seropositivity for antibodies to Chlamydia-specific lipopolysaccharide in patients with acute coronary syndrome. *J Cardiovasc Risk* 2000;7(3):209–213.
127. Tontsch D, Noll B, Schaefer JR, Herzum M, Maisch B, Goeke B. Hyperinsulinemia, lipoprotein (a), and Chlamydia pneumoniae antibodies—are they risk factors or serologic predictors for progression of coronary artery disease? *Angiology* 2000;51(10):831–836.
128. Hoffmeister A, Rothenbacher D, Wanner P, et al. Seropositivity to chlamydial lipopolysaccharide and *Chlamydia pneumoniae*, systemic inflammation and stable coronary artery disease: negative results of a case-control study. *J Am Coll Cardiol* 2000;35(1):112–128.
129. Song YG, Kwon HM, Kim JM, et al. Serologic and histopathologic study of *Chlamydia pneumoniae* infection in atherosclerosis: a possible pathogenetic mechanism of atherosclerosis induced by *Chlamydia pneumoniae*. *Yonsei Med J* 2000;41(3):319–327.
130. Blanchard JF, Armenian HK, Peeling R, Friesen PP, Shen C, Brunham RC. The relation between *Chlamydia pneumoniae* infection and abdominal aortic aneurysm: case-control study. *Clin Infect Dis* 2000;30(6):946–947.
131. Wald NJ, Law MR, Morris JK, Zhou X, Wong Y, Ward ME. *Chlamydia pneumoniae* infection and mortality from ischaemic heart disease: large prospective study. *BMJ* 2000;321(7255):204–207.
132. Schmidt C, Hulthe J, Wikstrand J, et al. *Chlamydia pneumoniae* seropositivity is associated with carotid artery intima-media thickness. *Stroke* 2000;31(7):1526–1531.
133. Elkind MS, Lin IF, Grayston JT, Sacco RL. *Chlamydia pneumoniae* and the risk of first ischemic stroke: the Northern Manhattan Stroke Study. *Stroke* 2000;31(7):1521–1525.
134. Romeo F, Martuscelli E, Chirieleo G, et al. Seropositivity against Chlamydia pneumoniae in patients with coronary atherosclerosis. *Clin Cardiol* 2000;23(5):327–330.
135. Sharma N, Rutherford JD, Grayston JT, King LP, Jialal I, Andrews TC. Association between C-reactive protein, anti-Chlamydia pneumoniae antibodies, and vascular function in healthy adults. *Am J Cardiol* 2001;87(1):119–121, A9.
136. Smieja M, Cronin L, Levine M, Goldsmith CH, Yusuf S, Mahony JB. Previous exposure to *Chlamydia pneumoniae*, *Helicobacter pylori* and other infections in Canadian patients with ischemic heart disease. *Can J Cardiol* 2001;17(3):270–276.
137. Katsenis C, Kouskouni E, Kolokotronis L, Rizos D, Dimakakos P. The significance of *Chlamydia pneumoniae* in symptomatic carotid stenosis. *Angiology* 2001;52(9):615–619.
138. Mendis S, Arseculeratne YM, Withana N, Samitha S. *Chlamydia pneumoniae* infection and its association with coronary heart disease and cardiovascular risk factors in a sample South Asian population. *Int J Cardiol* 2001;79(2-3):191–196.
139. Shimada K, Daida H, Mokuno H, et al. Association of seropositivity for antibody to Chlamydia-specific lipopolysaccharide and coronary artery disease in Japanese men. *Jpn Circ J* 2001;65(3):182–187.
140. Haubitz M, Brunkhorst R. C-reactive protein and chronic *Chlamydia pneumoniae* infection—long-term predictors for cardiovascular disease and survival in patients on peritoneal dialysis. *Nephrol Dialysis Transplant* 2001;16(4):809–815.
141. Sander D, Winbeck K, Klingelhofer J, Etgen T, Conrad B. Enhanced progression of early carotid atherosclerosis is related to *Chlamydia pneumoniae* (Taiwan acute respiratory) seropositivity. *Circulation* 2001;103(10):1390–1395.
142. Kuo CC, Shor A, Campbell LA, Fukushi H, Patton DL, Grayston JT. Demonstration of *Chlamydia pneumoniae* in atherosclerotic lesions of coronary arteries. *J Infect Dis* 1993;167(4):841–849.
143. Davidson M, Kuo CC, Middaugh JP, et al. Confirmed previous infection with *Chlamydia pneumoniae* (TWAR) and its presence in early coronary atherosclerosis. *Circulation* 1998;98(7):628–633.
144. Kuo CC, Coulson AS, Campbell LA, et al. Detection of *Chlamydia pneumoniae* in atherosclerotic plaques in the walls of arteries of lower extremities from patients undergoing bypass operation for arterial obstruction. *J Vasc Surg* 1997;26(1):29–31.
145. Jackson LA, Campbell LA, Kuo CC, Rodriguez DI, Lee A, Grayston JT. Isolation of *Chlamydia pneumoniae* from a carotid endarterectomy specimen. *J Infect Dis* 1997;176(1):292–295.
146. Jackson LA, Campbell LA, Schmidt RA, et al. Specificity of detection of *Chlamydia pneumoniae* in cardiovascular atheroma: evaluation of the innocent bystander hypothesis. *Am J Pathol* 1997;150(5):1785–1790.
147. Grayston JT, Kuo CC, Coulson AS, et al. *Chlamydia pneumoniae* (TWAR) in atherosclerosis of the carotid artery. *Circulation* 1995;92(12):3397–3400.

148. Campbell LA, O'Brien ER, Cappuccio AL, et al. Detection of *Chlamydia pneumoniae* TWAR in human coronary atherectomy tissues. *J Infect Dis* 1995;172(2):585–588.
149. Kuo CC, Grayston JT, Campbell LA, Goo YA, Wissler RW, Benditt EP. *Chlamydia pneumoniae* (TWAR) in coronary arteries of young adults (15–34 years old). *Proc Natl Acad Sci USA* 1995;92(15):6911–6814.
150. Kuo CC, Gown AM, Benditt EP, Grayston JT. Detection of *Chlamydia pneumoniae* in aortic lesions of atherosclerosis by immunocytochemical stain. *Arterioscl Thromb* 1993;13(10):1501–1504.
151. Shor A, Phillips JI, Ong G, Thomas BJ, Taylor-Robinson D. *Chlamydia pneumoniae* in atheroma: consideration of criteria for causality. *J Clin Pathol* 1998;51(11):812–817.
152. Maass M, Bartels C, Kruger S, Krause E, Engel PM, Dalhoff K. Endovascular presence of *Chlamydia pneumoniae* DNA is a generalized phenomenon in atherosclerotic vascular disease. *Atherosclerosis* 1998;140(Suppl 1):S25–S30.
153. Maass M, Gieffers J, Krause E, Engel PM, Bartels C, Solbach W. Poor correlation between immunofluorescence serology and polymerase chain reaction for detection of vascular *Chlamydia pneumoniae* infection in coronary artery disease patients. *Med Microbiol Immunol* 1998;187(2):103–106.
154. Wong Y, Thomas M, Tsang V, Gallagher PJ, Ward ME. The prevalence of *Chlamydia pneumoniae* in atherosclerotic and nonatherosclerotic blood vessels of patients attending for redo and first time coronary artery bypass graft surgery. *J Am Coll Cardiol* 1999;33(1):152–156.
155. Ouchi K, Fujii B, Kanamoto Y, Karita M, Shirai M, Nakazawa T. *Chlamydia pneumoniae* in coronary and iliac arteries of Japanese patients with atherosclerotic cardiovascular diseases. *J Med Microbiol* 1998;47(10):907–913.
156. Paterson DL, Hall J, Rasmussen SJ, Timms P. Failure to detect *Chlamydia pneumoniae* in atherosclerotic plaques of Australian patients. *Pathology* 1998;30(2):169–172.
157. Lindholt JS, Ostergard L, Henneberg EW, Fasting H, Andersen P. Failure to demonstrate *Chlamydia pneumoniae* in symptomatic abdominal aortic aneurysms by a nested polymerase chain reaction (PCR). *Eur J Vasc Endovasc Surg* 1998;15(2):161–164.
158. Juvonen J, Juvonen T, Laurila A, et al. Demonstration of *Chlamydia pneumoniae* in the walls of abdominal aortic aneurysms. *J Vasc Surg* 1997;25(3):499–505.
159. Blasi F, Denti F, Erba M, et al. Detection of *Chlamydia pneumoniae* but not *Helicobacter pylori* in atherosclerotic plaques of aortic aneurysms. *J Clin Microbiol* 1996;34(11):2766–2769.
160. Weiss SM, Roblin PM, Gaydos CA, et al. Failure to detect *Chlamydia pneumoniae* in coronary atheromas of patients undergoing atherectomy. *J Infect Dis* 1996;173(4):957–962.
161. Yamashita K, Ouchi K, Shirai M, Gondo T, Nakazawa T, Ito H. Distribution of *Chlamydia pneumoniae* infection in the atherosclerotic carotid artery. *Stroke* 1998;29(4):773–778.
162. Wong Y, Thomas M, Tsang V, Gallagher PJ, Ward ME. The prevalence of *Chlamydia pneumoniae* in atherosclerotic and nonatherosclerotic blood vessels of patients attending for redo and first time coronary artery bypass graft surgery. *J Am Coll Cardiol* 1999;33(1):152–156.
163. Virok D, Kis Z, Karai L, et al. *Chlamydia pneumoniae* in atherosclerotic middle cerebral artery. *Stroke* 2001;32(9):1973–1976.
164. Grattan et al. *Clin Cardiol* 1991;14:16–20.

# IV

---

## BIOMARKERS OF HEMODYNAMIC STRESS

---



# 21

---

## Biology of Natriuretic Peptides

---

*Charlotte Kragelund, MD  
and Torbjørn Omland, MD, PhD, MPH*

### CONTENTS

THE NATRIURETIC PEPTIDE FAMILY  
DISCOVERY OF THE NATRIURETIC PEPTIDES  
SYNTHESIS AND RELEASE OF NATRIURETIC PEPTIDES  
NATRIURETIC PEPTIDE SIGNALING  
CLEARANCE OF NATRIURETIC PEPTIDES  
PHYSIOLOGICAL ACTIONS OF NATRIURETIC PEPTIDES  
NATRIURETIC PEPTIDES IN CVDs  
CONCLUSION  
REFERENCES

---

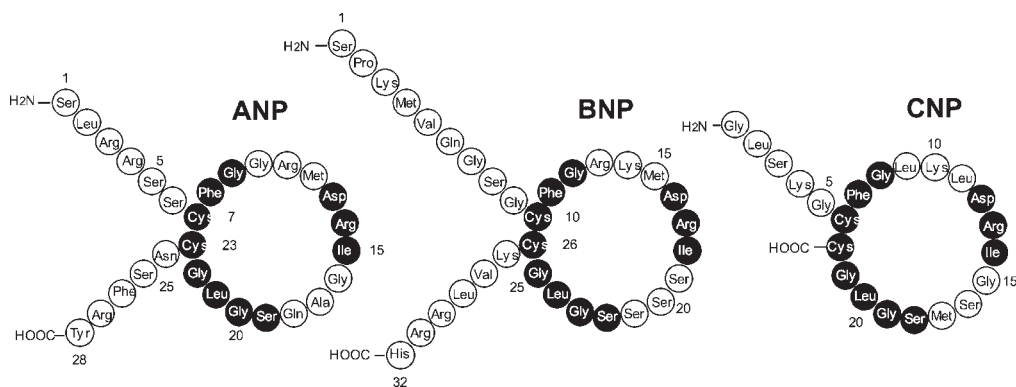
### SUMMARY

The natriuretic peptide family consists of a group of structurally similar, but genetically distinct, peptide hormones that play a major role in the regulation of cardiovascular, endocrine, and renal homeostasis. Since the discovery of atrial natriuretic peptide almost 25 yr ago, remarkable progress has been made in the field of natriuretic peptide research. This chapter reviews current knowledge in biology of the natriuretic peptides, including mechanisms of synthesis and release, biological effects, and clearance.

The predominant stimulus controlling the synthesis and release of natriuretic peptides from cardiac atria and ventricles is wall stretch. However, recent evidence suggests that ischemia per se may be an additional factor influencing synthesis and release. The biological effects of the natriuretic peptides are mediated via binding to cell surface-associated natriuretic peptide receptors. The natriuretic peptide receptors are expressed widely in the cardiovascular system and have also been identified in the lungs, kidneys, skin, platelets and pre-synaptic sympathetic nerve fibers. Natriuretic peptides are functional antagonists to the major vasoconstrictor neurohormonal axes, exert potent natriuretic and diuretic effects in the kidneys, and modulate cell growth, apoptosis, and proliferation in vascular smooth muscle cells and cardiomyocytes. The natriuretic peptide system is activated in a broad spectrum of cardiovascular diseases, including systolic and diastolic right and left ventricular dysfunction, acute coronary syndromes, stable coronary heart disease, valvular heart disease, and left- and right-ventricular hypertrophy.

**Key Words:** Natriuretic peptides; receptors; cardiovascular function.

From: *Contemporary Cardiology:  
Cardiovascular Biomarkers: Pathophysiology and Disease Management*  
Edited by: David A. Morrow © Humana Press Inc., Totowa, NJ



**Fig. 1.** Structure of natriuretic peptides. ANP (28 amino acids), BNP (32 amino acids), and CNP (22 amino acids) are cyclic peptides with a high degree of primary structure homology. Identical amino acids are enclosed in black circles.

## THE NATRIURETIC PEPTIDE FAMILY

The natriuretic peptide family consists of a group of structurally similar (Fig. 1) but genetically distinct peptide hormones that play a major role in the regulation of cardiovascular, endocrine, and renal homeostasis (1,2). Whereas circulating A-type (atrial) natriuretic peptide (ANP) and B-type natriuretic peptide (BNP) are primarily of cardiac origin (3,4), vascular endothelium and the central nervous system (CNS) have been identified as major sites of C-type natriuretic peptide (CNP) synthesis (5). Other structurally related peptides include D-type natriuretic peptide, derived from the venom of the green mamba (*Dendroaspis angusticeps*) (6,7); urodilatin, a product of alternative processing of proANP in the distal tubules of the kidney (8); and guanylin and uroguanylin, intestinal epithelium-derived peptides which are involved in water absorption (9–11). Although all of these molecules are classified as natriuretic peptides, they possess additional important properties, including vasodilatory, antiproliferative (12), antifibrotic (13), and sympatho-inhibitory (14) effects. Some natriuretic peptides are more likely to function as autocrine or paracrine factors rather than as circulating hormones. CNP, for example, is unlikely to participate in the regulation of renal sodium excretion despite being termed a natriuretic peptide.

## DISCOVERY OF THE NATRIURETIC PEPTIDES

A series of seminal experiments performed in the mid-1950s raised suspicion that the heart may function as an endocrine organ. Early electron microscopy studies of cardiac atria showed electron-dense “specific atrial granules,” which morphologically resembled secretory granules in endocrine cells (15,16). At the same time, increased urinary flow after balloon stretching of the canine left atrium was reported (17,18). The content, physiological function, and significance of the atrial granules remained unknown until a series of highly original experiments conducted by Adolfo de Bold and colleagues was published more than two decades later. In 1979, de Bold (19) reported that atrial granularity was associated with changes in water and electrolyte balance. In a subsequent landmark experiment published in 1981, homogenized atrial and ventricular tissue were injected into rats. Whereas injection of the atrial extract caused hypotension, diuresis, and natriuresis, no such effect was observed after injection of the ventricular extract (20). This finding documented the endocrine activity of the cardiac atria and led de Bold to postulate the existence of an

Table 1  
Biochemical Characteristics of Natriuretic Peptides<sup>a</sup>

Characteristic	ANP	BNP	CNP
Precursor	preproANP (1-151)	preproBNP (1-134)	preproCNP (1-126)
Prohormone (i.e., precursor without signal peptide)	proANP (1-126)	proBNP (1-108)	proCNP (1-103)
Biologically active hormone (C-terminal fragments of prohormone)	ANP 1-28 (proANP 99-126)	BNP 1-32 (proBNP 77-108)	CNP 1-22 CNP 1-53
Circulating N-terminal fragments of prohormones	NT-proANP (proANP 1-98) proANP 1-30, proANP 31-67,	NT-proBNP (proBNP 1-76) proBNP 1-98	NT-proCNP
Clearance mechanisms	NPR-C, NEP	NPR-C, NEP	NPR-C, NEP
Plasma half-life	3 min	21 min	3 min

<sup>a</sup>NPR-C, natriuretic peptide receptor-C; NEP, neutral endopeptidase.

“atrial natriuretic factor.” During the next few years, the polypeptide today known as atrial natriuretic peptide or ANP was purified, sequenced, and synthesized (21,22).

In 1988, Sudoh et al. (23) isolated a peptide with biological activity similar to that of ANP from pig brain. The peptide was originally termed *brain natriuretic peptide* (BNP). The ventricular myocardium was later identified as the main source of circulating BNP (4), and, thus, B-type natriuretic peptide is now the more commonly used name of this peptide. In 1990, a third member of the natriuretic peptide family, CNP, was also isolated from porcine brain by the same group of researchers who had identified BNP (24).

## SYNTHESIS AND RELEASE OF NATRIURETIC PEPTIDES

### *A-Type Natriuretic Peptide*

ANP is a cyclic 28 amino acid polypeptide predominantly synthesized and secreted by atrial cardiomyocytes in response to wall stretch in the normal adult heart (21,22). The messenger RNA transcript for ANP is approx 1 kb and encodes a 126 amino acid precursor protein, proANP (25) (Table 1). The human ANP gene is located on chromosome 1. ANP is stored in atrial granules as the C-terminal part of intact proANP. On secretion, proANP is cleaved by the cardiac serine protease corin into a 98 amino acid N-terminal fragment (NT-proANP) and the biologically active ANP in equimolar amounts (26,27). NT-proANP circulates predominantly as the 98 amino acid peptide (28), but there is some evidence to suggest further subdivision into smaller fragments that may possess biological activity (29) (Table 1).

Ventricular synthesis of ANP is high in late fetal and early neonatal life but is rapidly reduced within the first few weeks after birth (30,31). Volume or pressure overload of the cardiac ventricles, leading to ventricular hypertrophy, is associated with ventricular re-expression of the gene for ANP (32). In fact, expression of the genes encoding ANP and BNP is considered a reliable marker of the hypertrophic program in experimental models associated with ventricular hypertrophy. The predominant stimulus for ANP release appears to be myocyte stretch, rather than transmural pressure load (33) (Table 2). In vivo, plasma ANP levels increase rapidly in response to pressure as well as volume loading (34–36),



Table 2  
Principal Causes of Elevated Plasma Levels of ANP and BNP

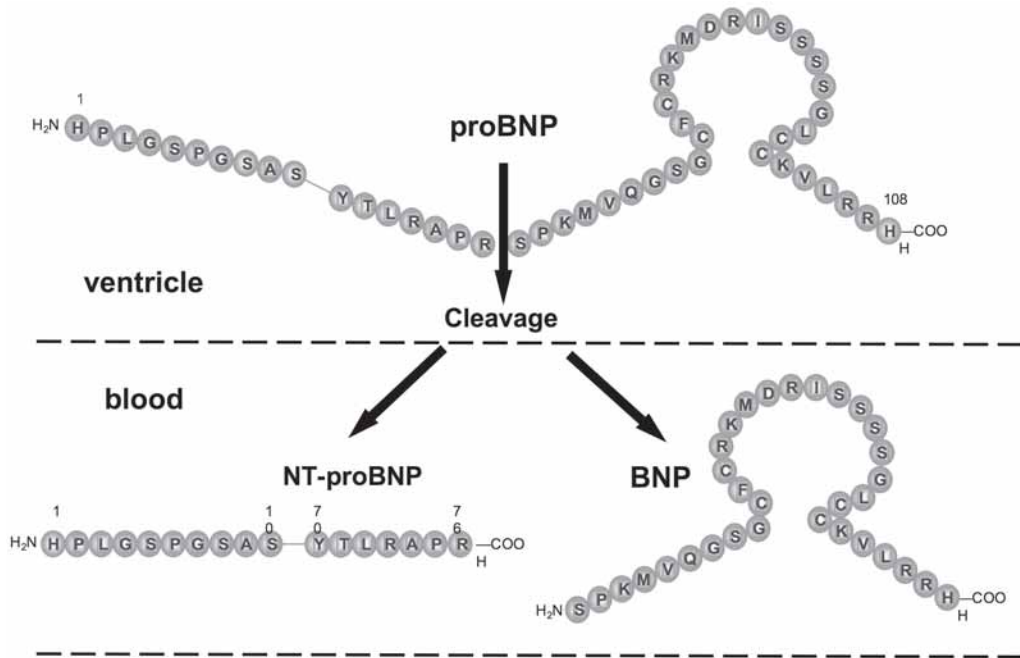
- 
- Elevated stretch of the myocardium owing to impaired systolic and/or diastolic function
  - Volume expansion and consequent elevated pressure/distension (e.g., renal failure)
  - Decreased renal clearance
  - Neurohormonal and cytokine stimulation
  - Myocardial ischemia
  - Hypoxia
  - Tachycardia
- 

and increased circulating levels of ANP are seen in many cardiovascular disorders (37). The cardiac ventricles contribute significantly to circulating ANP concentrations both in animal models and in patients with left ventricular (LV) dysfunction and hypertrophy (38,39). Although the concentration of ANP is higher in the atria than in the ventricle, the larger mass of the left ventricle means that the ventricular myocardium becomes a major source of circulating ANP and NT-proANP in failing hearts (40,41). ANP expression and release from cardiomyocytes can also be stimulated by neurohormones, including norepinephrine, angiotensin II (42), endothelin-1 (ET-1) (43), glucocorticoids (44), and proinflammatory cytokines (41,45). Activation of neurohormonal and inflammatory systems is characteristic of heart failure and can contribute to the increase in ANP levels seen in this clinical syndrome. Other stimuli for ANP synthesis include hypoxia (46) and possibly tachycardia independently of wall stretch (47).

### ***B-Type Natriuretic Peptide***

BNP is a predominantly cardiac-derived, cyclic 32 amino acid polypeptide with a high degree of primary structure homology with ANP (2) (Fig. 1). Human BNP is encoded by a single-copy gene located on chromosome 1 consisting of three exons and two introns (48,49). The posttranslational processing of the BNP precursor gene seems to differ from that of the human ANP precursor, and the processing of proBNP to NT-proBNP and the 32 amino acid biologically active BNP is less well defined than for proANP. In vitro experiments have suggested that the proteolytic enzyme furin is responsible for specific cleavage of proBNP into the N- and C-terminal fragments (50). However, a family of peptides is derived from the BNP gene (51,52). In human cardiac tissue, BNP appears to be found predominantly in the 32 amino acid form, but a significant amount is also stored as the intact 108 amino acid precursor peptide proBNP (4). In contrast to proANP, proBNP is only partially stored in granules, and the regulation of BNP synthesis and secretion appears to take place at the level of gene expression (37). The biologically active C-terminal fragment (BNP); the 76 amino acid N-terminal fragment (NT-proBNP); and other high-molecular-weight fragments, possibly intact proBNP 1-108, are each found circulating in human plasma (52–55) (Table 1). The processing of proBNP to NT-proBNP and BNP probably occurs both intracellularly and in the circulation. Figure 2 illustrates the amino acid sequences of proBNP and of the C- and N-terminal fragments, and Table 3 summarizes the characteristics of BNP and NT-proBNP.

In contrast to ANP, BNP is produced both in the atria and in the ventricles in the normal human heart (4,56) (Table 4). Circulating concentrations in healthy subjects are still lower for BNP than for ANP (56,57). In addition to production by atrial and ventricular cardio-



**Fig. 2.** Simplified schematic drawing showing cleavage of proBNP into biologically active C-terminal fragment, BNP, and inactive N-terminal fragment, NT-proBNP. It is likely that the processing of proBNP in vivo is substantially more complex (*see text*).

**Table 3**  
Characteristics of BNP and NT-proBNP<sup>a</sup>

Characteristic	BNP	NT-proBNP
Prohormone fragment	C-terminal (proBNP 77-108)	N-terminal (proBNP 1-76)
Molecular mass	3.5 kDa	8.5 kDa
Physiological activity	Active	Probably inactive
Plasma half-life	21 min	60–120 min
FDA-approved cutoff values for heart failure diagnosis	100 pg/mL	Age < 75 yr: 125 pg/mL; age > 75 yr: 450 pg/mL
Clearance mechanisms	Clearance receptors (NPR-C), NEP	Unknown, possibly renal clearance
Analysis	Whole blood and EDTA plasma (plastic tubes)	Serum and plasma
In vitro stability	24 h at room temperature	>3 d at room temperature

<sup>a</sup>FDA, Food and Drug Administration; NPR-C, natriuretic peptide receptor-C; NEP, neutral endopeptidase.

myocytes, recent data suggest that BNP can be produced by other cell types, including cardiac fibroblasts (58). Substantially increased ventricular levels of BNP mRNA in response to chronic cardiac overload have been observed in rat experimental models including spontaneously hypertensive rats (59,60) and coronary artery ligation (61), as well as in the human heart (62).

Table 4  
Characteristics of Natriuretic Peptide Production

<i>Characteristic</i>	<i>ANP</i>	<i>BNP</i>
Site (healthy state)	Atria	Atria and ventricles
Site (pressure/volume overload)	Atria and ventricles	Atria and ventricles
Gene expression	Constitutive	Inducible
Gene transcription response	Slow	Rapid
Granule storage pool	Large	Small
Release profile	Pulsatile	Pulsatile
Basal cardiac secretion rate	Moderate	Low
Relative increase in pressure/volume overload	Moderate	Large
Primary regulation of production	Secretion level	Synthesis level

BNP is commonly regarded to be a ventricular-derived hormone, but the concentration of BNP appears to be higher in atrial than in ventricular tissue. Taking into account tissue weight, however, the total amount of BNP mRNA has been suggested to be three times higher in the ventricle than in the atrium in an experimental rat model. Although the concentration of BNP is only 1% of that in the atrium, it has been estimated that 60% of secreted BNP is derived from the ventricle (60). In a rapid-pacing model of heart failure, the atrial myocardium was found to be the predominant site of BNP gene expression and production during the development of LV dysfunction (63). Catheterization studies in patients with LV hypertrophy have also suggested that atrium-derived BNP contributes significantly to the elevation in BNP, reflecting atrial pressure and volume in these patients (64). Thus, BNP should not be considered exclusively a ventricular-derived hormone, given that the predominant source of circulating BNP probably differs depending on both the severity and etiology of the cardiac disorder.

The predominant stimulus controlling the synthesis and release of BNP from cardiac atria (65) and ventricles (60) is wall stretch (Table 2). BNP expression and release from cardiomyocytes can also be stimulated by a variety of endocrine, paracrine, and autocrine factors that are activated in heart failure, including norepinephrine (66,67), angiotensin II (68), ET-1 (69), glucocorticoids, and proinflammatory cytokines (Table 2). For instance, blockade of angiotensin II type 1 (AT<sub>1</sub>) receptors or ET-1 type A (ET<sub>A</sub>) receptors suppressed stretch-induced BNP gene transcription by 50% in cultured neonatal ventricular cells (70). However, the AT<sub>1</sub> receptor antagonist losartan and the mixed ET<sub>A</sub>/ET<sub>B</sub> receptor antagonist bosentan had no effect on the acute pressure overload–induced increase in ventricular BNP mRNA in vivo (71), indicating that complex paracrine and autocrine mechanisms are involved in the regulation of BNP synthesis.

### ***Differences in Regulation of ANP and BNP Synthesis***

Although the main stimulus for synthesis and release appears to be the same for ANP and BNP, important aspects of the regulation and induction of peptide synthesis differ (Table 4). In experimental models, both atrial and ventricular BNP mRNA levels increase rapidly (<1 h) following acute pressure overload, and these changes are paralleled by increased circulating BNP (66). Similarly, activation of the BNP gene in the cardiac ventricles occurs rapidly after experimental myocardial infarction (MI) (61). By contrast, induction of the ANP gene occurs slowly (i.e., days) after the initiation of cardiac overload,

allowing storage in and pulsatile release of ANP from granules. These differences have implications for the kinetics of ANP and BNP release. The storage of ANP in secretory granules provides a source for rapid release of this peptide, whereas BNP release is generally thought to require a preceding increase in production of BNP mRNA. The stimulus required for increased release of BNP may therefore be stronger and of longer duration than the one required for the immediate release of stored ANP. Accordingly, acute iv saline loading and change in posture leading to an increase in atrial pressure result in a rapid increase in circulating ANP levels, whereas BNP levels remain unaltered (72,73). Conversely, in the course of a few days, dietary sodium loading increases circulating BNP levels (74). A rapid rise in BNP during provoked ischemia, however, suggests the existence of mechanisms for more rapid release in some settings.

### *C-Type Natriuretic Peptide*

CNP is a cyclic 22 amino acid polypeptide with primary structure homology with ANP and BNP without the carboxy-terminal tail of these peptides (Fig. 1). The gene encoding CNP is localized to human chromosome 2 and contains two exons separated by an intron (75). The gene encodes a 103 amino acid CNP precursor, proCNP (Table 1). proCNP is processed to generate 22 and 53 amino acid fragments (i.e., CNP-22 and CNP-53), the former sequence contained within the latter. CNP-22 is more potent and more widely distributed than CNP-53. In contrast to ANP and BNP, CNP is not expressed to an appreciable degree in cardiomyocytes but is primarily expressed in vascular endothelium and in the CNS (24,76). Within the heart, CNP is expressed in coronary endothelium and cardiac fibroblasts (77,78). Very low amounts of CNP are found circulating. CNP is believed to function as an autocrine and a paracrine factor participating in the regulation of vascular tone and cellular growth. CNP gene expression is stimulated by numerous cytokines, including tumor necrosis factor (TNF)- $\alpha$ , interleukin-1 $\alpha$ , and transforming growth factor- $\beta$  (77,79). Although systemic levels of CNP do not appear to increase notably in heart failure, a CNP concentration step-up from the aorta to the coronary sinus was recently reported, suggesting that myocardial CNP production may be increased in heart failure (80). Moreover, the amino-terminal fragment of proCNP is elevated in patients with symptomatic heart failure (81). Although the gene encoding CNP is abundantly expressed in the brain, its role and significance in the regulation of salt and water balance are poorly understood.

## NATRIURETIC PEPTIDE SIGNALING

Biological effects of the natriuretic peptides are mediated via binding to cell-surface-associated natriuretic peptide receptors (NPRs). Natriuretic peptides are endogenous ligands for three different NPRs—NPR-A, NPR-B, and NPR-C—all containing a single transmembrane domain and an extracellular binding domain (82–85). NPR-A and NPR-B seem to mediate most of the physiological actions of the natriuretic peptides, whereas NPR-C appears to function primarily as a clearance receptor and may modulate locally the physiological effect of the natriuretic peptides (86). Both NPR-A and NPR-B function as a particulate guanylyl cyclase, distinct from the cytosolic enzyme stimulated by nitric oxide.

### *Natriuretic Peptide Receptor-A and Natriuretic Peptide Receptor-B*

Both NPR-A and NPR-B are expressed widely in the cardiovascular system, including the cardiac atria and ventricles, aorta, and peripheral vasculature (87,88). In addition,

Table 5  
Relative Affinity of NPRs

<i>Receptor</i>	<i>Affinity</i>
NPR-A	ANP > BNP >> CNP
NPR-B	CNP >> ANP ⊕ BNP
NPR-C	ANP > CNP > BNP

NPR-A and NPR-B have been identified in lung, kidney, skin, platelets, and presynaptic sympathetic nerve fibers (89). NPR-A is the most abundant type of receptor in large blood vessels, whereas NPR-B predominates in the brain. Both ANP and BNP can bind with NPR-A with relatively high affinity, but BNP is approx 10-fold less potent than ANP (90) (Table 5). CNP appears to be ineffective in stimulating guanylyl cyclase in cells expressing NPR-A. By contrast, in cells expressing NPR-B, intracellular cyclic guanosine 5'-monophosphate (cGMP) concentration is increased only by CNP (75). High pharmacological concentrations of ANP and BNP are required to stimulate guanylyl cyclase activity in cells expressing NPR-B.

NPR-A has a large extracellular ligand-binding domain connected to an intracellular domain by a single membrane-spanning hydrophobic segment (91,92). The N-terminal region of the intracellular portion of the receptor contains a kinase-like domain, which binds adenosine triphosphate (ATP) but lacks true kinase activity. The kinase-like domain may participate in the regulation of receptor activity. The guanylyl cyclase domain occupies the C-terminal portion of the receptor molecule. Ligand binding is believed to induce a conformational change in the receptor molecule, leading to guanylyl cyclase activation and subsequent increased intracellular production of cGMP. The structural topography of NPR-B resembles that of NPR-A, and it also signals through a guanylyl cyclase mechanism (91). As mentioned, NPR-B has high affinity for CNP and limited affinity for ANP and BNP.

### *Natriuretic Peptide Receptor-C*

NPR-C, or clearance receptor, is structurally distinct from NPR-A and NPR-B. Similar to NPR-A and NPR-B, NPR-C has a large extracellular domain and a membrane-spanning segment. The extracellular domain shares approx 30% primary structure homology with NPR-A and NPR-B. In contrast to the two other receptors, NPR-C is devoid of guanylyl cyclase activity, and the cytoplasmic domain contains only a 37 amino acid tail at the C-terminus having no sequence homology with any known receptor. The truncated intracellular domain and the absence of guanylyl cyclase activity suggest that NPR-C may function by removing natriuretic peptides from the extracellular compartment (93). Some evidence indicates that NPR-C may also have a signaling function by inhibiting adenylyl cyclase through a G<sub>i</sub>-dependent mechanism (94), but a physiological role beyond its function as a clearance receptor remains to be demonstrated in vivo (95). NPR-C is the most abundantly distributed natriuretic peptide receptor and has been identified in several tissues, including vascular endothelium, smooth muscle, adipose tissue, cardiac muscle, adrenal gland, kidney, and brain (96). All natriuretic peptides associate with NPR-C with high affinity (Table 5). However, the affinity for ANP and CNP appears to be somewhat higher than for BNP (97), which may contribute to the longer plasma half-life of BNP compared with ANP. The ring structure of the natriuretic peptides, formed by a disulfide bridge between

two cysteine residues, appears to be a requirement for binding to the NPRs. Accordingly, hydrolytic disruption of this bridge leads to loss of biological activity. The circulating N-terminal fragments of the natriuretic peptide prohormones are devoid of disulfide bonds and do not appear to exert physiological actions through binding to NPRs.

### *Signal Transduction*

Natriuretic peptide-induced cellular responses occur principally as a result of increased intracellular concentrations of cGMP. Accordingly, in all cell types expressing NPR-A or NPR-B, exposure of natriuretic peptides results in elevated intracellular cGMP levels, and the specific cellular responses depend on downstream targeting and degradation of cGMP. A cGMP-dependent protein kinase (protein kinase G [PKG]) is believed to be the primary intracellular mediator of cGMP signals (98). Elevation of intracellular cGMP induced by natriuretic peptides results in activation of PKG leading to catalytic transfer of phosphate from ATP to serine or threonine residues of target proteins. The phosphorylated proteins determine the translation of the extracellular stimulus into a specific biological function. PKGs can activate numerous substrate proteins. Cyclic nucleotide-gated ion channels regulating transmembrane fluxes of Na<sup>+</sup> and Ca<sup>2+</sup> may be of particular relevance to the physiological actions of natriuretic peptides. Natriuretic peptide-induced increase in intracellular cGMP concentration may also cause activation of phosphodiesterase II, an enzyme crucial for cellular signaling through its modulatory effect on intracellular levels of cyclic nucleotides.

## CLEARANCE OF NATRIURETIC PEPTIDES

### *Mechanisms of Natriuretic Peptide Clearance*

Clearance of natriuretic peptides from the circulation involves two main pathways: (1) NPR-C-mediated endocytosis followed by lysosomal degradation and (2) enzymatic degradation independent of the clearance receptor by the enzyme neutral endopeptidase (NEP) (99,100). NEP is a zinc metallopeptidase widely distributed on the surface of endothelial cells, vascular smooth muscle cells (VSMCs), cardiac myocytes, and fibroblasts (101). The lungs, liver, and kidneys are the most important organs for natriuretic peptide clearance. In the kidneys, NEP is particularly abundantly expressed at the brush-border membranes of proximal tubule cells. Inactivation of the peptides by NEP is believed to involve proteolytic cleavage of the peptides as well as disruption of the disulfide bond.

The relative contribution of receptor-mediated vs NEP-mediated clearance is controversial. Some animal experiments have suggested that for clearance of ANP, NPR-C blockade is of greater importance than NEP inhibitors. By contrast, studies in sheep have shown that proteolytic and receptor-mediated pathways contribute equally to ANP and BNP elimination from the circulation (102). In a sheep model of heart failure, the enzymatic and receptor clearance pathways appear to contribute equally to the metabolism of ANP and BNP (103). The relative contribution of receptor-mediated vs enzyme-mediated clearance in humans is less well defined. Early indirect evidence following ANP infusion in patients with heart failure suggested that receptor clearance of BNP was of less importance than enzyme degradation (57). Experiments with purified human NEP have indicated that a relative resistance to NEP is responsible for the delayed metabolism of BNP compared with ANP (104).

A third potential mechanism involved in the elimination of natriuretic peptides is renal clearance. Plasma levels of ANP and BNP, as well as NT-proANP and NT-proBNP, are

all increased in renal failure. Raised levels in renal failure may be owing to a combination of factors, including volume overload, intrinsic heart disease, and decreased renal clearance. Inverse correlations between the glomerular filtration rate (GFR) and circulating levels of natriuretic peptides have also been observed in subjects without renal failure, suggesting that renal elimination may play a role (105). Correlations have tended to be somewhat closer between the inactive N-terminal fragments and GFR than between the biologically active C-terminal fragments, ANP and BNP, but comparative data from the same subjects are scarce. Although natriuretic peptides and N-terminal prohormone fragments can be identified and measured in urine, levels are very low (106), suggesting that renal filtration is not a major pathway for natriuretic peptide degradation.

Adipose tissue may also contribute to the clearance of natriuretic peptides. An inverse relation between plasma levels of BNP and body mass index (BMI) has been observed both in patients with heart failure (107) and in subjects without heart failure (108). Although the exact mechanism remains to be elucidated, it is well known that NPR-C is abundant in adipose tissue (109), suggesting that adipocytes participate in the removal of natriuretic peptides from the circulation. In experimental models, caloric deprivation is associated with decreased NPR-C gene expression and increased ANP plasma levels (110,111).

### ***Plasma Half-Lives of N-Terminal and C-Terminal Natriuretic Peptides***

Although the N- and C-terminal fragments of proANP and proBNP are secreted in a 1:1 fashion, circulating levels may differ because of different clearance characteristics. Accordingly, the in vivo plasma half-life of NT-proANP is much longer than that of ANP (slow component of 55 vs 13 min in the rat) (112), and the circulating concentrations in humans are correspondingly higher (113). The observation that circulating concentrations of NT-proBNP exceed those of BNP is also suggestive of a slower clearance rate for NT-proBNP than for BNP (53,54). The in vivo plasma half-life of BNP has been estimated to be approx 21 min (4,114). Studies in humans have yet to be performed to estimate the circulating half-life of NT-proBNP, but investigations indicate that in sheep the half-life may be as long as 70 min (115). The plasma half-life of CNP in sheep has been estimated to be approx 3 min (116).

## **PHYSIOLOGICAL ACTIONS OF NATRIURETIC PEPTIDES**

### ***Vascular Actions***

Natriuretic peptides cause relaxation of vascular smooth muscle (Table 6). In animal experiments, sustained infusion of ANP and BNP reduces peripheral vascular resistance and lowers blood pressure (BP) (117). In humans, ANP infusion causes arterial and venous dilatation, leading to reduced arterial BP and ventricular preload (118,119). CNP appears to be a more potent venodilator than ANP and BNP (2,120). Cardiac preload may also be reduced by a shift of fluid from the intravascular to the extravascular compartment (121,122). This shift may be caused by natriuretic peptide-induced increased permeability of the vascular endothelium, and possibly increased hydraulic pressure in the capillary bed.

### ***Neurohormonal Actions***

Important actions of the natriuretic peptides are mediated via interaction with other neurohormonal axes (Table 6). For instance, the inhibitory effects of natriuretic peptides on the renin–angiotensin–aldosterone axis will act synergistically with the direct natriuretic and diuretic effects and cause subsequent decrease in extracellular fluid, ventricular preload,

**Table 6**  
**Physiological Actions of Natriuretic Peptides**

<i>Target organ</i>	<i>Physiological action</i>
Heart	Antifibrotic (BNP, CNP) Antihypertrophic (ANP)
Blood vessels	Arterial and venous vasorelaxation Inhibition of VSMC mitogenesis Proliferation of endothelial cells (CNP) Fluid extravasation from splenic vasculature into lymphatic vessels Elevated capillary hydraulic conductivity
Kidney	Increased glomerular filtration (ANP) Natriuresis Diuresis Inhibition of renin release
Endocrine	Neurohormonal suppression: Inhibition of renin–angiotensin–aldosterone system Inhibition of SNS Inhibition of arginine vasopressin Inhibition of ET
Metabolic	Lipolysis
CNS	Inhibition of thirst and salt appetite Inhibition of sympathetic outflow Inhibition of arginine vasopressin

and arterial BP (*121*). Natriuretic peptides directly inhibit renin release, and aldosterone production is decreased both directly and indirectly by inhibition of the stimulatory effects of angiotensin II on the release of aldosterone (*123, 124*). Natriuretic peptides also inhibit production of ET-1 (*125*). Inhibitory effects of ANP and BNP on central sympathetic outflow and on catecholamine release from peripheral sympathetic neurons may contribute importantly to the systemic vasodepressant actions of these peptides (*14, 126, 127*). Natriuretic peptides also lower the activation threshold of vagal afferents, suppressing the reflex tachycardia and vasoconstriction that normally accompany preload reduction (*2*).

### *Effects on Cardiac Contractility*

Natriuretic peptides may also have direct effects on the myocardium. In a variety of experimental preparations, ANP, BNP, and CNP have been reported to affect cardiac contractility, but the results are conflicting. Although some studies have suggested negative inotropic effects of natriuretic peptides (*128*), these effects are unlikely to be clinically relevant. In healthy humans, BNP affects LV filling patterns by an apparent lusitropic effect (*129*).

### *Antiproliferative Actions*

Activation of proliferative signaling pathways is a hallmark of many cardiovascular disease (CVD) states, including atherosclerosis, vascular remodeling following percutaneous coronary intervention (PCI), hypertensive heart disease, and ventricular remodeling and dilatation following MI. For example, cardiomyocyte hypertrophy with accumulation of extracellular matrix (ECM) proteins in the surviving part of the myocardium is characteristic of postinfarction remodeling. A long line of evidence suggests that ANP, BNP, and CNP modulate cell growth, apoptosis, and proliferation in VSMCs and cardiomyocytes



Table 7  
Effects of Genetic Alterations of Natriuretic Peptides and Their Receptors

<i>Genetic alteration</i>	<i>Phenotype</i>	<i>References</i>
ANP deletion	Salt-sensitive hypertension, pulmonary hypertension	175
BNP deletion	Cardiac fibrosis	134
CNP deletion	Altered endochondral ossification, dwarfism	219
ANP overexpression	Arterial hypotension	173
BNP overexpression	Arterial hypotension, skeletal overgrowth	174,220
NPR-A deletion	Cardiac hypertrophy and fibrosis, sudden death, salt-resistant hypertension	132,135,176
NPR-A overexpression	Arterial hypotension	221
NPR-C deletion	Hypotension, diuresis, reduced ability to concentrate urine, volume depletion, skeletal deformities	86

(130–132) (Table 6). Moreover, ANP and BNP may suppress cardiac fibroblast proliferation and secretion of ECM (58). Somewhat surprisingly, studies of animals with engineered deletion of the genes encoding preproANP and preproBNP have revealed striking differences within the strains (Table 7). Whereas ANP-deficient mice develop salt-sensitive hypertension with ventricular hypertrophy (133), BNP-deficient mice develop cardiac fibrosis but not hypertension or hypertrophy (134). Moreover, mice with disruption of the gene encoding the common receptor for ANP and BNP, NPR-A, develop salt-resistant hypertension, ventricular hypertrophy, and fibrosis (135) (Table 7). These findings suggest complementary roles for ANP and BNP in the regulation and modulation of cardiac structure and function.

CNP may also possess antimitogenic actions in the cardiovascular system, with a possible role in the development of atherosclerosis (136,137) (Table 6). For instance, in cell culture experiments, endothelium-derived CNP has been shown to have growth-inhibitory effects on VSMCs (138), and in experimental models, CNP has been shown to inhibit intimal thickening after vascular injury induced by balloon inflation in the rat carotid artery (139). CNP immunoreactivity has also been identified in atherosclerotic lesions (140). In addition, an inhibitory effect of CNP on cultured cardiomyocyte hypertrophy has been demonstrated, suggesting that overexpression of CNP in the heart may play a role in modulating cardiac remodeling during the development of heart failure (141).

### **Renal Actions**

The natriuretic peptides exert potent natriuretic and diuretic effects in the kidneys (Table 6). Both renal hemodynamics and tubular reabsorption are affected. Glomerular filtration is increased by ANP as a consequence of elevated pressure within the glomerular capillaries secondary to a combination of afferent arteriolar dilatation and efferent arteriolar constriction (142). By contrast, BNP does not appear to increase glomerular filtration (143). Natriuretic peptide-induced mesangial cell relaxation may increase the effective glomerular filtration area and thereby contribute to an augmented filtration fraction (144). In addition to the glomerular effects, natriuretic peptides exert direct renal tubular actions. Accordingly, in the proximal convoluted tubules, ANP antagonizes angiotensin II-induced sodium and water reabsorption (145), in the cortical collecting ducts the effect of vasopressin is inhibited (146), and in the medullary collecting ducts sodium reabsorption is reduced (147). Administration of a relatively specific bacterial-derived polysaccharide

Table 8

**Clinical Conditions and Demographic Factors Associated With Elevated BNP Concentrations**

- Acute and chronic CHF
- Acute and chronic right heart failure (e.g., large pulmonary embolus, cor pulmonale)
- Acute and chronic renal failure
- AMI
- Unstable angina
- Advanced age
- Female gender
- Hypertensive heart disease
- Diabetes mellitus
- Low BMI

inhibitor of NPR-A and NPR-B, HS 142-1, results in increased renal vascular resistance; increased circulating renin, aldosterone, and catecholamine levels; and inhibition of natriuretic peptide-induced natriuresis and diuresis (148). CNP, in contrast to ANP and BNP, seems to lack a significant natriuretic effect (149).

The renal actions of natriuretic peptides may be exerted in both an endocrine and a paracrine/autocrine fashion. Infusion of natriuretic peptides at physiological doses causes diuresis and natriuresis without affecting hemodynamics in humans and inhibition of the renin–angiotensin–aldosterone system (150). Urodilatin, a product of alternative processing of proANP in the distal tubules of the kidney, is believed to act in a paracrine/autocrine fashion and may have greater potency in the kidneys than ANP and BNP.

**CNS Actions**

ANP, BNP, and CNP are all synthesized in the brain. In the CNS, the natriuretic peptides' actions are synergistic with their peripheral effects on the cardiovascular system, on the neurohormonal system, and in the kidneys (Table 6). In the brain, natriuretic peptides inhibit thirst and salt appetite via an NPR-A-mediated mechanism, thereby complementing the diuretic and natriuretic effects in the kidneys (2). Moreover, vasopressin secretion from the pituitary is inhibited via CNP binding to NPR-B. The peripheral sympathoinhibitory effects of natriuretic peptides are complemented by central inhibition of sympathetic tone (127). Similar to what is observed in the periphery, other neurohormonal substances, including norepinephrine, ET, and vasopressin, stimulate the release of ANP from cultured hypothalamic neurons (2).

**NATRIURETIC PEPTIDES IN CVDs**

The natriuretic peptide system is activated in a broad spectrum of CVDs, including systolic and diastolic LV dysfunction, acute coronary syndromes, stable coronary heart disease, valvular heart disease, acute and chronic right ventricular failure, and left and right ventricular hypertrophy secondary to arterial or pulmonary hypertension (Table 8). These conditions are, to a varying extent, characterized by neurohormonal and immune activation. The activation of vasoconstrictor, antidiuretic, proinflammatory, hypertrophic, and cytoproliferative systems, including the sympathetic nervous system (SNS), renin–angiotensin–aldosterone system, arginine vasopressin, and ET, is believed to play a pathophysiological role in the progression of many of these conditions (151). A prime example is the progressive LV hypertrophy, remodeling, and dilatation that occur in parallel with the

clinical progression from asymptomatic LV dysfunction to overt congestive heart failure (CHF), a process that is significantly retarded by neurohormonal blockade. Counteracting the vasoconstrictor neurohormonal systems, the natriuretic peptides possess beneficial and compensatory properties that are of clinical importance. The pathophysiological role that the natriuretic peptides play is probably best defined in CHF.

### *Congestive Heart Failure*

Circulating levels of ANP and BNP and the amino-terminal fragments NT-proANP and NT-proBNP of their prohormones (proANP and proBNP) are elevated in CHF. The concentrations are related to the severity of symptoms (36,152,153), the degree of LV dysfunction (154), and cardiac filling pressures (4,35,155). Very high circulating levels can be found in patients with severe, untreated CHF (156) or during episodes of acute decompensation (157). Both systolic and diastolic impairment of the left ventricle can result in elevated circulating natriuretic peptide levels (158,159). However, circulating levels of these peptides are elevated even in mildly symptomatic or asymptomatic patients with LV impairment (155,160,161).

Stretching of the atrial and failing ventricular myocardium secondary to volume overload is a potent stimulus for ANP and BNP gene expression and release and probably outweighs the influence of other modulating factors of natriuretic peptide production (34,60,62). Several other mechanisms also contribute to elevated circulating levels of natriuretic peptides in heart failure. Cardiac hypertrophy *per se* is a potent stimulus for ANP and BNP production (64). The increased muscle mass associated with LV hypertrophy will also contribute to increased production and subsequent elevation of plasma natriuretic peptides. In patients with an old myocardial infarction, secretion of BNP is much greater from the infarcted region than from the noninfarcted region, suggesting that regional ventricular wall stretch caused by the old infarct strongly stimulates secretion of BNP (162). Vasoconstrictor neurohormones stimulate natriuretic peptide production. Renal impairment, a condition commonly associated with cardiac impairment, will result in decreased clearance of natriuretic peptides (163).

Natriuretic peptides have beneficial actions in heart failure. The natriuretic, diuretic, and vasodilatory effects tend to decrease cardiac preload and afterload. In addition, inhibition of the renin–angiotensin system and SNS will act synergistically with the direct hemodynamic and renal effects. The significance of the inhibitory actions of the natriuretic peptide system on the renin–angiotensin system is illustrated by the effect of NPR-A blockade. In a canine experimental model of early LV dysfunction, NPR-A blockade with the receptor antagonist HS-142-1 resulted in sodium retention, augmented renin release, increased aldosterone production, and accelerated progression to overt heart failure (148,164). Bilateral atrial appendectomies had a similar effect (164). In an experimental model of canine heart failure, coinfusion of BNP and furosemide resulted in a more profound diuretic and natriuretic response than furosemide alone (165). Moreover, during coinfusion, glomerular filtration was increased while renal function was preserved and aldosterone activation was inhibited. As mentioned in Table 7, BNP and NPR-A receptor gene knock-out (KO) models are associated with cardiac fibrosis (134) and hypertension, cardiac hypertrophy, and sudden death (135), respectively. These findings are suggestive of an important role for natriuretic peptides for the maintenance of cardiovascular homeostasis.

Based on theoretical considerations and observations made in experimental models, drugs that increase circulating levels of natriuretic peptides have been developed for use

in human heart failure. Two strategies have reached late-stage clinical development: administration of exogenous recombinant BNP (nesiritide) and potentiation of endogenous effects of natriuretic peptides by inhibition of NEP (166). Nesiritide infusion has beneficial effects in human heart failure, including a dose-dependent decrease in pulmonary capillary wedge pressure, improved cardiac index, and augmented urinary flow (167–169). Subcutaneous administration of BNP has also been shown to represent an efficacious strategy in human heart failure (170).

Combined NEP inhibition and ACE inhibition by vasopeptidase inhibitors such as omapatrilat result in greater hemodynamic and renal effects than with selective inhibition of either of these enzymes (166). In early studies in heart failure, omapatrilat caused a dose-dependent reduction in BP and pulmonary capillary wedge pressure, improvement in cardiac output, and lowering of circulating norepinephrine concentrations (171). These beneficial effects did not, however, translate into reduced survival in a large-scale phase III clinical trial (172).

### *Hypertension*

Natriuretic peptides appear to play an important role in preventing the development of arterial and pulmonary hypertension. Overexpression of the genes encoding ANP and BNP results in raised circulating concentrations of these peptides and substantially decreased arterial BP (173,174). Moreover, overexpression of ANP protects against the development of pulmonary hypertension in animals exposed to chronic hypoxia. Conversely, ANP gene KO mice are prone to develop salt-sensitive arterial hypertension and pulmonary hypertension with accompanying right ventricular hypertrophy (175). The ability of ANP to defend against salt-induced arterial hypertension may reflect a combination of the natriuretic, diuretic, vasorelaxant, and sympathoinhibitory properties of this peptide. The NPR-A gene KO mice phenotype is also characterized by arterial hypertension, which appears to be independent of sodium loading (176). Genetic disruption of NPR-A is also associated with a marked cardiac hypertrophy that is disproportionate to the increase in BP and is resistant to antihypertensive medication (132,177). To distinguish further between systemic hemodynamic and local effects of natriuretic peptides, mice with selective deletion of the gene encoding NPR-A in cardiomyocytes have been generated (131). In these animals, cardiac hypertrophic responses to aortic constriction were enhanced and accompanied by marked deterioration of cardiac function (131). Taken together with data from past studies, these data represent convincing evidence that ANP and BNP induced NPR-A signaling function as a myocyte intrinsic counterregulatory growth circuit in the heart.

Whether mutations of the natriuretic peptides or their receptors are related to human hypertension and ventricular hypertrophy is less well defined. Theoretically, interindividual variability in circulating natriuretic peptide levels may be related to genetic influences, which, in turn, may be associated with differential susceptibility to development of hypertension and ventricular hypertrophy. Data from the Framingham Heart Study suggest that a substantial proportion of the variation in natriuretic peptide levels not explained by conventional predictors was attributable to additive genetic effects (178). Other studies have suggested that variants of the gene encoding ANP in humans may exert protective effects against the development and progression of kidney damage in the general population and in patients with type 2 diabetes independently of hypertension (179,180). Polymorphisms in the gene encoding CNP have been associated with essential hypertension (181).

### ***Valvular Heart Disease***

Aortic stenosis is associated with LV hypertrophy and LV relaxation abnormalities and may, in some cases, eventually progress to LV systolic dysfunction. The progression of aortic stenosis is routinely monitored by serial Doppler echocardiographic examinations, permitting noninvasive estimates of the transvalvular gradient and aortic valve orifice area. The relation among natriuretic peptide plasma levels, disease severity, and symptoms has been examined in patients with aortic stenosis (182–184). BNP and NT-proBNP plasma levels were higher in symptomatic than in asymptomatic patients, even after adjustment for aortic valve area and ventricular function (184). NT-proBNP was found to be a sensitive marker of even mild LV hypertrophy (183) and to correlate significantly with the transvalvular pressure gradient (182).

Mitral regurgitation, secondary to LV dilatation, is common in patients with chronic heart failure. Moreover, mitral regurgitation is commonly associated with increased left atrial pressure. Given the associations with LV volumes and atrial pressure, it is not surprising that in patients with LV dysfunction, the severity of mitral regurgitation is associated with circulating BNP and NT-proBNP levels (185).

### ***Acute Myocardial Infarction***

The cardiac natriuretic peptide system is rapidly activated following acute ischemic injury, as evidenced by elevated circulating and tissue concentrations (61,186–189). Augmented production of cardiac natriuretic peptides in the early phase after MI may be caused by a variety of factors. Myocardial stretch secondary to LV dysfunction may be of greatest importance, but increased heart rate, hypoxia, and ischemia *per se*; the stimulatory effects of catecholamines, angiotensin II, and ETs; as well as decreased clearance may contribute. Plasma concentrations of natriuretic peptides are increased in acute MI in proportion to the degree of LV dysfunction (190). A strong relation between plasma levels of natriuretic peptides obtained in the subacute phase, and long-term, all-cause mortality, as well as the rate of readmissions for heart failure after MI has been convincingly demonstrated (190–193).

### ***Myocardial Ischemia***

Myocardial ischemia can induce a reversible increase in regional wall stress that may lead to augmented natriuretic peptide release. Supporting this possibility is the observation that natriuretic peptide levels are increased in patients with stable coronary artery disease (CAD) after episodes of ischemia. Elevated BNP and NT-proBNP levels have also been observed in patients with unstable angina (194,195), and during and after PCI (196,197). In patients with angiographically documented CAD, the rise in BNP concentration is proportional to the size of the reversible perfusion defect (198). In patients with normal LV systolic function undergoing coronary bypass surgery, circulating BNP levels are increased and correlate with BNP mRNA expression (199). Patients with signs of exercise-induced ischemia by dobutamine stress echocardiography have been reported to have higher baseline BNP values (200).

In experimental models, BNP production and release are rapidly increased after the induction of myocardial ischemia. For instance, in a Langendorff preparation, the release of both ANP and BNP was augmented after perfusion with a hypoxic solution (46). BNP gene expression is induced rapidly following experimental MI (61). Recent studies suggest that the augmented release of BNP following brief periods of ischemia occurs with-

out concomitant change in LV end diastolic pressure, suggesting that ischemia *per se* is the stimulus for BNP release (201). These observations have raised the possibility that early activation of natriuretic peptides, by exerting cytoprotective actions, may represent an important physiological response to myocardial ischemia (202).

### ***Diabetes Mellitus***

Patients with diabetes have an increased incidence of CHD, hypertension, and heart failure (203,204), which is in part induced by the metabolic and structural changes seen in the diabetic heart. The diabetes-induced structural changes in the myocardium consist of increased fibrosis and increased ventricular mass (205,206), conditions that together with the more aggressive atherosclerosis may explain the higher cardiac morbidity and mortality in patients with diabetes. Both type 1 and 2 diabetes have been associated with increased levels of natriuretic peptides (207–210). Contrasting population-based data suggest that diabetes is associated with lower natriuretic peptide concentration (108), independent of the effect of obesity (108). However, in experimental animal models, diabetes increases the expression of cardiac BNP (211) and prevents myocardial growth via a cGMP-dependent mechanism (212). In humans, acute (i.e., lasting for hours) hyperinsulinemia causes an increase in ANP, but not of BNP (213). The chronic effects of hyperinsulinemia on natriuretic peptide levels remain to be elucidated. It has been shown that measurement of BNP can reliably identify diabetic patients with LV dysfunction independent of symptoms of heart failure (214) and may be useful in the clinical setting to identify patients with diabetes who warrant further cardiac examination (215).

### ***Influence of Age and Gender***

Several noncardiac factors may influence the circulating levels of natriuretic peptides and potentially confound the relation to indices of cardiac function. Age has been shown to be an important determinant of circulating natriuretic peptide levels (216–218). Both increased release and decreased clearance may contribute to elevated circulating levels of BNP and NT-proBNP in advanced age, but the exact mechanisms remain to be elucidated. Subclinical reduction in renal function, increased LV mass, and LV diastolic dysfunction are factors that may be essential for the observed increments in BNP and NT-proBNP levels with age. Population-based studies have convincingly shown that BNP and NT-proBNP levels not only increase with age but are also significantly higher in women than in men (216–218). The association between female gender and BNP may be owing to estrogen status, because BNP levels were found to be higher in women using hormone replacement therapy (217).

## **CONCLUSION**

Since the discovery of ANP almost 25 yr ago, remarkable progress has been made in the field of natriuretic peptide research. The role that natriuretic peptides play in cardiovascular homeostasis in health and disease has been the subject of intense study, and current natriuretic peptide research spans from basic molecular biology and genetics to clinical trials. This research has documented that natriuretic peptides play a central role in cardiovascular homeostasis and exert pleiotropic autocrine and paracrine effects far beyond the classic natriuretic and vasorelaxant effects originally described for ANP. Future research concerning the biology of the natriuretic peptides will likely lead to discoveries that may translate into new advances in clinical medicine.

## REFERENCES

1. Wilkins MR, Redondo J, Brown LA. The natriuretic-peptide family. *Lancet* 1997;349(9061):1307–1310.
2. Levin ER, Gardner DG, Samson WK. Natriuretic peptides. *N Engl J Med* 1998;339(5):321–328.
3. Sugawara A, Nakao K, Morii N, et al. Alpha-human atrial natriuretic polypeptide is released from the heart and circulates in the body. *Biochem Biophys Res Commun* 1985;129(2):439–446.
4. Mukoyama M, Nakao K, Hosoda K, et al. Brain natriuretic peptide as a novel cardiac hormone in humans: evidence for an exquisite dual natriuretic peptide system, atrial natriuretic peptide and brain natriuretic peptide. *J Clin Invest* 1991;87(4):1402–1412.
5. Minamino N, Makino Y, Tateyama H, Kangawa K, Matsuo H. Characterization of immunoreactive human C-type natriuretic peptide in brain and heart. *Biochem Biophys Res Commun* 1991;179(1):535–542.
6. Schweitz H, Vigne P, Moinier D, Frelin C, Lazdunski M. A new member of the natriuretic peptide family is present in the venom of the green mamba (*Dendroaspis angusticeps*). *J Biol Chem* 1992;267(20):13,928–13,932.
7. Schirger JA, Heublein DM, Chen HH, et al. Presence of *Dendroaspis* natriuretic peptide-like immunoreactivity in human plasma and its increase during human heart failure. *Mayo Clin Proc* 1999;74(2):126–130.
8. Gunning M, Brenner BM. Urodilatin: a potent natriuretic peptide of renal origin. *Curr Opin Nephrol Hypertens* 1993;2(6):857–862.
9. Forte LR, Currie MG. Guanylin: a peptide regulator of epithelial transport. *FASEB J* 1995;9(8):643–650.
10. Forte LR, London RM, Freeman RH, Krause WJ. Guanylin peptides: renal actions mediated by cyclic GMP. *Am J Physiol Renal Physiol* 2000;278(2):F180–F191.
11. Hamra FK, Forte LR, Eber SL, et al. Uroguanylin: structure and activity of a second endogenous peptide that stimulates intestinal guanylate cyclase. *Proc Natl Acad Sci USA* 1993;90(22):10,464–10,468.
12. Schirger JA, Grantham JA, Kullo IJ, et al. Vascular actions of brain natriuretic peptide: modulation by atherosclerosis and neutral endopeptidase inhibition. *J Am Coll Cardiol* 2000;35(3):796–801.
13. Ogawa Y, Tamura N, Chusho H, Nakao K. Brain natriuretic peptide appears to act locally as an anti-fibrotic factor in the heart. *Can J Physiol Pharmacol* 2001;79(8):723–729.
14. Brunner-La Rocca HP, Kaye DM, Woods RL, Hastings J, Esler MD. Effects of intravenous brain natriuretic peptide on regional sympathetic activity in patients with chronic heart failure as compared with healthy control subjects. *J Am Coll Cardiol* 2001;37(5):1221–1227.
15. Kisch B. Electron microscopy of the atrium of the heart. I. Guinea pig. *Exp Med Surg* 1956;14(2–3):99–112.
16. Jamieson JD, Palade GE. Specific granules in atrial muscle cells. *J Cell Biol* 1964;23:151–172.
17. Henry JP, Pearce JW. The possible role of cardiac atrial stretch receptors in the induction of changes in urine flow. *J Physiol* 1956;131(3):572–585.
18. Henry JP, Gauer OH, Reeves JL. Evidence of the atrial location of receptors influencing urine flow. *Circ Res* 1956;4(1):85–90.
19. De Bold AJ. Heart atria granularity effects of changes in water-electrolyte balance. *Proc Soc Exp Biol Med* 1979;161(4):508–511.
20. De Bold AJ, Borenstein HB, Veress AT, Sonnenberg H. A rapid and potent natriuretic response to intravenous injection of atrial myocardial extract in rats. *Life Sci* 1981;28(1):89–94.
21. Atlas SA, Kleinert HD, Camargo MJ, et al. Purification, sequencing and synthesis of natriuretic and vasoactive rat atrial peptide. *Nature* 1984;309(5970):717–719.
22. Kangawa K, Matsuo H. Purification and complete amino acid sequence of alpha-human atrial natriuretic polypeptide (alpha-hANP). *Biochem Biophys Res Commun* 1984;118(1):131–139.
23. Sudoh T, Kangawa K, Minamino N, Matsuo H. A new natriuretic peptide in porcine brain. *Nature* 1988;332(6159):78–81.
24. Sudoh T, Minamino N, Kangawa K, Matsuo H. C-type natriuretic peptide (CNP): a new member of natriuretic peptide family identified in porcine brain. *Biochem Biophys Res Commun* 1990;168(2):863–870.
25. Oikawa S, Imai M, Ueno A, et al. Cloning and sequence analysis of cDNA encoding a precursor for human atrial natriuretic polypeptide. *Nature* 1984;309(5970):724–726.
26. Yandle TG. Biochemistry of natriuretic peptides. *J Intern Med* 1994;235(6):561–576.
27. Wu F, Yan W, Pan J, Morser J, Wu Q. Processing of pro-atrial natriuretic peptide by corin in cardiac myocytes. *J Biol Chem* 2002;277(19):16,900–16,905.

28. Buckley MG, Sagnella GA, Markandu ND, Singer DR, MacGregor GA. Concentrations of N-terminal ProANP in human plasma: evidence for ProANP (1-98) as the circulating form. *Clin Chim Acta* 1990; 191(1-2):1-14.
29. Vesely DL, Douglass MA, Dietz JR, et al. Three peptides from the atrial natriuretic factor prohormone amino terminus lower blood pressure and produce diuresis, natriuresis, and/or kaliuresis in humans. *Circulation* 1994;90(3):1129-1140.
30. Cameron VA, Aitken GD, Ellmers LJ, Kennedy MA, Espiner EA. The sites of gene expression of atrial, brain, and C-type natriuretic peptides in mouse fetal development: temporal changes in embryos and placenta. *Endocrinology* 1996;137(3):817-824.
31. Mercadier JJ, Zongazo MA, Wisniewsky C, et al. Atrial natriuretic factor messenger ribonucleic acid and peptide in the human heart during ontogenic development. *Biochem Biophys Res Commun* 1989;159(2):777-782.
32. Gu J, D'Andrea M, Seethapathy M. Atrial natriuretic peptide and its messenger ribonucleic acid in overloaded and overload-released ventricles of rat. *Endocrinology* 1989;125(4):2066-2074.
33. Edwards BS, Zimmerman RS, Schwab TR, Heublein DM, Burnett JC Jr. Atrial stretch, not pressure, is the principal determinant controlling the acute release of atrial natriuretic factor. *Circ Res* 1988;62(2): 191-195.
34. Lang RE, Tholken H, Ganten D, Luft FC, Ruskoaho H, Unger T. Atrial natriuretic factor—a circulating hormone stimulated by volume loading. *Nature* 1985;314(6008):264-266.
35. Raine AE, Erne P, Burgisser E, et al. Atrial natriuretic peptide and atrial pressure in patients with congestive heart failure. *N Engl J Med* 1986;315(9):533-537.
36. Burnett JC Jr, Kao PC, Hu DC, et al. Atrial natriuretic peptide elevation in congestive heart failure in the human. *Science* 1986;231(4742):1145-1147.
37. Ruskoaho H. Cardiac hormones as diagnostic tools in heart failure. *Endocr Rev* 2003;24(3):341-356.
38. Kinnunen P, Vuolteenaho O, Uusimaa P, Ruskoaho H. Passive mechanical stretch releases atrial natriuretic peptide from rat ventricular myocardium. *Circ Res* 1992;70(6):1244-1253.
39. Yasue H, Obata K, Okumura K, et al. Increased secretion of atrial natriuretic polypeptide from the left ventricle in patients with dilated cardiomyopathy. *J Clin Invest* 1989;83(1):46-51.
40. Thibault G, Nemer M, Drouin J, et al. Ventricles as a major site of atrial natriuretic factor synthesis and release in cardiomyopathic hamsters with heart failure. *Circ Res* 1989;65(1):71-82.
41. Ruskoaho H. Atrial natriuretic peptide: synthesis, release, and metabolism. *Pharmacol Rev* 1992;44(4): 479-602.
42. Wiese S, Breyer T, Dragu A, et al. Gene expression of brain natriuretic peptide in isolated atrial and ventricular human myocardium: influence of angiotensin II and diastolic fiber length. *Circulation* 2000; 102(25):3074-3079.
43. Bruneau BG, Piazza LA, De Bold AJ. BNP gene expression is specifically modulated by stretch and ET-1 in a new model of isolated rat atria. *Am J Physiol* 1997;273(6 Pt 2):H2678-H2686.
44. Nishimori T, Tsujino M, Sato K, Imai T, Marumo F, Hirata Y. Dexamethasone-induced up-regulation of adrenomedullin and atrial natriuretic peptide genes in cultured rat ventricular myocytes. *J Mol Cell Cardiol* 1997;29(8):2125-2130.
45. De Bold AJ, Bruneau BG, Kuroski de Bold ML. Mechanical and neuroendocrine regulation of the endocrine heart. *Cardiovasc Res* 1996;31(1):7-18.
46. Toth M, Vuorinen KH, Vuolteenaho O, et al. Hypoxia stimulates release of ANP and BNP from perfused rat ventricular myocardium. *Am J Physiol* 1994;266(4 Pt 2):H1572-H1580.
47. Riddervold F, Smiseth OA, Hall C, Groves G, Risoe C. Rate-induced increase in plasma atrial natriuretic factor can occur independently of changes in atrial wall stretch. *Am J Physiol* 1991;260(6 Pt 2): H1953-H1958.
48. Ogawa Y, Itoh H, Nakagawa O, et al. Characterization of the 5'-flanking region and chromosomal assignment of the human brain natriuretic peptide gene. *J Mol Med* 1995;73(9):457-463.
49. Tamura N, Ogawa Y, Yasoda A, Itoh H, Saito Y, Nakao K. Two cardiac natriuretic peptide genes (atrial natriuretic peptide and brain natriuretic peptide) are organized in tandem in the mouse and human genomes. *J Mol Cell Cardiol* 1996;28(8):1811-1815.
50. Sawada Y, Suda M, Yokoyama H, et al. Stretch-induced hypertrophic growth of cardiocytes and processing of brain-type natriuretic peptide are controlled by proprotein-processing endoprotease furin. *J Biol Chem* 1997;272(33):20,545-20,554.
51. Tateyama H, Hino J, Minamino N, et al. Concentrations and molecular forms of human brain natriuretic peptide in plasma. *Biochem Biophys Res Commun* 1992;185(2):760-767.



52. Yandle TG, Richards AM, Gilbert A, Fisher S, Holmes S, Espiner EA. Assay of brain natriuretic peptide (BNP) in human plasma: evidence for high molecular weight BNP as a major plasma component in heart failure. *J Clin Endocrinol Metab* 1993;76(4):832–838.
53. Hunt PJ, Yandle TG, Nicholls MG, Richards AM, Espiner EA. The amino-terminal portion of pro-brain natriuretic peptide (Pro-BNP) circulates in human plasma. *Biochem Biophys Res Commun* 1995; 214(3):1175–1183.
54. Hunt PJ, Espiner EA, Nicholls MG, Richards AM, Yandle TG. The role of the circulation in processing pro-brain natriuretic peptide (proBNP) to amino-terminal BNP and BNP-32. *Peptides* 1997;18(10): 1475–1481.
55. Hunt PJ, Richards AM, Nicholls MG, Yandle TG, Doughty RN, Espiner EA. Immunoreactive amino-terminal pro-brain natriuretic peptide (NT-PROBNP): a new marker of cardiac impairment. *Clin Endocrinol (Oxf)* 1997;47(3):287–296.
56. Yasue H, Yoshimura M, Sumida H, et al. Localization and mechanism of secretion of B-type natriuretic peptide in comparison with those of A-type natriuretic peptide in normal subjects and patients with heart failure. *Circulation* 1994;90(1):195–203.
57. Lang CC, Choy AM, Struthers AD. Atrial and brain natriuretic peptides: a dual natriuretic peptide system potentially involved in circulatory homeostasis. *Clin Sci (Lond)* 1992;83(5):519–527.
58. Tsuruda T, Boerrigter G, Huntley BK, et al. Brain natriuretic peptide is produced in cardiac fibroblasts and induces matrix metalloproteinases. *Circ Res* 2002;91(12):1127–1134.
59. Ogawa Y, Nakao K, Mukoyama M, et al. Natriuretic peptides as cardiac hormones in normotensive and spontaneously hypertensive rats: the ventricle is a major site of synthesis and secretion of brain natriuretic peptide. *Circ Res* 1991;69(2):491–500.
60. Kinnunen P, Vuolteenaho O, Ruskoaho H. Mechanisms of atrial and brain natriuretic peptide release from rat ventricular myocardium: effect of stretching. *Endocrinology* 1993;132(5):1961–1970.
61. Hama N, Itoh H, Shirakami G, et al. Rapid ventricular induction of brain natriuretic peptide gene expression in experimental acute myocardial infarction. *Circulation* 1995;92(6):1558–1564.
62. Takahashi T, Allen PD, Izumo S. Expression of A-, B-, and C-type natriuretic peptide genes in failing and developing human ventricles: correlation with expression of the Ca(2+)-ATPase gene. *Circ Res* 1992;71(1):9–17.
63. Luchner A, Stevens TL, Borgeson DD, et al. Differential atrial and ventricular expression of myocardial BNP during evolution of heart failure. *Am J Physiol* 1998;274(5 Pt 2):H1684–H1689.
64. Murakami Y, Shimada T, Inoue S, et al. New insights into the mechanism of the elevation of plasma brain natriuretic polypeptide levels in patients with left ventricular hypertrophy. *Can J Cardiol* 2002; 18(12):1294–1300.
65. Mantymaa P, Vuolteenaho O, Marttila M, Ruskoaho H. Atrial stretch induces rapid increase in brain natriuretic peptide but not in atrial natriuretic peptide gene expression in vitro. *Endocrinology* 1993;133 (3):1470–1473.
66. Magga J, Marttila M, Mantymaa P, Vuolteenaho O, Ruskoaho H. Brain natriuretic peptide in plasma, atria, and ventricles of vasopressin- and phenylephrine-infused conscious rats. *Endocrinology* 1994; 134(6):2505–2515.
67. Bruneau BG, Piazza LA, De Bold AJ. Alpha 1-adrenergic stimulation of isolated rat atria results in discoordinate increases in natriuretic peptide secretion and gene expression and enhances Egr-1 and c-Myc expression. *Endocrinology* 1996;137(1):137–143.
68. Leskinen H, Vuolteenaho O, Ruskoaho H. Combined inhibition of endothelin and angiotensin II receptors blocks volume load-induced cardiac hormone release. *Circ Res* 1997;80(1):114–123.
69. Bianciotti LG, De Bold AJ. Modulation of cardiac natriuretic peptide gene expression following endothelin type A receptor blockade in renovascular hypertension. *Cardiovasc Res* 2001;49(4):808–816.
70. Liang F, Gardner DG. Autocrine/paracrine determinants of strain-activated brain natriuretic peptide gene expression in cultured cardiac myocytes. *J Biol Chem* 1998;273(23):14,612–14,619.
71. Magga J, Vuolteenaho O, Marttila M, Ruskoaho H. Endothelin-1 is involved in stretch-induced early activation of B-type natriuretic peptide gene expression in atrial but not in ventricular myocytes: acute effects of mixed ET(A)/ET(B) and AT1 receptor antagonists in vivo and in vitro. *Circulation* 1997;96 (9):3053–3062.
72. Lang CC, Choy AM, Turner K, Tobin R, Coutie W, Struthers AD. The effect of intravenous saline loading on plasma levels of brain natriuretic peptide in man. *J Hypertens* 1993;11(7):737–741.
73. Richards AM, Crozier IG, Holmes SJ, Espiner EA, Yandle TG, Frampton C. Brain natriuretic peptide: natriuretic and endocrine effects in essential hypertension. *J Hypertens* 1993;11(2):163–170.

74. Lang CC, Coutie WJ, Khong TK, Choy AM, Struthers AD. Dietary sodium loading increases plasma brain natriuretic peptide levels in man. *J Hypertens* 1991;9(9):779–782.
75. Ogawa Y, Nakao K, Nakagawa O, et al. Human C-type natriuretic peptide: characterization of the gene and peptide. *Hypertension* 1992;19(6 Pt 2):809–813.
76. Minamino N, Aburaya M, Kojima M, Miyamoto K, Kangawa K, Matsuo H. Distribution of C-type natriuretic peptide and its messenger RNA in rat central nervous system and peripheral tissue. *Biochem Biophys Res Commun* 1993;197(1):326–335.
77. Suga S, Nakao K, Itoh H, et al. Endothelial production of C-type natriuretic peptide and its marked augmentation by transforming growth factor-beta: possible existence of “vascular natriuretic peptide system.” *J Clin Invest* 1992;90(3):1145–1149.
78. Horio T, Tokudome T, Maki T, et al. Gene expression, secretion, and autocrine action of C-type natriuretic peptide in cultured adult rat cardiac fibroblasts. *Endocrinology* 2003;144(6):2279–2284.
79. Yamamoto K, Ikeda U, Shimada K. Natriuretic peptides modulate nitric oxide synthesis in cytokine-stimulated cardiac myocytes. *J Mol Cell Cardiol* 1997;29(9):2375–2382.
80. Kalra PR, Clague JR, Bolger AP, et al. Myocardial production of C-type natriuretic peptide in chronic heart failure. *Circulation* 2003;107(4):571–573.
81. Wright SP, Prickett TC, Doughty RN, et al. Amino-terminal pro-C-type natriuretic peptide in heart failure. *Hypertension* 2004;43(1):94–100.
82. Porter JG, Arfsten A, Fuller F, Miller JA, Gregory LC, Lewicki JA. Isolation and functional expression of the human atrial natriuretic peptide clearance receptor cDNA. *Biochem Biophys Res Commun* 1990;171(2):796–803.
83. Maack T. Receptors of atrial natriuretic factor. *Annu Rev Physiol* 1992;54:11–27.
84. Misono KS. Natriuretic peptide receptor: structure and signaling. *Mol Cell Biochem* 2002;230(1–2):49–60.
85. Tremblay J, Desjardins R, Hum D, Gutkowska J, Hamet P. Biochemistry and physiology of the natriuretic peptide receptor guanylyl cyclases. *Mol Cell Biochem* 2002;230(1–2):31–47.
86. Matsukawa N, Grzesik WJ, Takahashi N, et al. The natriuretic peptide clearance receptor locally modulates the physiological effects of the natriuretic peptide system. *Proc Natl Acad Sci USA* 1999;96(13):7403–7408.
87. Chinkers M, Garbers DL, Chang MS, et al. A membrane form of guanylate cyclase is an atrial natriuretic peptide receptor. *Nature* 1989;338(6210):78–83.
88. Koller KJ, Goeddel DV. Molecular biology of the natriuretic peptides and their receptors. *Circulation* 1992;86(4):1081–1088.
89. Gutkowska J, Nemer M. Structure, expression, and function of atrial natriuretic factor in extraatrial tissues. *Endocr Rev* 1989;10(4):519–536.
90. Nakao K, Itoh H, Kambayashi Y, et al. Rat brain natriuretic peptide: isolation from rat heart and tissue distribution. *Hypertension* 1990;15(6 Pt 2):774–778.
91. Garbers DL, Lowe DG. Guanylyl cyclase receptors. *J Biol Chem* 1994;269(49):30,741–30,744.
92. Potter LR, Hunter T. Guanylyl cyclase-linked natriuretic peptide receptors: structure and regulation. *J Biol Chem* 2001;276(9):6057–6060.
93. Maack T, Suzuki M, Almeida FA, et al. Physiological role of silent receptors of atrial natriuretic factor. *Science* 1987;238(4827):675–678.
94. Murthy KS, Teng BQ, Zhou H, Jin JG, Grider JR, Makhlof GM. G(i-1)/G(i-2)-dependent signaling by single-transmembrane natriuretic peptide clearance receptor. *Am J Physiol Gastrointest Liver Physiol* 2000;278(6):G974–G980.
95. Kone BC. Molecular biology of natriuretic peptides and nitric oxide synthases. *Cardiovasc Res* 2001;51(3):429–441.
96. Maack T, Okolicany J, Koh GY, Price DA. Functional properties of atrial natriuretic factor receptors. *Semin Nephrol* 1993;13(1):50–60.
97. Suga S, Nakao K, Hosoda K, et al. Receptor selectivity of natriuretic peptide family, atrial natriuretic peptide, brain natriuretic peptide, and C-type natriuretic peptide. *Endocrinology* 1992;130(1):229–239.
98. Feil R, Lohmann SM, de JH, Walter U, Hofmann F. Cyclic GMP-dependent protein kinases and the cardiovascular system: insights from genetically modified mice. *Circ Res* 2003;93(10):907–916.
99. Kenny AJ, Bourne A, Ingram J. Hydrolysis of human and pig brain natriuretic peptides, urodilatin, C-type natriuretic peptide and some C-receptor ligands by endopeptidase-24.11. *Biochem J* 1993;291(Pt 1):83–88.
100. Nakao K, Ogawa Y, Suga S, Imura H. Molecular biology and biochemistry of the natriuretic peptide system. II: Natriuretic peptide receptors. *J Hypertens* 1992;10(10):1111–1114.

101. Sonnenberg JL, Sakane Y, Jeng AY, et al. Identification of protease 3.4.24.11 as the major atrial natriuretic factor degrading enzyme in the rat kidney. *Peptides* 1988;9(1):173–180.
102. Charles CJ, Espiner EA, Nicholls MG, et al. Clearance receptors and endopeptidase 24.11: equal role in natriuretic peptide metabolism in conscious sheep. *Am J Physiol* 1996;271(2 Pt 2):R373–R380.
103. Rademaker MT, Charles CJ, Kosoglou T, et al. Clearance receptors and endopeptidase: equal role in natriuretic peptide metabolism in heart failure. *Am J Physiol* 1997;273(5 Pt 2):H2372–H2379.
104. Smith MW, Espiner EA, Yandle TG, Charles CJ, Richards AM. Delayed metabolism of human brain natriuretic peptide reflects resistance to neutral endopeptidase. *J Endocrinol* 2000;167(2):239–246.
105. McCullough PA, Sandberg KR. B-type natriuretic peptide and renal disease. *Heart Fail Rev* 2003;8(4):355–358.
106. Ng LL, Geeranavar S, Jennings SC, Loke I, O'Brien RJ. Diagnosis of heart failure using urinary natriuretic peptides. *Clin Sci (Lond)* 2004;106(2):129–133.
107. Mehra MR, Uber PA, Park MH, et al. Obesity and suppressed B-type natriuretic peptide levels in heart failure. *J Am Coll Cardiol* 2004;43(9):1590–1595.
108. Wang TJ, Larson MG, Levy D, et al. Impact of obesity on plasma natriuretic peptide levels. *Circulation* 2004;109(5):594–600.
109. Sarzani R, ssi-Fulgheri P, Paci VM, Espinosa E, Rappelli A. Expression of natriuretic peptide receptors in human adipose and other tissues. *J Endocrinol Invest* 1996;19(9):581–585.
110. Sarzani R, Paci VM, Zingaretti CM, et al. Fasting inhibits natriuretic peptides clearance receptor expression in rat adipose tissue. *J Hypertens* 1995;13(11):1241–1246.
111. Crandall DL, Ferraro GD, Cervoni P. Effect of experimental obesity and subsequent weight reduction upon circulating atrial natriuretic peptide. *Proc Soc Exp Biol Med* 1989;191(4):352–356.
112. Thibault G, Murthy KK, Gutkowska J, et al. NH<sub>2</sub>-terminal fragment of rat pro-atrial natriuretic factor in the circulation: identification, radioimmunoassay and half-life. *Peptides* 1988;9(1):47–53.
113. Sundsfjord JA, Thibault G, Larochelle P, Cantin M. Identification and plasma concentrations of the N-terminal fragment of proatrial natriuretic factor in man. *J Clin Endocrinol Metab* 1988;66(3):605–610.
114. Espiner EA, Richards AM, Yandle TG, Nicholls MG. Natriuretic hormones. *Endocrinol Metab Clin North Am* 1995;24(3):481–509.
115. Pemberton CJ, Johnson ML, Yandle TG, Espiner EA. Deconvolution analysis of cardiac natriuretic peptides during acute volume overload. *Hypertension* 2000;36(3):355–359.
116. Charles CJ, Espiner EA, Richards AM, Nicholls MG, Yandle TG. Biological actions and pharmacokinetics of C-type natriuretic peptide in conscious sheep. *Am J Physiol* 1995;268(1 Pt 2):R201–R207.
117. Charles CJ, Espiner EA, Richards AM. Cardiovascular actions of ANF: contributions of renal, neuro-humoral, and hemodynamic factors in sheep. *Am J Physiol* 1993;264(3 Pt 2):R533–R538.
118. Richards AM, Tonolo G, Montorsi P, et al. Low dose infusions of 26- and 28-amino acid human atrial natriuretic peptides in normal man. *J Clin Endocrinol Metab* 1988;66(3):465–472.
119. Tonolo G, Richards AM, Manunta P, et al. Low-dose infusion of atrial natriuretic factor in mild essential hypertension. *Circulation* 1989;80(4):893–902.
120. Wei CM, Aarhus LL, Miller VM, Burnett JC Jr. Action of C-type natriuretic peptide in isolated canine arteries and veins. *Am J Physiol* 1993;264(1 Pt 2):H71–H73.
121. Cody RJ, Covit AB, Schaer GL, Laragh JH, Sealey JE, Feldschuh J. Sodium and water balance in chronic congestive heart failure. *J Clin Invest* 1986;77(5):1441–1452.
122. Wijeyaratne CN, Moulton PJ. The effect of alpha human atrial natriuretic peptide on plasma volume and vascular permeability in normotensive subjects. *J Clin Endocrinol Metab* 1993;76(2):343–346.
123. Burnett JC Jr, Granger JP, Ogenorth TJ. Effects of synthetic atrial natriuretic factor on renal function and renin release. *Am J Physiol* 1984;247(5 Pt 2):F863–F866.
124. Atarashi K, Mulrow PJ, Franco-Saenz R. Effect of atrial peptides on aldosterone production. *J Clin Invest* 1985;76(5):1807–1811.
125. Uemasu J, Matsumoto H, Kitano M, Kawasaki H. Suppression of plasma endothelin-1 level by alpha-human atrial natriuretic peptide and angiotensin converting enzyme inhibition in normal men. *Life Sci* 1993;53(11):969–974.
126. Floras JS. Sympathoinhibitory effects of atrial natriuretic factor in normal humans. *Circulation* 1990;81(6):1860–1873.
127. Yang RH, Jin HK, Wyss JM, Chen YF, Oparil S. Pressor effect of blocking atrial natriuretic peptide in nucleus tractus solitarius. *Hypertension* 1992;19(2):198–205.
128. Burnett JC Jr, Rubanyi GM, Edwards BS, Schwab TR, Zimmerman RS, Vanhoutte PM. Atrial natriuretic peptide decreases cardiac output independent of coronary vasoconstriction. *Proc Soc Exp Biol Med* 1987;186(3):313–318.

129. Clarkson PB, Wheeldon NM, Macleod C, Coutie W, MacDonald TM. Brain natriuretic peptide: effect on left ventricular filling patterns in healthy subjects. *Clin Sci (Lond)* 1995;88(2):159–164.
130. Kishimoto I, Rossi K, Garbers DL. A genetic model provides evidence that the receptor for atrial natriuretic peptide (guanylyl cyclase-A) inhibits cardiac ventricular myocyte hypertrophy. *Proc Natl Acad Sci USA* 2001;98(5):2703–2706.
131. Holtwick R, van EM, Skryabin BV, et al. Pressure-independent cardiac hypertrophy in mice with cardiomyocyte-restricted inactivation of the atrial natriuretic peptide receptor guanylyl cyclase-A. *J Clin Invest* 2003;111(9):1399–1407.
132. Knowles JW, Esposito G, Mao L, et al. Pressure-independent enhancement of cardiac hypertrophy in natriuretic peptide receptor A-deficient mice. *J Clin Invest* 2001;107(8):975–984.
133. John SW, Krege JH, Oliver PM, et al. Genetic decreases in atrial natriuretic peptide and salt-sensitive hypertension. *Science* 1995;267(5198):679–681.
134. Tamura N, Ogawa Y, Chusho H, et al. Cardiac fibrosis in mice lacking brain natriuretic peptide. *Proc Natl Acad Sci USA* 2000;97(8):4239–4244.
135. Oliver PM, Fox JE, Kim R, et al. Hypertension, cardiac hypertrophy, and sudden death in mice lacking natriuretic peptide receptor A. *Proc Natl Acad Sci USA* 1997;94(26):14,730–14,735.
136. Brown J, Chen Q, Hong G. An autocrine system for C-type natriuretic peptide within rat carotid neointima during arterial repair. *Am J Physiol* 1997;272(6 Pt 2):H2919–H2931.
137. Wennberg PW, Miller VM, Rabelink T, Burnett JC Jr. Further attenuation of endothelium-dependent relaxation imparted by natriuretic peptide receptor antagonism. *Am J Physiol* 1999;277(4 Pt 2):H1618–H1621.
138. Komatsu Y, Itoh H, Suga S, et al. Regulation of endothelial production of C-type natriuretic peptide in coculture with vascular smooth muscle cells: role of the vascular natriuretic peptide system in vascular growth inhibition. *Circ Res* 1996;78(4):606–614.
139. Furuya M, Aisaka K, Miyazaki T, et al. C-type natriuretic peptide inhibits intimal thickening after vascular injury. *Biochem Biophys Res Commun* 1993;193(1):248–253.
140. Naruko T, Ueda M, van der Wal AC, et al. C-type natriuretic peptide in human coronary atherosclerotic lesions. *Circulation* 1996;94(12):3103–3108.
141. Tokudome T, Horio T, Soeki T, et al. Inhibitory effect of C-type natriuretic peptide (CNP) on cultured cardiac myocyte hypertrophy: interference between CNP and endothelin-1 signaling pathways. *Endocrinology* 2004;145(5):2131–2140.
142. Marin-Grez M, Fleming JT, Steinhausen M. Atrial natriuretic peptide causes pre-glomerular vasodilatation and post-glomerular vasoconstriction in rat kidney. *Nature* 1986;324(6096):473–476.
143. Grantham JA, Borgeson DD, Burnett JC Jr. BNP: pathophysiological and potential therapeutic roles in acute congestive heart failure. *Am J Physiol* 1997;272(4 Pt 2):R1077–R1083.
144. Fried TA, McCoy RN, Osgood RW, Stein JH. Effect of atriopeptin II on determinants of glomerular filtration rate in the in vitro perfused dog glomerulus. *Am J Physiol* 1986;250(6 Pt 2):F1119–F1122.
145. Harris PJ, Thomas D, Morgan TO. Atrial natriuretic peptide inhibits angiotensin-stimulated proximal tubular sodium and water reabsorption. *Nature* 1987;326(6114):697–698.
146. Dillingham MA, Anderson RJ. Inhibition of vasopressin action by atrial natriuretic factor. *Science* 1986;231(4745):1572, 1573.
147. Zeidel ML, Kikeri D, Silva P, Burrowes M, Brenner BM. Atrial natriuretic peptides inhibit conductive sodium uptake by rabbit inner medullary collecting duct cells. *J Clin Invest* 1988;82(3):1067–1074.
148. Wada A, Tsutamoto T, Matsuda Y, Kinoshita M. Cardiorenal and neurohumoral effects of endogenous atrial natriuretic peptide in dogs with severe congestive heart failure using a specific antagonist for guanylate cyclase-coupled receptors. *Circulation* 1994;89(5):2232–2240.
149. Hunt PJ, Richards AM, Espiner EA, Nicholls MG, Yandle TG. Bioactivity and metabolism of C-type natriuretic peptide in normal man. *J Clin Endocrinol Metab* 1994;78(6):1428–1435.
150. Hunt PJ, Espiner EA, Nicholls MG, Richards AM, Yandle TG. Differing biological effects of equimolar atrial and brain natriuretic peptide infusions in normal man. *J Clin Endocrinol Metab* 1996;81(11):3871–3876.
151. Packer M. The neurohormonal hypothesis: a theory to explain the mechanism of disease progression in heart failure. *J Am Coll Cardiol* 1992;20(1):248–254.
152. Richards AM, Cleland JG, Tonolo G, et al. Plasma alpha natriuretic peptide in cardiac impairment. *Br Med J (Clin Res Ed)* 1986;293(6544):409–412.
153. Richards AM, Crozier IG, Yandle TG, Espiner EA, Ikram H, Nicholls MG. Brain natriuretic factor: regional plasma concentrations and correlations with haemodynamic state in cardiac disease. *Br Heart J* 1993;69(5):414–417.

154. Wei CM, Heublein DM, Perrella MA, et al. Natriuretic peptide system in human heart failure. *Circulation* 1993;88(3):1004–1009.
155. Omland T, Aakvaag A, Vik-Mo H. Plasma cardiac natriuretic peptide determination as a screening test for the detection of patients with mild left ventricular impairment. *Heart* 1996;76(3):232–237.
156. Remes J, Tikkanen I, Fyhrquist F, Pyorala K. Neuroendocrine activity in untreated heart failure. *Br Heart J* 1991;65(5):249–255.
157. Cheng V, Kazanagra R, Garcia A, et al. A rapid bedside test for B-type peptide predicts treatment outcomes in patients admitted for decompensated heart failure: a pilot study. *J Am Coll Cardiol* 2001;37(2):386–391.
158. Krishnaswamy P, Lubien E, Clopton P, et al. Utility of B-natriuretic peptide levels in identifying patients with left ventricular systolic or diastolic dysfunction. *Am J Med* 2001;111(4):274–279.
159. Maisel AS, McCord J, Nowak RM, et al. Bedside B-Type natriuretic peptide in the emergency diagnosis of heart failure with reduced or preserved ejection fraction: results from the Breathing Not Properly Multinational Study. *J Am Coll Cardiol* 2003;41(11):2010–2017.
160. Lerman A, Gibbons RJ, Rodeheffer RJ, et al. Circulating N-terminal atrial natriuretic peptide as a marker for symptomless left-ventricular dysfunction. *Lancet* 1993;341(8853):1105–1109.
161. Yamamoto K, Burnett JC Jr, Jougasaki M, et al. Superiority of brain natriuretic peptide as a hormonal marker of ventricular systolic and diastolic dysfunction and ventricular hypertrophy. *Hypertension* 1996;28(6):988–994.
162. Sumida H, Yasue H, Yoshimura M, et al. Comparison of secretion pattern between A-type and B-type natriuretic peptides in patients with old myocardial infarction. *J Am Coll Cardiol* 1995;25(5):1105–1110.
163. McCullough PA, Duc P, Omland T, et al. B-type natriuretic peptide and renal function in the diagnosis of heart failure: an analysis from the Breathing Not Properly Multinational Study. *Am J Kidney Dis* 2003;41(3):571–579.
164. Stevens TL, Burnett JC Jr, Kinoshita M, Matsuda Y, Redfield MM. A functional role for endogenous atrial natriuretic peptide in a canine model of early left ventricular dysfunction. *J Clin Invest* 1995;95(3):1101–1108.
165. Cataliotti A, Boerrigter G, Costello-Boerrigter LC, et al. Brain natriuretic peptide enhances renal actions of furosemide and suppresses furosemide-induced aldosterone activation in experimental heart failure. *Circulation* 2004;109(13):1680–1685.
166. de Lemos JA, McGuire DK, Drazner MH. B-type natriuretic peptide in cardiovascular disease. *Lancet* 2003;362(9380):316–322.
167. Marcus LS, Hart D, Packer M, et al. Hemodynamic and renal excretory effects of human brain natriuretic peptide infusion in patients with congestive heart failure: a double-blind, placebo-controlled, randomized crossover trial. *Circulation* 1996;94(12):3184–3189.
168. Colucci WS, Elkayam U, Horton DP, et al. Intravenous nesiritide, a natriuretic peptide, in the treatment of decompensated congestive heart failure. Nesiritide Study Group. *N Engl J Med* 2000;343(4):246–253.
169. VMAC investigators. Intravenous nesiritide vs nitroglycerin for treatment of decompensated congestive heart failure: a randomized controlled trial. *JAMA* 2002;287(12):1531–1540.
170. Chen HH, Redfield MM, Nordstrom LJ, Horton DP, Burnett JC Jr. Subcutaneous administration of the cardiac hormone BNP in symptomatic human heart failure. *J Card Fail* 2004;10(2):115–119.
171. McClean DR, Ikram H, Garlick AH, Richards AM, Nicholls MG, Crozier IG. The clinical, cardiac, renal, arterial and neurohormonal effects of omapatrilat, a vasopeptidase inhibitor, in patients with chronic heart failure. *J Am Coll Cardiol* 2000;36(2):479–486.
172. Packer M, Califf RM, Konstam MA, et al. Comparison of omapatrilat and enalapril in patients with chronic heart failure: the Omapatrilat Versus Enalapril Randomized Trial of Utility in Reducing Events (OVERTURE). *Circulation* 2002;106(8):920–926.
173. Steinhilber ME, Cochrane KL, Field LJ. Hypotension in transgenic mice expressing atrial natriuretic factor fusion genes. *Hypertension* 1990;16(3):301–307.
174. Ogawa Y, Itoh H, Tamura N, et al. Molecular cloning of the complementary DNA and gene that encode mouse brain natriuretic peptide and generation of transgenic mice that overexpress the brain natriuretic peptide gene. *J Clin Invest* 1994;93(5):1911–1921.
175. John SW, Veress AT, Honrath U, et al. Blood pressure and fluid-electrolyte balance in mice with reduced or absent ANP. *Am J Physiol* 1996;271(1 Pt 2):R109–R114.
176. Lopez MJ, Wong SK, Kishimoto I, et al. Salt-resistant hypertension in mice lacking the guanylyl cyclase-A receptor for atrial natriuretic peptide. *Nature* 1995;378(6552):65–68.
177. Kuhn M, Holtwick R, Baba HA, Perriard JC, Schmitz W, Ehler E. Progressive cardiac hypertrophy and dysfunction in atrial natriuretic peptide receptor (GC-A) deficient mice. *Heart* 2002;87(4):368–374.

178. Wang TJ, Larson MG, Levy D, et al. Heritability and genetic linkage of plasma natriuretic peptide levels. *Circulation* 2003;108(1):13–16.
179. Nannipieri M, Manganiello M, Pezzatini A, De BA, Seghieri G, Ferrannini E. Polymorphisms in the hANP (human atrial natriuretic peptide) gene, albuminuria, and hypertension. *Hypertension* 2001;37(6):1416–1422.
180. Nannipieri M, Posadas R, Williams K, et al. Association between polymorphisms of the atrial natriuretic peptide gene and proteinuria: a population-based study. *Diabetologia* 2003;46(3):429–432.
181. Ono K, Mannami T, Baba S, Tomoike H, Suga S, Iwai N. A single-nucleotide polymorphism in C-type natriuretic peptide gene may be associated with hypertension. *Hypertens Res* 2002;25(5):727–730.
182. Talwar S, Downie PF, Squire IB, Davies JE, Barnett DB, Ng LL. Plasma N-terminal pro BNP and cardiostrophin-1 are elevated in aortic stenosis. *Eur J Heart Fail* 2001;3(1):15–19.
183. Qi W, Mathisen P, Kjekshus J, et al. Natriuretic peptides in patients with aortic stenosis. *Am Heart J* 2001;142(4):725–732.
184. Gerber IL, Stewart RA, Legget ME, et al. Increased plasma natriuretic peptide levels reflect symptom onset in aortic stenosis. *Circulation* 2003;107(14):1884–1890.
185. Sutton TM, Stewart RA, Gerber IL, et al. Plasma natriuretic peptide levels increase with symptoms and severity of mitral regurgitation. *J Am Coll Cardiol* 2003;41(12):2280–2287.
186. Jougasaki M, Yasue H, Mukoyama M, Nakao K, Takahashi K. Appearance of atrial natriuretic peptide in the ventricles in patients with myocardial infarction. *Am Heart J* 1990;119(1):92–96.
187. Morita E, Yasue H, Yoshimura M, et al. Increased plasma levels of brain natriuretic peptide in patients with acute myocardial infarction. *Circulation* 1993;88(1):82–91.
188. Omland T, Aakvaag A, Bonarjee VV, et al. Plasma brain natriuretic peptide as an indicator of left ventricular systolic function and long-term survival after acute myocardial infarction: comparison with plasma atrial natriuretic peptide and N-terminal proatrial natriuretic peptide. *Circulation* 1996;93(11):1963–1969.
189. Richards AM, Nicholls MG, Yandle TG, et al. Plasma N-terminal pro-brain natriuretic peptide and adrenomedullin: new neurohormonal predictors of left ventricular function and prognosis after myocardial infarction. *Circulation* 1998;97(19):1921–1929.
190. Omland T, Persson A, Ng L, et al. N-terminal pro-B-type natriuretic peptide and long-term mortality in acute coronary syndromes. *Circulation* 2002;106(23):2913–2918.
191. de Lemos JA, Morrow DA, Bentley JH, et al. The prognostic value of B-type natriuretic peptide in patients with acute coronary syndromes. *N Engl J Med* 2001;345(14):1014–1021.
192. Richards AM, Nicholls MG, Espiner EA, et al. B-type natriuretic peptides and ejection fraction for prognosis after myocardial infarction. *Circulation* 2003;107(22):2786–2792.
193. James SK, Lindahl B, Siegbahn A, et al. N-terminal pro-brain natriuretic peptide and other risk markers for the separate prediction of mortality and subsequent myocardial infarction in patients with unstable coronary artery disease: a Global Utilization of Strategies To Open occluded arteries (GUSTO)-IV sub-study. *Circulation* 2003;108(3):275–281.
194. Kikuta K, Yasue H, Yoshimura M, et al. Increased plasma levels of B-type natriuretic peptide in patients with unstable angina. *Am Heart J* 1996;132(1 Pt 1):101–107.
195. Talwar S, Squire IB, Downie PF, Davies JE, Ng LL. Plasma N terminal pro-brain natriuretic peptide and cardiostrophin 1 are raised in unstable angina. *Heart* 2000;84(4):421–424.
196. Kyriakides ZS, Markianos M, Michalis L, Antoniadis A, Nikolaou NI, Kremastinos DT. Brain natriuretic peptide increases acutely and much more prominently than atrial natriuretic peptide during coronary angioplasty. *Clin Cardiol* 2000;23(4):285–288.
197. Tateishi J, Masutani M, Ohyanagi M, Iwasaki T. Transient increase in plasma brain (B-type) natriuretic peptide after percutaneous transluminal coronary angioplasty. *Clin Cardiol* 2000;23(10):776–780.
198. Marumoto K, Hamada M, Hiwada K. Increased secretion of atrial and brain natriuretic peptides during acute myocardial ischaemia induced by dynamic exercise in patients with angina pectoris. *Clin Sci (Lond)* 1995;88(5):551–556.
199. Goetze JP, Christoffersen C, Perko M, et al. Increased cardiac BNP expression associated with myocardial ischemia. *FASEB J* 2003;17(9):1105–1107.
200. Bibbins-Domingo K, Ansari M, Schiller NB, Massie B, Whooley MA. B-type natriuretic peptide and ischemia in patients with stable coronary disease: data from the Heart and Soul study. *Circulation* 2003;108(24):2987–2992.
201. D'Souza SP, Yellon DM, Martin C, et al. B-type natriuretic peptide limits infarct size in rat isolated hearts via KATP channel opening. *Am J Physiol Heart Circ Physiol* 2003;284(5):H1592–H1600.

202. D'Souza SP, Baxter GF. B Type natriuretic peptide: a good omen in myocardial ischaemia? *Heart* 2003;89(7):707–709.
203. Steiner G. Diabetes and atherosclerosis: an overview. *Diabetes* 1981;30(Suppl 2):1–7.
204. Kannel WB, McGee DL. Diabetes and cardiovascular disease: the Framingham Study. *JAMA* 1979;241(19):2035–2038.
205. Butler R, MacDonald TM, Struthers AD, Morris AD. The clinical implications of diabetic heart disease. *Eur Heart J* 1998;19(11):1617–1627.
206. Grossman E, Shemesh J, Shamiss A, Thaler M, Carroll J, Rosenthal T. Left ventricular mass in diabetes-hypertension. *Arch Intern Med* 1992;152(5):1001–1004.
207. Siebenhofer A, Ng LL, Plank J, Berghold A, Hodl R, Pieber TR. Plasma N-terminal pro-brain natriuretic peptide in Type 1 diabetic patients with and without diabetic nephropathy. *Diabet Med* 2003;20(7):535–539.
208. Yano Y, Katsuki A, Gabazza EC, et al. Plasma brain natriuretic peptide levels in normotensive non-insulin-dependent diabetic patients with microalbuminuria. *J Clin Endocrinol Metab* 1999;84(7):2353–2356.
209. Asakawa H, Fukui T, Tokunaga K, Kawakami F. Plasma brain natriuretic peptide levels in normotensive Type 2 diabetic patients without cardiac disease and macroalbuminuria. *J Diabetes Complications* 2002;16(3):209–213.
210. Magnusson M, Melander O, Israelsson B, Grubb A, Groop L, Jovinge S. Elevated plasma levels of Nt-proBNP in patients with type 2 diabetes without overt cardiovascular disease. *Diabetes Care* 2004;27(8):1929–1935.
211. Christoffersen C, Goetze JP, Bartels ED, et al. Chamber-dependent expression of brain natriuretic peptide and its mRNA in normal and diabetic pig heart. *Hypertension* 2002;40(1):54–60.
212. Rosenkranz AC, Hood SG, Woods RL, Dusting GJ, Ritchie RH. B-type natriuretic peptide prevents acute hypertrophic responses in the diabetic rat heart: importance of cyclic GMP. *Diabetes* 2003;52(9):2389–2395.
213. McKenna K, Smith D, Tormey W, Thompson CJ. Acute hyperglycaemia causes elevation in plasma atrial natriuretic peptide concentrations in Type 1 diabetes mellitus. *Diabet Med* 2000;17(7):512–517.
214. Epshteyn V, Morrison K, Krishnaswamy P, et al. Utility of B-type natriuretic peptide (BNP) as a screen for left ventricular dysfunction in patients with diabetes. *Diabetes Care* 2003;26(7):2081–2087.
215. Struthers AD, Morris AD. Screening for and treating left-ventricular abnormalities in diabetes mellitus: a new way of reducing cardiac deaths. *Lancet* 2002;359(9315):1430–1432.
216. Wang TJ, Larson MG, Levy D, et al. Impact of age and sex on plasma natriuretic peptide levels in healthy adults. *Am J Cardiol* 2002;90(3):254–258.
217. Redfield MM, Rodeheffer RJ, Jacobsen SJ, Mahoney DW, Bailey KR, Burnett JC Jr. Plasma brain natriuretic peptide concentration: impact of age and gender. *J Am Coll Cardiol* 2002;40(5):976–982.
218. Raymond I, Groenning BA, Hildebrandt PR, et al. The influence of age, sex and other variables on the plasma level of N-terminal pro brain natriuretic peptide in a large sample of the general population. *Heart* 2003;89(7):745–751.
219. Chusho H, Tamura N, Ogawa Y, et al. Dwarfism and early death in mice lacking C-type natriuretic peptide. *Proc Natl Acad Sci USA* 2001;98(7):4016–4021.
220. Suda M, Ogawa Y, Tanaka K, et al. Skeletal overgrowth in transgenic mice that overexpress brain natriuretic peptide. *Proc Natl Acad Sci USA* 1998;95(5):2337–2342.
221. Oliver PM, John SW, Purdy KE, et al. Natriuretic peptide receptor 1 expression influences blood pressures of mice in a dose-dependent manner. *Proc Natl Acad Sci USA* 1998;95(5):2547–2551.

# 22

---

## Analytic Issues for Clinical Use of B-Type Natriuretic Peptide and N-Terminal Pro B-Type Natriuretic Peptide

---

*Johannes Mair, MD*

### CONTENTS

INTRODUCTION

METHODS OF DETERMINATION:

IMMUNOMETRIC (“SANDWICH”) ASSAYS

BLOOD-SAMPLING CONDITIONS AND SAMPLE STABILITY

REFERENCE RANGES AND BIOLOGICAL VARIATION

FALSE RESULTS

CONCLUSION

REFERENCES

---

### SUMMARY

B-type natriuretic peptide (BNP) and the N-terminal fragment of its prohormone (NT-proBNP) have emerged as the preferred candidates for diagnosis of heart failure, as well as other clinical applications. Several commercially available assays have been developed for point-of-care determination as well as for high-throughput automated laboratory platforms. Knowledge of preanalytic and analytic issues as well as sources of inter- and intraindividual variability in BNP and NT-proBNP is crucial for clinicians to allow correct interpretation of test results in routine practice. A few practical points for the clinical use of BNP and NT-proBNP include the following: Blood sampling may be performed without a standardized period of rest or posture. However, heavy physical exercise should be avoided before blood sampling. Blood for BNP determination must be collected in EDTA-coated plastic tubes, whereas for NT-proBNP serum or plasma collected in glass or plastic tubes is acceptable. Although the available assays for BNP correlate closely, owing to lack of assay standardization no two BNP assays are analytically equivalent at present. Therefore, reference and decision limits cannot be translated from one BNP assay to another. The stability of BNP is, to some extent, dependent on the assay used and requires refrigeration if samples are to be tested more than 4 h after sampling. NT-proBNP is stable for 2 d at room temperature. Because of

From: *Contemporary Cardiology:  
Cardiovascular Biomarkers: Pathophysiology and Disease Management*  
Edited by: David A. Morrow © Humana Press Inc., Totowa, NJ



analytic imprecision and biological variation, only NT-proBNP changes >25% from baseline and BNP concentration changes >40% correlate well with clinical course in follow-up of patients with heart failure. Erroneous test results with BNP or NT-proBNP assays are very rare but may occur from analytic inferences, such as the presence of fibrin strands or heterophilic antibodies and autoantibodies in patient samples.

**Key Words:** Natriuretic peptides; B-type natriuretic peptide; NT-proBNP; imprecision; interference; standardization; reference limit.

## INTRODUCTION

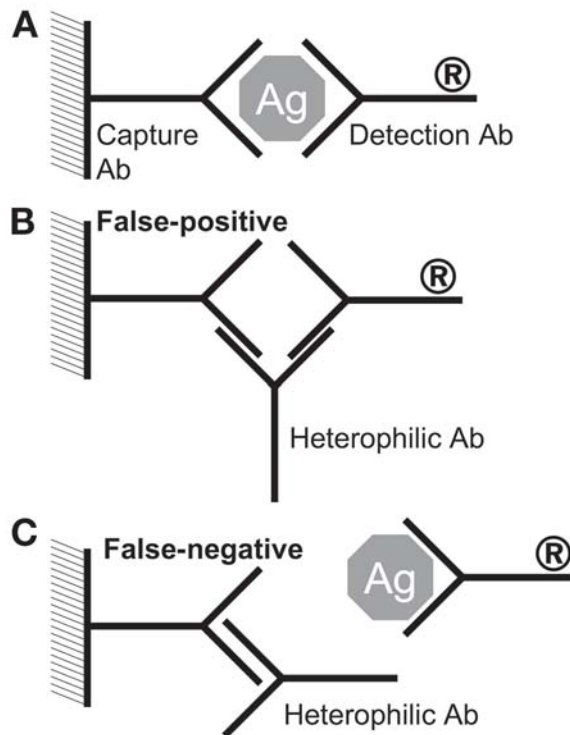
With the discovery of atrial natriuretic peptide (ANP) more than 20 yr ago, it became apparent that the heart is also an endocrine gland (1). The physiological effects and pathophysiology of the family of cardiac natriuretic peptides are described in detail elsewhere (see Chapter 21). Investigators soon recognized the potential for the natriuretic peptides to provide insight into cardiac function, and the development of specific radioimmunoassays for these peptides has enabled realization of this potential for a variety of research and clinical applications (2).

Because of greater in vitro stability and superior diagnostic performance in comparison with ANP, B-type natriuretic peptide (BNP) and the N-terminal fragment of its prohormone (NT-proBNP) have emerged as the preferred candidates for the diagnosis of heart failure, as well as other clinical applications. Several commercially available assays for BNP and NT-proBNP have been developed for point-of-care (POC) determination as well as for high-throughput automated laboratory platforms. The aim of this chapter is to provide clinicians and scientists with an understanding of the preanalytic and analytic issues that are critical for proper interpretation of testing for BNP or NT-proBNP in routine practice, as well as in research applications. With BNP and NT-proBNP becoming more heavily integrated into clinical practice as diagnostic and prognostic biomarkers, familiarity with differences between these markers and individual assay characteristics becomes particularly important.

## METHODS OF DETERMINATION: IMMUNOMETRIC (“SANDWICH”) ASSAYS

The commercially available assays for BNP and NT-proBNP are classified as immunometric assays. Such assays incorporate two antibodies that bind to different regions (epitopes) of the antigen to be detected (i.e., BNP or NT-proBNP) (Fig. 1A). One of these antibodies (capture antibody) is usually bound to a solid phase, and the second antibody (detection antibody) is labeled typically with an enzyme that catalyzes a reaction on which the detection of the antigen-antibody complex is based (e.g., fluorescence, luminescence). The immunometric “sandwich” assays typically offer a lower limit of detection, are more precise, and are frequently more specific than other types of assays, such as “competitive immunoassays,” thus making them the preferred type of assay (3).

The commercially available, fully automated assays for BNP and NT-proBNP require 15–20 min to measure the analyte but are typically associated with longer turnaround times when sample transport, processing, and reporting of results are included. As an alternative to central laboratory testing, POC whole-blood assays are available that provide results within 20 min (see also Chapter 32). As recommended for cardiac troponin, assays for BNP

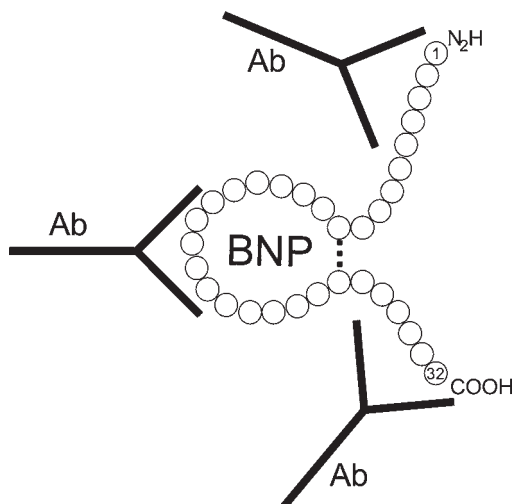


**Fig. 1.** Principle of immunometric (sandwich) assay with mechanisms of interference. (A) Normal situation. The capture antibody (Ab) is usually bound to a solid phase and binds the antigen to be detected (Ag). The detection antibody binds to a sterically remote region and is labeled with an enzyme that catalyzes the reaction on which the detection of the antigen-antibody complex is based. (B,C) Analytic interferences. Heterophilic antibodies may lead either to false positive test results by bridging between the detection and the capture antibody in the absence of the antigen or to false negative results by binding to the antigen-binding region of antibodies. Owing to steric hindrance, the antigen cannot bind to the antibodies although it is present in the sample.

and NT-proBNP should have a total imprecision of  $\leq 10\%$  at their medical decision limits, in order to avoid misclassifications owing to poor assay precision. Currently, most, but not all, commercially available BNP and NT-proBNP assays fulfill this criterion.

### *Issues for Assay Development*

It is essential that the binding characteristics (affinities) of the antibodies to the antigen not be altered when one of these two antibodies is already bound to the antigen. This objective is facilitated if the detected epitopes are not close in space. Because NT-proBNP is a larger molecule (8.5 kDa) than BNP (3.5 kDa), it was easier to design an immunometric assay with antibodies directed against sterically remote epitopes of the analyte. In addition to targeting epitopes that are sterically distant, the antibodies of an immunometric assay optimally should target epitopes that are stable, i.e., not subject to conformational changes or degradation that might interfere with binding of the antibody. Therefore, rational assay development should be based on a comprehensive knowledge of the structure, formation, degradation, as well as circulating forms of the analyte to be detected.



**Fig. 2.** Principle and antibody selection strategies of immunometric BNP assays.

The structure, formation, secretion, and degradation of BNP are well described; however, information on circulating products of degradation is limited. High-performance liquid chromatography (HPLC) of plasma samples reveals predominantly BNP 3-32, which is formed by proteolytic cleavage of serine and proline at the amino-terminal end of BNP 1-32, and small amounts of BNP 1-32 *in vivo* and *in vitro* (4). This modification may affect the affinity of antibodies that bind to epitopes at the amino-terminal end of the peptide and, thus, be responsible for variation in the stability of BNP as measured by different commercial assays (Fig. 2). To provide optimal results, BNP assays should have 100% crossreactivity with BNP 3-32. To date, no additional degradation products of BNP 1-32 have been found in plasma from patients with heart failure by HPLC analysis, and the carboxyl terminal appears to be stable (4,5).

In contrast to BNP, the metabolism and degradation of proBNP are poorly understood. It is not yet clear whether proBNP is split into NT-proBNP 1-76 and BNP only within cardiomyocytes, or whether this processing also occurs in serum (Fig. 3). Although split prohormone can be found in extracts of cardiomyocytes, intact proBNP has also been found in human blood, indicating that both proBNP and BNP are secreted by cardiac myocytes (6,7). Notably, a “high molecular mass” form of BNP with a molecular mass of approximately three times that of proBNP has also been detected by HPLC analysis of plasma from patients with heart failure (6,7). This finding suggests that proBNP circulates in plasma as a trimer. Although all NT-proBNP assays should in theory crossreact with proBNP, this assertion has not been tested directly owing to difficulty in synthesizing proBNP. Split products of the N-terminal portion of proBNP have been detected in circulating plasma as well.

### *Assays for BNP*

#### **DESCRIPTION OF ASSAYS**

At present, three assays for BNP (Biosite, Bayer, Abbott) are commercially available for use in the clinical laboratory. The assay manufactured by Biosite was developed as a quantitative POC test that has now also been licensed to be performed on an automated high-

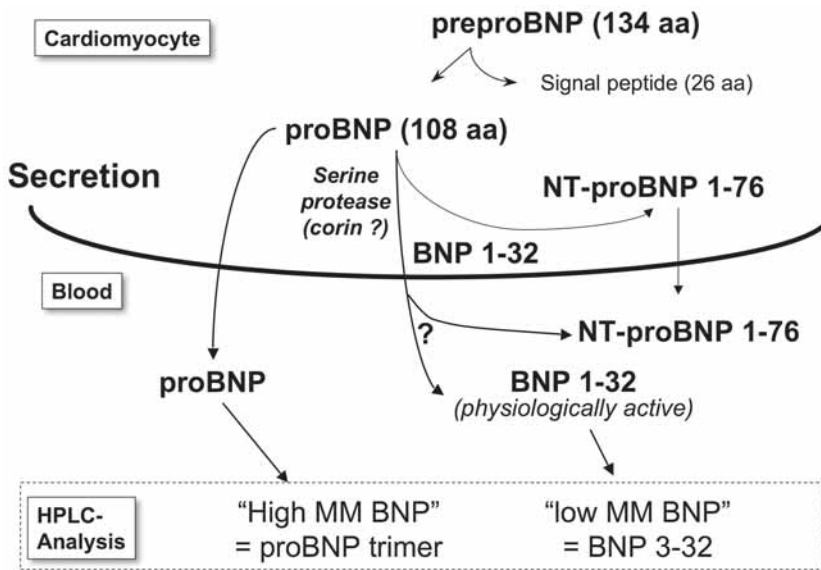


Fig. 3. Synthesis and secretion of BNP and proBNP. aa, amino acid; MM, molecular mass.

Table 1  
Antibody Characteristics of BNP Assays Cleared by the Food and Drug Administration

Manufacturer	Capture antibody	Detection antibody
Bayer/Shionogi	Murine MAb vs ring structure	Murine MAb vs C-terminus
Biosite/Beckman	Murine MAb vs ring structure <sup>a</sup>	Murine omniconal Ab <sup>a</sup>
Abbott	Murine MAb vs ring structure <sup>a</sup>	Murine MAb vs C-terminus

<sup>a</sup>Currently no exact information on epitope mapping on the BNP molecule is available from the manufacturers.

throughput platform (Access, Beckman Coulter). The assays manufactured by Bayer and Abbott are both for automated laboratory platforms. These immunometric assays for BNP are based on two monoclonal antibodies (MAbs) or a combination of monoclonal and omniconal antibodies. One antibody binds to the ring structure that is formed by a disulfide bond, and the other antibody binds to the carboxyl- or amino-terminal end, respectively (Fig. 2). Table 1 summarizes the antibody characteristics of the commercially available BNP assays.

#### CALIBRATION AND STANDARDIZATION

Each assay detects BNP without significant crossreactivity to related peptides (ANP, C-type natriuretic peptide [CNP], urodilatin, NT-proANP and NT-proBNP and fragments) or other peptide hormones. Because the synthesis of proBNP is very difficult, there are no published data regarding the affinity of these assays for the prohormone. Synthetic BNP is used as a calibrator for each of the commercial BNP assays. However, the source of the synthetic BNP varies among assay manufacturers, which makes standardization among assays more difficult. It is important for the clinician to recognize that, similarly to the circumstances for troponin I, the available assays for BNP are not standardized across manufacturers, and, thus, the concentration of BNP reported for the same sample may differ among assays (Table 2) (8–11). Nevertheless, there is acceptable concordance

Table 2  
Linear Correlation Coefficients and Regressions Among BNP Assays

<i>Manufacturer 1</i>	<i>Manufacturer 2</i>	<i>Correlation coefficient</i>	<i>Equation</i>
Biosite	Shionogi	0.96	Biosite = 1.58 ↔ Shionogi – 2.95 (10)
Biosite	Bayer	0.92	Bayer = 0.78 ↔ Biosite + 5.9 (8)
Biosite	Abbott	0.95	Abbott = 1.71 ↔ Biosite – 22.5 (11)
Bayer	Shionogi	0.98	Bayer = 1.11 ↔ Shionogi – 1.19 (8)
Abbott	Shionogi	0.94	Abbott (research assay) = 0.5 Shionogi + 1.22 (43) <sup>a</sup>
Abbott	Bayer	0.99	Abbott = 1.55 ↔ Bayer – 10.4 (44)

<sup>a</sup>Calibration of the research assay differs from the current routine assay.

of assays using a dichotomous decision limit recommended for the diagnosis of heart failure at 100 pg/mL. Owing to the lack of standardization, each assay must be validated separately. Moreover, the reference intervals and decision limits derived from clinical studies are valid only for the particular assay studied and should not be extrapolated to other BNP assays (9). It is therefore important for clinicians and laboratory staff to familiarize themselves with the assay employed in their practice, including the clinical studies on which its application is based.

### Assays for NT-proBNP

Commercially available assays for NT-proBNP do not crossreact with proANP, NT-proANP, fragments of NT-proANP, natriuretic peptides (ANP, BNP, CNP, urodilatin), or other peptide hormones. The crossreactivity with proBNP is unknown. The immunometric automated assay manufactured by Roche was the first to be approved for clinical application. The assay employs polyclonal antibodies that detect epitopes 1–21 and 39–50 of proBNP (12). Synthetic NT-proBNP 1–76, which is identical to human NT-proBNP 1–76 apart from minor modifications necessary to achieve sufficient in vitro stability, is used to calibrate the assay. Through licensing agreements, the Roche assay has been made available on other manufacturers' platforms (Dade-Behring, DPC) using the same antibodies and calibrator, as well as adapted as a POC assay.

Additionally, one competitive enzyme immunoassay is available in Europe. Its polyclonal antibodies are directed against epitope 8–29 of proBNP (9). This assay does not correlate closely ( $r = 0.73$ ) with the Roche assay and does not offer the ease of application, speed, sensitivity, and specificity of “sandwich” immunometric assays (9). Synx Pharma has developed an NT-proBNP POC assay (Nexus NT-proBNP). However, correlation coefficients and regression equations with the Roche assay have not yet been published. If only the Roche assay (or assays using the same antibodies) is widely used, harmonization of NT-proBNP assays—in contrast with BNP—will not present as an issue.

### BLOOD-SAMPLING CONDITIONS AND SAMPLE STABILITY

Understanding the critical issues of the preanalytic phase of sample collection is essential for the clinician because the results of testing for BNP and NT-proBNP are also influenced by factors occurring before the sample reaches the laboratory. Analytic causes of false results are comparably rare (*see* False Results).

### ***Blood-Sampling Conditions***

A standard protocol of extended rest in the supine position has been recommended prior to measurement of ANP. Owing to longer biological half-lives, BNP and particularly NT-proBNP are less susceptible than ANP to short-term fluctuations, such as during exercise and rapid changes in hemodynamics (e.g., caused by change in body posture or acute volume load). We previously reported a significant increase in BNP 3 min after ergometry in control subjects and patients with mild to moderate heart failure, but the relative increase from baseline values compared with ANP was small (13). Others have reported that BNP does not significantly increase after exercise stress testing in control subjects and patients with heart failure (14). Thus, in contrast to ANP, blood sampling for measurement of BNP may be performed without a standardized period of rest or position (15). Owing to a longer half-life of NT-proBNP, the requirements for blood sampling for measurement of NT-proBNP are even less critical than for BNP.

Drugs such as glucocorticoids, thyroid hormones, diuretics, ACE inhibitors,  $\beta$ -blockers, and adrenergic agonists may lower the plasma levels of natriuretic peptides. Treatment with diuretics results in a rapid drop in BNP and NT-proBNP. Therefore, blood samples intended to be used for the diagnosis of heart failure should ideally be drawn before the start of therapy. In stable chronic heart failure patients who are receiving optimized therapy, BNP and NT-proBNP concentrations may be unexpectedly low (16). As another example of confounding by treatment received, human recombinant BNP (nesiritide) is molecularly identical to endogenously released BNP and will be detected by immunoassays for BNP. Thus, BNP should not be measured for diagnostic or monitoring purposes during infusion of nesiritide. Two hours (i.e., more than five times the half-life) after discontinuation of the infusion, therapeutically administered BNP should no longer contribute to the measured BNP concentration. Exogenous BNP does not crossreact with assays for NT-proBNP.

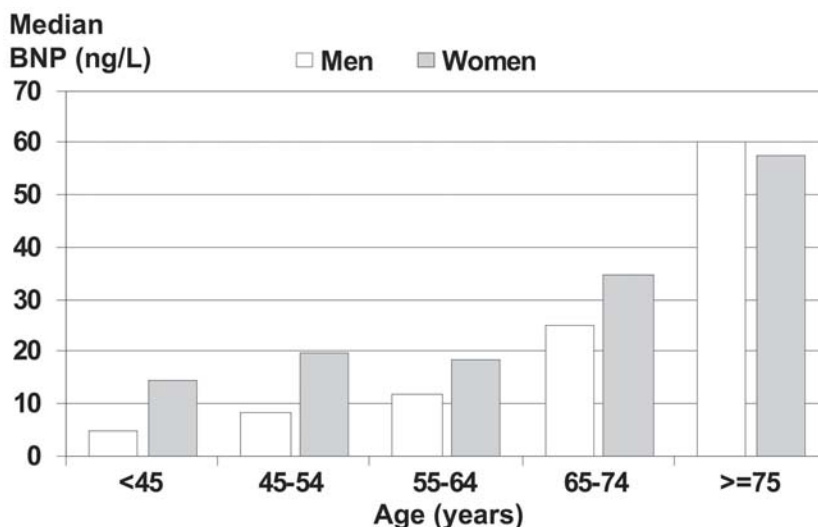
### ***Types of Sample***

EDTA anticoagulated whole blood or plasma samples collected in plastic tubes are optimal for measurement of BNP (17). Collection and storage in glass tubes results in incomplete recovery of BNP. Serum, heparin plasma, and EDTA plasma (values are 10% lower) are acceptable for determination of NT-proBNP, and glass tubes may be used (12). Presently, one system (Nexus NT-proBNP) allows measurement of NT-proBNP in whole blood.

### ***Sample Stability***

The *in vitro* stability of both BNP and NT-proBNP is sufficient for routine clinical use. The *in vitro* stability of BNP is dependent on the assay used for determination (see Issues for Assay Development). BNP is stable in EDTA *whole blood* at room temperature for 4 h (Biosite and Abbott assays), and at 4°C for 24 h (Bayer assay). EDTA *plasma* is stable at 4°C for 24 h (Abbott assay) and 48 h (Bayer assay). A significant decrease in plasma BNP concentrations was noted when BNP was measured after 24 h of storage at 4°C with the Biosite assay (12). If samples are not to be analyzed within several hours, it is recommended that the plasma be frozen at or below -20°C.

NT-proBNP is stable in whole blood or in EDTA or heparinized plasma samples for 2 to 3 d at room temperature (18,19). NT-proBNP is stable in serum samples if serum is separated from cells within 24 h. NT-proBNP is stable in serum or plasma samples for several days at 4°C and for 12 mo at or below -20°C (12,18,19).



**Fig. 4.** Influence of age and gender on BNP concentrations in a healthy adult reference population. Data are from the Bayer multisite trial (8).

## REFERENCE RANGES AND BIOLOGICAL VARIATION

### *Lack of Assay Standardization*

Owing to lack of assay standardization no generally applicable reference intervals for BNP can be defined at present. Currently, BNP reference and decision limits must be determined separately for each assay. Although assays for NT-proBNP are not yet standardized either, it is expected that the dependence of the most widely used assays on antibodies and calibrators from the same source will result in an acceptable agreement of reference ranges. In general, the concentrations of NT-proBNP are approx 20 times higher than those of BNP (12).

### *Age- and Gender-Related Differences*

Many studies report higher BNP and NT-proBNP concentrations in women, and a concurrent increase with age in both genders (*see* Fig. 4; 8,12,19–22). This variation by age and gender is mediated *in part* by mild renal impairment, left ventricular hypertrophy, and abnormal systolic and diastolic cardiac function (22). Nevertheless, studies that excluded subjects with any measurable renal dysfunction and even subtle evidence of diastolic dysfunction have shown age and gender differences in BNP and NT-proBNP to remain. The physiological basis for these differences is not yet clearly defined. However, observations from several settings provide some clues as to potential contributors. For example, there are no significant variations in BNP plasma concentrations throughout the menstrual cycle (23). However, increased plasma BNP levels have been reported in the last trimester of pregnancy and in the immediate puerperium (24). In healthy neonates, BNP and NT-proBNP concentrations are much higher than in adults (approx 10- to 20-fold) and are highest immediately after birth, descend through maturation, and reach adult levels at about 1 mo of age (25–27). This observation suggests a physiological role of BNP in the perinatal circulatory changes that lead to an increase in left ventricular

**Table 3**  
**Influence of Age and Gender**  
**on NT-proBNP Concentrations (ng/L)**  
**in a Healthy Adult Reference Population<sup>a</sup>**

Age (yr)	<i>NT-proBNP reference limit</i>	
	<i>Male</i>	<i>Female</i>
<40	<90	<140
40–60	<190	<280
60–75	<300	<300
>75	<450	<450

<sup>a</sup>Pooled data from the literature for the Roche assay (19,26,27).

volume and pressure load. Notably, there is no significant influence of gender on the plasma concentration of BNP in children <10 yr of age; the sex-related difference emerges in the second decade of life (26). Such findings implicate estrogen as contributing to the observed differences.

This disparity in the concentration of BNP between men and women and younger vs older individuals suggests that age- and gender-specific reference intervals should be used routinely to interpret BNP and NT-proBNP values; that is, a single cutoff value without adjustment for age and sex may not be optimal (Table 3). Normal reference limits (97.5th percentile) should be independently established for both BNP and NT-proBNP based on age (by decade) and by gender. Preliminary data indicate some ethnic differences in the concentration of natriuretic peptides. Thus, variation based on ethnicity needs to be further evaluated as a possible independent factor to be considered when interpreting BNP results. Based on limited data in the setting of acutely decompensated heart failure in which markedly increased BNP and NT-proBNP concentrations can be expected, a single decision limit is sufficiently accurate for the diagnosis of heart failure (28).

### ***Biological Variation***

A lack of understanding of the physiological and biological variability of BNP and NT-proBNP in patients with heart failure may result in clinicians misinterpreting changes (increases or decreases) in BNP and NT-proBNP concentrations in the context of disease monitoring and establishing the success or failure of therapy. Data on biological variation from carefully designed studies are limited and conflicting. In healthy subjects, BNP does not exhibit circadian variation when determined every third hour over 24 h (21). Similarly, there is no circadian variation in NT-proBNP. However, in some, but not all (21), studies, both BNP and NT-proBNP exhibit an intraindividual biological variability of 25–45% (29,30). Based on their data, Wu et al. (29) propose that relative changes on the order of 130% for BNP and 90% for NT-proBNP are necessary before results from two serially collected time points can be considered statistically significant. By contrast, others suggest that based on the analytic imprecision of available assays and more modest intraindividual variation of BNP and NT-proBNP, it is more reasonable to consider changes >25% from the baseline concentration as a real difference in serial measurements (30). Moreover, decreases in BNP >40% correlate well with clinical improvement and a decline in the mortality of patients with heart failure (31,32).



## FALSE RESULTS

As with other immunoassays, false-positive or false-negative BNP or NT-proBNP results are rare but may occur (33–35). Assays differ in their susceptibility to analytic interferences. Some analyzers may be particularly susceptible to the presence of particles (e.g., fibrin strands) or bubbles in the sample, thereby causing erroneous test results.

### *Interfering Antibodies*

Human antianimal (heterophilic) antibodies, rheumatoid factor, and autoantibodies in patients with autoimmune diseases are potential sources for false test results. Commercial assays include blocking agents to minimize these analytic interferences, but this method may not be effective in every situation. Exposure to animal antigens (e.g., close contact with animals or treatment with antibody fragments, such as abciximab) can give rise to human antianimal antibodies. The BNP and NT-proBNP assays are mainly based on mouse antibodies, and, therefore, human antimouse antibodies are most relevant to clinical practice. Heterophilic antibodies and autoantibodies may lead either to false positive test results, by bridging between the detection and the capture antibodies in the absence of the analyte, or to false negative results, by interfering with the binding of the assay antibodies (Fig. 1B,C). Heterophilic antibodies may persist for months to years after initial exposure.

### *Interfering Particles*

The presence of fibrin strands in serum that is processed for analysis prior to complete clot formation is known to cause errors in many immunoassay systems. The susceptibility of the different automated immunoassay analyzers to such interference varies. Fibrin strands are only of concern for NT-proBNP measurement when conducted using serum samples. Blood for BNP determination must be collected in EDTA-coated plastic tubes. EDTA is important for in vitro stabilization of BNP because it inhibits degradation by metalloproteases (36). NT-proBNP may also be measured using fresh plasma samples. If serum is used, it is important to ensure that the clotting process is complete prior to centrifuging the sample in order to eliminate the presence of microfibrin strands. Icteric and hemolyzed samples may also cause inaccuracy in immunoassays based on fluorimetric detection of the signal.

### *Other Conditions That Increase Natriuretic Peptides*

Concentrations of BNP and NT-proBNP may be elevated in settings other than acute heart failure. Such increases *do not* represent analytic false positives but may cause “false positive” clinical diagnostic results, if other etiologies for abnormal BNP results are not considered. Disease processes other than heart failure (e.g., renal and thyroid function) have been shown to influence the concentration of natriuretic peptides (37). As an example, hyperthyroidism increases and hypothyroidism decreases natriuretic peptide concentrations (38). Renal impairment has been shown to increase NT-proBNP concentrations substantially and BNP to a lesser extent (39,40). In severe renal impairment (glomerular filtration rate of  $<60$  mL/[min $\cdot$ 1.73 m $^2$ ]) and end-stage renal diseases, testing of BNP or NT-proBNP may be difficult to interpret because decision limits for the diagnosis of heart failure or risk stratification were developed almost solely in patients without significant renal dysfunction. Appropriate BNP and NT-proBNP reference intervals in these special populations should be established.

Obesity has also been reported to have an impact on BNP concentration in apparently healthy subjects and in patients with heart failure. Either an attenuation of BNP release or an increase in clearance may explain the inverse relationship between body mass index and BNP (41,42).

### *Managing Potential False Test Results*

False positive test results should be suspected in the setting of elevated BNP or NT-proBNP values that do not exhibit variation consistent with the clinical picture or the serial kinetics. Similarly to that for troponin, serial testing can be very valuable in discerning false test results. Analytic false positives resulting from poor sample handling will resolve with proper technique. Clinicians should consult with their laboratory if heterophilic antibodies or autoantibodies are suspected, and appropriate testing may be performed. In the vast majority of cases, “false positive” results are the consequence of other conditions leading to a rise in BNP concentration; thus, the clinician must always consider alternative diagnoses in this situation. False negative tests may be substantially more difficult to detect but fortunately are extremely rare. Obesity is the most common clinical setting in which the concentration of BNP and NT-proBNP may be significantly lower than expected despite the presence of heart failure.

## CONCLUSION

Clinicians and the laboratory community are excited about the potential of BNP and NT-proBNP for the diagnosis and management of cardiovascular disease. Knowledge of preanalytic and analytic issues as well as sources of inter- and intraindividual variability in BNP and NT-proBNP is crucial for clinicians to allow correct interpretation of test results in routine practice. A few practical points are important for the clinical use of BNP and NT-proBNP:

1. Blood sampling for BNP or NT-proBNP may be performed without a standardized period of rest or posture. However, heavy physical exercise should be avoided before blood sampling.
2. Blood for BNP determination must be collected in EDTA-coated plastic tubes, whereas for NT-proBNP collection of serum or plasma in glass or plastic tubes is acceptable.
3. Although the available assays for BNP correlate closely, owing to lack of assay standardization no two BNP assays are analytically equivalent at present. Therefore, reference and decision limits cannot be translated from one BNP assay to another. The practitioner must consider the assay used and the clinical evidence available based on the individual assay used in the laboratory. The majority of NT-proBNP assays are based on the same antibodies and calibrators and are expected to provide acceptable agreement of medical decision limits.
4. The stability of BNP is somewhat dependent on the assay used and requires refrigeration if samples are to be tested more than 4 h after sampling. NT-proBNP is stable for 2 d at room temperature.
5. In healthy individuals, BNP and NT-proBNP values are higher in women and increase with age in both men and women.
6. Because of analytic imprecision and biological variation only NT-proBNP changes >25% from baseline and BNP concentration changes >40% correlate well with clinical course in follow-up of patients with heart failure.

7. Erroneous test results with BNP or NT-proBNP assays are very rare but may occur from analytic inferences, such as the presence of fibrin strands or heterophilic antibodies and autoantibodies in patient samples.

## REFERENCES

1. de Bold AJ, Borenstein HB, Veress AT, Sonnenberg H. A rapid and potent natriuretic response to intravenous injection of atrial myocardial extracts in rats. *Life Sci* 1981;28:89–94.
2. Davies M, Espiner E, Geoff R, et al. Plasma brain natriuretic peptide in assessment of acute dyspnoea. *Lancet* 1994;343:440–444.
3. Clerico A, Del Ry S, Giannessi D. Measurement of cardiac natriuretic hormones (atrial natriuretic peptide, brain natriuretic peptide, and related peptides) in clinical practice: the need for a new generation of immunoassay methods. *Clin Chem* 2000;46:1529–1534.
4. Shimizu H, Masuta K, Aono K, et al. Molecular forms of human brain natriuretic peptide in plasma. *Clin Chim Acta* 2002;316:129–135.
5. Shimizu H, Aono K, Mausuta K, et al. Degradation of human brain natriuretic peptide (BNP) by contact activation of blood coagulation system. *Clin Chim Acta* 2001;305:181–186.
6. Shimizu H, Masuto K, Asada H, Sugita K, Sairenji T. Characterization of molecular forms of probrain natriuretic peptide in human plasma. *Clin Chim Acta* 2003;334:233–239.
7. Yandle TG, Richards AM, Gilbert A, Fisher S, Holmes S, Espiner EA. Assay of brain natriuretic peptide in human plasma: evidence for high molecular weight BNP as a major plasma component in heart failure. *J Clin Endocrinol Metab* 1993;76:832–838.
8. Wu AHB, Packer M, Smith A, et al. Analytical and clinical evaluation of the Bayer ADVIA Centaur automated B-type natriuretic peptide assay in patients with heart failure: a multisite study. *Clin Chem* 2004;50:867–873.
9. Hammerer-Lercher A, Ludwig W, Falkensammer G, et al. Natriuretic peptides as markers of mild forms of left ventricular dysfunction: effects of assays on diagnostic performances of markers. *Clin Chem* 2004;50:1174–1183.
10. Fischer Y, Filzmaier K, Stiegler H, et al. Evaluation of a new, rapid bedside test for quantitative determination of BNP. *Clin Chem* 2001;47:591–594.
11. Sorti S, Prontera C, Emdin M, et al. Analytical performance and clinical results of a fully automated MEIA system for BNP assay: comparison with a POCT method. *Clin Chem Lab Med* 2004;42:1178–1185.
12. Yeo KTJ, Wu AHB, Apple FS, et al. Multicenter evaluation of the Roche NT-proBNP assay and comparison to the Biosite Triage BNP assay. *Clin Chim Acta* 2003;338:107–115.
13. Friedl W, Mair J, Thomas S, Pichler M, Puschendorf B. Natriuretic peptides and cyclic guanosine 3',5'-monophosphate in asymptomatic and symptomatic left ventricular dysfunction. *Heart* 1996;76:129–136.
14. Krüger S, Graf J, Merx MW, et al. Brain natriuretic peptide kinetics during dynamic exercise in patients with chronic heart failure. *Int J Cardiol* 2004;95:49–54.
15. Boomsma F, Deinum J, van den Meiracker AH. Relationship between natriuretic peptide concentrations in plasma and posture during blood sampling. *Clin Chem* 2001;47:963–965.
16. Tang WHW, Girod JP, Lee MJ, et al. Plasma B-type natriuretic peptide levels in ambulatory patients with established chronic symptomatic systolic heart failure. *Circulation* 2003;108:2964–2966.
17. Shimizu H, Aono K, Masuta K, Asada H, Misaki A, Teraoka H. Stability of brain type natriuretic peptide in human blood samples. *Clin Chem Acta* 1999;285:169–172.
18. Karl J, Borgya A, Gallusser A, et al. Development of a novel, N-terminal-proBNP (NT-proBNP) assay with a low detection limit. *Scand J Clin Lab Invest* 1999;59(Suppl 230):177–181.
19. Collinson PO, Barnes SC, Gaze DC, et al. Analytical performance of the NT-proBNP assay on the Elecsys 1010 and 2010 analysers. *Eur J Heart Fail* 2004;6:365–368.
20. Raymond I, Groenning BA, Hildebrandt PR, et al. The influence of age, sex and other variables on the plasma level of NT-proBNP in a large sample of the general population. *Heart* 2003;89:745–751.
21. Jensen KT, Carsens J, Ivarsen P, Pedersen EB. A new fast and reliable radioimmunoassay of brain natriuretic peptide in human plasma: reference values in healthy subjects and in patients with different diseases. *Scand J Clin Lab Invest* 1997;57:529–540.
22. Sayama H, Nakamura Y, Saito N, Kinoshita M. Why is the concentration of plasma brain natriuretic peptide in elderly inpatients greater than normal? *Coron Artery Dis* 1999;10:537–540.

23. Maffei S, Clerico A, Iervasi G, et al. Circulating levels of cardiac natriuretic hormones measured in women during menstrual cycle. *J Endocrinol Invest* 1999;22:1–5.
24. Rutherford AJ, Anderson JV, Elder MG, Bloom SR. Release of atrial natriuretic peptide during pregnancy and immediate puerperium. *Lancet* 1987;I:928, 929.
25. Yoshiyoshi M, Kamiya T, Saito Y, et al. Plasma brain natriuretic peptide concentrations in healthy children from birth to adolescence: marked and rapid increase after birth. *Eur J Endocrinol* 1995; 133:207–209.
26. Koch A, Singer H. Normal values of BNP in infants, children, and adolescents. *Heart* 2003;89:875–878.
27. Mir ST, Marohn S, L  er M, et al. Plasma concentrations of NT-proBNP in control children from the neonatal to adolescent period and in children with congestive heart failure. *Pediatrics* 2002;110:1–6.
28. Knudsen CW, Riis JS, Finsen AV, et al. Diagnostic value of a rapid test for BNP in patients presenting with acute dyspnoea: effect of age and gender. *Eur J Heart Fail* 2004;6:55–62.
29. Wu AHB, Smith A, Wiecek S, et al. Biologic variation for N-terminal pro and B-type natriuretic peptides and implications for therapeutic monitoring of patients with congestive heart failure. *Am J Cardiol* 2003;92:628–631.
30. Nelzi dEriil GV, Tagnochetti T, Nauti A, et al. Biological variation of NT-proBNP in healthy individuals. *Clin Chem* 2003;49:1554, 1555.
31. Hammerer-Lercher A, Falkensammer G, Ludwig W, et al. A comparison of BNP and NT-proBNP in the disease monitoring of heart failure patients. *Clin Chem* 2003;49(S6):A65, 66.
32. Anand IS, Fisher LD, Chiang YT, et al. Changes in brain natriuretic peptide and norepinephrine over time and mortality and morbidity in the Valsartan Heart Failure Trial (Val-HeFT). *Circulation* 2003;107: 1278–1283.
33. Boscato LM, Stuart MC. Incidence and specificity of interference in two-site immunoassays. *Clin Chem* 1986;32:1491–1495.
34. Selby C. Interferences in immunoassays. *Ann Clin Biochem* 1999;36:704–721.
35. Kazmierczak SC, Catrou PG. Analytical interference—more than just a laboratory problem. *Am J Clin Pathol* 2000;113:9–11.
36. Belenky A, Smith A, Zhang B, et al. The effect of class-specific protease inhibitors on the stabilization of B-type natriuretic peptide in human plasma. *Clin Chim Acta* 2004;340:163–172.
37. Redfield MM, Rodeheffer RJ, Jacobsen SJ, et al. Plasma brain natriuretic peptide concentration: impact of age and gender. *J Am Coll Cardiol* 2002;40:976–982.
38. Clerico A, Emdin M. Diagnostic accuracy and prognostic relevance of the measurement of cardiac natriuretic peptide: a review. *Clin Chem* 2004;50:33–50.
39. Luchner A, Hengstenberg C, L  wel H, et al. N-terminal pro-brain natriuretic peptide after myocardial infarction—a marker of cardio-renal dysfunction. *Hypertension* 2002;39:99–104.
40. McCullough PA, Duc P, Omland T, et al. BNP and renal function in the diagnosis of heart failure: an analysis from the breathing not properly multinational study. *Am J Kidney Dis* 2003;41:571–579.
41. Wang TJ, Larson MG, Levy D, et al. Impact of obesity on plasma natriuretic peptide levels. *Circulation* 2004;109:594–600.
42. Mehra MR, Uber PA, Park MH, et al. Obesity and suppressed BNP levels in heart failure. *J Am Coll Cardiol* 2004;43:1590–1595.
43. Shih J, Matias M. Development of an ultra-sensitive BNP assay. Poster presented at 53rd AACC annual meeting, Chicago, 2001.
44. M  ller T, Gegenhuber A, Poelz W, Haltmayer M. Preliminary evaluation of the AxSYM B-type natriuretic peptide (BNP) assay and comparison with the ADVIA Centaur BNP assay. *Clin Chem* 2004;50: 1104–1106.



# 23

---

## Clinical Use of Natriuretic Peptides for the Diagnosis and Management of Heart Failure

---

*Alan Maisel, MD*

### CONTENTS

INTRODUCTION
BIOLOGY AND PHYSIOLOGY OF NATRIURETIC PEPTIDES
ANALYTIC AND ASSAY CHARACTERISTICS
BNP TESTING AND DIAGNOSIS OF SYMPTOMATIC HEART FAILURE
USE OF BNP FOR RISK STRATIFICATION IN HEART FAILURE
SCREENING FOR VENTRICULAR DYSFUNCTION
USE OF BNP FOR INPATIENT MANAGEMENT OF HEART FAILURE
TOWARD THE FUTURE: USE OF NATRIURETIC PEPTIDES FOR TARGETING THERAPY
CONCLUSION
REFERENCES

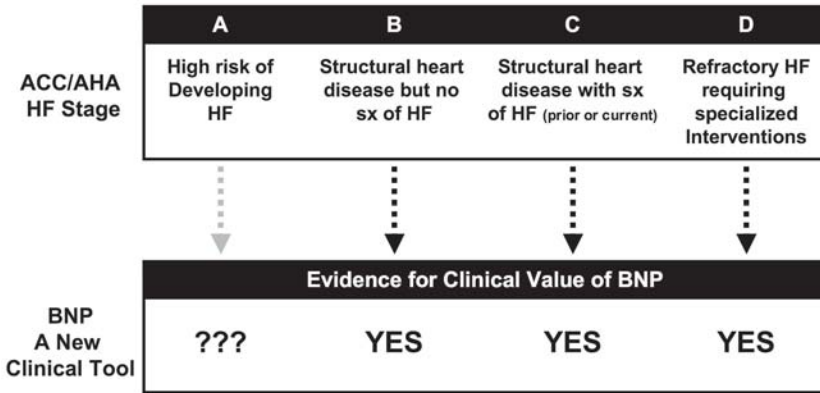
---

### SUMMARY

Since the approval of B-type natriuretic peptide (BNP) as an aid to the diagnosis of heart failure by the US Food and Drug Administration in November 2000, this novel biomarker has generated intense interest for both clinical and research applications in patients with or at risk of heart failure. Initially focused on the urgent, bedside diagnosis of heart failure, BNP testing in settings outside of the emergency department has been supported by subsequent research. Not only is BNP a useful adjunct for diagnosing and monitoring patients with heart failure (stages C and D), but studies now suggest that BNP provides independent prognostic information with respect to the risk of death or rehospitalization. In addition, BNP may have a role in screening high-risk patients for the presence of underlying cardiac dysfunction (stages A and B). BNP is established as a useful tool for aiding the diagnosis and risk stratification of patients with heart failure. In addition, the potential for using BNP in screening, in monitoring, and as a target for therapy continues to be explored.

**Key Words:** Natriuretic peptides; B-type natriuretic peptide; NT-proBNP; heart failure; diagnosis; prognosis.

From: *Contemporary Cardiology:  
Cardiovascular Biomarkers: Pathophysiology and Disease Management*  
Edited by: David A. Morrow © Humana Press Inc., Totowa, NJ



**Fig. 1.** ACC/AHA classification of heart failure stages and potential application of BNP. HF, heart failure; Sx, symptoms.

### INTRODUCTION

Since its approval by the US Food and Drug Administration in November 2000 as an aid to the diagnosis of heart failure, the novel biomarker B-type natriuretic peptide (BNP) has generated intense interest for both clinical and research applications in patients with or at risk of heart failure. With up to 70% of all hospitals in the United States using BNP testing, it is important for the clinician to have a firm grasp of the evidence and issues related to its application (1). Figure 1 illustrates the new American College of Cardiology/American Heart Association (ACC/AHA) heart failure staging system and the potential value of BNP testing in each of the four stages. Initially focused on the urgent, bedside diagnosis of heart failure, BNP testing in settings outside of the emergency department (ED) has been supported by subsequent research. BNP is not only a useful adjunct for diagnosing and monitoring patients with heart failure (stages C and D); studies now suggest that BNP provides independent prognostic information regarding the risk of death or rehospitalization. Furthermore, there may be a role for BNP in screening high-risk patients for the presence of underlying cardiac dysfunction (stages A and B) (2–4). This chapter provides an up-to-date distillation of the current and proposed application of BNP as a biomarker for diagnosis, prognosis, screening, and treatment monitoring in patients with or at risk of heart failure.

The incidence and prevalence of heart failure continue to increase steadily in the United States (Fig. 2). Approximately 61 million Americans (almost one-fourth of the population) live with cardiovascular disease, of which 4.7 million are symptomatic heart failure patients. This number is expected to increase to an estimated 10 million in 2037, thus making heart failure disease a leading cause of premature, permanent disability in the workforce (5,6). The cost of managing heart failure is estimated at \$56 billion/yr, 70% of which results from hospitalization. In a study of 17,000 survivors of hospitalization for heart failure, almost 50% were readmitted within 6 mo, and close to 16% were readmitted two or more times (7).

### BIOLOGY AND PHYSIOLOGY OF NATRIURETIC PEPTIDES

In addition to being an extremely effective pump, the human heart is an important endocrine organ that functions together with other physiological systems to control fluid homeo-

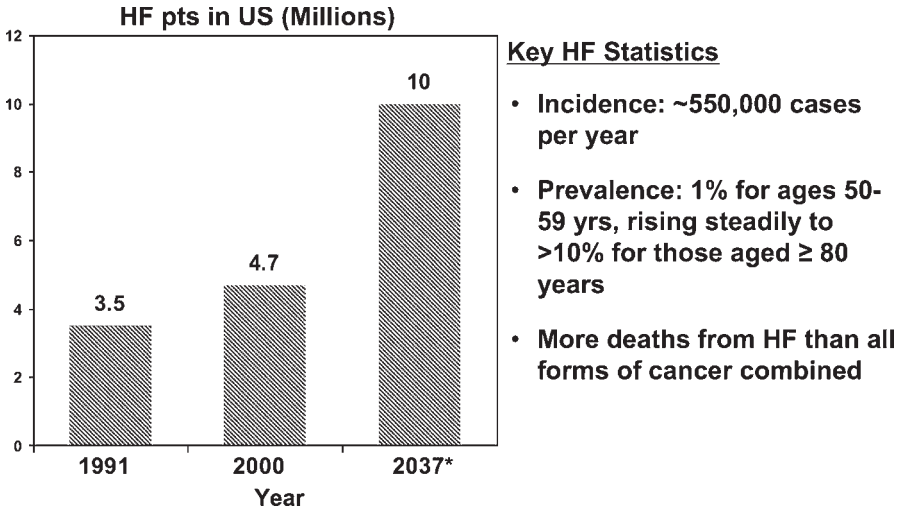


Fig. 2. Prevalence of heart failure (HF) in United States. \*Expected increase. (Data from refs. 5,6.)

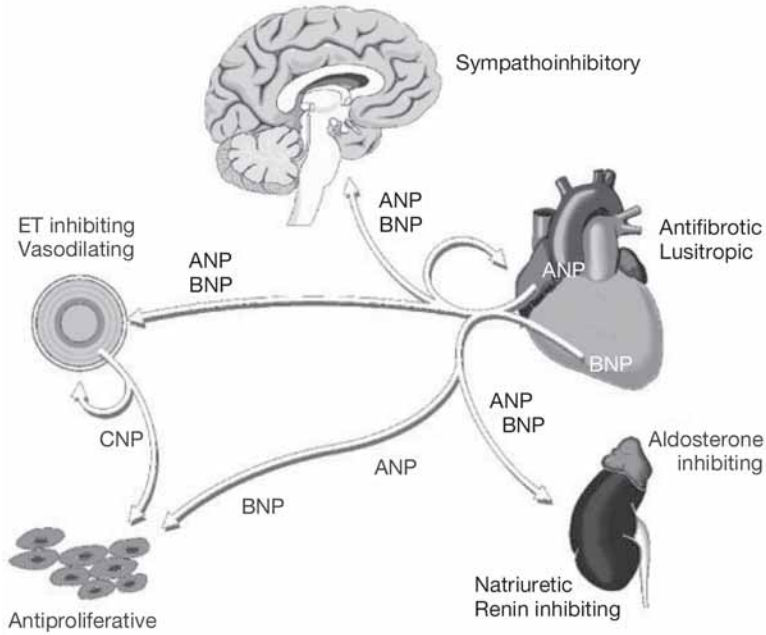


Fig. 3. Actions of natriuretic peptide system. ET, endothelin; CNP, C-type natriuretic peptide. (Reproduced from ref. 65, with permission.)

stasis. Cells of the heart synthesize a family of structurally related peptide hormones, collectively termed the *natriuretic peptides*, that include atrial natriuretic peptide (ANP) and brain or BNP. The biology of this family of proteins is described in detail in Chapter 21. The natriuretic peptides are released in response to wall stretch, ventricular dilation, and/or increased pressures, all resulting from fluid overload (8), and exert powerful diuretic, natriuretic, and vascular smooth muscle relaxing actions (Fig. 3). These hormones are also natural antagonists for the sympathetic nervous system and the renin–angiotensin–



aldosterone axis (8–10). The main physiological role of the natriuretic peptides is to protect the cardiovascular and other systems from the effects of volume overload.

## ANALYTIC AND ASSAY CHARACTERISTICS

Analytic issues important to the clinical use of BNP are discussed in Chapter 22. A few practical points are worth reiterating here:

- Either central laboratory instrumentation or point-of-care (POC) testing systems are acceptable.
- When interpreting natriuretic peptide results, one needs to consider carefully laboratory and biological variation, including that related to sex, obesity, and renal function.
- The results of natriuretic testing are dependent on the type of test. Cut points for N-terminal proBNP (NT-proBNP) and BNP are *not* interchangeable. Moreover, different assays for BNP may also differ with respect to values reported for the same sample. A list of clinically available assays for BNP is provided in Table 1.

## BNP TESTING AND DIAGNOSIS OF SYMPTOMATIC HEART FAILURE

### *Role of BNP Levels in Diagnosis of Heart Failure in ED Settings*

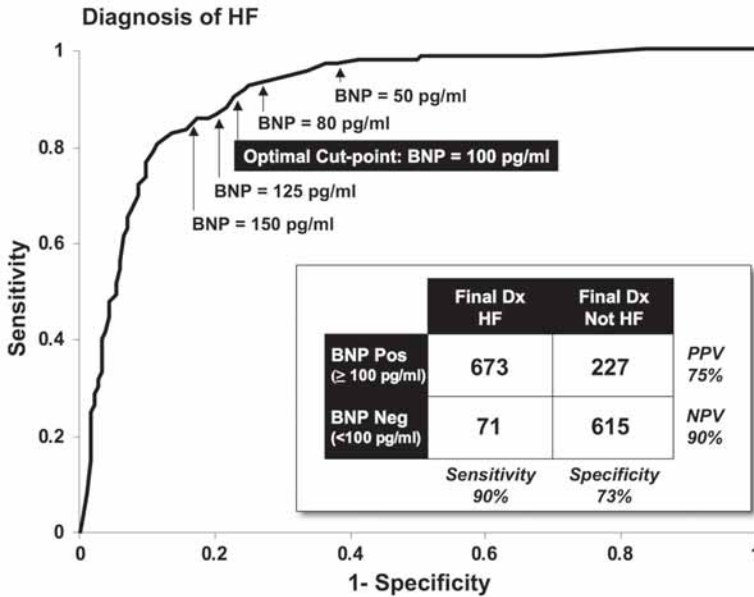
Although substantial advances have been made in the understanding of the pathophysiology and treatment of heart failure, diagnosis of the disease remains difficult. For the acutely ill patient presenting to the ED with dyspnea, an incorrect diagnosis carries the consequence of higher risk of morbidity and mortality (11). Therefore, the diagnosis of heart failure in emergency settings must be rapid and accurate. Unfortunately, the signs and symptoms of heart failure are nonspecific (12). Dyspnea may also be a nonspecific finding in the elderly or obese patient in whom comorbidity with respiratory disease and physical deconditioning are common (13). Routine laboratory results, electrocardiograms (ECGs), and X-rays are also often insufficient to make the appropriate diagnosis (13–16).

Strong and consistent data establish the value of BNP for facilitating the diagnosis of heart failure in patients presenting with dyspnea. Davis et al. (17) first measured levels of the natriuretic hormones ANP and BNP in 52 patients presenting with acute dyspnea and found that the plasma concentration of BNP more accurately reflected the final diagnosis than did ejection fraction or the plasma concentration of ANP. Dao et al. (18) were the first to use a rapid POC BNP assay to evaluate patients presenting to an urgent-care center with dyspnea ( $n = 250$ ). The evaluating physicians were asked to make an assessment of the probability of heart failure (low, medium, or high) for each patient and were blinded to the results of BNP measurements. The finding that the BNP results were the strongest predictor of the diagnosis of heart failure was the basis for the design of the Breathing Not Properly study, the first large-scale, prospective study using BNP testing to evaluate the cause of dyspnea.

The Breathing Not Properly Multinational Study enrolled 1586 patients who presented to the ED with acute dyspnea (19). The blood concentration of BNP was measured on arrival. On completion of their evaluation, the ED physicians (blinded to BNP) were asked to assess the probability of the patient having heart failure. In addition, two independent cardiologists also blinded to the BNP levels later reviewed all clinical data and standardized scores to produce a clinical diagnosis that was used as the “gold standard” for this study. In the analysis of diagnostic performance, the concentration of BNP used

**Table 1**  
**Clinically Available Assays for BNP**

<i>Manufacturer</i>	<i>Assay/platform</i>	<i>Method</i>	<i>Imprecision total % CV</i>	<i>Dynamic range (pg/mL)</i>	<i>Cut point for heart failure (pg/mL)</i>
Abbott	AxSYM (BNP)	Microparticle enzyme immunoassay	6.5–9.4	0–4000	100
Bayer Healthcare Diagnostics	ADVIA Centaur (BNP)	Chemiluminescent sandwich immunoassay	2.3–4.7	0–5000	100
Biosite	Triage (BNP)	Single-use fluorescence immunoassay device	9.9–12.2	0–5000	100
Biosite	Beckman Access (BNP)	Two-site chemiluminescent sandwich immunoenzymatic assay	2.1–6.7	0–5000	100
Roche	Elecsys (NT-proBNP)	Electrochemiluminescent immunoassay	3.6–5.8	0–35,000	125 (<75 yr); 450 (≥75 yr)

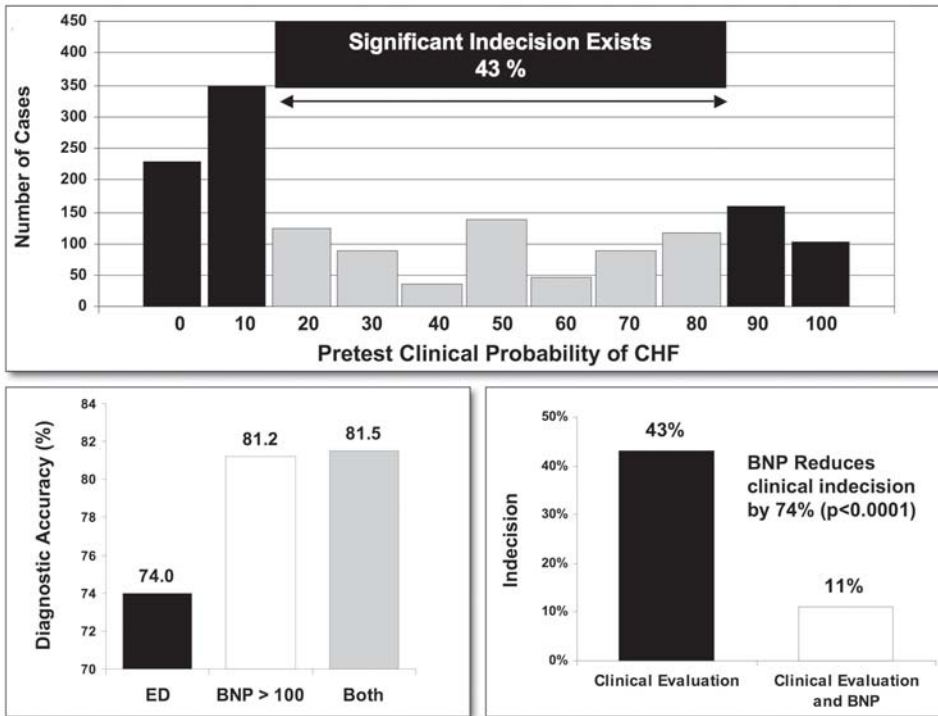


**Fig. 4.** Receiver operating characteristic (ROC) analysis of BNP as diagnostic test for heart failure among patients presenting with dyspnea and enrolled in Breathing Not Properly Multinational Study. HF, heart failure; Dx, diagnosis. (Data from ref. 19.)

alone was a more accurate predictor of the presence or absence of heart failure than any historical or physical findings or other laboratory values. The concentration of BNP was significantly higher in patients with heart failure than in those with noncardiac dyspnea (675 vs 110 pg/mL). A BNP cutoff value of 100 pg/mL provided a sensitivity of 90% and a specificity of 76% for differentiating heart failure from other causes of dyspnea, and a cutoff level of 50 pg/mL had a negative predictive value (NPV) of 96% (Fig. 4). Moreover, the addition of BNP to the physician's traditional clinical tools reduced the rate of indecision regarding the diagnosis from 43 to 11% (Fig. 5). In multivariable analysis, measurement of BNP contributed to the diagnosis, even after taking into account features of the history and physical examination.

### ***Using BNP Levels to Triage Patients Presenting With Acute Dyspnea***

Measurement of BNP helps to make the diagnosis of heart failure in the ED and may also assist in triage decisions, such as in identifying those patients who should be admitted directly vs those who might be treated and then discharged. In The Rapid Emergency Department Heart Failure Outpatient Trial (20) in 464 patients presenting to the ED with complaints of difficulty breathing, BNP measurements were performed on arrival, and then every 3 h in the ED, at the time of hospital admission, and at discharge. Physicians were informed only whether the initial BNP level was greater or less than 100 pg/mL and were blinded to subsequent BNP results. Notably, patients discharged from the ED had a higher median concentration of BNP than those admitted to the hospital (976 vs 766 pg/mL). Approximately 90% of all patients were admitted to the hospital. Of those admitted, 11% had BNP levels <200 pg/mL, indicative of less severe heart failure. Mortality for these patients was 0% at 30 d and only 2% at 90 d. Of the patients discharged from the ED, 78% had BNP levels >400 pg/mL. At 90 d, the mortality in this group was 9%. There were no



**Fig. 5.** (A) Frequency distribution of pretest assessment of heart failure by emergency physicians in patients presenting with dyspnea and enrolled in Breathing Not Properly Multinational Study; (B) accuracy of physician's diagnosis using all available tools except BNP, BNP alone, or the two combined; (C) rate of indecision based on clinical evaluation alone or using BNP. (Data from ref. 19.)

deaths through 90 d in patients discharged with a BNP <400 pg/mL. The results of this study demonstrated discordance between the perceived severity of heart failure by ED physicians and severity as determined by BNP. Thus, BNP testing in this setting may assist physicians in triaging patients, and making decisions regarding initial treatment.

The BASAL Study (21) evaluated the cost-effectiveness of BNP testing for guiding both the ED evaluation and in-patient management of patients with heart failure. Investigators randomly assigned patients presenting to the ED with dyspnea to undergo either a single measurement of BNP or no such measurement. Participating clinicians were advised that a level of BNP <100 pg/mL made the diagnosis of heart failure unlikely, whereas a level >500 pg/mL made it highly likely. For intermediate levels, the use of clinical judgment and adjunctive testing was encouraged. In this single-blind trial of 452 patients, rapid measurement of BNP in the ED was associated with a 10% decrease in the rate of hospital admission, a reduction in the median length of stay by 3 d, and a reduction in the mean total cost of treatment by approx \$1800 (26% decrease), with no adverse effect on the risk of death or subsequent hospitalization. Because the study was performed in Switzerland, the data regarding length of hospitalization and costs might not be directly applicable to the United States. Nevertheless, this carefully performed trial suggests that the use of BNP in the emergency evaluation of acute dyspnea can improve both the efficiency and the quality of care by reducing the use of hospital resources and associated costs by eliminating the need for other, more expensive tests, or by establishing an alternative diagnosis that does not require hospitalization.

Table 2  
Other Conditions Influencing Interpretation of BNP

*Renal insufficiency*

- BNP is increased in patients with chronic renal insufficiency (eGFR < 60); however it is still useful for the diagnosis of heart failure using a higher cut point, especially when baseline BNP levels are known. The relationship between NT-proBNP levels is less clear, although patients with renal insufficiency often have high levels of NT-proBNP.

*Pulmonary disease*

- Lung disease that results in pulmonary hypertension and right ventricular pressure or volume overload can lead to elevated BNP levels (usually in the range of 100–500 pg/mL).
- A high BNP level is associated with worse prognosis in several of these settings.
- BNP may be a useful screening test for patients with lung disease and associated cardiac risk factors, because many of these patients have underlying cardiac disease. A low BNP in this setting effectively rules out cardiac dysfunction.

*Obesity*

- Because patients with heart failure and obesity may have lower levels of BNP for any given NYHA functional class, low levels of BNP should be interpreted with caution.
- An obese patient with established heart failure can be followed for decompensation if baseline BNP levels are known.

### ***Comorbidity and Special Issues That Influence Interpretation of BNP***

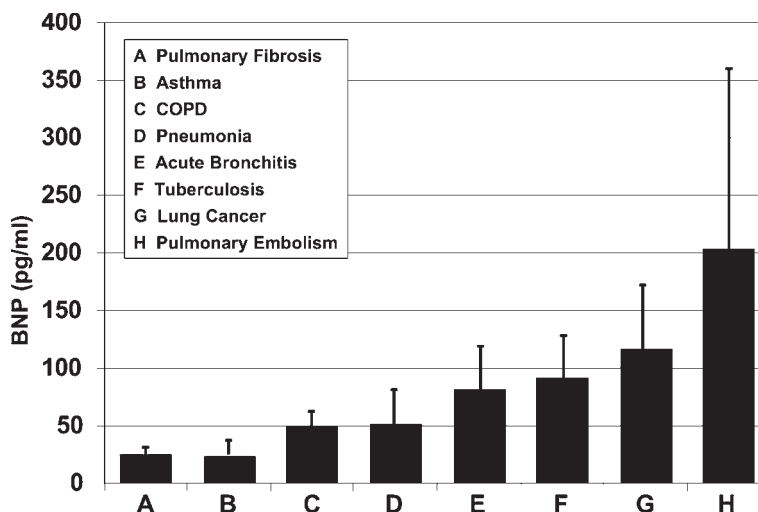
#### **RENAL INSUFFICIENCY**

The Breathing Not Properly Multinational Study and other observational studies have demonstrated a correlation between estimated glomerular filtration rate (eGFR) and BNP in patients with and without heart failure (22). Findings from this study indicated that the concentration of BNP should not be interpreted in isolation but should be integrated with other findings in the diagnostic evaluation. Chronic kidney disease influences the optimal threshold for BNP in the diagnosis of heart failure. In general, as the stage of chronic kidney disease advances, a higher cut point of BNP is required to maintain specificity. For example, a cut point of 200 pg/mL is reasonable for those with an eGFR <60 mL/(min·1.73 m<sup>2</sup>). Despite the presence of renal dysfunction, BNP maintains a high level of diagnostic utility with an area under the ROC curve of >0.80 across all chronic kidney disease groups (Table 2).

The mechanism(s) underlying the higher concentration of BNP in patients with chronic kidney disease are not yet completely elucidated. It is possible that reduced renal blood flow in acute heart failure can result in increases in serum creatinine and, hence, a falsely lower eGFR. In addition, chronic volume overload owing to chronic kidney disease with or without heart failure can increase left ventricular (LV) hypertrophy and wall tension, thus stimulating secretion of BNP. In fact, multiple studies of systolic heart failure have demonstrated a decreased survival with reduced baseline eGFR (23).

#### **PULMONARY DISEASE**

The presence of concomitant pulmonary disease does not diminish the utility of the BNP test in distinguishing patients with heart failure from those without heart failure. Morrison et al. (24) showed that rapid testing of BNP could differentiate pulmonary from cardiac etiologies of dyspnea. Some types of pulmonary disease that provoke significant increases in wall stress in the right heart, such as cor pulmonale, lung cancer, and pulmonary embolism (PE), are associated with elevated levels of BNP. However, the magnitude



**Fig. 6.** Concentration of BNP in patients with pulmonary disease. COPD, chronic obstructive pulmonary disease.

of increase is typically less than that for patients with dyspnea from heart failure (Fig. 6). In a substudy of the Breathing Not Properly Multinational Study (25), among 417 subjects with a history of asthma or chronic obstructive pulmonary disease without prior heart failure, 21% were newly discovered to have heart failure. Only 37% of these new cases were identified by physicians in the ED, whereas a concentration of BNP >100 pg/mL identified 93%. Additionally, a level of BNP >100 pg/mL has been shown to provide diagnostic information beyond that obtained from individual chest radiographic indicators (26).

Because BNP levels appear to correlate with pulmonary capillary wedge pressure and are helpful in differentiating heart failure from lung disease, measurement of BNP may be of value in differentiating noncardiogenic from cardiogenic pulmonary edema (27). For example, when BNP levels were obtained in 35 patients with acute respiratory distress syndrome (ARDS) and in 42 patients hospitalized for severe dyspnea with the diagnosis of heart failure, the median level of BNP in patients with heart failure (773 pg/mL) was significantly higher than for patients with ARDS (123 pg/mL;  $p < 0.001$ ). The area under the ROC curve using BNP to differentiate heart failure from ARDS was 0.90 (0.83–0.98;  $p < 0.001$ ). At a cut point of 360 pg/mL, BNP provided 90% sensitivity, 86% specificity, 89% positive predictive value (PPV), and 94% NPV (accuracy: 88%) for the discrimination of ARDS vs heart failure. Thus, BNP may prove useful as an alternative to invasive hemodynamic monitoring in some settings.

Increased plasma concentrations of BNP are also present in some patients with large pulmonary emboli and are associated with poor prognosis (28). Similarly, plasma levels of BNP are closely related to the degree of functional impairment of patients with primary pulmonary hypertension and parallel the severity of pulmonary hemodynamic changes (29). It is speculated that serial measurements of BNP may improve the management of these patients.

### DIASTOLIC DYSFUNCTION

Like systolic ventricular dysfunction, diastolic (or nonsystolic) dysfunction is also associated with an increased concentration of BNP (30,31). In the Breathing Not Properly

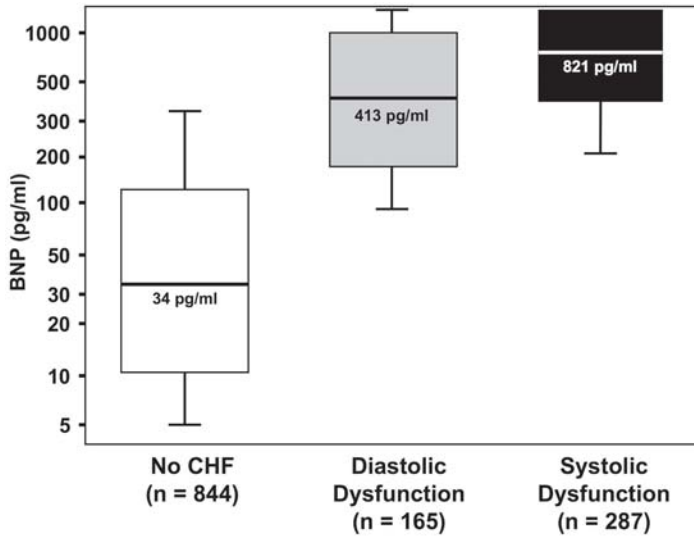


Fig. 7. Concentration of BNP in patients with diastolic heart failure. (Data from ref. 32.)

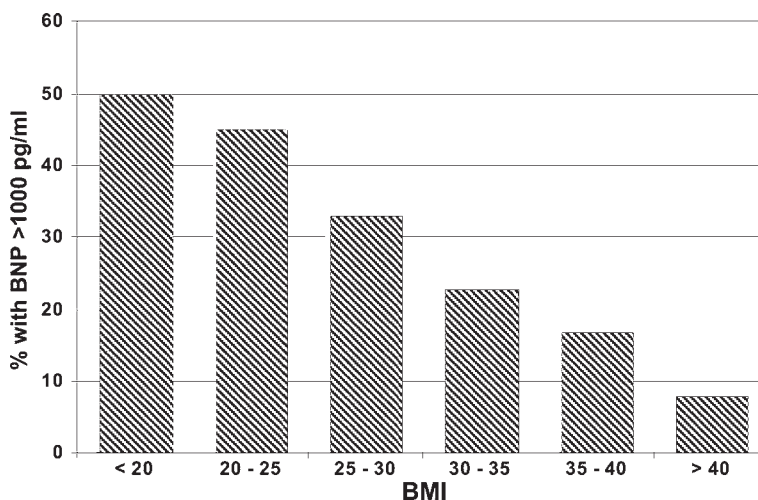
study, BNP levels in patients with diastolic dysfunction were roughly 50% of the median concentration for patients with systolic dysfunction (Fig. 7) (32). A number of studies have described the detection of diastolic dysfunction using BNP. For example, Lubien et al. (30) assessed BNP levels in 294 patients referred for echocardiography. Patients found to have evidence of LV diastolic dysfunction ( $n = 119$ ) had a mean BNP concentration of  $286 \pm 31$  pg/mL compared with  $33 \pm 3$  pg/mL in the group without LV dysfunction ( $n = 175$ ). Patients with restrictive-like filling patterns on echocardiography had the highest levels of BNP ( $408 \pm 66$  pg/mL), and patients with symptoms had higher BNP levels in all diastolic filling patterns. The area under the ROC curve for BNP to detect any diastolic dysfunction was 0.92 (0.87–0.95;  $p < 0.001$ ). A BNP value of 62 pg/mL had a sensitivity of 85%, a specificity of 83%, and an accuracy of 84% for detecting diastolic dysfunction when systolic function was normal. In the future, drug trials for treating patients with diastolic dysfunction may use BNP concentrations as an inclusion criterion as well as an end point for treatment success.

## OBESITY

Obesity is a strong risk factor for the development of heart failure (33), yet obesity can interfere with the usual diagnostic approaches, including the physical examination, chest X-ray, and echocardiography (34,35). Thus, BNP has the potential to play an important role as an adjunct to the diagnosis of heart failure in this challenging population. However, interpretation of BNP results in this setting requires special consideration. Mehra et al. (36) were the first to demonstrate that there is a significant inverse relationship between BMI and the plasma concentration of BNP. Mehra's data are supported by similar findings from the Breathing Not Properly Multinational Study (37) (Fig. 8). Notably, only 8–24% of patients with heart failure and a BMI  $>30$  kg/m<sup>2</sup> had BNP levels  $>1000$  pg/mL.

## Practical Recommendations for Use of BNP in Evaluation of Acute Dyspnea

Measurement of BNP is of proven diagnostic utility in the evaluation of patients with acute dyspnea. Thus, in new patients presenting with dyspnea, a history, a physical exam-



**Fig. 8.** Relationship between frequency of marked elevation in BNP (>1000 pg/mL) and BMI.

ination, a chest X-ray, and an ECG should be undertaken together with laboratory measurements that include BNP. Current data suggest the following guidelines:

1. Because levels of BNP rise with age and are affected by gender, comorbidity, and drug therapy, do not use the BNP value in isolation from the clinical context.
2. If the BNP level is <100 pg/mL, heart failure is highly unlikely (NPV 90%).
3. If the BNP level is >500 pg/mL, heart failure is highly likely (PPV 90%).
4. For BNP levels between 100 and 500 pg/mL, also consider the following possible etiologies:
  - Stable LV dysfunction.
  - Right ventricular failure from cor pulmonale.
  - Acute PE.
  - Renal failure.
5. Patients may present with heart failure with normal or unexpectedly low levels of BNP in the following circumstances:
  - Flash pulmonary edema (<1 to 2 h).
  - Etiology of heart failure at the level of left atrium (e.g., acute mitral regurgitation from papillary muscle rupture).
  - Obesity (BMI >35).

There is often a discrepancy between the physician's perception of illness and the severity indicated by BNP. The complementary information available from BNP may help to determine objectively the severity of congestive heart failure and therefore be useful to triage decisions. Patients with a BNP <200 pg/mL who are otherwise stable (e.g., no acute coronary syndrome) probably do not warrant admission.

### USE OF BNP FOR RISK STRATIFICATION IN HEART FAILURE

BNP is a valuable marker for risk stratification in the setting of heart failure. In a study of 78 patients referred to a heart failure clinic, BNP showed a significant correlation to the heart failure survival score (38). In addition, changes in the plasma concentration of BNP were related to changes in the limitation of physical activities and were associated with the likelihood of deterioration in functional status. As such, BNP levels reflect New



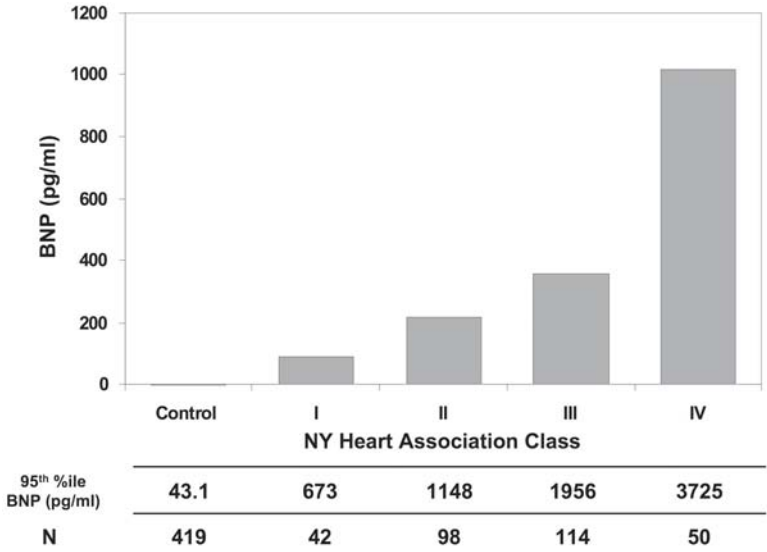


Fig. 9. Correlation of BNP with NYHA class. (Data from ref. 66.)

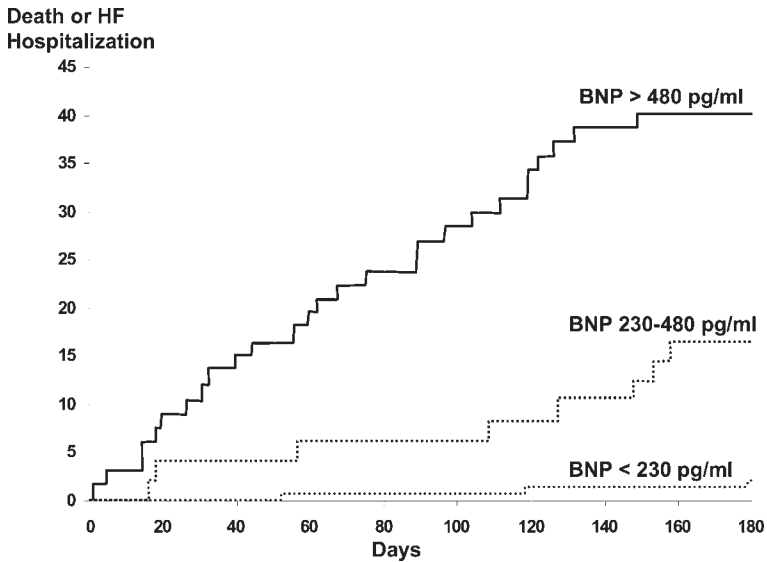


Fig. 10. Risk of death or rehospitalization for heart failure stratified by BNP measured at time of visit to ED with dyspnea. (From ref. 39, with permission.)

York Heart Association (NYHA) functional classification (Fig. 9). Harrison et al. (39) followed 325 patients for 6 mo after an index visit to the ED for dyspnea. Higher levels of BNP were associated with a progressively worse prognosis (Fig. 10). The relative risk (RR) of 6-mo heart failure admission or death in patients with BNP levels >230 pg/mL was 24 times the risk for patients with lower levels.

***BNP and Prognosis in Hospitalized Patients***

Cheng et al. (40) followed the daily levels of BNP in 72 patients admitted with decompensated heart failure and the relationship to 30-d death or readmission. Patients with high

BNP levels at both the time of admission and discharge were most likely to experience a recurrent cardiac event. Specifically, only 16% of patients with a fall in BNP levels during hospitalization had a subsequent cardiac event, whereas 52% of those with rising BNP levels during treatment either were readmitted or experienced cardiac death. Patients with a concentration of BNP that declined to  $<430$  pg/mL had a reasonable likelihood of not being readmitted within the following 30 d. These observations regarding the value of serial determinations of BNP were supported by a similar study in which failure of BNP to decline over the hospitalization was associated with a higher risk of death/rehospitalization, whereas discharge levels  $<250$  pg/mL were indicative of high event-free survival (41).

### ***BNP and Prediction of Sudden Cardiac Death***

Several studies suggest that the level of BNP, perhaps by reflecting ventricular dilatation and stretch, may indicate risk of ventricular arrhythmias and sudden cardiac death. In a study of 452 ambulatory patients with mild to moderate heart failure (NYHA functional classes I and II) and LV ejection fraction  $<35\%$ , the level of BNP was independently associated with the risk of sudden cardiac death (42). Only 1% (1 of 110) of patients with BNP  $<130$  pg/mL died suddenly compared with 19% (43 of 227) of patients with BNP levels  $>130$  pg/mL. In addition, small studies have shown that the concentration of BNP falls when cardiac resynchronization therapy (CRT) is initiated and rises when CRT is subsequently deactivated (43,44).

### ***Association of BNP With Cardiac Troponin I in Heart Failure***

There is increasing evidence that myocyte necrosis and apoptosis contribute to progressive LV dysfunction in heart failure (45). Several studies have reported release of cardiac troponin in patients with decompensated heart failure in the absence of acute coronary syndrome or coronary artery disease (46). Moreover, BNP and troponin appear to offer complementary information with respect to prognosis (47).

## **SCREENING FOR VENTRICULAR DYSFUNCTION**

The success of a population-based screening program for a disease condition is dependent on several factors, including the prevalence of disease; the availability of a reliable screening test that is safe and inexpensive; proven effective treatment for the disease; and the availability of, and compliance with, follow-up care of individuals who have disease.

Given its high sensitivity, measurement of BNP is an attractive strategy to exclude LV systolic dysfunction in individuals with “normal” results. However, good diagnostic tests may not be optimal screening tests. In symptomatic patients, a test with a high sensitivity is critical because the consequences associated with missing a diagnosis are typically substantial. However, in the screening of asymptomatic patients, a high specificity is of increased importance because of the costs and risks associated with unnecessary additional testing and incorrect diagnosis (48).

### ***Population-Based Screening***

A study from the MONICA (MONitor trends In CARDiac disease) cohort assessed the performance of BNP for identifying LV dysfunction in 1252 community-based patients 25–74 yr of age (49). A plasma concentration of BNP  $>17.9$  pg/mL was found to have a sensitivity of 76% and a specificity of 87% for LV dysfunction as defined by an ejection

fraction <30%. The NPV was 97%, but the PPV was only 16%. Moreover, in a cohort of 2177 participants from the Framingham study, measurement of BNP was not useful in discriminating LV hypertrophy or systolic dysfunction, suggesting limited usefulness of BNP as a population-screening tool. Because of the low prevalence of disease as well as age- and gender-related changes in BNP levels, screening low-risk populations is not likely to yield good results.

However, the same investigators examined the long-term prognostic importance of the levels of BNP in asymptomatic middle-aged persons in the Framingham Offspring Study (3). After adjusting for traditional risk factors, the level of BNP was independently associated with the risk of death, heart failure, atrial fibrillation, and stroke over a mean follow-up period of 5 yr. A concentration of BNP >80th percentile in this cohort (20 pg/mL) was associated with a >60% increase in the long-term risk of death.

### *Screening in Higher-Risk Populations*

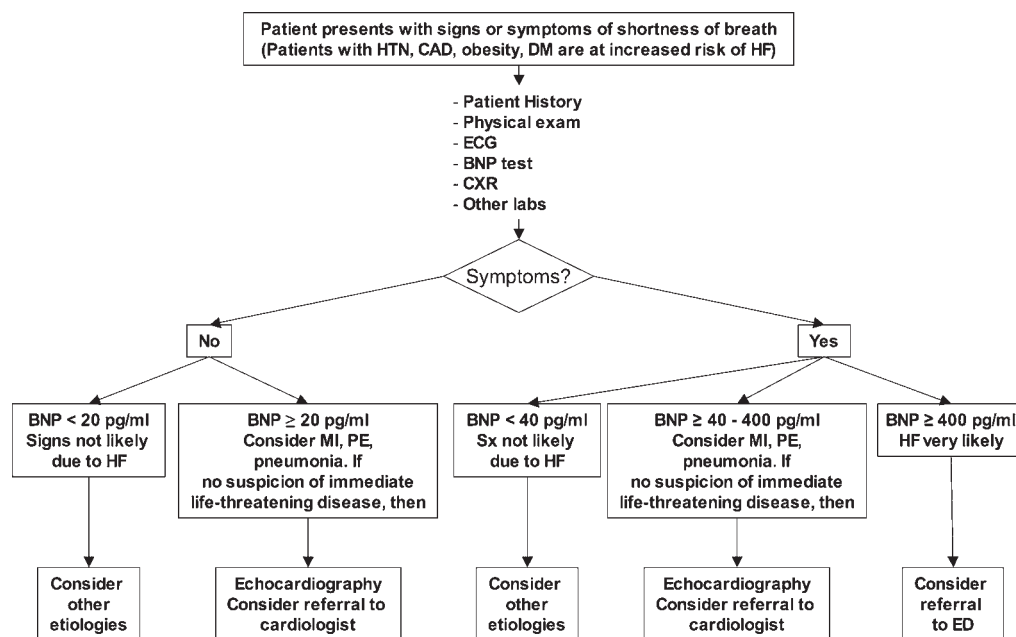
Using traditional cut points, Silver and Pisano (50) found a high incidence of elevated levels of BNP in an unselected at-risk population in a community-based setting. Along with other emerging evidence, this observation suggests that BNP may serve as a viable screening tool to detect patients progressing from stage A to stage B in the natural history of heart failure (Fig. 1).

In the Hillingdon Heart Failure Study, one-third of patients referred with a new diagnosis of heart failure to a rapid-access clinic by a primary care physician had the diagnosis confirmed (51). The diagnostic value of the plasma BNP concentration compared very favorably with the clinical opinion of an expert panel. The area under the ROC curve for diagnosis based on plasma BNP was 0.96. A diagnostic threshold of 22 pmol/L (76.4 pg/mL) combined a very high NPV (98%) with an acceptable PPV (70%). Thus, the findings of this study suggest a potential for BNP to improve the efficiency of referring patients with suspected heart failure for further assessment.

Epshteyn et al. (52) found that in high-risk but asymptomatic patients with diabetes, a BNP result >40 pg/mL detected underlying systolic and diastolic dysfunction. Only rare and mild cases of cardiac dysfunction (mainly diastolic) are evident in patients with BNP levels <20 pg/mL (53). At least one study has supported the screening strategy with BNP using a cutoff of 24 pg/mL followed by echocardiography for those with elevated levels as cost-effective for men older than 60 yr, and possibly for women with a  $\oplus$ 1% prevalence of at least moderate LV systolic dysfunction (54).

### *Recommendations Regarding Use of BNP for Screening*

At this time, there is insufficient evidence to support BNP testing for screening asymptomatic, low-risk populations for LV systolic dysfunction. There may be some role for BNP to screen high-risk subgroups such as patients with prior myocardial infarction, patients with diabetes, or those with an extended history of uncontrolled hypertension. However, echocardiography is likely to remain the primary method of assessing LV function in this setting. Figure 11 depicts one possible algorithm for BNP testing in the outpatient setting (55). This algorithm is framed around a lower cut point of 20 pg/mL and an intermediate cut point of 40 pg/mL. Patients with values above the cut points of 20 and 40 pg/mL should be referred for echocardiography with consideration of evaluation by a cardiovascular specialist.



**Fig. 11.** Algorithm for using BNP in primary care setting. (Adapted from ref. 50.) HF, heart failure; CAD, coronary artery disease; DM, diabetes mellitus; HTN, hypertension; CXR, chest X-ray; Sx, symptoms.

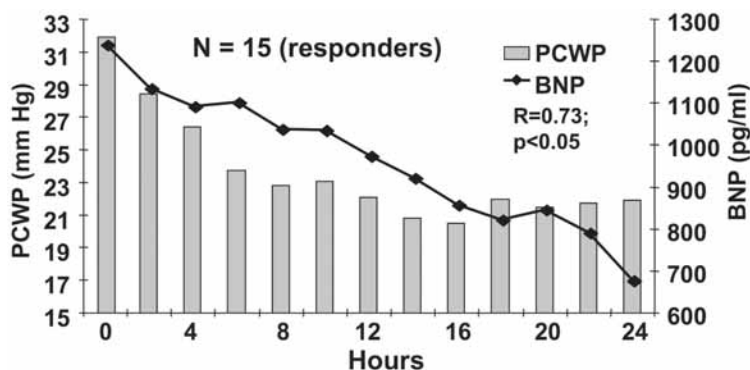
## USE OF BNP FOR INPATIENT MANAGEMENT OF HEART FAILURE

There are approx 1 million admissions annually to US hospitals for heart failure. Patients admitted to the hospital with decompensated heart failure often have improvement in symptoms with the various treatment modalities available. However, readmission after hospitalization for heart failure is surprisingly common, estimated at 44% at 6 mo within the Medicare population, and challenging to predict (56). Considering that hospitalization is the principal contributor to the cost of patient care (70–75% of the total direct costs) (57), a reduction in heart failure hospitalizations would reduce morbidity for the patient as well as costs to society.

The use of BNP for targeting treatment of patients with heart failure is under active investigation. Targeting treatment of disease to specific biomarkers has precedent: treatment of hypertension is targeted to blood pressure, diabetes to blood glucose, and dyslipidemia to lipid levels. The fact that BNP has a short half-life; is conveniently measured; and is a surrogate for wedge pressure, volume, NYHA functional class, and prognosis suggests its potential as a guide to therapy in heart failure.

### *Does High BNP Always Mean High Filling Pressure?*

Because a major stimulus for the release of BNP is increased wall tension, BNP levels might be expected to correlate with elevated LV filling pressures. However, in the clinical setting there are circumstances in which a high level of BNP is not associated with high left heart filling pressures. These situations include right-sided failure secondary to advanced pulmonary disease, PE, or primary pulmonary hypertension; acute or chronic renal failure; and rapid lowering of the wedge pressure with diuretics and/or vasodilators before



**Fig. 12.** Concurrent measurement of PCWP and BNP in patients with acute heart failure admitted to intensive care unit. Data are limited to responders to therapy as assessed using PCWP. (From ref. 58, with permission.)

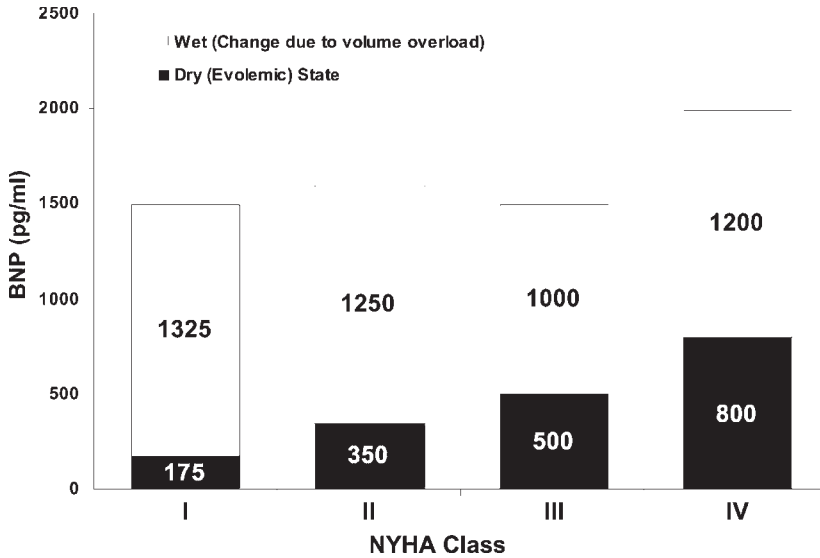
a Swan-Ganz catheter is placed. In addition, under some circumstances, BNP levels might be normal when the wedge pressure is high. This situation is most likely to occur in acute mitral regurgitation in which the increase in capillary pressure is “upstream” from the left ventricle and in “flash” pulmonary edema in which BNP might not have had time to be synthesized.

In a given patient, the level of BNP does not always correlate tightly to wedge pressure. However, in a patient admitted with heart failure and high filling pressures secondary to volume overload, along with a high BNP (“wet BNP”), a treatment-induced decrease in wedge pressure will almost always be associated with a rapid drop in BNP concentration, as long as the patient is maintaining adequate urine output. Kazanegra et al. (58) obtained hemodynamic measurements (pulmonary capillary wedge pressure [PCWP], cardiac output, right atrial pressure, systemic vascular resistance), and BNP levels every 2–4 h for the first 24 h and every 4 h for the next 24–48 h in patients admitted for decompensated heart failure. PCWP dropped from  $33 \pm 2$  to  $25 \pm 2$  mmHg over the first 24 h, whereas BNP dropped from  $1472 \pm 156$  to  $670 \pm 109$  pg/mL (Fig. 12). The correlation between BNP levels and other indices of cardiac function—cardiac output (thermodilution), mixed venous oxygen saturation, and systemic vascular resistance was nonsignificant. It should be emphasized that patients with end-stage heart failure admitted for transplant workup who are not acutely volume overloaded may not show a drop in BNP levels as the wedge pressure is lowered (“dry BNP”).

### *Wet and Dry BNP Levels*

We have proposed that the blood concentration of BNP in a patient who is admitted with decompensated heart failure comprises two components: a baseline, euvolemic, “dry” BNP level and a BNP level occurring from acute pressure or volume overload (“wet” BNP). At the point of decompensation, the sum of baseline BNP plus the additional production of BNP from ventricular stress owing to acute volume overload will determine the plasma concentration of BNP (Fig. 13).

The lower the “dry” BNP level, the less likely that the patient will require early rehospitalization. A low level of BNP (<200–300 pg/mL) correlates with NYHA functional class II and is indicative of a patient who is more likely to be in a true euvolemic state. Knowing a patient’s baseline level of BNP at dry weight is likely to be useful in moni-



**Fig. 13.** Illustration of potential contribution of volume overload to measured levels of BNP. See text for details.

		<b>Congestion at Rest</b>	
		<b>NO</b>	<b>YES</b>
<b>Low Perfusion at Rest</b>	<b>NO</b>	BNP = 100 - 400 <b>Warm &amp; Dry</b>	BNP = >600 <b>Warm &amp; Wet</b>
	<b>YES</b>	BNP = 400 - 1000 <b>Cool &amp; Dry</b>	BNP = >1000 <b>Cool &amp; Wet</b>

**Fig. 14.** Strategy for triage and therapy of patients with acutely decompensated heart failure. (Adapted from ref. 59.)

toring the patient for the first 30 days after discharge. Early elevations in BNP over baseline soon after discharge may trigger the need for more vigorous diuresis, or additional vasodilators.

Stevenson (59) has published a simple categorization of hemodynamic status to guide treatment with diuretics, vasodilators, or inotropic agents. I have updated this assessment by adding BNP ranges to this risk stratification scheme (Fig. 14). Patients who are admitted to the hospital with either new-onset or decompensated heart failure are usually volume overloaded. Treatment of this group includes diuretics and vasodilators. In our experience, almost all of these patients have BNP levels >600 pg/mL. In fact, if BNP levels are less than this, the severity of volume overload should be reevaluated. Diuretics, inotropes, and vasopressors are often indicated when patients are classified as “wet and cold.” These

patients frequently have BNP levels  $>1000$  pg/mL. Patients who are “cold and dry” have increased levels of BNP owing to systolic dysfunction, but often the level of BNP is not increased to the same magnitude as in patients who are “cold and wet.”

### ***How Often Should a BNP Level Be Obtained in the Hospital?***

There is no single correct answer to the frequently asked question, How often should a BNP level be obtained in the hospital? I obtain a BNP level at admission, after 24 h of treatment, and at discharge. Failure of BNP levels to fall in a 24-h period may identify a high-risk patient who is not responding to the initial treatment strategies. More frequent samples may be useful if there is a major clinical change or if being used in lieu of invasive monitoring. In patients who have been treated with nesiritide (BNP), exogenous BNP should be cleared within 2–6 h following discontinuation of the infusion. BNP levels can be measured at that time. If one wishes to monitor endogenous BNP during treatment, the fact that the half-life of nesiritide is 15–20 min and that the therapeutic effect lasts from 2 to 4 h can be utilized to help guide the clinician.

### ***What if a BNP Level Does Not Fall During Treatment?***

There may be several explanations why an elevated concentration of BNP does not fall with treatment in some patients with heart failure. For example, the high level of BNP may actually be the patient’s “dry” BNP level and will not be acutely lowered with diuretics or vasodilators. These patients tend to be NYHA functional class IV and have a poor prognosis.

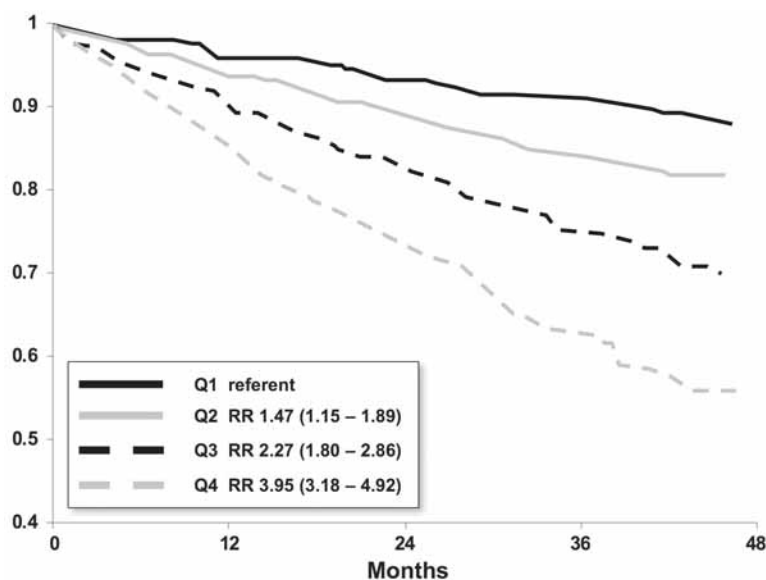
Patients who have high BNP levels that do not respond to treatment may be considered for other more aggressive strategies such as cardiac transplantation or the use of ventricular assist devices. In a trial of patients who received ventricular assist devices, the level of BNP declined as remodeling of the heart occurred, and an early decrease in BNP plasma concentration was indicative of recovery of cardiac function during mechanical circulatory support (60). Patients with high BNP levels at discharge are at increased risk and should be considered for early follow-up and/or home nursing visits.

Other reasons underlying persistent elevation of BNP include worsening of prerenal azotemia with diuresis, and large amounts of extravascular fluid (e.g., massive ascites) that must be mobilized. Finally, acute, severe pressure or volume overload might turn on the transcription of the mRNA for BNP to such a degree that even on initial lowering of the wedge pressure BNP levels might still be increasing.

## **TOWARD THE FUTURE:**

### **USE OF NATRIURETIC PEPTIDES FOR TARGETING THERAPY**

Perhaps the best approach toward keeping a patient with heart failure out of the hospital is to avoid recurrent volume overload manifest by increases above the level of BNP at discharge. Early after discharge, a rise in the level of BNP is often associated with volume overload and may prompt an increase in the dosing of diuretics. As is the practice at several institutions (61), when a patient comes to an urgent-care center with recurrent symptoms, BNP is measured. If there is no difference from baseline values, decompensation is unlikely. Because BNP is not a stand-alone test, it should be used in conjunction with other features of the examination, clinical history, and testing. In my experience, clinical features of decompensation along with an increase of 50% or more from baseline are often associated with worsening of heart failure.



**Fig. 15.** Survival stratified by quartile of change in BNP with therapy in Val-HeFT Trial. (From ref. 67, with permission.)

BNP may also be useful for guiding the selection of therapy. The Australia-New Zealand Heart Failure Group analyzed plasma neurohormones for prediction of adverse outcomes and response to treatment in 415 patients with LV dysfunction randomly assigned to receive carvedilol or placebo (62) and found that BNP was the best predictor of a benefit from carvedilol. In a randomized trial of 69 patients allocated to NT-proBNP-guided treatment vs symptom-guided therapy (63), patients receiving NT-proBNP-guided therapy had greater use of heart failure medications; lower levels of NT-proBNP; and a reduced incidence of cardiovascular death, readmission, and new episodes of decompensated heart failure. This study has prompted a number of larger studies including the multi-center Rapid Assessment of Bedside BNP In Treatment of Heart Failure trial.

It also appears that treatment with angiotensin-converting enzyme (ACE) inhibitors, angiotensin receptor blocker agents, spironolactone, and perhaps  $\beta$ -blockers reduces levels of BNP. In the Valsartan Heart Failure Trial (Val-HeFT), changes in BNP over time induced by pharmacological therapy were shown to correlate with subsequent morbidity and mortality (Fig. 15) (64). Patients with the greatest percentage decrease in BNP and norepinephrine from baseline had the lowest morbidity and mortality, whereas patients with the greatest percentage increase in BNP and norepinephrine were at greatest risk.

It is my practice to aim for BNP levels <200–300 pg/mL with standard therapy of ACE inhibitors and  $\beta$ -blockers and diuretics. Patients with BNP levels between 200 and 500 pg/mL are often NYHA functional class II/III and may require increased dosing of diuretics, especially spironolactone. Patients who despite standard medical treatment have advanced symptoms along with high BNP levels (400–600 pg/mL) may be candidates for continuous and palliative outpatient infusions of inotropes or vasodilators. In addition, biventricular pacing (if QRS is >120–130 ms) cardiac transplantation or LV assist device might be considered. In the future, stem cell or gene therapy may have a role in the treatment of these patients.



## CONCLUSION

BNP is established as a useful tool for aiding the diagnosis and risk stratification of patients with heart failure. In addition, the potential for using BNP in screening, in monitoring, and as a target for therapy continues to be explored.

## REFERENCES

1. <http://www.biosite.com/products/bnp.aspx>.
2. Mark DB, Felker GM. B-type natriuretic peptide: a biomarker for all seasons. *N Engl J Med* 2004;350:718–720.
3. Wang TJ, Larson MG, Levy D, et al. Plasma natriuretic peptide levels and the risk of cardiovascular events and death. *N Engl J Med* 2004;350:655–663.
4. Hunt SA, Baker DW, Chin MH, et al. ACC/AHA guidelines for the evaluation and management of chronic heart failure in the adult: executive summary: a report of the American College of Cardiology/American Heart Association Task Force on Practice Guidelines (Committee to revise the 1995 Guidelines for the Evaluation and Management of Heart Failure). *J Am Coll Cardiol* 2001;38:2101–2113.
5. Rich M. Epidemiology, pathophysiology, and etiology of congestive heart failure in older adults. *J Am Geriatr Soc* 1997;45:968–974.
6. Krumholz HM, Wang Y, Parent EM, et al. Quality of care for elderly patients hospitalized with heart failure. *Arch Intern Med* 1997;157(19):2242–2247.
7. Cohn JN, Levine TB, Olivari MT, et al. Plasma norepinephrine as a guide to prognosis in patients with chronic congestive heart failure. *N Engl J Med* 1984;311:819–823.
8. Clerico A, Iervasi G, Mariani G. Clinical relevance of the measurement of cardiac natriuretic peptide hormones in humans. *Horm Metab Res* 1999;31:487–498.
9. Maisel A. B-type natriuretic peptide levels: a potential novel “white count” for congestive heart failure. *J Card Fail* 2001;7:183–193.
10. Boomama F, Van der Meiracker AH. Plasma A- and B-type natriuretic peptides: physiology, methodology and clinical use. *Cardiovasc Res* 2001;51:442–449.
11. The SOLVD Investigators. Effect of enalapril on mortality and the development of heart failure in asymptomatic patients with reduced ventricular ejection fractions and congestive heart failure. *N Engl J Med* 1991;325:293–302.
12. Stevenson LW. The limited availability of physical signs for estimating hemodynamics in chronic heart failure. *JAMA* 1989;261:884–888.
13. Devereux RB, Liebson PR, Haran MJ. Recommendations concerning use of electrocardiography in hypertension and general population research. *Hypertension* 1987;9(2 Pt 2):II97–II104.
14. Wuerz RC, Meador SA. Effects of prehospital medications on mortality and length of stay in HF. *Ann Emerg Med* 1992;21(6):669–674.
15. Deveraux RB, Liebson PR, Horan MJ. Recommendations concerning use of echocardiography in hypertension and general population research. *Hypertension* 1987;9(2 Pt 2):II97–II104.
16. Davie AP, Francis CM, Love MP, et al. Value of the electrocardiogram in identifying heart failure due to left ventricular systolic dysfunction. *BMJ* 1996;312:222.
17. Davis M, Espiner E, Richards G, et al. Plasma brain natriuretic peptide in assessment of acute dyspnea. *Lancet* 1994;343:440–444.
18. Dao Q, Krishnaswamy P, Kazanegra R, et al. Utility of B-type natriuretic peptide (BNP) in the diagnosis of HF in an urgent care setting. *J Am Coll Cardiol* 2001;37:379–385.
19. Maisel A, Krishnaswamy P, Nowak RM, et al. Rapid measurement of B-type natriuretic peptide in the emergency diagnosis of heart failure. *N Engl J Med* 2002;347(3):161–167.
20. Maisel A, Hollander JE, Guss D, et al. Primary results of the Rapid Emergency Department Heart Failure Outpatient Trial (REDHOT). A multicenter study of B-type natriuretic peptide levels, emergency department decision making, and outcomes in patients presenting with shortness of breath. *J Am Coll Cardiol* 2004;44:1328–1333.
21. Mueller C, Scholer A, Laule-Kilian K, et al. Use of B-type natriuretic peptide in the evaluation and management of acute dyspnea. *N Engl J Med* 2004;350:647–654.
22. McCullough PA, Duc P, Omland T, et al. B-type natriuretic peptide and renal function in the diagnosis of heart failure: an analysis from the Breathing Not Properly Multinational Study. *Am J Kidney Dis* 2003;41(3):571–579.

23. Dries DL, Exner DV, Domanski MJ, et al. The prognostic implications of renal insufficiency in asymptomatic and symptomatic patients with left ventricular systolic dysfunction. *J Am Coll Cardiol* 2000;35: 681–689.
24. Morrison KL, Harrison A, Krishnaswamy P, et al. Utility of a rapid B-natriuretic peptide (BNP) assay in differentiating HF from lung disease in patients presenting with dyspnea. *J Am Coll Cardiol* 2002;39: 202–209.
25. McCullough PA, Hollander JE, Nowak RM, et al. Uncovering heart failure in patients with a history of pulmonary disease: rationale for the early use of B-type natriuretic peptide in the emergency department. *Acad Emerg Med* 2003;10(3):198–204.
26. Knudsen CW, Omland T, Clopton P, et al. Diagnostic value of B-type natriuretic peptide and chest radiographic findings in patients with acute dyspnea. *Am J Med* 2004;116:1–6.
27. Berman B, Spragg R, Maisel A. B-type natriuretic peptide (BNP) levels in differentiating congestive heart failure from acute respiratory distress syndrome (ARDS): abstracts from the 75th Annual Scientific Meeting of the American Heart Association. *Circulation* 2002;106:S3191.
28. Kucher N, Printzen G, Goldhaber S. Prognostic role of brain natriuretic peptide in acute pulmonary embolism. *Circulation* 2003;107:2545–2547.
29. Leuchte HH, Holzapfel M, Baumgartner RA, et al. Clinical significance of brain natriuretic peptide in primary pulmonary hypertension. *J Am Coll Cardiol* 2004;43(5):764–770.
30. Lubien E, DeMaria A, Krishnaswamy P, et al. Utility of B-natriuretic Peptide (BNP) in diagnosing diastolic dysfunction. *Circulation* 2002;105(5):595–601.
31. Krishnaswamy P, Lubien E, Clopton P, et al. Utility of B-natriuretic peptide (BNP) in elucidating left ventricular dysfunction (systolic and diastolic) in patients with and without symptoms of congestive heart failure at a veterans hospital. *Am J Med* 2001;111:274–279.
32. Maisel AS, McCord JM, Nowak RM, et al. Bedside B-type natriuretic peptide in the emergency diagnosis of heart failure: with reduced or preserved ejection fraction: results from the Breathing Not Properly (BNP) multinational study. *J Am Coll Cardiol* 2003;41(11):2010–2017.
33. Kenchaiah S, Evens JC, Levy D, et al. Obesity and the risk of heart failure. *N Engl J Med* 2002;347:358, 359.
34. Eckel RH, Barouch WW, Ershow AG. Report of the National Heart, Lung, and Blood Institute-National Institute of Diabetes and Digestive and Kidney Diseases Working Group on the Pathophysiology of Obesity-Associated Cardiovascular Disease. *Circulation* 2002;105:2923–2928.
35. Banerjee P, Banerjee T, Khand A, et al. Diastolic heart failure: neglected or misdiagnosed? *J Am Coll Cardiol* 2002;39:138–141.
36. Mehra MR, Uber PA, Park M, et al. Obesity and suppressed B-type natriuretic peptide levels in heart failure. *J Am Coll Cardiol* 2004;43(9):1590–1595.
37. McCord J, Mudny BJ, Hudson MP, et al. The relationship between obesity and B-type natriuretic peptide levels. *Arch Intern Med* 2004;164:2247–2252.
38. Koglin J, Pehlivanli S, Schwaiblmair M, et al. Role of brain natriuretic peptide in risk stratification of patients with congestive heart failure. *J Am Coll Cardiol* 2001;38:1934–1941.
39. Harrison A, Morrison LK, Krishnaswamy P, et al. B-type natriuretic peptide (BNP) predicts future cardiac events in patients presenting to the emergency department with dyspnea. *Ann Emerg Med* 2002;39: 131–138.
40. Cheng VL, Krishnaswamy P, Kazanegra R, et al. A rapid bedside test for B-type natriuretic peptide predicts treatment outcomes in patients admitted with decompensated heart failure. *J Am Coll Cardiol* 2001; 37:386–391.
41. Bettencourt P, Ferreira S, Azevedo A, et al. Preliminary data on the potential usefulness of B-type natriuretic peptide levels in predicting outcomes after hospital discharge in patients with heart failure. *Am J Med* 2002;113(3):215–219.
42. Berger R, Huelsman M, Strecker K, et al. B-type natriuretic peptide predicts sudden death in patients with chronic heart failure. *Circulation* 2002;105:2392–2397.
43. Bradley DJ, Bradley EA, Baughman KL, et al. Cardiac resynchronization and death from progressive heart failure: a meta-analysis of randomized controlled trials. *JAMA* 2003;289:730.
44. Sinha A-M, Filzmaier K, Breithardt O-A, et al. Usefulness of brain natriuretic peptide release as a surrogate marker of the efficacy of long-term cardiac resynchronization therapy in patients with heart failure. *Am J Cardiol* 2003;91:755–758.
45. Olivetti G, Abbi R, Quaini F, et al. Apoptosis in the failing human heart. *N Engl J Med* 1997;336:1131–1141.

46. Sato Y, Yamada T, Taniguchi R, et al. Persistently increased serum concentrations of cardiac troponin T in patients with idiopathic dilated cardiomyopathy are predictive of adverse outcomes. *Circulation* 2001;103:369–374.
47. Horwich T, Patel J, MacLellan W, Fonarow G. Cardiac troponin I is associated with impaired hemodynamics, progressive left ventricular dysfunction, and increased mortality rates in advanced heart failure. *Circulation* 2003;108:833–838.
48. Freitag MH, Vasani RS. Screening for left ventricular systolic dysfunction: the use of BNP. *Heart Fail Monitor* 2003;4(2):1–7.
49. Vasani RS, Benjamin EJ, Larson MG, et al. Monitoring Cardiovascular Disease investigation. Plasma natriuretic peptides for community screening for left ventricular hypertrophy and systolic dysfunction: the Framingham heart study. *JAMA* 2002;288:194–202.
50. Silver MA, Pisano C. High incidence of elevation B-type natriuretic peptide levels and risk factors for heart failure in an unselected at-risk population (stage A): implications for heart failure screening programs. *Congest Heart Fail* 2003;9:194–200.
51. Cowie MR, Struthers AD, Wood DA, et al. Value of natriuretic peptides in assessment of patients with possible new heart failure in primary care. *Lancet* 1997;350:1349–1353.
52. Epshteyn V, Morrison K, Krishnaswamy P, et al. Utility of B-type natriuretic peptide (BNP) as a screen for left ventricular dysfunction in patients with diabetes. *Diabetes Care* 2003;26(7):2081–2087.
53. Atisha D, Bhalla MA, Morrison LK, et al. A prospective study in search of an optimal BNP level to screen patients for cardiac dysfunction. *Am Heart J* 2004;148:518–523.
54. Heidenreich PA, Gubens MA, Fonarow GC, et al. Cost-effectiveness of screening with B-type natriuretic peptide to identify patients with reduced left ventricular ejection fraction. *J Am Coll Cardiol* 2004;43:1019–1026.
55. Maisel A. Updated algorithms for using B-type natriuretic peptide (BNP) levels in the diagnosis and management of congestive heart failure. *Crit Pathways Cardiol*, in press.
56. Krumholz HM, Parent EM, Tu N, et al. Readmission after hospitalization for congestive heart failure among Medicare beneficiaries. *Arch Intern Med* 1997;157:99–104.
57. Konstam MA, Kimmelstiel CD. Economics of heart failure. In: Balady GJ, Pina IL, eds. *Exercise and Heart Failure*. Futura, Armonk, NY, 1997, pp. 19–281.
58. Kazanegra R, Cheng V, Garcia A, et al. A rapid test for B-type natriuretic peptide correlates with falling wedge pressures in patients treated for decompensated heart failure: a pilot study. *J Cardiac Fail* 2001;7:21–29.
59. Stevenson LW. Tailored therapy to hemodynamic goals for advanced heart failure. *Eur J Heart Fail* 1999;1:252–257.
60. Maisel A. Algorithm for using b-type natriuretic peptide levels in the diagnosis and management of congestive heart failure. *Crit Pathways Cardiol* 2000;1(2):68–73.
61. Sodian R, Loebe M, Schmitt C, et al. Decreased plasma concentrations of brain natriuretic peptide as a potential indicator of cardiac recovery in patients supported by mechanical circulatory assist systems. *J Am Coll Cardiol* 2001;38:1942–1949.
62. Richardson AM, Doughty R, Nicholls MG, et al. Neurohumoral predictors of benefit from Carvedilol in ischemic left ventricular dysfunction. *Circulation* 1999;99:786–797.
63. Troughton RW, Frampton CM, Yandle TG, et al. Treatment of heart failure guided by plasma amino terminal brain natriuretic peptide (N-BNP) concentrations. *Lancet* 2000;355:1126–1130.
64. Anand IS, Fisher LD, Chiang Y-T, et al., for the Val-HeFT Investigators. Changes in brain natriuretic peptide and norepinephrine over time and mortality and morbidity in the Valsartan Heart Failure Trial (Val-HeFT). *Circulation* 2003;107:1278–1283.
65. Silver MA, Maisel A, Yancy CW, et al. BNP Consensus Panel 2004: A clinical approach for the diagnostic, prognostic, screening, treatment monitoring, and therapeutic roles of natriuretic peptides in cardiovascular diseases. *Congest Heart Fail* 2004;10(5 Suppl 3):1–30.
66. Wieczorek SJ, Wu AH, Christenson R, et al. A rapid B-type natriuretic peptide assay accurately diagnoses left ventricular dysfunction and heart failure: a multicenter evaluation. *Am Heart J* 2002;144:834–839.
67. Anand IS, Fisher LD, Chiang YT, et al. Changes in brain natriuretic peptide and norepinephrine over time and mortality and morbidity in the Valsartan Heart Failure Trial (Val-HeFT). *Circulation* 2003;107:1278–1283.

# 24

---

## Natriuretic Peptides in Acute and Chronic Coronary Artery Disease

---

*Shuaib M. Abdullah, MD*  
*and James A. de Lemos, MD*

### CONTENTS

INTRODUCTION  
PATTERNS OF BNP SYNTHESIS AND RELEASE IN CARDIAC ISCHEMIA  
POSSIBLE MECHANISMS OF BNP SYNTHESIS AND RELEASE  
IN ISCHEMIC HEART DISEASE  
BNP AS A DIAGNOSTIC TOOL IN ISCHEMIC HEART DISEASE  
NATRIURETIC PEPTIDES AS PROGNOSTIC TOOLS IN ISCHEMIC  
HEART DISEASE  
USING BNP AND NT-PROBNP TO SELECT PATIENTS  
FOR AN EARLY INTERVENTIONAL STRATEGY  
PROPOSED APPLICATION OF BNP IN ACS  
INCORPORATING NATRIURETIC PEPTIDES WITH OTHER CLINICAL  
AND BIOCHEMICAL MARKERS OF RISK  
CONCLUSION  
REFERENCES

---

### SUMMARY

In addition to their diagnostic and prognostic utility in patients with congestive heart failure, recent data have demonstrated that B-type natriuretic peptide (BNP) and N-terminal-pro (NT-pro)BNP are associated with adverse cardiovascular events in patients presenting with acute coronary syndrome (ACS). Several mechanisms may lead to the elevations seen in plasma levels of these markers in patients with coronary artery disease, including increased left-ventricular wall tension, ischemia, and natriuretic peptide synthesis within atherosclerotic plaques. Despite the robust and consistent association seen in multiple cohorts of ACS patients between elevated levels, and BNP and NT-proBNP and mortality and incident heart failure, data defining the optimal treatment strategy for these high-risk patients are limited. Future work is needed to identify the role of BNP and NT-proBNP in the development of ACS risk scores with traditional clinical factors and other biomarkers, and to evaluate the efficacy of different therapeutic measures in improving the prognosis of patients with elevated levels of these peptides.

**Key Words:** Acute coronary syndrome; risk stratification; coronary artery disease; brain natriuretic peptide.

From: *Contemporary Cardiology:  
Cardiovascular Biomarkers: Pathophysiology and Disease Management*  
Edited by: David A. Morrow © Humana Press Inc., Totowa, NJ

Table 1  
Characteristics of an Ideal Biomarker

- 
- Has been tested in prospective studies to validate its prognostic and diagnostic efficacy
  - Provides additional information to already established clinical parameters
  - Is cost-effective
  - Is easy to handle and measure
  - Provides information that could lead to a change in therapeutic strategies
- 

## INTRODUCTION

A rapid accumulation of evidence has indicated that B-type natriuretic peptide (BNP) and the N-terminal fragment of its prohormone (NT-proBNP) are robust markers of the risk for mortality and new congestive heart failure (CHF) in patients presenting with acute coronary syndrome (ACS). Although the clinical applications of BNP and NT-proBNP are still in the developmental stage in this setting, these markers fulfill the majority of criteria for an “ideal” biomarker (Table 1) when applied to patients with ACS. This chapter reviews the measurement of BNP and NT-proBNP in patients with ischemic heart disease, focusing on mechanisms of release in coronary ischemia and the use of these biomarkers for risk stratification in patients with ACS.

### *Risk Assessment in ACSs*

Multiple factors have been shown to predict worse outcomes in patients with ACS (Table 2) (1–3). Among the strongest correlates of mortality following ACS are Killip class on admission, heart failure, impairment in left ventricular systolic function (LVSF), and larger left ventricular dimensions (2,4,5).

Several risk models, such as the Thrombolysis in Myocardial Infarction (TIMI) risk score for unstable angina/non-ST-elevation myocardial infarction (NSTEMI), have been proposed that combine multiple individual variables to improve prognostic performance (6). However, some of these models do not take into account a measure of LVSF, which has been shown to provide additional prognostic information (7). Measurement of LVSF by transthoracic echocardiography may not be practical at the time of presentation with ACS, resulting in delays in the identification of high-risk patients. Moreover, echocardiography and the physical examination may underestimate the severity of hemodynamic consequences of ischemia in patients without systolic dysfunction. Because plasma BNP and NT-proBNP levels provide insight with respect to the presence of hemodynamic stress and correlate with LVSF, their addition to these indices may improve prognostic performance. Rapid immunoassays for BNP and NT-proBNP have been developed that yield results within 30 min, allowing their real-time use in urgent-care facilities.

## PATTERNS OF BNP SYNTHESIS AND RELEASE IN CARDIAC ISCHEMIA

Natriuretic peptide levels are elevated both in animal models and in patients with coronary ischemia. In rats that underwent coronary artery ligation, BNP concentration in the left ventricle increased twofold at 12 h and fivefold at 24 h postinfarction, whereas atrial natriuretic peptide (ANP) levels were unchanged (8). Elevated levels of BNP were found in noninfarcted as well as in infarcted areas of the myocardium, suggesting that increased

Table 2  
Prognostic Factors in ACSs

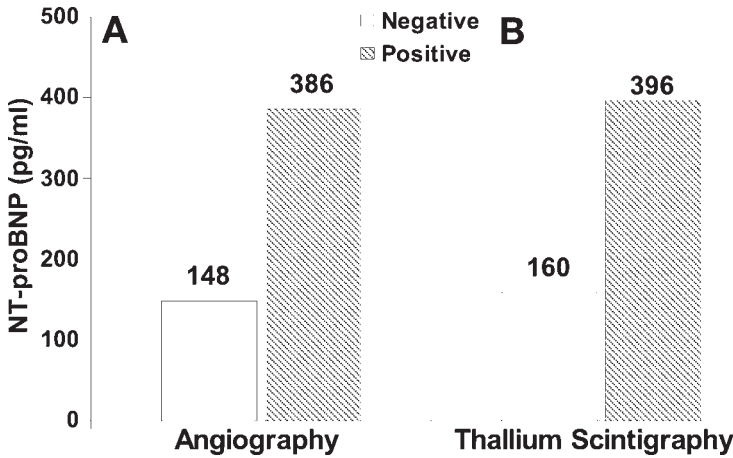
Demographic characteristics
Age
African-American race
Female gender
Comorbidities
CHF
Hypertension
Diabetes
Chronic kidney disease
Peripheral vascular disease
Physical examination
Killip class
Elevated heart rate
Low blood pressure
Biomarkers
Cardiac troponin I or T
C-reactive protein
BNP and NT-proBNP
Other
Angiographic or ECG evidence of more extensive disease
Reduced LVSF
Aggressive pace of symptoms

plasma levels of BNP are not simply a “spillover” from infarcted tissue but, rather, a reflection of increased active synthesis by viable myocardial cells. Increased expression of BNP mRNA in the left ventricle further supports this argument.

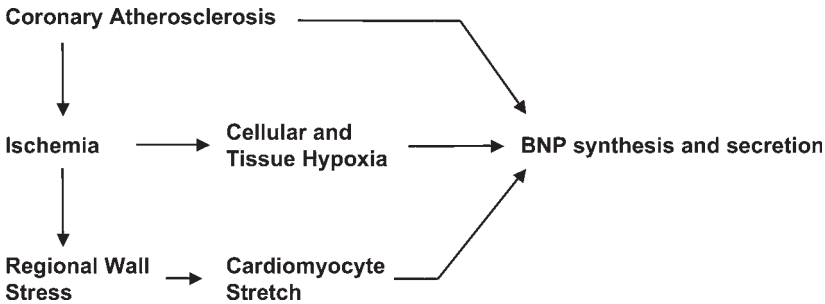
The plasma concentration of BNP rises in patients with acute myocardial infarction (AMI) more rapidly and to a much greater extent than does the concentration of ANP (9). Both BNP and NT-proBNP levels are higher in patients with anterior MI than in those with inferior MI (9,10). In addition, the time course of the rise in inferior STEMI may be characterized by a single peak during the first day, whereas in anterior STEMI, a biphasic pattern of BNP secretion is common, with the first peak occurring between 1 and 2 d and the second between 4 and 6 d after infarction.

The rise in BNP and NT-proBNP concentration may be sustained over several weeks after ACS and correlates with infarct size, as measured by cardiac enzyme release (11), by thallium-201 single-photon emission computed tomography (SPECT), or contrast-enhanced MRI (12,13). In patients with non-ST-elevation ACS (NSTEMI) with preserved LVSF, NT-proBNP levels also correlate with the extent of regional wall motion abnormalities as assessed by echocardiography (14).

When compared with healthy control subjects and those with stable angina, patients with unstable angina have higher BNP and NT-proBNP levels during the acute phase of illness, with return to near baseline levels following medical stabilization (10,15). In patients with stable coronary artery disease (CAD), BNP and NT-proBNP concentrations rise after exercise (or with dobutamine stress) in proportion to the size of the ischemic territory as measured by nuclear scintigraphy or echocardiography (16,17). In this setting, BNP rises to a greater extent than does NT-proBNP, probably owing to the rapid release of the fully processed active hormone from storage granules (16,17). BNP levels may also



**Fig. 1.** Resting NT-proBNP levels in patients without (white bars) and with (slashed bars) either CAD detected on angiography (A) or inducible changes seen on thallium scintigraphy (B). (Adapted from ref. 19.)



**Fig. 2.** Proposed mechanisms of BNP release in coronary ischemic disease.

be elevated at rest in patients with stable angina. The resting plasma concentration of BNP in patients with CAD correlates with inducible ischemia seen on exercise echocardiography and SPECT imaging. Similarly, resting plasma NT-proBNP levels are independently associated with inducible changes on thallium-201 SPECT and with the number of stenotic vessels detected by angiography (Fig. 1) (16–19).

### POSSIBLE MECHANISMS OF BNP SYNTHESIS AND RELEASE IN ISCHEMIC HEART DISEASE

Since ischemia may lead to left ventricular systolic and diastolic dysfunction and consequently to increased myocardial stretch, which is the primary stimulus for natriuretic peptide release, it is not surprising that plasma levels of BNP and NT-proBNP are elevated following ischemia. However, other possible mechanisms may also lead to increased BNP synthesis and release in this setting (Fig. 2).

#### *Hypoxia as a Stimulus for Natriuretic Peptide Release*

In vivo and in vitro animal experimental evidence suggests that hypoxia/ischemia itself may directly induce the synthesis and secretion of natriuretic peptides. Rats trained in hypobaric hypoxic conditions show increased expression of BNP mRNA (20). Moreover, an

increase in tissue BNP was observed minutes after left coronary ligation in isolated rat hearts, during which time no change in left ventricular end diastolic pressure (LVEDP) was measured (21). Rat hearts perfused by hypoxic buffer demonstrated increased secretion of ANP and BNP (22). Evidence of increased natriuretic peptide release is also seen in cultured human atrial myocytes incubated in hypoxic buffer (23). In addition, cell transfection of hypoxia-inducible factor-1, a transcription factor that upregulates many hypoxia-inducible genes, increases BNP expression (24).

Observational studies in humans also support the theory that myocyte hypoxia *per se* may be a stimulus for BNP and NT-proBNP secretion. Patients with angiographically confirmed CAD and normal LVEF have higher BNP and NT-proBNP plasma levels than patients without CAD (25). Elevated ventricular BNP expression, as assessed by real-time polymerase chain reaction, is seen in biopsies of ischemic myocardium taken during coronary artery bypass graft (CABG) and correlates with plasma levels. In another study, biopsies taken during CABG demonstrate greater expression of ANP and BNP in ischemic myocardium compared with nonischemic myocardium (26). In addition, euvolemic patients with cyanotic congenital heart disease have elevated NT-proBNP and NT-proANP levels compared with patients who have repaired congenital heart defects or structurally normal heart (23).

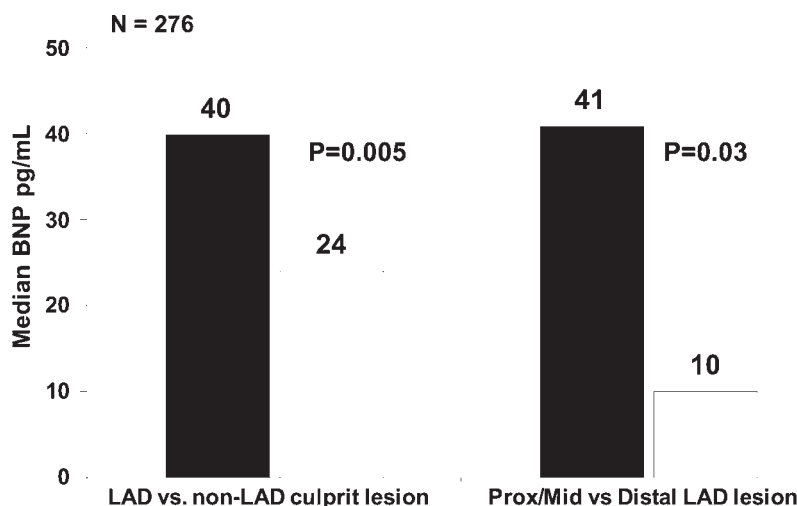
Angiographic evidence further strengthens a direct relationship between ischemia and BNP and NT-proBNP. In multivariable models of the determinants of plasma BNP concentration in patients with NSTEMI, angiographic severity as demonstrated by Gensini score is associated with natriuretic peptide levels independent of LVEF, wall motion abnormalities, wall stress index, and left ventricular mass index (14). BNP levels increase transiently with brief periods of ischemia induced by percutaneous transluminal coronary angioplasty (PTCA) in patients with stable angina (27). Changes in BNP are not seen in patients who undergo only diagnostic catheterization, and no significant difference is evident in hemodynamic parameters 24 h after PTCA, suggesting that tissue ischemia itself may be the primary stimulus (28). In patients who underwent repeat angiography a median of 5 mo after undergoing primary angioplasty during STEMI, patency of the culprit lesion was associated with a decrease in BNP levels from the time of infarct, whereas restenosis of the lesion was associated with persistent elevations (29). Furthermore, patients with ACS presenting with elevated BNP levels have more severe culprit artery stenoses and are more likely to have a lesion in the proximal left anterior descending (LAD) artery than in other vascular territories (Fig. 3) (30).

### ***Ventricular Dysfunction as a Stimulus for BNP Release***

Increased BNP synthesis and secretion may be owing to increased wall stress from ischemia-induced ventricular dysfunction. BNP levels positively correlate with hemodynamic parameters that reflect ventricular dysfunction, including LVEDP, and negatively correlate with left ventricular ejection fraction (LVEF) (31).

A retrospective study reported that 30% of patients who develop heart failure after MI have preserved LVFS and are thought to have “diastolic dysfunction” (32). Since neurohormonal activation occurs in this group of patients, it has also been proposed that a minor degree of left ventricular systolic dysfunction may be present but may not be detectable because BNP decreases afterload and maintains ejection fraction (33). Compared with patients without significant CAD, patients with coronary artery stenoses have elevated BNP levels and LVEDP independent of LVFS (34).





**Fig. 3.** Median concentration of BNP in patients with lesions in LAD artery (black bars) vs lesions in other vessels (white bars) and in patients with lesions in proximal/mid-LAD (black bars) vs distal LAD artery (white bars). (Adapted from ref. 30.)

**Table 3**  
Potential Beneficial Actions of BNP in CAD

<i>Vascular</i>	<i>Renal</i>	<i>Cardiac</i>
Vasodilator		
Decreased sympathetic tone	Natriuresis/diuresis	Improved diastolic function
Decreased smooth muscle proliferation	Increased glomerular filtration rate	Improved hemodynamics
Increased vascular permeability		Decreased infarct size
Increased arterial distensibility		Preconditioning
		Decreased cardiac fibrosis

### ***Coronary Atherosclerosis as a Stimulus for BNP Release***

Natriuretic peptide expression within human coronary arteries has also been reported, with upregulated gene expression in atherosclerotic regions compared with normal arterial segments (35). This finding raises the possibility that BNP may have an autocrine/paracrine role in coronary atherosclerosis, as outlined in Table 3.

### **BNP AS A DIAGNOSTIC TOOL IN ISCHEMIC HEART DISEASE**

Although increased plasma BNP concentration may be seen with coronary ischemia, this marker is not well suited for the diagnosis of ACS or ischemia, because it is neither sensitive nor specific for this purpose. First, BNP levels are affected by many other conditions (Table 4). Second, and more important, the magnitude of BNP elevation in patients with ischemia or ACS is typically less than in patients with left ventricular systolic dysfunction. In many patients with definite ACS, BNP levels fall well within the normal range.

### **NATRIURETIC PEPTIDES AS PROGNOSTIC TOOLS IN ISCHEMIC HEART DISEASE**

The prognostic utility of both ANPs and BNP has been assessed in the setting of ACS. Whereas elevated plasma ANP levels are related to increased mortality risk after MI, they

Table 4  
Nonischemic Factors Affecting BNP Levels

<i>BNP release</i>	<i>BNP clearance</i>
Left ventricular systolic dysfunction	"Age
Left ventricular diastolic dysfunction	Chronic kidney disease
Pulmonary embolism	Obesity
Sepsis	Female gender
Right heart failure	
Hypertension	
Valvular heart disease (e.g., aortic stenosis)	

do not appear to contribute additional prognostic information when added to other known predictors of increased mortality, such as LVEF (36). Levels of plasma NT-proANP correlate more strongly than ANP with future risk of mortality and, in contrast to ANP, the association between NT-proANP and mortality remains significant after adjusting for Killip class, LVEF, and infarct location (37). However, available data suggest that the BNP provides superior prognostic information to ANP and NT-proANP (38), and given the wide availability of assays for BNP and NT-proBNP, there has been little interest in the development of commercial assays for ANP or NT-proANP.

### ***BNP and NT-proBNP and Risk of Heart Failure and Death After STEMI***

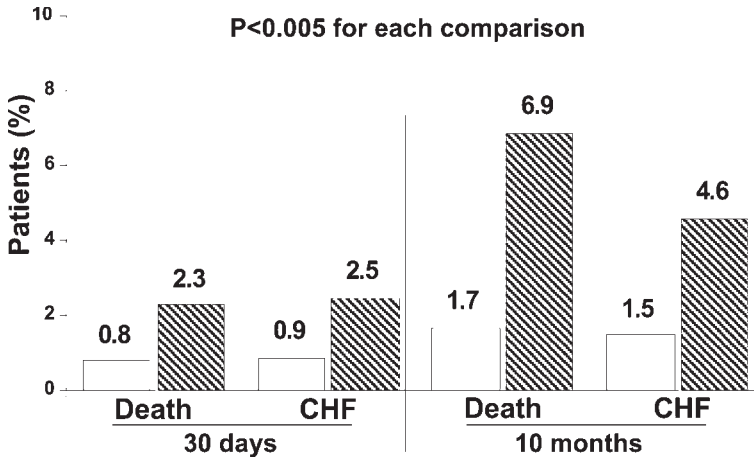
The use of BNP to diagnose heart failure can be expanded to patients presenting with ACS. In patients presenting with AMI, BNP was equivalent to echocardiography, and superior to clinical evaluation in the detection of LVEF < 40% (39). In addition, BNP levels drawn on admission help to identify patients who are likely to develop chronic LVSD (11), with adverse left ventricular remodeling and dilatation (40,41).

Given the association between BNP and heart failure, it is not surprising that higher BNP levels identify patients at increased risk of mortality after STEMI. In a pilot study, Darbar et al. (42) found that BNP measured 3 d after STEMI was associated with cardiovascular mortality over a follow-up period of almost 2 yr. A second study showed that following STEMI in 70 patients, mortality was higher in those with BNP levels above the median (>43 pg/mL) measured at 6 h and 2 d after the onset of chest pain (43). NT-proBNP has also been shown to be associated with mortality and new onset of CHF after STEMI independently of LVEF (44).

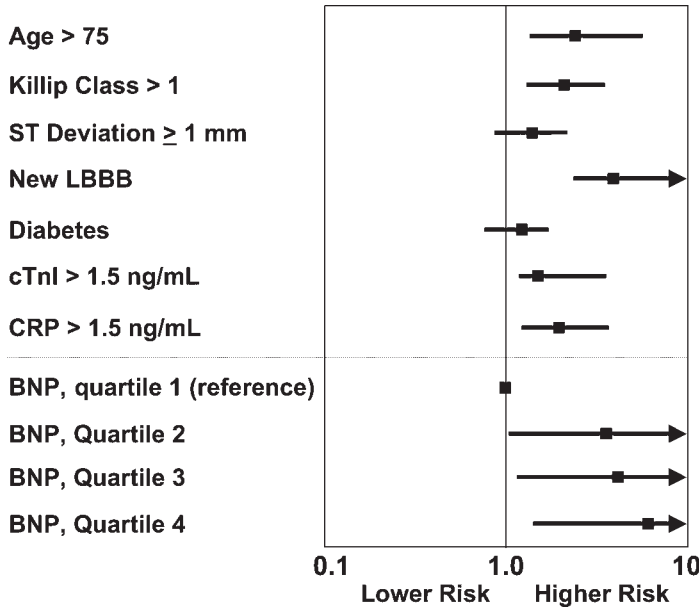
### ***Prognostic Role of BNP and NT-proBNP Across Spectrum of ACS***

#### **STUDIES OF BNP**

A substudy of the Orbofiban in Patients with Unstable Coronary Syndromes-Thrombolysis in Myocardial Infarction 16 (OPUS-TIMI 16) trial was among the first to evaluate the prognostic capabilities of BNP in a large population of patients across the entire spectrum of ACS (45). In this study, BNP was measured in 2525 patients at a mean of 40 h after presenting with STEMI, NSTEMI, or unstable angina. BNP levels on admission correlated with age, male gender, white race, hypertension, CHF, peripheral vascular disease, hypercholesterolemia, and smoking status. In addition, elevated levels of BNP were associated with Killip class >1, electrocardiogram (ECG) changes, elevated creatine kinase-MB, and chronic kidney disease. A plasma concentration of BNP > 80 pg/mL was a powerful



**Fig. 4.** Incidence of death and new CHF at 30 d and 10 mo following ACS in patients with a BNP  $\leq 80$  pg/mL (white bars) and  $>80$  pg/mL (slashed bars). (Adapted from ref. 45.)



**Fig. 5.** Adjusted risk of 10-mo mortality. A stepwise logistic-regression model showing the association between selected baseline clinical variables and the odds of death at 10 mo in the OPUS-TIMI 16 study is shown. (Adapted from ref. 45.) LBBB, left bundle branch block; CRP, C-reactive protein.

predictor of mortality and CHF at 30 d and 10 mo even after adjustment for traditional prognostic variables including troponin I (cardiac troponin I [cTnI]), CHF, gender, chronic kidney disease, and ST-segment deviation (Fig. 4). When patients were divided into quartiles based on BNP results at the time of entry into the study, the multivariable-adjusted odds ratios (ORs) for mortality at 10 mo were 3.8, 4.0, and 5.8 for the second, third, and fourth quartiles, respectively, compared with the first quartile (Fig. 5).

These findings have been confirmed and extended in a series of additional studies (Table 5). In 1676 patients with NSTEMI or unstable angina enrolled in the Treat Angina with Aggrastat and Determine Cost of Therapy with Invasive or Conservative Strategy

Table 5  
Summary of BNP/NT-proBNP Studies in ACS

<i>Reference</i>	<i>n</i>	<i>Type of ACS</i>	<i>BNP and NT-proBNP</i>	<i>Time of sampling</i>	<i>Follow-up</i>	<i>Key findings/results</i>
45	2525	All	BNP	<3 d	10 mo	BNP associated with survival across the entire spectrum of ACS
47	609	All	NT-proBNP	3 d	4 yr	Demonstration that NT-proBNP adds value to LVEF
50	755	NSTEACS	NT-proBNP	On admission	40 mo	Prognostic value independent of troponins provided by very early measurements
55	2019	NSTEACS	NT-proBNP	39 h	2 yr	Benefit from invasive therapy in patients with concomitant NT-proBNP and interleukin-6
46	1676	NSTEACS	BNP		6 mo	Validation of 80-pg/mL threshold for BNP and demonstration of incremental value of troponin
49	666	STEMI and NSTEMI	BNP and NT-proBNP	1–4 d	3 yr	NT-proBNP and BNP predict mortality independent of LVEF with no major difference between NT-proBNP and BNP
48	6809	NSTEMI	NT-proBNP	9.5 h	1 yr	Largest study to date showing stepwise association between NT-proBNP and mortality
52	438	STEMI	BNP	6 h	30 d	Measurement at presentation and association with markers of failed reperfusion and worse outcome in STEMI
51	1756	NSTEMI and STEMI	NT-proBNP	3 h	30 d	NT-proBNP associated with mortality independent of troponin T or ECG changes
53	145	NSTEMI and STEMI	BNP	3–4 wk	58.6 mo	Prognostic power of BNP drawn 3–4 wk after infarct retained
54	1791	NSTEACS	NT-proBNP	Baseline, 48 h, and 72 h	30 d	Possible improvement in risk stratification with serial measurement compared with a single measurement

Table 6  
Comparison of BNP and NT-proBNP to LVEF for Prediction of Mortality after ACS<sup>a</sup>

	<i>Sensitivity (%)</i>	<i>Specificity (%)</i>	<i>PPV</i>	<i>NPV</i>	<i>AUC</i>
NT-proBNP (162 pmol/L)	80	72	25	97	0.81
BNP (30 pmol/L)	71	76	25	96	0.81
LVEF (40%)	78	64	25	95	0.76

<sup>a</sup>Adapted from ref. 49. PPV, positive predictive value; NPV, negative predictive value; AUC, area under the curve.

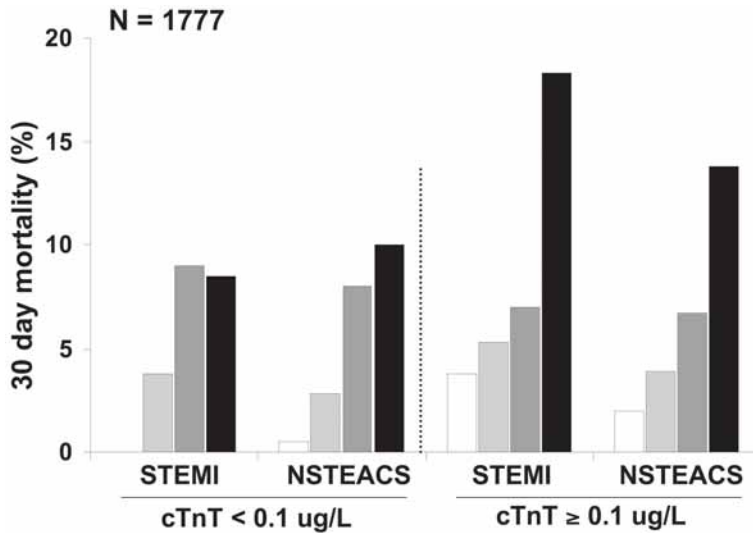
(TACTICS)-TIMI-18 trial, a BNP level >80 pg/mL was associated with higher mortality and heart failure at 6 mo independent of age, gender, diabetes, troponin levels, ST-segment depression, and clinical evidence of heart failure. In this study, 80 pg/mL (Biosite assay) appeared to be the optimal cut point for prediction of mortality (46).

### STUDIES OF NT-PROBNP

Plasma levels of NT-proBNP have also been evaluated as a prognostic marker after ACS (47–49). In a study in which routine echocardiographic measurements of LVEF were performed, NT-proBNP levels, measured 3 d after STEMI, NSTEMI, and unstable angina, were higher in patients who died after a median of 51 mo compared with those who survived (47). The relative risk (RR) after adjustment for other risk factors (including LVEF) was 2.1 for the group with NT-proBNP above the median compared with those with NT-proBNP below the median. In a substudy of the Global Utilization of Strategies to Open occluded arteries-IV trial, the largest study to date of natriuretic peptides in ACS ( $n = 6809$ ), the baseline concentration of NT-proBNP was the strongest predictor of mortality after NSTEMI, outperforming cTnT, creatinine clearance, and ST-segment depression (48). Notably, consistent with other studies, NT-proBNP did not predict recurrent MI in an independent manner. Finally, in a study of 666 patients with STEMI and NSTEMI, BNP, NT-proBNP, and LVEF were found to be independent predictors of mortality, heart failure, and recurrent MI independent of age, gender, previous MI, history of diabetes or hypertension, previous heart failure, creatinine, and coronary revascularization procedures (49). Elevated levels of BNP and NT-proBNP were associated with increased mortality even in patients with normal LVSF. In that study, which directly compared BNP and NT-proBNP, there was no significant advantage of one peptide over the other (Table 6).

### Timing of Measurement

The baseline measurements of BNP and NT-proBNP in the aforementioned studies were performed between 9.5 h and 4 d after enrollment. Recent data suggest that even earlier measurements may be of value. A substudy of the Fast Assessment in Thoracic Pain study evaluated NT-proBNP in patients with NSTEMI and unstable angina (50). NT-proBNP levels were drawn on admission in 755 patients, who were subsequently followed for 40 mo. NT-proBNP levels correlated with future risk of mortality independent of ECG changes and cTnT. In another study, NT-proBNP levels drawn a median of 3 h after the onset of symptoms in patients presenting with STEMI, NSTEMI, or unstable angina were associated with CHF and mortality across the spectrum of ACS independent of other factors, including cTnT (Fig. 6) (51). Compared with the first quartile of NT-proBNP concentration, the second, third, and fourth quartiles had an RR of mortality of 2.9, 5.3, and 11.5, respectively. Mega et al. (52) studied the prognostic value of BNP drawn within 6 h of onset



**Fig. 6.** Association between mortality and NT-proBNP. The first (white bars), second (light gray bars), third (dark gray bars), and fourth (black bars) quartiles according to cTnT levels in patients with STEMI and NSTEMI/ACS are shown. (Adapted from ref. 51.)

in patients who presented with STEMI. Patients with a BNP >80 pg/mL had a sevenfold higher risk of mortality than those with a BNP <80 pg/mL independent of other known clinical prognostic parameters, including cTnI and CRP; a significant difference was noted as early as 48 h after enrollment. Patients with elevated BNP were also more likely to have incomplete reperfusion and incomplete resolution of ST-elevation after thrombolytic therapy. At the other extreme, it appears that BNP measured as late as 3 to 4 wk after MI retains its prognostic capacity (53).

Heeschen et al. (54) found that serial measurements of NT-proBNP at baseline, 48 h, and 72 h after ACS provided additional risk stratification information compared with baseline measurement alone. In this substudy of the PRISM trial, clinical stabilization was associated with a 25% reduction in NT-proBNP levels by 48 h and a 50% reduction by 72 h. Patients with persistent elevation in NT-proBNP levels >250 mg/dL at 72 h were at markedly increased risk of death or MI (OR: 33.7; 95% confidence interval [CI]: 8.2–138.8;  $p < 0.001$ ), as were those who developed new elevation in NT-proBNP >250 mg/dL after hospitalization (OR: 24.0; 95% CI: 8.4–68.5;  $p < 0.001$ ).

### **Summary of Application for Risk Stratification**

BNP and NT-BNP are robust predictors of increased mortality and future incidence of CHF independent of traditional risk factors in patients who present with ACS. The consistency of these findings across multiple studies is notable (Table 5). The evidence suggesting that these peptides are predictors of nonfatal recurrent ischemic events is less clear. When adjusted for other risk factors for nonfatal MI, BNP and NT-proBNP do not appear to be independently associated with this outcome. However, caution is necessary when interpreting these data, because it is possible that recurrent MI is more likely to be fatal in patients with a persistent elevation in BNP. BNP or NT-proBNP levels drawn as early as a few hours to as late as several weeks after presentation are associated with a risk of early and long-term mortality. Further study is needed to determine the optimal timing and/or the need for serial assessment of BNP and NT-proBNP in ACS.

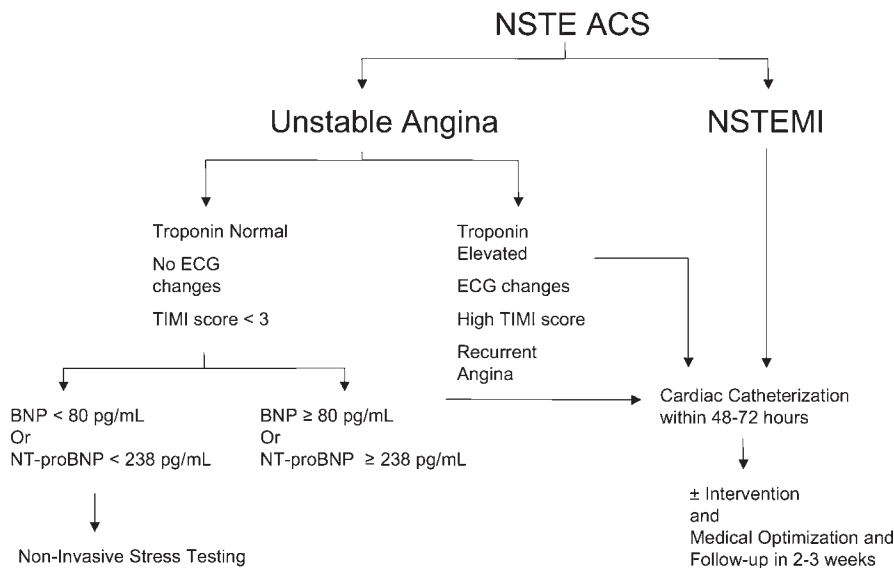
## USING BNP AND NT-proBNP TO SELECT PATIENTS FOR AN EARLY INTERVENTIONAL STRATEGY

Despite the consistent evidence supporting the use of BNP and NT-proBNP to identify patients at risk of death and heart failure following ACS, few data are available to guide clinicians with respect to the therapeutic implications of these findings. An aggressive approach to coronary revascularization following ACS may be of benefit for patients with BNP or NT-proBNP elevation. However, two retrospective studies evaluating the use of BNP and NT-proBNP to select patients for an invasive management strategy have shown seemingly conflicting results. In a substudy of TACTICS-TIMI 18, although BNP levels were strongly associated with the risk of death after NSTEMI, BNP did not identify a subgroup who derived particular benefit from the early invasive management strategy (46). By contrast, in a FRISC II substudy, patients who presented with NSTEMI and elevated plasma levels of both NT-proBNP and IL-6 had a survival benefit when they were assigned to an early invasive instead of an early conservative strategy (55). Because the benefit of invasive therapy in the FRISC II substudy was restricted to the highly selected subgroup with elevation in both NT-proBNP and IL-6, the findings should be interpreted with some caution until they are confirmed in additional studies (46).

The discrepancy in the results of these two substudies is not likely owing to a difference between NT-proBNP and BNP but, rather, owing to differences in the design of the two clinical trials (56,57). In TACTICS-TIMI 18, the requirements for patients in the conservative group to “cross over” and undergo angiography and intervention were much more liberal than in the FRISC II study. As a result, revascularization was performed in 36% of patients randomized to the conservative arm during the initial hospitalization in TACTICS-TIMI 18, compared with only 9% within the first 10 d in the conservative arm of FRISC II. The more liberal crossover in the conservative arm of TACTICS-TIMI 18 may have minimized the difference in mortality seen between the conservative and invasive groups: in TACTICS-TIMI 18 no difference in mortality was evident between groups, whereas in FRISC II, a 43% reduction in mortality at 1 yr was seen in the invasive arm. Because BNP and NT-proBNP are markers of mortality rather than nonfatal ischemic events, it is logical that they would perform best in studies in which the active therapy influenced mortality.

### PROPOSED APPLICATION OF BNP IN ACS

At the present time, adequate data do not exist to define the proper role of BNP and NT-proBNP in stratifying patients to more aggressive interventional therapy, and the clinician must consider plasma levels of these peptides in the context of other biomarkers and clinical factors before assigning a patient to a proper level of care. More research is needed to identify appropriate pharmacological and interventional strategies for high-risk patients with ACS and elevated levels of BNP or NT-proBNP. In the meantime, we propose the algorithm in Fig. 7 for patients with ACS. Patients who present with ACS and have elevated cardiac troponin or who are in a high TIMI risk category have been shown to benefit from an early interventional approach. In patients with a low TIMI risk score who have a normal troponin result, aggressive intervention may be considered for those patients who have BNP levels  $>80$  pg/mL (cut point based on studies using the Biosite and Bayer assays). Otherwise, a conservative approach may be pursued, with noninvasive testing. Regardless of which of these approaches is taken, medical therapy with aspirin, angiotensin-converting enzyme inhibitors, aldosterone antagonists,  $\beta$ -blockers, and statins should



**Fig. 7.** Algorithm for risk stratification for early invasive therapy in NSTEMI/ACS.

be maximized. High-risk patients with elevated BNP or NT-proBNP should be followed more closely than patients who do not have elevated levels of these biomarkers, with particular attention to the development of early signs of heart failure.

### INCORPORATING NATRIURETIC PEPTIDES WITH OTHER CLINICAL AND BIOCHEMICAL MARKERS OF RISK

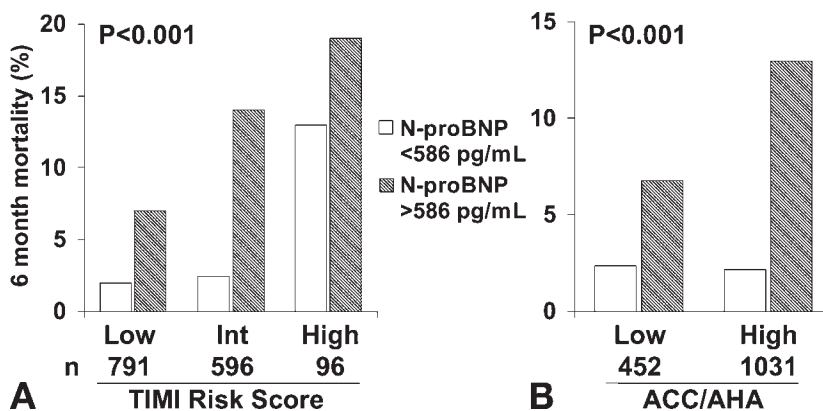
In all of the studies performed to date, BNP and NT-proBNP have been associated with mortality independent of troponin, supporting the hypothesis that natriuretic peptide levels identify a component of pathophysiology and risk in ACS that is not captured by necrosis markers. The concept that pathobiologically distinct biomarkers can be used together to enhance risk stratification has only begun to be explored. A combined substudy of the OPUS-TIMI 16 and TACTICS-TIMI 18 trials examined the interaction among BNP, CRP, and cTnI and showed the combined use of these markers to enhance risk stratification (58).

BNP and NT-proBNP also appear to improve the ability of existing clinical models to predict CHF and mortality. The addition of BNP >80 pg/mL to a risk score for CHF improved the performance of the model to predict new CHF in patients with ACS (59). Bazzino et al. (60) evaluated whether adding plasma NT-proBNP to the TIMI risk score for unstable angina and NSTEMI and to the 2002 American College of Cardiology (ACC)/American Heart Association (AHA) risk classification improved their predictive capacity for death. For each TIMI and ACC/AHA risk category, patients with an NT-proBNP >586 pg/mL had a significantly higher probability of death (Fig. 8).

### CONCLUSION

The natriuretic peptides BNP and NT-proBNP have the potential to play a significant clinical role in the management of a variety of cardiac diseases. Although the majority of data supporting their clinical use have been in CHF, subsequent work has shown that both BNP and NT-proBNP have prognostic value in patients presenting with ACS. Both peptides predict mortality and CHF across the entire spectrum of ACS. There are mixed data





**Fig. 8.** Six-month mortality according to NT-proBNP levels: (A) TIMI risk categories (0–2, low risk; 3–4, intermediate risk; 5–7, high risk) and (B) ACC/AHA classification (non-high risk and high risk). (Adapted from ref. 60.)

regarding their ability to predict nonfatal recurrent ischemic events. Thus, BNP and NT-proBNP should be considered as markers predominantly of death and heart failure rather than nonfatal recurrent ischemic events. Several additional areas need to be addressed regarding the future role of BNPs in clinical practice. Although some data support routine early invasive management for patients with elevated levels of BNP/NT-proBNP, the optimal therapeutic responses to abnormal BNP results are not yet defined. Other treatment options may be explored, optimally in randomized clinical trials, to identify therapies that may be effective in decreasing the high mortality and morbidity in patients with high plasma levels of these natriuretic peptides.

## REFERENCES

- Boersma E, Pieper KS, Steyerberg EW, et al. Predictors of outcome in patients with acute coronary syndromes without persistent ST-segment elevation: results from an international trial of 9461 patients. The PURSUIT Investigators. *Circulation* 2000;101:2557–2567.
- Califf RM, Pieper KS, Lee KL, et al. Prediction of 1-year survival after thrombolysis for acute myocardial infarction in the global utilization of streptokinase and TPA for occluded coronary arteries trial. *Circulation* 2000;101:2231–2238.
- Peterson ED, Shaw LJ, Califf RM. Risk stratification after myocardial infarction. *Ann Intern Med* 1997; 126:561–582.
- Steg PG, Dabbous OH, Feldman LJ, et al. Determinants and prognostic impact of heart failure complicating acute coronary syndromes: observations from the Global Registry of Acute Coronary Events (GRACE). *Circulation* 2004;109:494–499.
- Nicolosi GL, Latini R, Marino P, et al. The prognostic value of predischarge quantitative two-dimensional echocardiographic measurements and the effects of early lisinopril treatment on left ventricular structure and function after acute myocardial infarction in the GISSI-3 Trial. Gruppo Italiano per lo Studio della Sopravvivenza nell'Infarto Miocardico. *Eur Heart J* 1996;17:1646–1656.
- Antman EM, Cohen M, Bernink PJ, et al. The TIMI risk score for unstable angina/non-ST elevation MI: a method for prognostication and therapeutic decision making. *JAMA* 2000;284:835–842.
- Singh M, Reeder GS, Jacobsen SJ, Weston S, Killian J, Roger VL. Scores for post-myocardial infarction risk stratification in the community. *Circulation* 2002;106:2309–2314.
- Hama N, Itoh H, Shirakami G, et al. Rapid ventricular induction of brain natriuretic peptide gene expression in experimental acute myocardial infarction. *Circulation* 1995;92:1558–1564.
- Morita E, Yasue H, Yoshimura M, et al. Increased plasma levels of brain natriuretic peptide in patients with acute myocardial infarction. *Circulation* 1993;88:82–91.

10. Talwar S, Squire IB, Downie PF, et al. Profile of plasma N-terminal proBNP following acute myocardial infarction; correlation with left ventricular systolic dysfunction. *Eur Heart J* 2000;21:1514–1521.
11. Arakawa N, Nakamura M, Aoki H, Hiramori K. Relationship between plasma level of brain natriuretic peptide and myocardial infarct size. *Cardiology* 1994;85:334–340.
12. Nakagawa K, Umetani K, Fujioka D, et al. Correlation of plasma concentrations of B-type natriuretic peptide with infarct size quantified by tomographic thallium-201 myocardial scintigraphy in asymptomatic patients with previous myocardial infarction. *Circ J* 2004;68:923–927.
13. Cochet A, Zeller M, Cottin Y, et al. The extent of myocardial damage assessed by contrast-enhanced MRI is a major determinant of N-BNP concentration after myocardial infarction. *Eur J Heart Fail* 2004;6:555–560.
14. Choi EY, Kwon HM, Yoon YW, Kim D, Kim HS. Assessment of extent of myocardial ischemia in patients with non-ST elevation acute coronary syndrome using serum B-type natriuretic peptide level. *Yonsei Med J* 2004;45:255–262.
15. Kikuta K, Yasue H, Yoshimura M, et al. Increased plasma levels of B-type natriuretic peptide in patients with unstable angina. *Am Heart J* 1996;132:101–107.
16. Asada J, Tsuji H, Iwasaka T, Thomas JD, Lauer MS. Usefulness of plasma brain natriuretic peptide levels in predicting dobutamine-induced myocardial ischemia. *Am J Cardiol* 2004;93:702–704.
17. Sabatine MS, Morrow DA, De Lemos JA, et al. Acute changes in circulating natriuretic peptide levels in relation to myocardial ischemia. *J Am Coll Cardiol* 2004;44:1988–1995.
18. Bibbins-Domingo K, Ansari M, Schiller NB, Massie B, Whooley MA. B-type natriuretic peptide and ischemia in patients with stable coronary disease: data from the Heart and Soul study. *Circulation* 2003;108:2987–2992.
19. Weber M, Dill T, Arnold R, et al. N-terminal B-type natriuretic peptide predicts extent of coronary artery disease and ischemia in patients with stable angina pectoris. *Am Heart J* 2004;148:612–620.
20. Perhonen M, Takala TE, Vuolteenaho O, Mantymaa P, Leppaluoto J, Ruskoaho H. Induction of cardiac natriuretic peptide gene expression in rats trained in hypobaric hypoxic conditions. *Am J Physiol* 1997;273:R344–R352.
21. D'Souza SP, Yellon DM, Martin C, et al. B-type natriuretic peptide limits infarct size in rat isolated hearts via KATP channel opening. *Am J Physiol Heart Circ Physiol* 2003;284:H1592–H1600.
22. Toth M, Vuorinen KH, Vuolteenaho O, et al. Hypoxia stimulates release of ANP and BNP from perfused rat ventricular myocardium. *Am J Physiol* 1994;266:H1572–H1580.
23. Hopkins WE, Chen Z, Fukagawa NK, Hall C, Knot HJ, LeWinter MM. Increased atrial and brain natriuretic peptides in adults with cyanotic congenital heart disease: enhanced understanding of the relationship between hypoxia and natriuretic peptide secretion. *Circulation* 2004;109:2872–2877.
24. Jiang C, Lu H, Vincent KA, et al. Gene expression profiles in human cardiac cells subjected to hypoxia or expressing a hybrid form of HIF-1 alpha. *Physiol Genomics* 2002;8:23–32.
25. Goetze JP, Christoffersen C, Perko M, et al. Increased cardiac BNP expression associated with myocardial ischemia. *FASEB J* 2003;17:1105–1107.
26. Ruck A, Gustafsson T, Norrbom J, et al. ANP and BNP but not VEGF are regionally overexpressed in ischemic human myocardium. *Biochem Biophys Res Commun* 2004;322:287–291.
27. Kyriakides ZS, Markianos M, Michalis L, Antoniadis A, Nikolaou NI, Kremastinos DT. Brain natriuretic peptide increases acutely and much more prominently than atrial natriuretic peptide during coronary angioplasty. *Clin Cardiol* 2000;23:285–288.
28. Tateishi J, Masutani M, Ohyanagi M, Iwasaki T. Transient increase in plasma brain (B-type) natriuretic peptide after percutaneous transluminal coronary angioplasty. *Clin Cardiol* 2000;23:776–780.
29. Hara Y, Hamada M, Shigematsu Y, et al. Effect of patency from coronary angioplasty during acute myocardial infarction on left ventricular remodeling and levels of natriuretic peptides later. *Am J Cardiol* 2001;88:683–685.
30. Sadanandan S, Cannon CP, Chekuri K, et al. Association of elevated B-type natriuretic peptide levels with angiographic findings among patients with unstable angina and non-ST-segment elevation myocardial infarction. *J Am Coll Cardiol* 2004;44:564–568.
31. Haug C, Metzela A, Kochs M, Hombach V, Grunert A. Plasma brain natriuretic peptide and atrial natriuretic peptide concentrations correlate with left ventricular end-diastolic pressure. *Clin Cardiol* 1993;16:553–557.
32. Hellermann JP, Jacobsen SJ, Reeder GS, Lopez-Jimenez F, Weston SA, Roger VL. Heart failure after myocardial infarction: prevalence of preserved left ventricular systolic function in the community. *Am Heart J* 2003;145:742–748.

33. He KL, Dickstein M, Sabbah HN, et al. Mechanisms of heart failure with well preserved ejection fraction in dogs following limited coronary microembolization. *Cardiovasc Res* 2004;64:72–83.
34. Suzuki N, Mori H, Hazama M, Takahashi K, Moriya M, Yano K. [Relationship between brain natriuretic peptide and coronary stenosis: influence of aging]. *J Cardiol* 2004;43:117–122.
35. Casco VH, Veinot JP, Kuroski de Bold ML, Masters RG, Stevenson MM, de Bold AJ. Natriuretic peptide system gene expression in human coronary arteries. *J Histochem Cytochem* 2002;50:799–809.
36. Omland T, Bonarjee VV, Lie RT, Caidahl K. Neurohumoral measurements as indicators of long-term prognosis after acute myocardial infarction. *Am J Cardiol* 1995;76:230–235.
37. Hall C, Rouleau JL, Moye L, et al. N-terminal proatrial natriuretic factor: an independent predictor of long-term prognosis after myocardial infarction. *Circulation* 1994;89:1934–1942.
38. Omland T, Aakvaag A, Bonarjee VV, et al. Plasma brain natriuretic peptide as an indicator of left ventricular systolic function and long-term survival after acute myocardial infarction: comparison with plasma atrial natriuretic peptide and N-terminal proatrial natriuretic peptide. *Circulation* 1996;93:1963–1969.
39. Choy AM, Darbar D, Lang CC, et al. Detection of left ventricular dysfunction after acute myocardial infarction: comparison of clinical, echocardiographic, and neurohormonal methods. *Br Heart J* 1994;72:16–22.
40. Nagaya N, Nishikimi T, Goto Y, et al. Plasma brain natriuretic peptide is a biochemical marker for the prediction of progressive ventricular remodeling after acute myocardial infarction. *Am Heart J* 1998;135:21–28.
41. Nilsson JC, Groenning BA, Nielsen G, et al. Left ventricular remodeling in the first year after acute myocardial infarction and the predictive value of N-terminal pro brain natriuretic peptide. *Am Heart J* 2002;143:696–702.
42. Darbar D, Davidson NC, Gillespie N, et al. Diagnostic value of B-type natriuretic peptide concentrations in patients with acute myocardial infarction. *Am J Cardiol* 1996;78:284–287.
43. Arakawa N, Nakamura M, Aoki H, Hiramori K. Plasma brain natriuretic peptide concentrations predict survival after acute myocardial infarction. *J Am Coll Cardiol* 1996;27:1656–1661.
44. Richards AM, Nicholls MG, Yandle TG, et al. Plasma N-terminal pro-brain natriuretic peptide and adrenomedullin: new neurohormonal predictors of left ventricular function and prognosis after myocardial infarction. *Circulation* 1998;97:1921–1929.
45. de Lemos JA, Morrow DA, Bentley JH, et al. The prognostic value of B-type natriuretic peptide in patients with acute coronary syndromes. *N Engl J Med* 2001;345:1014–1021.
46. Morrow DA, de Lemos JA, Sabatine MS, et al. Evaluation of B-type natriuretic peptide for risk assessment in unstable angina/non-ST-elevation myocardial infarction: B-type natriuretic peptide and prognosis in TACTICS-TIMI 18. *J Am Coll Cardiol* 2003;41:1264–1272.
47. Omland T, Persson A, Ng L, et al. N-terminal pro-B-type natriuretic peptide and long-term mortality in acute coronary syndromes. *Circulation* 2002;106:2913–2918.
48. James SK, Lindahl B, Siegbahn A, et al. N-terminal pro-brain natriuretic peptide and other risk markers for the separate prediction of mortality and subsequent myocardial infarction in patients with unstable coronary artery disease: a Global Utilization of Strategies To Open occluded arteries (GUSTO)-IV sub-study. *Circulation* 2003;108:275–281.
49. Richards AM, Nicholls MG, Espiner EA, et al. B-type natriuretic peptides and ejection fraction for prognosis after myocardial infarction. *Circulation* 2003;107:2786–2792.
50. Jernberg T, Stridsberg M, Venge P, Lindahl B. N-terminal pro brain natriuretic peptide on admission for early risk stratification of patients with chest pain and no ST-segment elevation. *J Am Coll Cardiol* 2002;40:437–445.
51. Galvani M, Ottani F, Oltrona L, et al. N-terminal pro-brain natriuretic peptide on admission has prognostic value across the whole spectrum of acute coronary syndromes. *Circulation* 2004;110:128–134.
52. Mega JL, Morrow DA, De Lemos JA, et al. B-type natriuretic peptide at presentation and prognosis in patients with ST-segment elevation myocardial infarction: an ENTIRE-TIMI-23 substudy. *J Am Coll Cardiol* 2004;44:335–339.
53. Suzuki S, Yoshimura M, Nakayama M, et al. Plasma level of B-type natriuretic peptide as a prognostic marker after acute myocardial infarction: a long-term follow-up analysis. *Circulation* 2004;110:1387–1391.
54. Heeschen C, Hamm CW, Mitrovic V, Lantelme NH, White HD. N-terminal pro-B-type natriuretic peptide levels for dynamic risk stratification of patients with acute coronary syndromes. *Circulation* 2004;110:3206–3212.

55. Jernberg T, Lindahl B, Siegbahn A, et al. N-terminal pro-brain natriuretic peptide in relation to inflammation, myocardial necrosis, and the effect of an invasive strategy in unstable coronary artery disease. *J Am Coll Cardiol* 2003;42:1909–1916.
56. Wallentin L, Lagerqvist B, Husted S, Kontny F, Stahle E, Swahn E. Outcome at 1 year after an invasive compared with a non-invasive strategy in unstable coronary-artery disease: the FRISC II invasive randomised trial. FRISC II Investigators. *Fast Revascularisation During Instability in Coronary Artery Disease*. *Lancet* 2000;356:9–16.
57. Cannon CP, Weintraub WS, Demopoulos LA, et al. Comparison of early invasive and conservative strategies in patients with unstable coronary syndromes treated with the glycoprotein IIb/IIIa inhibitor tirofiban. *N Engl J Med* 2001;344:1879–1887.
58. Sabatine MS, Morrow DA, de Lemos JA, et al. Multimarker approach to risk stratification in non-ST elevation acute coronary syndromes: simultaneous assessment of troponin I, C-reactive protein, and B-type natriuretic peptide. *Circulation* 2002;105:1760–1763.
59. Wylie JV, Murphy SA, Morrow DA, de Lemos JA, Antman EM, Cannon CP. Validated risk score predicts the development of congestive heart failure after presentation with unstable angina or non-ST-elevation myocardial infarction: results from OPUS-TIMI 16 and TACTICS-TIMI 18. *Am Heart J* 2004;148:173–180.
60. Bazzino O, Fuselli JJ, Botto F, Perez De Arenaza D, Bahit C, Dadone J. Relative value of N-terminal probrain natriuretic peptide, TIMI risk score, ACC/AHA prognostic classification and other risk markers in patients with non-ST-elevation acute coronary syndromes. *Eur Heart J* 2004;25:859–866.



# 25

---

## Novel Markers of Hemodynamic Stress

---

*Ellen O. Weinberg, PhD  
and Richard T. Lee, MD*

### CONTENTS

INTRODUCTION
ST2
ADRENOMEDULLIN
UROCORTIN
UROTENSIN
MYOTROPHIN
NOVEL CANDIDATE MARKERS OF HEMODYNAMIC STRESS
CONCLUSION
REFERENCES

---

### SUMMARY

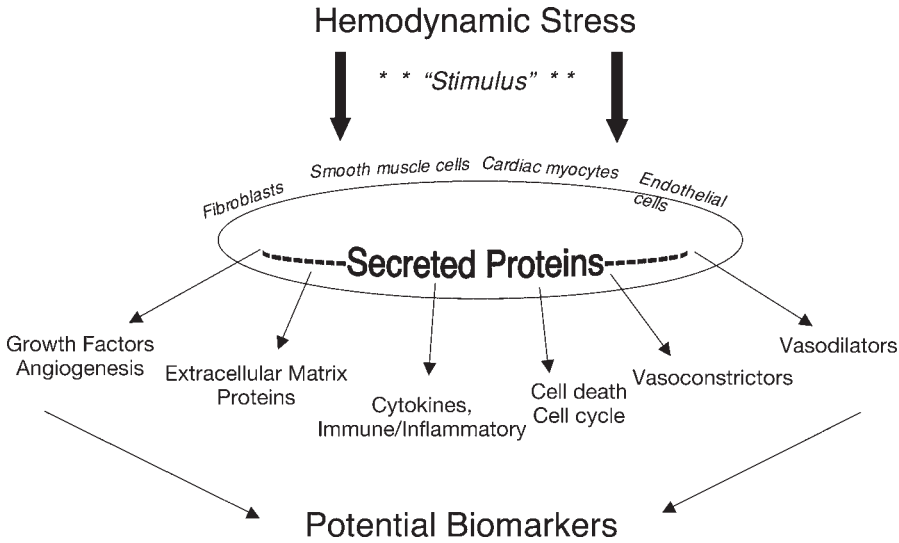
A marker of hemodynamic stress is a secreted molecule that is induced by hemodynamic stress, regardless of its function or mechanism of action. In this chapter, we describe the interleukin-1 receptor family member ST2, a novel biomarker of hemodynamic stress in acute myocardial infarction and heart failure. We also discuss other novel hemodynamic markers—adrenomedullin, urocortin, urotensin, and myotrophin—which are currently being evaluated in the clinical setting. Finally, we describe the usefulness of applying the genomics approach to a well-characterized *in vivo* animal model of hemodynamic stress, a discovery strategy for identifying novel biomarkers.

**Key Words:** Biomarker; myocardial infarction; heart failure; hemodynamic stress; genomics; interleukin-1 receptor; adrenomedullin; urocortin; urotensin; myotrophin.

### INTRODUCTION

To be considered a marker of hemodynamic stress, a molecule either must be induced by hemodynamic stress *in vitro* or *in vivo* or correlate with hemodynamic parameters *in vivo* and be detected in readily accessible body fluids such as plasma/serum or urine

From: *Contemporary Cardiology:  
Cardiovascular Biomarkers: Pathophysiology and Disease Management*  
Edited by: David A. Morrow © Humana Press Inc., Totowa, NJ



**Fig. 1.** Hemodynamic stress is a stimulus for the production of secreted proteins from several functional classes; when detected in plasma/serum, they are potential biomarkers of hemodynamic stress.

(Fig. 1). Many biomarkers of hemodynamic stress are secreted molecules that not only are induced by hemodynamic stress, but also have hemodynamic effects themselves. Thus, the biomarker represents hemodynamic state because it is induced for a compensatory function (often reduction in blood pressure [BP]). Regardless of its function or mechanism of action, a hemodynamic biomarker must be sufficiently stable that it can be detected during or shortly after the change in hemodynamic state.

Specificity is a critical issue with any biomarker, because predictive value will depend on specificity. Thus, we do not discuss herein molecules that are released from injured cells owing to loss of cell membrane integrity (e.g., fatty acid-binding proteins, heat-shock proteins, biopyrrin) or that might be induced by hemodynamic stress *in vitro* but are already well-established immune/inflammatory mediators of the cardiovascular system (e.g., CD40/CD40 ligand, interleukin [IL]-6, leukemia inhibitory factor, gp130, FAS/FAS ligand) and thus are unlikely to reflect hemodynamic state specifically.

It is logical that some biomarkers of hemodynamic overload are themselves vasodilators or diuretics. To achieve BP hemostasis, an increase in arterial or venous pressures may be relieved by vasodilation or loss of intravascular volume. B-type natriuretic peptide (BNP) is the prototypical example of this group of biomarkers and has established the clinical relevance of hemodynamic biomarkers as a class. However, it is important to recognize that when hemodynamic state changes, multiple cardiac intracellular pathways are activated. Thus, the “hemodynamic defense reaction” (1), i.e., the response of the heart to hemodynamic overload, is not restricted to pathways that restore hemodynamic homeostasis. Neurohormonal-, inflammatory/immune-, growth-associated-, and cell-death-regulating mediators contribute to the short- and long-term responses to hemodynamic overload. Therefore, potential biomarkers of hemodynamic state and disease progression include many proteins outside the realm of vasomotion and diuresis, and new markers are likely to emerge from the laboratory as researchers further their understanding of how the heart responds to a change in mechanical stress.

This chapter begins with a description of ST2, a gene responsive to mechanical load in cardiac myocytes *in vitro* and a promising biomarker in acute myocardial infarction (AMI) and heart failure. Other novel hemodynamic markers discussed here are adrenomedullin, urocortin, urotensin, and myotrophin, which are currently being evaluated in the clinical setting. Finally, we describe why it is useful to apply the genomics approach to a well-characterized *in vivo* animal model of hemodynamic stress, a discovery strategy for identifying novel biomarkers.

## ST2

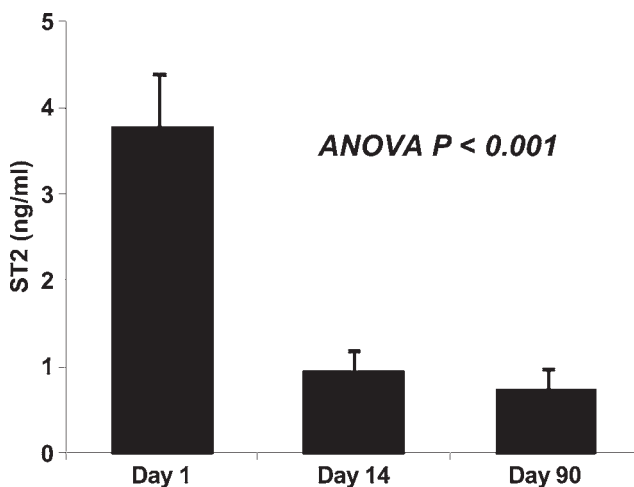
The mechanically regulated protein ST2 (also called IL-1 receptor-like-1) is a member of the IL-1 receptor family (2). The soluble form of ST2 contains a signal sequence enabling its secretion from cells and it is readily detected in human blood. Two additional forms of ST2 have also been identified—a larger membrane-anchored form consisting of the identical extracellular region to soluble ST2 joined to a membrane-spanning region and an intracellular domain (ST2L), and a third product called ST2V, which is similar to ST2L but lacks the intracellular domain. Unlike its cousin, the IL-1 receptor, no ligand has yet been identified for ST2, and ST2 does not bind any of the ILs (3,4). The IL-1 receptor family, together with the toll receptor family, belongs to a larger superfamily of proteins that all contain a conserved sequence in the cytoplasmic domain called the Toll-IL1R (TIR) domain. All members of this receptor superfamily may participate in the activation of signaling pathways through the TIR domain that lead to the induction of immune and inflammatory responses through the transcription factor nuclear factor- $\kappa$ B (NF- $\kappa$ B) and the mitogen-activated protein kinases (MAPKs) p38, JNK, and ERK1/2 (5).

### *Biological Functions of ST2*

Although first identified as a growth-associated protein in fibroblasts, recent studies have shown that soluble ST2 regulates the inflammatory response. Sweet et al. (6) showed that treatment with recombinant soluble ST2 suppressed inflammatory cytokine production (IL-6, IL-12, and tumor necrosis factor [TNF]- $\alpha$ ) in macrophages activated with the bacterial toxin lipopolysaccharide (LPS). LPS activates macrophages via engagement of toll-like receptor 4 (TLR4) with its coreceptor, CD14, inducing the production of proinflammatory responses; soluble ST2 suppresses expression of TLR4 (6). These results suggest that one mechanism by which ST2 inhibits LPS-induced proinflammatory cytokine production is by counteracting the effects of TLR4 signaling. This study also showed that soluble ST2 counteracts endotoxic shock *in vivo* produced by LPS, resulting in improved survival and lower levels of serum IL-6, IL-12, and TNF- $\alpha$  in the mouse. Conversely, anti-ST2 antibody, which neutralized ST2, exacerbated LPS-mediated mortality and enhanced the production of proinflammatory cytokines (6). Thus, ST2 appears to dampen inflammatory responses. Macrophages from ST2-deficient mice produce significantly more IL-6 and IL-12 in response to treatment with IL-1 $\beta$  and LPS compared with macrophages from wild-type mice (7). Overexpression of ST2 in cultured cells downregulates IL-1 receptor signaling. Since IL-1 induces the expression of many genes involved in the inflammatory response, these results suggest that ST2 has the ability to counteract this response by exerting a negative regulatory function on IL-1 receptor signaling.

The therapeutic potential of soluble ST2 was demonstrated recently in a study in which soluble ST2 suppressed the progression of murine collagen-induced arthritis in association with reduced levels of IL-12, TNF- $\alpha$ , IL-6, and interferon- $\gamma$  (8). Yanagisawa and





**Fig. 2.** ST2 protein levels in circulation of human patients after MI. Serial blood samples from 69 patients from the HEART study were analyzed for ST2 by enzyme-linked immunosorbent assay. ST2 was significantly increased on d 1 after MI compared with d 14 and d 90. ANOVA, analysis of variance. (Reproduced from ref. 15.)

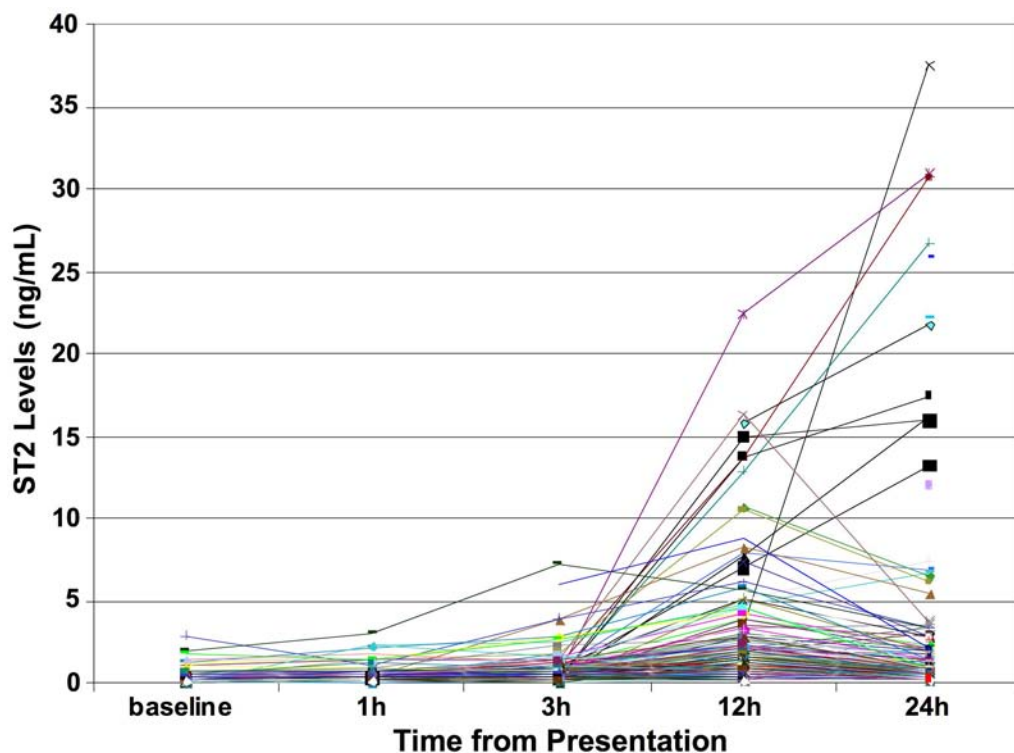
colleagues showed that membrane-anchored ST2 (ST2L) mRNA was expressed in mouse T helper type 2 (Th2) cells but not Th1 cells (9,10). This finding was confirmed by others (10–13). Hence, ST2L appears to be a marker of Th2 cells.

### *ST2 in Cardiovascular Diseases*

In studies searching for new genes induced by mechanical stress, we used DNA microarray technology to identify ST2 as a gene markedly induced by cyclic mechanical strain in cultured cardiac myocytes. This system models on a cellular level the increase in ventricular stress imposed on the myocardium during hemodynamic overload (14). Northern analysis confirmed the DNA microarray result demonstrating rapid induction of ST2 mRNA (within 1 h) in cultured cardiac myocytes subjected to mechanical strain sustained for 15 h (15). In addition to mechanical strain, IL-1 $\beta$  and phorbol ester, but not LPS (a ligand for the toll receptor) or TNF- $\alpha$ , induced ST2 mRNA, suggesting selectivity for the induction of ST2 in cardiac myocytes.

### *ST2 in MI*

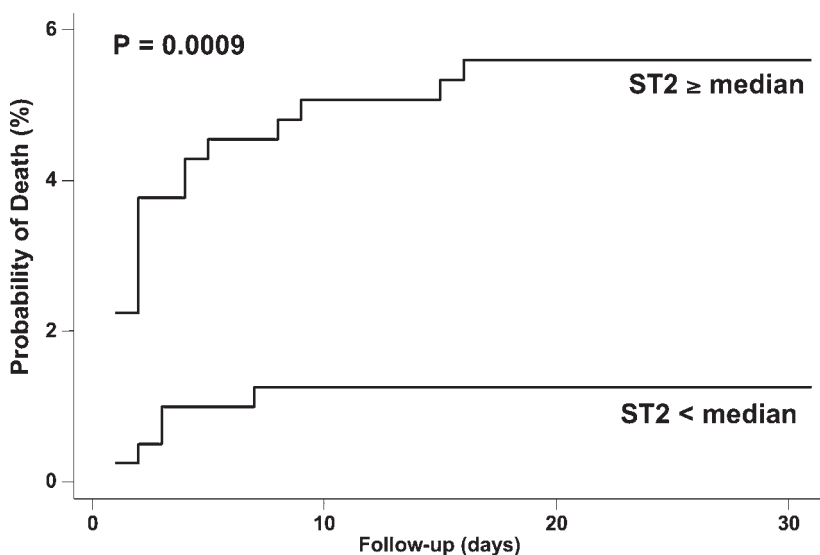
Based on our in vitro findings in cultured cardiac myocytes, and because ST2 is a secreted protein that is detected in human serum (16), we hypothesized that serum levels of ST2 may be elevated in patients following MI, a condition in which the remaining viable myocardium bears additional hemodynamic stress. Serum ST2 levels were measured on d 1, 14, and 90 after MI in patients enrolled in the Healing and Early Afterload Reducing Trial (HEART) (15). HEART evaluated the safety and effectiveness of the angiotensin-converting enzyme inhibitor ramipril beginning on d 1 vs d 14 after MI (17–19). Circulating serum ST2 levels were elevated on d 1 after MI compared with d 14 and 90 ( $p < 0.001$ ) (Fig. 2). Serum ST2 levels on d 1 correlated inversely with echocardiographic ejection fraction, suggesting an association between hemodynamic stress and ST2 levels. In addition, ST2 levels correlated positively with creatine kinase, a marker of cellular injury postinfarction.



**Fig. 3.** Evolution of ST2 serum levels over 24 h after presentation for AMI. Each line represents 1 of 228 patients in TIMI 14 study who had serum samples available at all five time points. Peak values occurred at 12 h in most patients, although some patients with particularly high levels had peak values at 24 h. (Reproduced from ref. 20.)

To determine the relationship between ST2 serum levels and clinical outcome in AMI, we assayed serum for ST2 from patients with ST-elevation MI enrolled in the Thrombolysis in Myocardial Infarction (TIMI 14) and ENTIRE (TIMI 23) trials (20). TIMI 14 evaluated the combination of fibrinolytics with abciximab, a glycoprotein IIb/IIIa antagonist (21,22). Serum samples were available at 1, 3, 12, and 24 h after enrollment. TIMI 23 was designed to evaluate the low molecular weight heparin enoxaparin as adjunctive anti-thrombin therapy with various forms of pharmacological reperfusion (23). Serum samples were available at baseline (enrollment). Measurement of ST2 in TIMI 14 showed that although ST2 serum concentration is elevated at the time of presentation in patients with MI compared with healthy subjects, peak levels are achieved 12 h after presentation and begin to decline by 24 h in most patients (Fig. 3). This observation is useful for understanding the potential of ST2 as a marker of hemodynamic stress in AMI and is in agreement with the rapid induction of ST2 mRNA expression in cultured cardiac myocytes.

Interestingly, higher baseline ST2 levels were associated with adverse clinical outcome at 30 d. Dichotomized at the median, elevated levels of ST2 were associated with higher mortality through 30 d of follow-up ( $p = 0.0009$ ) (Fig. 4), and the risk of death or combined death/heart failure increased in a stepwise fashion according to quartiles of ST2. In multivariable analysis that included traditional indicators of risk in AMI, increasing concentration of ST2 was an independent predictor of death at 30 d. Establishing ST2 as a novel



**Fig. 4.** Probability of death through 30 d after presentation with STEMI stratified by serum ST2 level at baseline. (Reproduced from ref. 20.)

biomarker that offers prognostic information in patients with AMI. The findings also suggest a potential role for ST2 to modulate the inflammatory response following hemodynamic stress after MI.

### *ST2 and Heart Failure*

Although ST2 is a promising biomarker in AMI, this does not necessarily demonstrate that it may be reflecting hemodynamic state, because the inflammation of infarction could induce ST2. Thus, we evaluated ST2 as a biomarker in patients with nonischemic chronic heart failure in the Prospective Randomized Amlodipine Survival Evaluation 2 (PRAISE-2) trial (24). This trial evaluated the effects of amlodipine on survival in patients with severe nonischemic chronic heart failure. Serum samples were available at baseline (trial enrollment) and 2 wk after enrollment from 161 patients with New York Heart Association (NYHA) functional class III–IV in the neurohormone substudy.

Serum levels of ST2 were significantly higher in patients with heart failure compared with control subjects ( $p < 0.0001$ ). The baseline concentration of ST2 correlated positively with baseline BNP, pro atrial natriuretic peptide (proANP), and norepinephrine (all  $p < 0.0001$ ). ST2 concentration at baseline, and the change in ST2 concentration from baseline to 2 wk (ST2 levels increasing during 2 wk), were evaluated in multivariable analysis for significance as independent predictors of the primary end point (death or transplantation). When baseline BNP or proANP was included in the model, baseline ST2 was not an independent predictor of death or transplantation. However, change in ST2 was a significant independent predictor of outcome when either BNP or proANP was in the model. These results suggest that the change in ST2 has prognostic value independent of BNP and proANP in patients with severe heart failure.

Although these studies suggest that overloaded cardiac myocytes are the cellular source of circulating ST2 in patients with severe heart failure, human serum studies cannot prove this. Heart failure can cause both neurohormonal and cytokine activation, and it is possible

that other cell types secrete ST2 in chronic heart failure. However, based on the correlations of serum levels of ST2 with BNP and proANP, we speculate that ST2 induction is coordinated with hemodynamic status in patients with severe heart failure. The PRAISE-2 study was limited to patients with severe heart failure (NYHA class III–IV) and, therefore, the prognostic significance of ST2 in mild chronic heart failure remains to be determined. However, ST2 appears promising as a hemodynamic biomarker, and broader studies to determine its incremental prognostic benefit are needed.

## ADRENOMEDULLIN

Adrenomedullin was first isolated from human pheochromocytomas and is a 52 amino acid peptide with structural homology to calcitonin and calcitonin gene–related peptide. After it was first isolated, adrenomedullin was discovered to be widely distributed in various peripheral tissues as well as in the central and peripheral nervous systems. Adrenomedullin has potent vasodilatory actions. Adrenomedullin signaling is coupled to adenylate cyclase, nitric oxide (NO), and cyclic guanosine 5'-monophosphate mechanisms through receptor complexes including two seven-transmembrane domain proteins known as CTR and CRLR, three single-transmembrane domain proteins termed RAMPs, and an intracellular protein called RCT. Positive immunoreactivity for adrenomedullin is found in cardiomyocytes, vascular smooth muscle cells (VSMCs), and vascular endothelial cells (ECs) in addition to cell types in the digestive, respiratory, and endocrine systems (25,26).

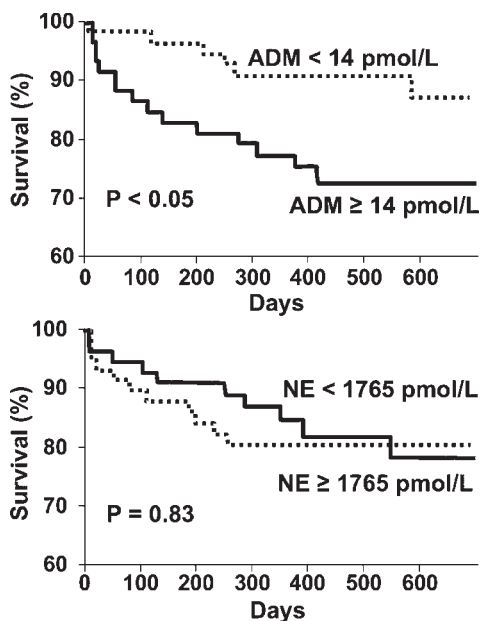
### *Induction and Secretion of Adrenomedullin*

The 21 amino acid signal peptide of the adrenomedullin protein indicates that adrenomedullin is a secreted protein, and it has been shown that cultured vascular ECs, smooth muscle cells (SMCs), cardiac myocytes, and cardiac fibroblasts all can secrete adrenomedullin (27,28). Adrenomedullin mRNA is regulated by shear stress in cultured human endothelial cells (29,30) and is also upregulated by mechanical stretch in cultured cardiac myocytes (31). In addition to hemodynamic stress, IL-1 $\beta$ , TNF- $\alpha$ , and phorbol ester can induce the secretion of adrenomedullin in cultured VSMCs, ECs, cardiac myocytes, and fibroblasts (28,32).

### *Effects of Adrenomedullin*

Exogenously administered adrenomedullin is mitogenic to cultured aortic VSMCs through p42/p44 ERK/MAPK pathway activation (33). Endogenous adrenomedullin secreted from cultured cardiac myocytes inhibits myocyte hypertrophy, demonstrating that it may act in an autocrine and/or a paracrine manner (31). In addition to effects on cell growth and hypertrophy, adrenomedullin promotes IL-6 secretion and attenuates endothelin-1 (ET-1) secretion from fibroblasts but not myocytes, as well as augments cyclic adenosine monophosphate (cAMP) production in response to IL-1 $\beta$  (28). Adrenomedullin induces the secretion of IL-6 from cultured fibroblasts through a cAMP-mediated pathway and augments the TNF- $\alpha$  and IL-1-induced secretion of IL-6 and NO production (27). When administered *in vivo* directly into the coronary artery of instrumented sheep, adrenomedullin causes sustained coronary vasodilation, which is abolished with intracoronary infusion of *N*-nitro-L-arginine, a NO synthase inhibitor, demonstrating that the coronary vasodilation in response to adrenomedullin is mediated by the release of NO from ECs (34).

Several studies have shown that plasma adrenomedullin concentrations are increased in patients with AMI (35–37), chronic heart failure (38), and hypertension (39), indicat-



**Fig. 5.** Kaplan-Meier survival curves for subgroups with early postinfarction plasma peptide (adrenomedullin [ADM] and norepinephrine [NE]) concentrations above (solid lines) and below (dashed lines) group median in 121 patients with MI. (Reproduced from ref. 37.)

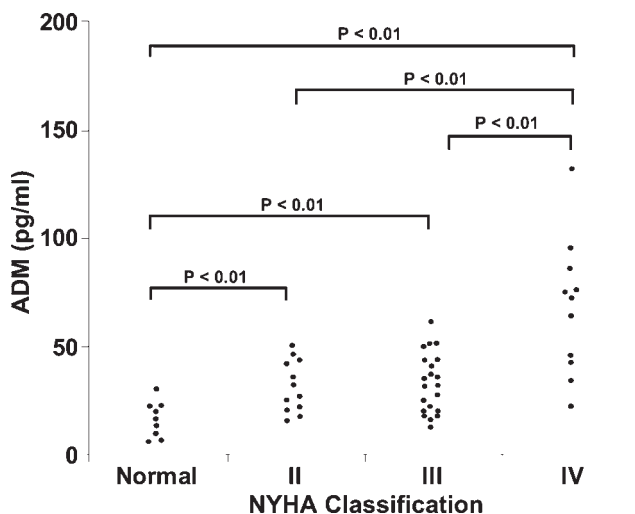
ing the potential usefulness of adrenomedullin as a biomarker in conditions of hemodynamic stress.

### *Adrenomedullin and MI*

Plasma adrenomedullin is increased early during AMI (35–37). Similar to ANP and BNP, plasma adrenomedullin levels are elevated at admission in patients with MI compared with healthy control subjects, peak at 24 h after MI, and decline at 4 wk to levels that are still above normal (35). The concentration of adrenomedullin is negatively correlated with left ventricular ejection fraction (LVEF), suggesting a relationship between adrenomedullin and hemodynamic status postinfarction. Adrenomedullin is a significant predictor of mortality (Fig. 5) but is less strongly associated with outcome than N-terminal proBNP (NT-proBNP) and BNP (37).

### *Adrenomedullin and Heart Failure*

The plasma concentration of adrenomedullin is increased in patients with heart failure in relation to NYHA classification (40,41) (Fig. 6). Plasma adrenomedullin levels positively correlate with plasma ANP levels and with LV end-diastolic pressure (LVEDP). Blood sampling in a subset of patients with heart failure undergoing cardiac catheterization revealed a modest but significant 20% increase in adrenomedullin concentration between the aorta and the anterior interventricular vein and between the aorta and the coronary sinus, whereas the increase in ANP concentrations in the same patients was between 200 and 300%. These results show that the failing heart secretes adrenomedullin; however, adrenomedullin is also synthesized in the vasculature of the lower extremities (25). It is likely that the heart is not the only source of elevated plasma adrenomedullin in heart failure. In a study by Pousset et al. (42), the plasma concentration of adrenomedullin was a signifi-



**Fig. 6.** Adrenomedullin (ADM) concentration in healthy control subjects and in patients with congestive heart failure according to NYHA classification. (Reproduced from ref.40.)

cant predictor of outcome (death or cardiac transplantation) in patients with heart failure with a range of NYHA functional classes and different etiologies. Moreover, plasma adrenomedullin was an independent predictor of outcome in multivariable models in which the only other independent predictors were ET-1 and systolic BP (BNP was not measured in this study).

In a study by Richards et al. (43), adrenomedullin and NT-proBNP were evaluated for prognostic utility in patients with LV dysfunction, and for their ability to predict benefit from treatment with the  $\beta$ -blocker carvedilol in patients with chronic, stable heart failure of ischemic etiology (NYHA class II–III). Prerandomization plasma levels of both adrenomedullin and NT-proBNP that were above the median were more robust than ejection fraction in predicting all-cause mortality, heart failure mortality, and worsening heart failure. Both adrenomedullin and NT-proBNP were independent predictors of outcomes. More important, this study also showed that elevated adrenomedullin (as well as NT-proBNP) levels prior to treatment with carvedilol were associated with a benefit from the addition of the  $\beta$ -blocker.

Infusion of adrenomedullin in patients with heart failure and in healthy subjects decreases mean arterial pressure and increases cardiac index in both groups and decreases pulmonary capillary wedge pressure and pulmonary arterial pressure in patients with heart failure (44). Adrenomedullin also increases urine volume and urinary sodium excretion, with a decline in plasma aldosterone concentration in patients with heart failure. These results suggest that adrenomedullin, in addition to its usefulness as a biomarker, may be of potential therapeutic benefit in heart failure.

## UROCORTIN

Urocortin is a 40 amino acid peptide that was discovered in rat brain by DNA homology screening with a probe derived from fish urotensin (45). Urocortin is highly homologous to the hypothalamic hormone corticotropin-releasing factor (CRF). The mRNA for urocortin encodes a protein of 122 amino acids that contains a signal peptide, indicating that

it is a secreted protein. The protein is processed by proteolytic cleavage to yield the active 40 amino acid peptide urocortin.

### *Effects of Urocortin*

Because of its similarity to CRF, the first studies on urocortin focused on its possible effects in the stress response through the hypothalamic–pituitary–adrenal axis. However, studies of receptor affinities and subtype distributions revealed that although CRF and urocortin both bind to two receptors (CRF-R1 and CRF-R2) corticotropin-releasing factor has 10 times greater affinity for CRF-R1 and urocortin has 40 times greater affinity for CRF-R2. In addition, CRF-R2 is further subtyped into CRF-R2 $\alpha$  and CRF-R2 $\beta$ , which are both predominantly localized in the periphery, in particular the myocardium and vasculature, and CRF-R2 $\gamma$ , which may be predominantly localized in the central nervous system (46–48). The high affinity of urocortin to CRF-R2 receptors and the identification of both in the cardiovascular system have generated interest in the study of urocortin, a peripherally circulating peptide, as a biomarker for hemodynamic regulation and cardiac function.

Urocortin has vasodilatory as well as positive inotropic and chronotropic effects when administered *in vivo*. In conscious, chronically instrumented healthy sheep, *iv* administration of urocortin produced a rapid and profound increase in cardiac contractility and coronary blood flow and a slower-developing increase in mean arterial pressure, heart rate, and cardiac output. Plasma renin was significantly reduced and plasma adrenocorticotropic hormone and cortisol were increased (49). When administered *in vivo* to healthy mice, urocortin caused an increase in cardiac circumferential shortening, an increase in heart rate, and a decrease in mean arterial pressure. Urocortin given by infusion to healthy humans at a dose that had no hemodynamic effects significantly increased plasma levels of ANP (50).

### *Urocortin Expression in the Cardiovascular System*

Urocortin mRNA is expressed in cultured cardiac myocytes (51,52). The mRNA for the peripheral receptor for urocortin, CRF-R2 $\beta$ , is much more abundantly expressed in cardiac myocytes than in fibroblasts (52). CRF-R receptors are G protein-coupled receptors (GPCRs), and their activation results in an increase in cAMP and activation of protein kinase A. Urocortin treatment of cultured cardiac myocytes stimulates cAMP production through CRF-R2 $\beta$  signaling (48,52,53). Cultured neonatal rat cardiac myocytes and fibroblasts secrete urocortin protein constitutively, with the production level of urocortin two-fold higher in fibroblasts than in myocytes (54). No studies are available describing the *induced* secretion of urocortin in cultured cells. Two additional effects of urocortin in cardiac myocytes are important. Urocortin causes a significant increase in ANP and BNP secretion and increases protein synthesis ( $^3\text{H}$  amino acid incorporation) in cultured cardiac myocytes (52,53), suggesting that urocortin promotes cardiac myocyte hypertrophy and demonstrating a novel pathway by which ANP and BNP may be elevated *in vivo*.

Urocortin mRNA levels are increased whereas CRF-R2 $\beta$  receptor mRNA levels are depressed in left ventricles from rats with mineralocorticoid excess-induced LV hypertrophy (DOC-salt model) (52,53). This model of LV hypertrophy is characterized by severe systemic hypertension and neurohormonal-adrenal activation. Studies of urocortin/CRF-R2 $\beta$  regulation in other models of pressure overload hypertrophy are needed to distinguish between its regulation by hemodynamic load *per se* and by neurohormonal factors.

Urocortin immunohistochemical staining is more intense in heart tissue from patients with dilated and hypertrophic cardiomyopathy compared with healthy hearts (52,55).

Reverse transcriptase polymerase chain reaction analysis in healthy human heart samples from patients who died of noncardiovascular causes revealed mRNA expression of urocortin in all four cardiac chambers. The mRNA expression of CRF-R2 $\beta$  was clearly observed in human atrial tissue but was very low in ventricular tissue, whereas CRF-R2 $\alpha$  mRNA expression was observed in all four cardiac chambers (56). These findings suggest the existence of a human heart autocrine or paracrine urocortin/CRF-R system and also suggest that in humans, in contrast to rodents, CRF-R2 $\alpha$  may be the functional receptor for urocortin in the cardiovascular system. Additional work is needed to clarify receptor subtype switching in human hearts in cardiovascular diseases (CVDs) and hemodynamic loading.

A splice variant of urocortin called urocortin III was recently detected in healthy human heart tissue. Urocortin III was also detected in healthy human plasma and urine (five times higher than plasma), as well as in kidney, brain, and lung (57). These results have generated interest in the study of the urocortin peptide family and their receptors, and of their detection in plasma in conditions of hemodynamic stress such as MI and heart failure.

### *Urocortin and Heart Failure*

The hemodynamic effects of iv administration of urocortin were studied in two models of experimental heart failure. In pacing-induced heart failure in sheep (58), cardiac output was severely depressed, and total peripheral resistance and left atrial pressure were severely elevated. Intravenous injection of urocortin increases cardiac output in a dose-dependent fashion and decreases total peripheral resistance and left atrial pressure. In sheep with heart failure, urocortin reduced plasma arginine vasopressin, renin, aldosterone, ET-1, angiotensin II, ANP, and BNP—effects that lasted until the following day—with concurrent increases in urine volume, urine sodium excretion, and creatinine excretion; notably, these effects of urocortin were not observed in healthy sheep. In a mouse model of dilated cardiomyopathic heart failure, iv injection of urocortin increased ejection fraction and improved cardiac relaxation (59). These results suggest that urocortin has beneficial hemodynamic and renal effects in heart failure.

One study has reported elevated plasma levels of urocortin in patients with heart failure (60). The study consisted of 119 patients with heart failure and 212 control subjects. The predominant etiologies of heart failure were ischemic and dilated cardiomyopathy. Plasma urocortin was most elevated in patients with NYHA class I and II and less elevated in patients with NYHA class III–IV. This finding must be interpreted with caution because NYHA class III–IV patients were older, and age was inversely associated with urocortin levels in this population. When age matched, urocortin plasma levels were still elevated in patients with heart failure vs healthy subjects. The incorporation of urocortin into logistic models improved specificity for the detection of early heart failure when used in combination with NT-proBNP. It is also uncertain whether urocortin enhances cardiac contractility at the early stages of heart failure only to be depleted in severe heart failure, contributing to the decline in cardiac function. The source of increased plasma urocortin in heart failure is not known. To date, there are no reports on plasma levels of urocortin following AMI in humans.

### *Other Effects of Urocortin*

In addition to its hemodynamic and renal effects, urocortin and its signaling through the CRF-R2 receptor have documented effects on angiogenesis/vasculogenesis, cardioprotection



following ischemia-reperfusion injury, inflammatory and immune modulation, and induction of the secretion of other active peptides. Interestingly, the CRF-R2 receptor appears to inhibit vascularization (61). Blood vessel density and diameter are profoundly increased in adult CRF-R2 null mice. Urocortin decreases the release of vascular endothelial growth factor (VEGF) and inhibits cell proliferation in VSMCs. Urocortin also decreases the number and size of capillary-like tubes in endothelial cells embedded in collagen gels and inhibits growth factor-induced vascularization in vivo.

Treatment of cultured cardiac myocytes with urocortin II and urocortin III protected myocytes from ischemia-reperfusion injury through phosphorylation and activation of the ERK1/2 p42/44 MAPK pathway (62,63). Urocortin decreases TNF- $\alpha$  and IL- $\beta$  serum levels following administration of LPS in mice, suggesting an anti-inflammatory effect (64), and enhances expression of cardiotrophin-1, a cytokine that participates in the growth and survival of cardiac myocytes (65).

Urocortin stimulates activin A secretion in cultured placenta cells (66). Activin A is a secreted glycoprotein belonging to the transforming growth factor- $\beta$  family, and activin A serum levels are increased in patients with heart failure and correlate with cardiac index, LVEDP, proANP, proBNP, C-reactive protein, and TNF- $\alpha$  (67). Activin A is therefore another potential hemodynamic biomarker that may be related to the urocortin system in heart failure.

## UROTENSIN

The receptor for urotensin was identified before urotensin itself was identified as its ligand. Ames et al. (68) screened a human genomic library with a probe to a rat orphan GPCR termed GPR14 and isolated the human homolog. Human GPR14 was abundantly expressed in the heart and pancreas and also expressed in arterial, endothelial, and SMCs, as well as brain (68). Cells transfected with human GPR14 were used to search for a ligand that produced a calcium-mobilization response (a conserved response among GPCRs). The only compound to elicit this response was goby fish urotensin, a neuropeptide first isolated from the spinal cord of the goby fish. Homology database searching matched goby fish urotensin to a human DNA sequence that, based on functional studies, was assigned as human urotensin, and GPR14 was assigned as the urotensin II receptor. Preprourotensin is a peptide that contains a signal sequence, and, thus, it is a secreted protein.

Human urotensin produces contractions in rat thoracic aorta but has no vasopressor activity in rats on iv administration in vivo. In nonhuman primate arterial vessels, urotensin is approx 10 times more potent than ET-1 in its contractile profile. When administered in vivo to nonhuman primates, urotensin causes an unusual hemodynamic profile that distinguishes it from ET-1 and angiotensin II. Urotensin causes a massive increase in total peripheral resistance indicative of systemic vasoconstriction and an increase in LVEDP, and marked contractile dysfunction (decreases in stroke volume,  $+dP/dt$ , and cardiac output) as well as a small decrease in mean arterial pressure. Urotensin also causes ST-segment changes indicative of myocardial ischemia (68). Thus, the identification of urotensin as a potent, secreted vasoconstrictor peptide and its GPCR has generated interest in their expression and hemodynamic regulation in CVD.

### *Urotensin Expression in Hypertension and Heart Failure*

A high density of urotensin receptors is found in the smooth muscle layer of coronary arteries and LV myocytes (69). Urotensin is approx 50 times more potent than ET-1 in

contracting human coronary, mammary, and radial arteries in responding tissue; however, some samples fail to respond to urotensin but are reactive toward ET-1 (69). These results demonstrate binding of urotensin to the urotensin receptor in the human vasculature. Urotensin gene expression is abundant in the human kidney and atrium and throughout the vasculature (70). Urine levels of urotensin are significantly higher in hypertensive compared with normotensive individuals and suggest that the kidney may produce urotensin in hypertension. A role for urotensin in essential hypertension has been confirmed in a study by Cheung et al. (71), which showed that plasma levels of urotensin are significantly higher in hypertensive patients compared with normotensive subjects and correlate with systolic BP.

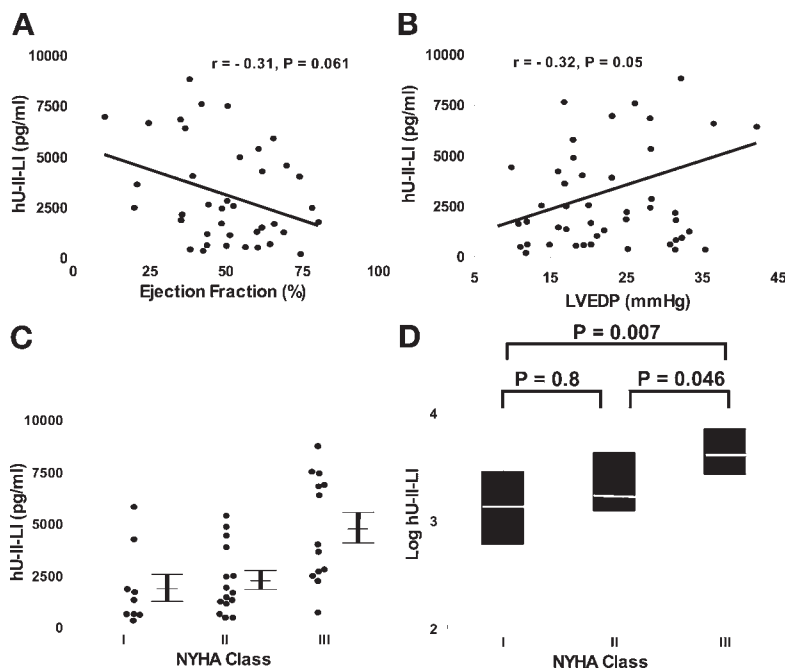
Urotensin receptor gene expression increases in the heart 1 wk after experimental myocardial infarct in the rat compared with sham-operated controls (72). Positive staining for urotensin receptors is found in myocytes, ECs, and fibroblasts in the postinfarcted heart, and positive staining for urotensin is found in the infarcted region. This suggests a role for urotensin signaling in the remodeling process post-MI. Positive staining for urotensin protein is also observed in the myocardium of patients with end-stage heart failure (73). Staining is stronger in subendocardial myocytes compared with the subepicardium or midmyocardium. Furthermore, in patients with heart failure secondary to ischemic heart disease, urotensin immunoreactivity was significantly greater in the left ventricle compared with the right ventricle or atrial tissue. Urotensin protein expression positively correlates with LV end-diastolic dimension and inversely correlates with ejection fraction (both  $p < 0.001$ ). Binding studies with labeled urotensin reveal a greater density of urotensin receptors in cardiac myocytes, ECs, and SMCs of hearts with end-stage failure compared with controls. These results were confirmed at the mRNA level for both urotensin and urotensin receptors, indicating that urotensin expression is upregulated in the hearts of patients with end-stage failure.

Plasma urotensin is increased in patients with NYHA class IV heart failure and correlates with plasma levels of ET-1 and adrenomedullin but not with angiotensin II, aldosterone, or norepinephrine (74). In patients with coronary artery disease (CAD), plasma urotensin correlates with NYHA class and LVEDP (75) (Fig. 7). Plasma aortic root urotensin levels are markedly elevated in patients with heart failure compared with patients with CAD and nonfailing hearts and inversely correlate with LVEF. Plasma levels in the aortic root are three- to fourfold higher than from the femoral artery, femoral vein, or pulmonary artery, suggesting cardiopulmonary production of urotensin in heart failure (76). In patients with CAD, Heringlake et al. (77) observed elevated urotensin levels in patients with elevated filling pressures and with three-vessel disease compared with both healthy subjects and patients with less severe disease and lower filling pressures. Urotensin levels were also significantly correlated to NT-proANP and NT-proBNP in this patient population.

Plasma urotensin levels are elevated in patients with heart failure but are unchanged with increasing NYHA class (78). Both plasma urotensin and BNP are independent predictors of NYHA class I heart failure (78).

### *Function of Urotensin*

The contractile effects of urotensin vary in different species and vascular beds (79–82). Lim et al. (83) observed that urotensin mediated a dose-dependent vasodilation in healthy subjects but that a dose-dependent vasoconstriction occurred in patients with



**Fig. 7.** Correlation of human urotensin II-like immunoreactivity (hU-II-LI) with (A) LVEF and (B) LVEDP. Shown are the raw data. Pearson's correlation coefficient was calculated with log-transformed hU-II-LI values (A,B). (C) hU-II-LI in different NYHA classes. Raw data with the mean  $\pm$  SEM next to the column scatters are presented. (D) Box plots with log-transformed hU-II-LI for different NYHA classes. The results of group comparison are shown. NYHA IV is not included because there was only one patient. (Reproduced from ref. 75.)

heart failure when urotensin was iontophoresed to the skin microvasculature, suggesting that urotensin may contribute to increased peripheral vascular resistance in heart failure.

In addition to the contractile effects of urotensin, Onan et al. (84) recently demonstrated a strong hypertrophic growth effect of urotensin in neonatal cardiac myocytes when expression of the urotensin receptor was experimentally increased. Urotensin activates the ERK1/2 and p38 MAPK pathways through mechanisms involving the epidermal growth factor receptor (84). Urotensin induces proliferation of cultured VSMCs via phosphorylation of ERK1/2 (85). These studies (84,85) in cardiovascular cell types (cardiac myocytes, SMCs, and fibroblasts) confirm a previous finding that, in addition to its calcium mobilization effect characteristic of G protein receptor signaling, urotensin signaling caused activation of the ERK1/2 MAPK pathway in an experimental cell culture system (86).

### *Agonists and Antagonists of Urotensin*

Several agonists and antagonists of urotensin have been developed and will be helpful in understanding the function of urotensin in the cardiovascular system as well as in determining its potential usefulness as a therapeutic agent (79,87,88).

## MYOTROPHIN

Myotrophin was isolated from a crude homogenate generated from hearts of spontaneously hypertensive rats. The supernatant of this crude homogenate, distinguished from

the supernatant from healthy hearts, had the ability to stimulate cell growth in cultured rat neonatal cardiac myocytes. Fractionation, purification, and amino acid sequencing identified this factor as rat myotrophin, a 113 amino acid protein (89). Human myotrophin was cloned and is expressed in many tissues with relatively higher expression in the heart (90). In agreement with its initial identification as a hypertrophic factor in rat cultured cardiac myocytes, recombinant human myotrophin causes cardiac myocyte hypertrophy in cultured cells (90). Furthermore, the mRNA levels of myotrophin are elevated in human cardiomyopathic hearts compared with healthy hearts (90). Myotrophin mRNA and protein levels are increased by mechanical stretch in cultured cardiac myocytes, and mechanical stretch causes myotrophin to translocate from the cytoplasm to the nucleus and to form a complex with the activated transcription factor NF- $\kappa$ B, which can participate in the initiation of cardiac hypertrophy (91,92). The findings that myotrophin induced a hypertrophic response when added extracellularly and that mRNA and protein levels increased in response to mechanical stretch (hemodynamic stress) suggest that myotrophin acts in an autocrine/paracrine manner in cardiac myocyte hypertrophy.

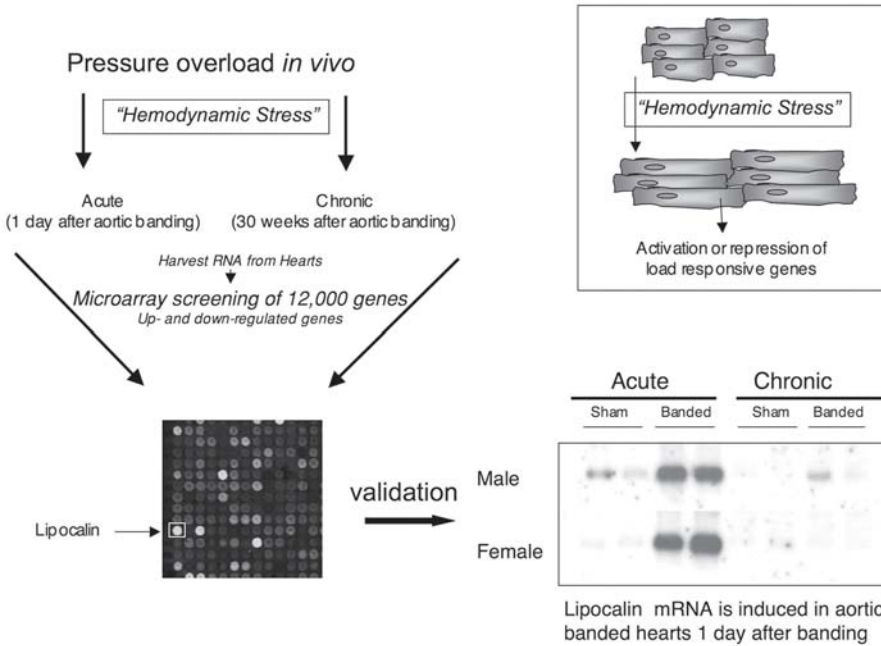
Transgenic mice overexpressing myotrophin in the heart have cardiac hypertrophy characterized by increased heart weight relative to body weight; increased myocyte cross-sectional area; and elevated mRNA levels of the hypertrophic marker genes, ANF, and  $\beta$ -myosin heavy chain. Cardiac hypertrophy in transgenic mice eventually progresses to heart failure (93), demonstrating that myotrophin is a causal factor in the development of hypertrophy and later transition to heart failure.

### *Myotrophin and Heart Failure*

O'Brien et al. (94) demonstrated that myotrophin is present in human plasma. This same study showed that plasma levels of myotrophin are increased in patients with heart failure. The elevation is greater in male patients with heart failure compared with female patients. Surprisingly, plasma myotrophin levels fall with increasing NYHA class. Levels of myotrophin appear to be independent of etiology of heart failure. As with other biomarkers, the cellular source of elevated myotrophin in heart failure is not known. Further studies are required to determine the usefulness of myotrophin as a biomarker for the diagnosis and prognosis of heart failure and as a biomarker for conditions of hemodynamic overload.

## NOVEL CANDIDATE MARKERS OF HEMODYNAMIC STRESS

To discover novel pathways induced in the heart in response to hemodynamic overload *in vivo*, we used DNA microarray technology to characterize on a genomewide scale the acute and long-term response of the heart to pressure overload (95). We used the well-established transverse aortic constriction model of pressure overload hypertrophy in mice in which an occluding clip is surgically placed around the transverse aorta to create a hemodynamic overload on the left ventricle. LV RNA was harvested from mice 1 d and 30 wk after the imposition of hemodynamic overload, which enabled characterization of the genomewide transcriptional response of the heart to acute hemodynamic overload (1 d after aortic banding) as well as that during compensation and adaptation to pressure overload (30 wk after aortic banding) (Fig. 8). Transverse aortic constriction resulted in a 40–50% increase in LV mass at 30 wk compared with LV mass in sham-operated mice, demonstrating significant LV hypertrophy. Aortic-banded hearts had preserved contractile function and a concentric pattern of remodeling, indicating compensatory hypertrophy and not failure.



**Fig. 8.** Demonstration of process by which a candidate biomarker is revealed through genomic screening of novel genes induced by hemodynamic overload in mice *in vivo*. Lipocalin is dramatically induced by acute hemodynamic overload of the heart. Validation by an independent technique is an important step following microarray results. Northern blotting validates DNA microarray findings for lipocalin. (Adapted from ref. 95.)

A striking initial observation in our study was that hemodynamic overload stimulated the transcription of genes unrelated to hemodynamic control, a concept that was raised at the beginning of this chapter. Functional classes of genes represented included transcription factors, signal transduction, protein processing/trafficking, protein synthesis and metabolism, immunity/inflammation, extracellular matrix, cytoskeleton, calcium binding, cobalt ion transport, apoptosis/cell death, growth inhibition, organogenesis, mRNA processing, as well as a significant number of nonannotated cDNAs of unknown functional class. Furthermore, we identified unique gene clusters that characterized acute vs chronic hemodynamic pressure overload. Thus, this study identified several previously unsuspected cardiac overload pathways to open the way for future investigation.

By identifying the secreted proteins encoded by the genes regulated by acute and chronic hemodynamic stress *in vivo*, novel candidate markers of hemodynamic stress may be identified. The gene most highly induced after acute hemodynamic overload was lipocalin (18-fold increased in male mice, 72-fold increased in female mice). Lipocalin is a small, secreted polypeptide that is protease resistant and has been detected in urine. Lipocalin was recently recognized as a urinary biomarker of acute renal failure owing to ischemic injury (96) as well as cisplatin nephrotoxicity (97). One function of lipocalin is to modify matrix metalloproteinase activity (98), which participates in cardiac remodeling following MI and in heart failure. Our finding of robust induction of lipocalin in the heart after acute hemodynamic stress suggests that it may be increased in the serum of patients following AMI.

Genes encoding secreted proteins that were induced by acute hemodynamic overload and further upregulated during chronic hemodynamic overload include thrombospon-

din-1 (sevenfold increased), osteoblast-specific factor 2 (sevenfold increased), biglycan (fourfold increased), and connective tissue growth factor (sixfold increased). Thrombospondin-1 is detected in the plasma of healthy individuals at low levels but can be increased when it is released from activated platelets. Many cell types other than platelets, including fibroblasts and ECs, express thrombospondin-1. Its secretion may therefore be induced in these cell types by hemodynamic stress. Thrombospondin-1 may be an inhibitor of angiogenesis through signaling cross talk with VEGF pathways. Single-nucleotide polymorphisms of thrombospondin-1 are significantly associated with familial premature CAD and MI (99). For a review on thrombospondin-1 *see ref. 100*.

Gene expression studies such as the one described here are limited in their ability to identify biomarkers, because gene expression in the heart often is not reflected by changes in a protein in the blood. Thus, new techniques in proteomics (*see Chapter 33*), which can separate and rapidly identify different proteins, have great promise for identifying novel biomarkers. Thus far, proteomics techniques have been difficult to apply to human blood, but as these techniques evolve, it is likely that new hemodynamic markers will emerge.

## CONCLUSION

The emergence of convincing evidence establishing BNP as a valuable diagnostic and prognostic marker in CVD has provided proof in principle for a clinical role for biomarkers of hemodynamic stress. ST2, an IL-1 receptor family member, is a novel biomarker of hemodynamic stress in AMI and heart failure. Additional novel hemodynamic markers that have been evaluated are adrenomedullin, urotensin, urocortin, and myotrophin; these proteins, in addition to being induced by hemodynamic stress, have hemodynamic effects in vascular beds and/or in the heart. Moreover, genomic strategies, such as we have described, have identified several novel candidate molecules that can be evaluated as biomarkers in future studies. With such efforts, it is likely that researchers will expand the set of hemodynamic biomarkers that may be useful for noninvasive characterization of underlying hemodynamic state, and short- and long-term prognosis.

## REFERENCES

1. Katz AM. Heart Failure: Pathophysiology, Molecular Biology, and Clinical Management, 1st ed. Lippincott Williams & Wilkins, Philadelphia, 2000.
2. Tominaga S. A putative protein of a growth specific cDNA from BALB/c-3T3 cells is highly similar to the extracellular portion of mouse interleukin 1 receptor. *FEBS Lett* 1989;258:301–304.
3. Kumar S, Minnich MD, Young PR. ST2/T1 protein functionally binds to two secreted proteins from Balb/c 3T3 and human umbilical vein endothelial cells but does not bind interleukin 1. *J Biol Chem* 1995;270:27,905–27,913.
4. Gayle MA, Slack JL, Bonnert TP, et al. Cloning of a putative ligand for the T1/ST2 receptor. *J Biol Chem* 1996;271:5784–5789.
5. O'Neill LA. Signal transduction pathways activated by the IL-1 receptor/toll-like receptor superfamily. *Curr Top Microbiol Immunol* 2002;270:47–61.
6. Sweet MJ, Leung BP, Kang D, et al. A novel pathway regulating lipopolysaccharide-induced shock by ST2/T1 via inhibition of Toll-like receptor 4 expression. *J Immunol* 2001;166:6633–6639.
7. Brint EK, Xu D, Liu H, et al. ST2 is an inhibitor of interleukin 1 receptor and Toll-like receptor 4 signaling and maintains endotoxin tolerance. *Nat Immunol* 2004;5:373–379.
8. Leung BP, Xu D, Culshaw S, McInnes IB, Liew FY. A novel therapy of murine collagen-induced arthritis with soluble T1/ST2. *J Immunol* 2004;173:145–150.
9. Yanagisawa K, Takagi T, Tsukamoto T, Tetsuka T, Tominaga S. Presence of a novel primary response gene ST2L, encoding a product highly similar to the interleukin 1 receptor type 1. *FEBS Lett* 1993;318: 83–87.

10. Lohning M, Stroehmann A, Coyle AJ, et al. T1/ST2 is preferentially expressed on murine Th2 cells, independent of interleukin 4, interleukin 5, and interleukin 10, and important for Th2 effector function. *Proc Natl Acad Sci USA* 1998;95:6930–6935.
11. Townsend MJ, Fallon PG, Matthews DJ, Jolin HE, McKenzie AN. T1/ST2-deficient mice demonstrate the importance of T1/ST2 in developing primary T helper cell type 2 responses. *J Exp Med* 2000;191:1069–1076.
12. Xu D, Chan WL, Leung BP, et al. Selective expression of a stable cell surface molecule on type 2 but not type 1 helper T cells. *J Exp Med* 1998;187:787–794.
13. Coyle AJ, Lloyd C, Tian J, et al. Crucial role of the interleukin 1 receptor family member T1/ST2 in T helper cell type 2-mediated lung mucosal immune responses. *J Exp Med* 1999;190:895–902.
14. Sadoshima J, Xu Y, Slayter HS, Izumo S. Autocrine release of angiotensin II mediates stretch-induced hypertrophy of cardiac myocytes in vitro. *Cell* 1993;75:977–984.
15. Weinberg EO, Shimpo M, De Keulenaer GW, et al. Expression and regulation of ST2, an interleukin-1 receptor family member, in cardiomyocytes and myocardial infarction. *Circulation* 2002;106:2961–2966.
16. Kuroiwa K, Li H, Tago K, et al. Construction of ELISA system to quantify human ST2 protein in sera of patients. *Hybridoma* 2000;19:151–159.
17. Pfeffer MA, Greaves SC, Arnold JM, et al. Early versus delayed angiotensin-converting enzyme inhibition therapy in acute myocardial infarction: the healing and early afterload reducing therapy trial. *Circulation* 1997;95:2643–2651.
18. Solomon SD, Glynn RJ, Greaves S, et al. Recovery of ventricular function after myocardial infarction in the reperfusion era: the healing and early afterload reducing therapy study. *Ann Intern Med* 2001;134:451–458.
19. Aikawa Y, Rohde L, Plehn J, et al. Regional wall stress predicts ventricular remodeling after antero-septal myocardial infarction in the Healing and Early Afterload Reducing Trial (HEART): an echocardiography-based structural analysis. *Am Heart J* 2001;141:234–242.
20. Shimpo M, Morrow DA, Weinberg EO, et al. Serum levels of the interleukin-1 receptor family member ST2 predict mortality and clinical outcome in acute myocardial infarction. *Circulation* 2004;109:2186–2190.
21. Antman EM, Giugliano RP, Gibson CM, et al. Abciximab facilitates the rate and extent of thrombolysis: results of the Thrombolysis in Myocardial Infarction (TIMI) 14 trial. The TIMI 14 Investigators. *Circulation* 1999;99:2720–2732.
22. Antman EM, Gibson CM, de Lemos JA, et al. Combination reperfusion therapy with abciximab and reduced dose reteplase: results from TIMI 14. The Thrombolysis in Myocardial Infarction (TIMI) 14 Investigators. *Eur Heart J* 2000;21:1944–1953.
23. Antman EM, Louwerenburg HW, Baars HF, et al. Enoxaparin as adjunctive antithrombin therapy for ST-elevation myocardial infarction: results of the ENTIRE-Thrombolysis in Myocardial Infarction (TIMI) 23 Trial. *Circulation* 2002;105:1642–1649.
24. Weinberg EO, Shimpo M, Hurwitz S, Tominaga S, Rouleau JL, Lee RT. Identification of serum soluble ST2 receptor as a novel heart failure biomarker. *Circulation* 2003;107:721–726.
25. Eto T, Kato J, Kitamura K. Regulation of production and secretion of adrenomedullin in the cardiovascular system. *Regul Pept* 2003;112:61–69.
26. Dumont Y, Chabot JG, Quirion R. Receptor autoradiography as mean to explore the possible functional relevance of neuropeptides: focus on new agonists and antagonists to study natriuretic peptides, neuropeptide Y and calcitonin gene-related peptides. *Peptides* 2004;25:365–391.
27. Isumi Y, Minamino N, Katafuchi T, et al. Adrenomedullin production in fibroblasts: its possible function as a growth regulator of Swiss 3T3 cells. *Endocrinology* 1998;139:2552–2563.
28. Tomoda Y, Kikumoto K, Isumi Y, et al. Cardiac fibroblasts are major production and target cells of adrenomedullin in the heart in vitro. *Cardiovasc Res* 2001;49:721–730.
29. Shinoki N, Kawasaki T, Minamino N, et al. Shear stress down-regulates gene transcription and production of adrenomedullin in human aortic endothelial cells. *J Cell Biochem* 1998;71:109–115.
30. Chun TH, Itoh H, Ogawa Y, et al. Shear stress augments expression of C-type natriuretic peptide and adrenomedullin. *Hypertension* 1997;29:1296–1302.
31. Tsuruda T, Kato J, Kitamura K, et al. Enhanced adrenomedullin production by mechanical stretching in cultured rat cardiomyocytes. *Hypertension* 2000;35:1210–1214.
32. Isumi Y, Shoji H, Sugo S, et al. Regulation of adrenomedullin production in rat endothelial cells. *Endocrinology* 1998;139:838–846.

33. Shichiri M, Fukai N, Ozawa N, Iwasaki H, Hirata Y. Adrenomedullin is an autocrine/paracrine growth factor for rat vascular smooth muscle cells. *Regul Pept* 2003;112:167–173.
34. De Matteo R, May CN. Direct coronary vasodilator action of adrenomedullin is mediated by nitric oxide. *Br J Pharmacol* 2003;140:1414–1420.
35. Miyao Y, Nishikimi T, Goto Y, et al. Increased plasma adrenomedullin levels in patients with acute myocardial infarction in proportion to the clinical severity. *Heart* 1998;79:39–44.
36. Nagaya N, Nishikimi T, Uematsu M, et al. Plasma adrenomedullin as an indicator of prognosis after acute myocardial infarction. *Heart* 1999;81:483–487.
37. Richards AM, Nicholls MG, Yandle TG, et al. Plasma N-terminal pro-brain natriuretic peptide and adrenomedullin: new neurohormonal predictors of left ventricular function and prognosis after myocardial infarction. *Circulation* 1998;97:1921–1929.
38. Nishikimi T, Saito Y, Kitamura K, et al. Increased plasma levels of adrenomedullin in patients with heart failure. *J Am Coll Cardiol* 1995;26:1424–1431.
39. Ishimitsu T, Nishikimi T, Saito Y, et al. Plasma levels of adrenomedullin, a newly identified hypotensive peptide, in patients with hypertension and renal failure. *J Clin Invest* 1994;94:2158–2161.
40. Jougasaki M, Rodeheffer RJ, Redfield MM, et al. Cardiac secretion of adrenomedullin in human heart failure. *J Clin Invest* 1996;97:2370–2376.
41. Kobayashi K, Kitamura K, Etoh T, et al. Increased plasma adrenomedullin levels in chronic congestive heart failure. *Am Heart J* 1996;131:994–998.
42. Pousset F, Masson F, Chavirovskaia O, et al. Plasma adrenomedullin, a new independent predictor of prognosis in patients with chronic heart failure. *Eur Heart J* 2000;21:1009–1014.
43. Richards AM, Doughty R, Nicholls MG, et al. Plasma N-terminal pro-brain natriuretic peptide and adrenomedullin: prognostic utility and prediction of benefit from carvedilol in chronic ischemic left ventricular dysfunction. Australia-New Zealand Heart Failure Group. *J Am Coll Cardiol* 2001;37:1781–1787.
44. Nagaya N, Satoh T, Nishikimi T, et al. Hemodynamic, renal, and hormonal effects of adrenomedullin infusion in patients with congestive heart failure. *Circulation* 2000;101:498–503.
45. Vaughan J, Donaldson C, Bittencourt J, et al. Urocortin, a mammalian neuropeptide related to fish uroresin I and to corticotropin-releasing factor. *Nature* 1995;378:287–292.
46. Parkes DG, Weisinger RS, May CN. Cardiovascular actions of CRH and urocortin: an update. *Peptides* 2001;22:821–827.
47. Latchman DS. Urocortin. *Int J Biochem Cell Biol* 2002;34:907–910.
48. Coste SC, Quintos RF, Stenzel-Poore MP. Corticotropin-releasing hormone-related peptides and receptors: emergent regulators of cardiovascular adaptations to stress. *Trends Cardiovasc Med* 2002;12:176–182.
49. Parkes DG, Vaughan J, Rivier J, Vale W, May CN. Cardiac inotropic actions of urocortin in conscious sheep. *Am J Physiol* 1997;272:H2115–H2122.
50. Davis ME, Pemberton CJ, Yandle TG, et al. Urocortin-1 infusion in normal humans. *J Clin Endocrinol Metab* 2004;89:1402–1409.
51. Okosi A, Brar BK, Chan M, et al. Expression and protective effects of urocortin in cardiac myocytes. *Neuropeptides* 1998;32:167–171.
52. Nishikimi T, Miyata A, Horio T, et al. Urocortin, a member of the corticotropin-releasing factor family, in normal and diseased heart. *Am J Physiol Heart Circ Physiol* 2000;279:H3031–H3039.
53. Ikeda K, Tojo K, Sato S, et al. Urocortin, a newly identified corticotropin-releasing factor-related mammalian peptide, stimulates atrial natriuretic peptide and brain natriuretic peptide secretions from neonatal rat cardiomyocytes. *Biochem Biophys Res Commun* 1998;250:298–304.
54. Ikeda K, Tojo K, Oki Y, Nakao K. Urocortin has cell-proliferative effects on cardiac non-myocytes. *Life Sci* 2002;71:1929–1938.
55. Ikeda K, Tojo K, Tokudome G, et al. Cardiac expression of urocortin (Ucn) in diseased heart: preliminary results on possible involvement of Ucn in pathophysiology of cardiac diseases. *Mol Cell Biochem* 2003;252:25–32.
56. Kimura Y, Takahashi K, Totsune K, et al. Expression of urocortin and corticotropin-releasing factor receptor subtypes in the human heart. *J Clin Endocrinol Metab* 2002;87:340–346.
57. Takahashi K, Totsune K, Murakami O, et al. Expression of urocortin III/stresscopin in human heart and kidney. *J Clin Endocrinol Metab* 2004;89:1897–1903.
58. Rademaker MT, Charles CJ, Espiner EA, et al. Beneficial hemodynamic, endocrine, and renal effects of urocortin in experimental heart failure: comparison with normal sheep. *J Am Coll Cardiol* 2002;40:1495–1505.



59. Bale TL, Hoshijima M, Gu Y, et al. The cardiovascular physiologic actions of urocortin II: acute effects in murine heart failure. *Proc Natl Acad Sci USA* 2004;101:3697–3702.
60. Ng LL, Loke IW, O'Brien RJ, Squire IB, Davies JE. Plasma urocortin in human systolic heart failure. *Clin Sci (Lond)* 2004;106:383–388.
61. Bale TL, Giordano FJ, Hickey RP, et al. Corticotropin-releasing factor receptor 2 is a tonic suppressor of vascularization. *Proc Natl Acad Sci USA* 2002;99:7734–7739.
62. Brar BK, Jonassen AK, Egorina EM, et al. Urocortin-II and urocortin-III are cardioprotective against ischemia reperfusion injury: an essential endogenous cardioprotective role for corticotropin releasing factor receptor type 2 in the murine heart. *Endocrinology* 2004;145:24–35; discussion 21–23.
63. Schulman D, Latchman DS, Yellon DM. Urocortin protects the heart from reperfusion injury via up-regulation of p42/p44 MAPK signaling pathway. *Am J Physiol Heart Circ Physiol* 2002;283:H1481–H1488.
64. Agnello D, Bertini R, Sacco S, Meazza C, Villa P, Ghezzi P. Corticosteroid-independent inhibition of tumor necrosis factor production by the neuropeptide urocortin. *Am J Physiol* 1998;275:E757–E762.
65. Janjua S, Lawrence KM, Ng LL, Latchman DS. The cardioprotective agent urocortin induces expression of CT-1. *Cardiovasc Toxicol* 2003;3:255–262.
66. Reis FM, Luisi S, Florio P, Degrassi A, Petraglia F. Corticotropin-releasing factor, urocortin and endothelin-1 stimulate activin A release from cultured human placental cells. *Placenta* 2002;23:522–525.
67. Yndestad A, Ueland T, Oie E, et al. Elevated levels of activin A in heart failure: potential role in myocardial remodeling. *Circulation* 2004;109:1379–1385.
68. Ames RS, Sarau HM, Chambers JK, et al. Human urotensin-II is a potent vasoconstrictor and agonist for the orphan receptor GPR14. *Nature* 1999;401:282–286.
69. Maguire JJ, Kuc RE, Davenport AP. Orphan-receptor ligand human urotensin II: receptor localization in human tissues and comparison of vasoconstrictor responses with endothelin-1. *Br J Pharmacol* 2000;131:441–446.
70. Matsushita M, Shichiri M, Imai T, et al. Co-expression of urotensin II and its receptor (GPR14) in human cardiovascular and renal tissues. *J Hypertens* 2001;19:2185–2190.
71. Cheung BM, Leung R, Man YB, Wong LY. Plasma concentration of urotensin II is raised in hypertension. *J Hypertens* 2004;22:1341–1344.
72. Tzanidis A, Hannan RD, Thomas WG, et al. Direct actions of urotensin II on the heart: implications for cardiac fibrosis and hypertrophy. *Circ Res* 2003;93:246–253.
73. Douglas SA, Tayara L, Ohlstein EH, Halawa N, Giaid A. Congestive heart failure and expression of myocardial urotensin II. *Lancet* 2002;359:1990–1997.
74. Richards AM, Nicholls MG, Lainchbury JG, Fisher S, Yandle TG. Plasma urotensin II in heart failure. *Lancet* 2002;360:545–546.
75. Lapp H, Boerrigter G, Costello-Boerrigter LC, et al. Elevated plasma human urotensin-II-like immunoreactivity in ischemic cardiomyopathy. *Int J Cardiol* 2004;94:93–97.
76. Russell FD, Meyers D, Galbraith AJ, et al. Elevated plasma levels of human urotensin-II immunoreactivity in congestive heart failure. *Am J Physiol Heart Circ Physiol* 2003;285:H1576–H1581.
77. Heringlake M, Kox T, Uzun O, et al. The relationship between urotensin II plasma immunoreactivity and left ventricular filling pressures in coronary artery disease. *Regul Pept* 2004;121:129–136.
78. Ng LL, Loke I, O'Brien RJ, Squire IB, Davies JE. Plasma urotensin in human systolic heart failure. *Circulation* 2002;106:2877–2880.
79. Douglas SA, Dhanak D, Johns DG. From 'gills to pills': urotensin-II as a regulator of mammalian cardiorenal function. *Trends Pharmacol Sci* 2004;25:76–85.
80. Hassan GS, Chouiali F, Saito T, et al. Effect of human urotensin-II infusion on hemodynamics and cardiac function. *Can J Physiol Pharmacol* 2003;81:125–128.
81. Affolter JT, Newby DE, Wilkinson IB, Winter MJ, Balment RJ, Webb DJ. No effect on central or peripheral blood pressure of systemic urotensin II infusion in humans. *Br J Clin Pharmacol* 2002;54:617–621.
82. Bohm F, Pernow J. Urotensin II evokes potent vasoconstriction in humans in vivo. *Br J Pharmacol* 2002;135:25–27.
83. Lim M, Honisett S, Sparkes CD, Komesaroff P, Kompa A, Krum H. Differential effect of urotensin II on vascular tone in normal subjects and patients with chronic heart failure. *Circulation* 2004;109:1212–1214.
84. Onan D, Pipolo L, Yang E, Hannan RD, Thomas WG. Urotensin-II promotes hypertrophy of cardiac myocytes via mitogen-activated protein kinases. *Mol Endocrinol* 2004;18:2344–2354.

85. Tamura K, Okazaki M, Tamura M, Isozumi K, Tasaki H, Nakashima Y. Urotensin II-induced activation of extracellular signal-regulated kinase in cultured vascular smooth muscle cells: involvement of cell adhesion-mediated integrin signaling. *Life Sci* 2003;72:1049–1060.
86. Ziltener P, Mueller C, Haenig B, Scherz MW, Nayler O. Urotensin II mediates ERK1/2 phosphorylation and proliferation in GPR14-transfected cell lines. *J Recept Signal Transduct Res* 2002;22:155–168.
87. Carotenuto A, Grieco P, Novellino E, Rovero P. Urotensin-II receptor peptide agonists. *Med Res Rev* 2004;24:577–588.
88. Behm DJ, Herold CL, Camarda V, Aiyar NV, Douglas SA. Differential agonistic and antagonistic effects of the urotensin-II ligand SB-710411 at rodent and primate UT receptors. *Eur J Pharmacol* 2004;492:113–116.
89. Sen S, Kundu G, Mekhail N, Castel J, Misono K, Healy B. Myotrophin: purification of a novel peptide from spontaneously hypertensive rat heart that influences myocardial growth. *J Biol Chem* 1990;265:16,635–16,643.
90. Anderson KM, Berrebi-Bertrand I, Kirkpatrick RB, et al. cDNA sequence and characterization of the gene that encodes human myotrophin/V-1 protein, a mediator of cardiac hypertrophy. *J Mol Cell Cardiol* 1999;31:705–719.
91. Gupta S, Sen S. Myotrophin-kappaB DNA interaction in the initiation process of cardiac hypertrophy. *Biochim Biophys Acta* 2002;1589:247–260.
92. Knuefermann P, Chen P, Misra A, Shi SP, Abdellatif M, Sivasubramanian N. Myotrophin/V-1, a protein up-regulated in the failing human heart and in postnatal cerebellum, converts NFkappa B p50-p65 heterodimers to p50-p50 and p65-p65 homodimers. *J Biol Chem* 2002;277:23,888–23,897.
93. Sarkar S, Leaman DW, Gupta S, et al. Cardiac overexpression of myotrophin triggers myocardial hypertrophy and heart failure in transgenic mice. *J Biol Chem* 2004;279:20,422–20,434.
94. O'Brien RJ, Loke I, Davies JE, Squire IB, Ng LL. Myotrophin in human heart failure. *J Am Coll Cardiol* 2003;42:719–725.
95. Weinberg EO, Mirotsoy M, Gannon J, Dzau VJ, Lee RT, Pratt RE. Sex dependence and temporal dependence of the left ventricular genomic response to pressure overload. *Physiol Genomics* 2003;12:113–127.
96. Mishra J, Ma Q, Prada A, et al. Identification of neutrophil gelatinase-associated lipocalin as a novel early urinary biomarker for ischemic renal injury. *J Am Soc Nephrol* 2003;14:2534–2543.
97. Mishra J, Mori K, Ma Q, Kelly C, Barasch J, Devarajan P. Neutrophil gelatinase-associated lipocalin: a novel early urinary biomarker for cisplatin nephrotoxicity. *Am J Nephrol* 2004;24:307–315.
98. Yan L, Borregaard N, Kjeldsen L, Moses MA. The high molecular weight urinary matrix metalloproteinase (MMP) activity is a complex of gelatinase B/MMP-9 and neutrophil gelatinase-associated lipocalin (NGAL). Modulation of MMP-9 activity by NGAL. *J Biol Chem* 2001;276:37,258–37,265.
99. Stenina OI, Byzova TV, Adams JC, McCarthy JJ, Topol EJ, Plow EF. Coronary artery disease and the thrombospondin single nucleotide polymorphisms. *Int J Biochem Cell Biol* 2004;36:1013–1030.
100. Adams JC, Lawler J. The thrombospondins. *Int J Biochem Cell Biol* 2004;36:961–968.



# V

---

## BIOMARKERS OF PLATELET FUNCTION AND HEMOSTASIS

---



# 26

---

## Clinical and Research Applications of Markers of Thrombosis

---

*Manesh R. Patel, MD*  
*and Richard C. Becker, MD*

### CONTENTS

INTRODUCTION  
INITIATION OF THROMBOSIS  
PLATELET DEPOSITION AND ACTIVATION  
ACTIVATION OF COAGULATION FACTORS AND THROMBIN GENERATION  
ANTICOAGULANT PATHWAYS IN MAINTAINING HEMOSTASIS  
MARKERS OF THROMBOSIS  
ANTICOAGULATION SYSTEM BIOMARKERS  
PLATELET SURFACE MARKERS  
EC MARKERS  
CURRENT LIMITATIONS  
CONCLUSION  
REFERENCES

---

### SUMMARY

We provide a brief overview of vascular thrombosis as applied to the arterial circulatory system. This background serves as a template for understanding potential biomarkers of thrombosis. Additionally, the integrated relationship between genotype and phenotypic expression of disease, measurable as circulating (soluble) proteins and cell-based products, including fibrinogen, thrombin, thrombomodulin, tissue factor, tissue factor pathway inhibitor, platelet surface markers, and others, is highlighted. Finally, the role of endothelial cell and endothelial cell-surface markers as biomarkers of thrombosis is discussed. As applicable, the clinical and potential research applications of specific biomarkers of thrombosis are provided.

**Key Words:** Thrombosis; biomarker; coagulation; endothelial cell.

From: *Contemporary Cardiology:  
Cardiovascular Biomarkers: Pathophysiology and Disease Management*  
Edited by: David A. Morrow © Humana Press Inc., Totowa, NJ

## INTRODUCTION

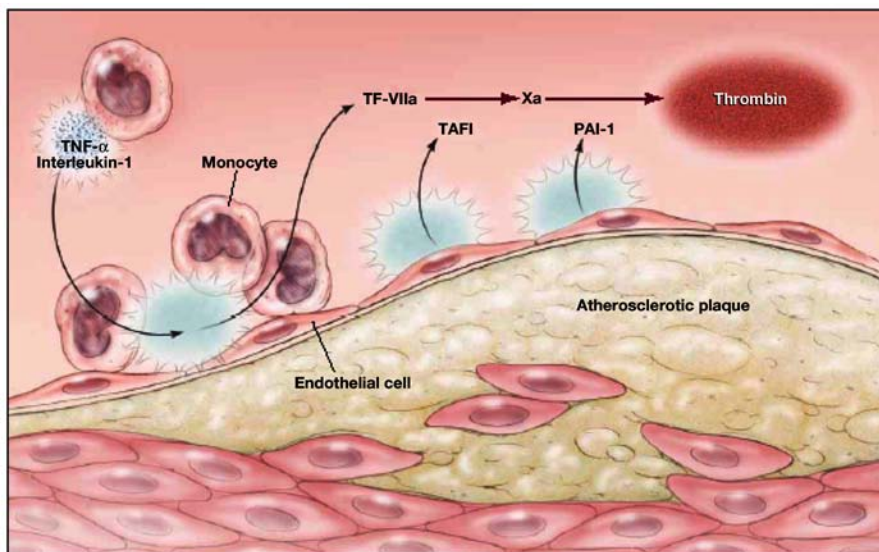
Hemostasis is the physiological process that maintains blood in a fluid state within circulation (2). Under normal physiological circumstances, blood components do not interact with an intact vascular endothelium. Arterial thrombosis, like venous thrombosis, as described by Virchow, occurs when there is alteration in blood flow, change in the hemostatic protein composition of blood, or change in the vessel wall. The activation of coagulation leads to a series of cell-surface-based events that result in the activation of multiple proteins. These proteins not only function to increase the clotting ability of blood, but they simultaneously activate anticoagulant processes as well. In this manner, the exquisite balance of hemostasis is restored with both thrombin and fibrin generation and degradation all occurring at any given moment.

Thrombosis within the coronary vascular bed is a dynamic process, with clot formation and dissolution occurring simultaneously at many sites. Occlusive thrombus and circulatory compromise occur when there is a shift in the balance between these processes (1). Recent advances in understanding the pathobiology of atherothrombosis have demonstrated a finely orchestrated interplay among inflammation, thrombosis, and oxidative stress. As the fundamental properties of atherogenesis, endothelial cell injury/dysfunction, plaque metamorphosis, and thrombogenesis are elucidated, measurable biological markers representing the natural history of disease that can be used for diagnosis, risk assessment, and the management of patients with coronary atherothrombosis are likely to emerge.

## INITIATION OF THROMBOSIS

The initiation of thrombosis is dependent on two critical steps: vessel wall injury and the adherence of platelets on this disrupted surface. When there is a dysfunctional surface or a breach in the endothelial surface, a series of biochemical events is triggered that leads to the rapid deposition of platelets and insoluble fibrin as an initial plug that is the start of the repair process. In a cell-based model of arterial thrombosis, the integrity and state of the endothelium are the basis for the initiation of thrombosis (3). The pivotal step in transforming the endothelium into a procoagulant surface is the production of tissue factor (4,5) (Fig. 1). Tissue factor is an integral membrane glycoprotein that must be anchored to a phospholipid membrane to be active (6). Activated monocytes, attracted to sites of vascular injury by tumor necrosis factor (TNF)- $\alpha$  and interleukin-1, also elaborate tissue factor (7,8). Tissue factor forms a complex with factor VII and activated factor VII (VIIa), a powerful procoagulant complex that cleaves its substrates, factor IX and factor X, and starts the coagulation cascade (6,9).

In addition to elaborating tissue factor when activated, the endothelium participates in the second component of thrombus initiation—platelet deposition. The primary molecule responsible for platelet adhesion is von Willebrand factor (vWF), especially in vessels with high shear stress such as coronary vessels (10,11). This molecule is synthesized by the endothelium. Activated or injured endothelial cells (ECs) can also release vWF and P-selectin, molecules also involved in platelet and leukocyte adhesion (12). Storage granules, called Weibel-Palade bodies, contain P-selectin and vWF within the EC and fuse with the cell membrane on activation to present these molecules on the EC surface (13,14). In this manner, through either activation or severe injury leading to deendothelialization, the molecular signals for both the initiation of coagulation and platelet adhesion are initiated at the vessel wall.



**Fig. 1.** Cell-based model of arterial thrombosis. Monocyte-derived tissue factor is provoked by inflammatory cytokines and contributes to thrombin generation in atherothrombotic CAD, a prothrombotic disorder characterized by endothelial dysfunction. Impaired thromboresistance and attenuated fibrinolytic potential TF, tissue factor; VIIa, factor VIIa; Xa, factor Xa; TAFI, thrombin-activated fibrinolytic inhibitor. (Adapted from ref. [112](#).)

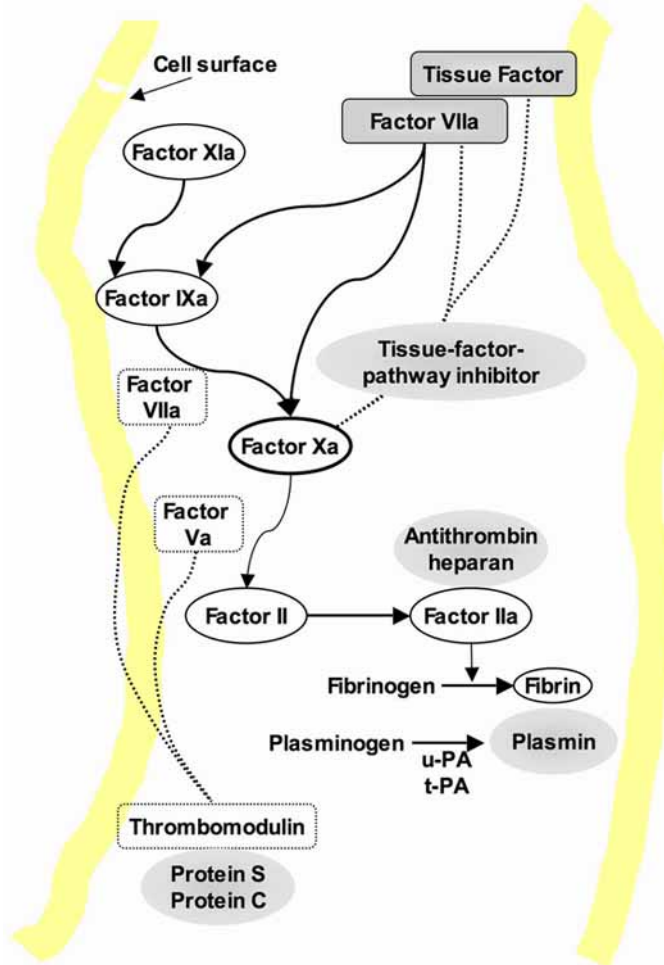
## PLATELET DEPOSITION AND ACTIVATION

Platelets play a central role in arterial thrombosis. Platelets adhere, activate, aggregate, and promote thrombus formation. As mentioned, platelets adhere to activated or denuded endothelial surfaces via bonds between vWF and P-selectin. The platelet membrane receptor glycoprotein Ib-IX (GpIb-IX) binds vWF ([15](#)). This bond tethers platelets to the surface, initiating adherence and subsequent aggregation. Platelets also bind exposed collagen, stabilizing the platelet plug and provoking the expression of GpIIb/IIIa and the release of adenosine 5'-diphosphate and thromboxane A<sub>2</sub>. These molecules act in an autocrine manner and lead to an amplification of platelet aggregation. Fibrinogen rapidly binds the GpIIb/IIIa receptors and crosslinks the platelet plug simultaneously as thrombin and fibrin are produced by the coagulation cascade. Once thrombin is generated, it serves to further activate platelets ([16](#)).

## ACTIVATION OF COAGULATION FACTORS AND THROMBIN GENERATION

As platelet adherence and activation are occurring, tissue factor forms a complex with factor VII and activated factor VIIa that cleaves both factors IX and X. Additionally, factor IX, activated by tissue factor, activates additional factor X, a reaction in which factor VIII serves as a cofactor. Factor Xa along with cofactor Va activates prothrombin (factor II) to thrombin (factor IIa). The production of thrombin precipitates fibrin formation, the final process of coagulation. Thrombin converts fibrinogen into fibrin monomers. Thrombin also activates platelets, converts factor V into Va, factor XI into XIa, and factor VIII into VIIIa (after VIII dissociates from vWF). The fibrin monomers polymerize to form fibrin strands that in turn terminate the factor XIII-mediated crosslinking to form a “mature” fibrin network ([Fig. 2](#)).





**Fig. 2.** A cell-based model of coagulation is initiated on tissue factor bearing cells, followed by assembly of clotting proteins on a template of activated (and aggregated) platelets that leads to thrombin (factor IIa) generation. Vascular thromboresistance, governed by antithrombin III, protein C, and TFPI, attenuates thrombin development, as does plasmin generated by tPA and uPA. This system of checks and balances is vital for maintaining vascular integrity and tissue-level hemostasis. (From ref. 2.)

## ANTICOAGULANT PATHWAYS IN MAINTAINING HEMOSTASIS

Coagulation is a rapid and potentially explosive process with several points of amplification. Four intrinsic systems are in place to modulate hemostasis and provide anticoagulant mechanistic control (thromboresistance). Tissue factor pathway inhibitor (TFPI) is a potent protease inhibitor that is synthesized within ECs (17). TFPI binds to and inactivates factor Xa. The TFPI-Xa complex then binds to tissue factor-VIIa complex and forms a quaternary structure that prevents further activation. Antithrombin is also a potent protease inhibitor that participates in vascular surface thromboresistance. It binds thrombin and forms an irreversible complex (18). In the presence of endogenous or exogenous heparin, antithrombin undergoes a conformational change that leads to a 1000-fold increase in affinity for thrombin (19).

Thrombin generation is further limited by thrombomodulin (20). Thrombomodulin is a membrane protein on the surface of the EC. Binding of thrombomodulin to thrombin leads to a structural change that prevents the ability to activate fibrin and further confers a binding site for protein C. Once protein C is activated by the thrombin–thrombomodulin complex, it combines with protein S on phospholipid membranes to inactivate factors Va and VIIIa (21).

Finally, endogenous fibrinolysis attenuates fibrin clot propagation and also participates in vascular repair. Circulating plasminogen binds to the fibrin clot and is converted into plasmin by EC-released tissue-type plasminogen activator (tPA) (22). Urokinase plasminogen activator (uPA) is the major source of plasminogen activator in the extravascular space. Plasmin cleaves fibrin at multiple sites and releases fibrin degradation products (FDPs). FDPs containing two D-domains of two fibrin monomers crosslinked with factor VIII are referred to as D-dimers. The plasminogen system is also under complex control (23). One of the major regulating molecules is plasminogen activator inhibitor-1 (PAI-1). PAI-1 is produced in ECs and platelets and regulates the extent of fibrinolysis (23).

To achieve hemostasis continually, a complex series of reactions that balance both coagulation and anticoagulation must occur. A slight shift in the balance of this delicate process can lead either to rapid amplification of signals and circulatory compromise from obstructive thrombus or to uncontrolled bleeding. The next section discusses the clinical relevance of the traditional markers of thrombosis and the genotype–phenotype relationship of these markers.

## MARKERS OF THROMBOSIS

Proteases involved in the coagulation cascade and its regulation, as well as molecules involved in endogenous fibrinolysis, are potential candidate biomarkers of thrombosis (Table 1). To be considered clinically useful, a biomarker must be readily measurable, and it must be shown in prospective clinical studies to provide diagnostic or prognostic information. Finally, prospective studies with therapeutic agents that alter the measurable biomarker levels and correlate with clinical outcomes would complete the cycle of clinical utility.

Presently there are no biomarkers of thrombosis that completely satisfy these criteria. Challenges to meeting all of these criteria include the redundant nature of the coagulation and anticoagulation process, contributing environmental factors, and patient-specific variability (2,24). Accordingly, in order to determine biological markers of thrombosis applicable to the coronary arterial circulation, studies targeting specific populations with known environmental risk factors for thrombosis are required.

### *Fibrinogen*

Fibrinogen is a coagulation protein that has been investigated extensively as a potential predictor of cardiovascular thrombosis among patients with and without prior cardiac disease. Fibrinogen is a large plasma protein produced in the normal human liver. The protein contains two identical subunits made up of three polypeptide chains,  $\alpha$ ,  $\beta$ , and  $\gamma$ , linked together with disulfide bonds. The final protein is cleaved by thrombin into fibrin monomers that subsequently polymerize to form fibrin strands, stabilizing the meshwork within the developing thrombus.

Although several genetic polymorphisms have been identified, the association with phenotypic changes in the fibrinogen molecule and disease is inconsistent (24). Additionally,

Table 1  
Biomarkers of Thrombosis

<i>Biomarkers</i>	<i>Prospective studies</i>	<i>Ability to measure</i>	<i>Specific populations</i>	<i>Venous or arterial thrombosis</i>	<i>Clinical utility</i>
Fibrinogen	++++	++	Women, smokers	Arterial	++
Thrombin	++	+/-	Women, smokers	Arterial/	+
Thrombomodulin	++	+	African Americans, smokers	venous	
PAI-1	+++	+	Men, insulin resistance, high-triglyceride populations	Arterial	+/-
tPA activator	++	+	Men	Arterial	+/-
<i>Platelet markers</i>					
GpIIb/IIIa receptors	+	-	ACS	Arterial	-
CD40L	++	+	ACS populations treated with GpIIb/IIIa antagonists	Arterial	++
P-selectin	+	+	AMI	Arterial	+
<i>Endothelial markers</i>					
vWF	++	+	ACS	Arterial	+/-
E-selectin	+	+	AMI	Arterial	+/-

the phenotypic expression of fibrinogen varies with populations and environmental factors. Notably, women have higher fibrinogen levels compared with men, and smoking tobacco increases fibrinogen levels (25,26).

Prospective studies in patients without cardiovascular disease (CVD) have demonstrated the independent predictive value of fibrinogen measurement for future events (27–34). The two largest studies investigating fibrinogen as a prognostic biomarker are the Physicians' Health Study and the Prospective Epidemiological Study of Myocardial Infarction (PRIME) (27,28). In the Physicians' Health Study, including more than 14,000 patients, fibrinogen levels independently predicted myocardial infarction (MI) after controlling for traditional cardiac risk factors (27). The PRIME study evaluated more than 10,000 male patients. After adjusting for cardiovascular risk factors, fibrinogen levels were associated with CVD. The odds ratio (OR) was 1.31 for each standard deviation increase in the fibrinogen level above the normal value.

Fibrinogen levels have also been correlated with cardiovascular events in patients with coronary heart disease (CHD) (35–38). The European Concerted Action on Thrombosis and Disabilities Angina Pectoris Study prospectively evaluated 3043 patients with angina pectoris and baseline angiography. After controlling for extent of coronary disease and cardiovascular risk factors, baseline fibrinogen predicted future MI and sudden death (35). Additionally, low fibrinogen levels in the patients with high cholesterol levels identified a low-risk patient group. In the Bezafibrate Coronary Atherosclerosis Intervention Trial, evaluating the effect of bezafibrate in young male survivors of MI, fibrinogen levels independently predicted cardiovascular mortality. In a subgroup of patients undergoing angiography, bezafibrate reduced the fibrinogen levels and led to a reduction in coronary stenosis on angiography (36,39).

These data in total represent significant prospective epidemiological evidence for the ability of fibrinogen to predict future cardiovascular events in patients with and without CVD (40). There is additional evidence that fibrinogen levels may also add prognostic information above lipid measurements. Finally, pilot evidence demonstrates that when fibrinogen levels are modified, there is a reduction in the risk of cardiovascular morbidity and mortality. Continued research aimed at determining the prognostic value of fibrinogen when used alongside traditional tools for cardiovascular risk assessment, such as the Framingham risk score, and other biomarkers, such as high-sensitivity C-reactive protein, is required to solidify the clinical utility of fibrinogen as a meaningful biomarker in routine clinical practice.

### ***Thrombin***

Thrombin is a pivotal enzyme in both protective hemostasis and pathological thrombosis with several discrete functions that include platelet activation; EC activation; monocyte tissue factor expression; conversion of fibrinogen into fibrin; activation of factors V, VIII, and XIII; and, finally, binding to the regulatory molecules antithrombin and thrombomodulin.

The most widely studied genetic mutation of thrombin production is the prothrombin 20210G/A polymorphism. Although clearly linked to venous thromboembolic disease, this particular prothrombin polymorphism has not been consistently found to be associated with arterial thrombotic disease (41). Studies that have uncovered a connection were performed in selected populations, age <50 yr, and several studies reported a heightened risk among individuals with combined mutations of prothrombin 20210G/A polymorphism, factor V Leiden, and baseline cardiovascular risk factors (42,43). Tobacco use among younger women with these genetic mutations increases the risk of arterial thrombosis.

The biochemistry of thrombin generation and activity provides the underpinning for several readily measurable biomarkers. Factor Xa bound on a phospholipid surface with factor Va cleaves prothrombin at Arg 271 and Arg 320 to produce  $\alpha$ -thrombin (44,45). If only one cleavage occurs at Arg 320, the intermediate molecule meizothrombin is produced (46). This molecule remains bound to the phospholipid membrane and can cleave factor V and protein C; however, its activity toward fibrinogen is reduced. Once meizothrombin is cleaved at Arg 284,  $\alpha$ -thrombin is generated along with fragment 1.2, which is eventually cleaved by thrombin itself into fragments 1 and 2 (47,48). Several of these peptides have been used to evaluate the clinical significance of thrombin generation and activity, as well as their pharmacological inhibition in patients with coronary artery disease (CAD).

Unlike for fibrinogen, the evidence linking thrombin activity and/or generation to cardiovascular events has been modest and inconsistent. Thrombin generation, as measured by prothrombin fragments 1 and 2 and the thrombin–antithrombin complexes, is higher among patients with acute MI (AMI) and persists over time (49,50). In several small studies, markers of thrombin generation have correlated directly with future cardiovascular events (51–53). Simvastatin has been shown to decrease thrombin generation in hypercholesterolemic men; however, prospective trials evaluating the prognostic role of markers of thrombin generation in patients with and without coronary disease have not been performed. Additionally, there is no evidence of the effect of modulation of these markers and the potential additive role of these markers above known cardiovascular risk factors.

### ***Tissue Factor***

Tissue factor is a small transmembrane glycoprotein synthesized in subendothelial smooth muscle cells and monocytes and is also found circulating in procoagulant micro-

particles. The presence of tissue factor in the circulation initiates the coagulation cascade. Tissue factor is also produced in circulating monocytes and is involved in the pathobiology of atherothrombosis and several inflammatory disorders, such as systemic lupus erythematosus (54,55).

The tissue factor gene is found on chromosome 1, with a promoter region that allows the gene to be regulated in an inducible (monocytes and ECs) and constitutive manner (epithelial cells) (56). The promoter region has been found to exist in two different haplotypes with different polymorphisms (57). One of these haplotypes, 1208 D, leads to decreased serum levels of tissue factor and was not associated with coronary thrombosis in a case-control evaluation of patients with MI (57).

There is a moderate amount of data linking tissue factor with thrombogenicity. In elegant studies evaluating atherectomy specimens, tissue factor antigen was present in 40% of specimens in patients with unstable coronary syndromes compared with 12% in specimens from patients with stable disease (58). Higher levels of soluble tissue factor have been found in patients with AMI and unstable angina (59–61). Additionally, treatment with the antiplatelet agent ticlopidine and the antilipid therapy simvastatin reduces the level of circulating tissue factor (62,63). Direct antibody therapy aimed at local inhibition of tissue factor at the disrupted plaque has been developed (64). Prospective studies should be performed that correlate therapies that reduce circulating tissue factor with cardiovascular outcomes.

## ANTICOAGULATION SYSTEM BIOMARKERS

The physiological relevance of vascular surface thromboresistance cannot be overestimated, particularly in the context of atherosclerotic CAD. Compared to the traditional markers of thrombosis, measurements to determine the functionality of thromboresistance are based on individual contributing proteins. In some cases, an evaluation is challenged by the release of soluble forms of surface proteins that reflect vascular injury rather than availability for intrinsic anticoagulation or fibrinolysis.

### *Thrombomodulin*

Thrombomodulin is an integral membrane-bound receptor found on the surface of ECs that binds thrombin, accelerates thrombin-mediated protein C activation, and contributes to factor Va and factor VIIIa neutralization.

Genetic studies have identified two polymorphisms that may have potential clinical implications. A mutation at Ala455Val is reported to be associated with the occurrence of MI (65) and has been specifically associated with increased risk among African Americans (66). A mutation leading to an Ala25Thr substitution was found to increase the risk of MI, particularly in young male smokers, in the Study of Myocardial Infarction Leiden (43).

Clinical evidence supporting the link between thrombomodulin and MI does exist. In a large, prospective study of 14,170 patients participating in the Atherosclerosis Risk in Communities (ARIC) study who did not have a history of CVD, the 258 cases of incident CVD were associated with incrementally decreased levels of plasma thrombomodulin (67). The investigators concluded that in a population of patients without CHD, soluble thrombomodulin may reflect endothelial performance and, accordingly, a high concentration of plasma thrombomodulin may be associated with a decreased risk of CHD. These findings are intriguing and require verification in different populations.

### ***Plasminogen Activator Inhibitor-1/Tissue-Type Plasminogen Activator***

The endogenous fibrinolytic system is under meticulous control of clot-dissolving enzymes such as t-PA and inhibitors of these enzymes, such as PAI-1. This system represents the most studied of the anticoagulant systems regarding future cardiovascular risk.

PAI-1 is produced in the human vascular endothelial cell, the liver, and adipose tissue (68). PAI-1 is a serine protease that binds and irreversibly inhibits tPA from cleaving fibrin. Several genetic polymorphisms of PAI-1 have been identified, the most studied of which is a 4G/5G insertion/deletion polymorphism located in the promoter region of the gene (69). This polymorphism is associated with plasma levels of PAI-1 (70) and may also be related to the prothrombotic environment associated with insulin resistance in several populations (71–74). A meta-analysis of nine studies evaluating this PAI-1 polymorphism among more than 1500 cases and controls found a small increase, most pronounced in high-risk populations, in the outcome of MI with the mutation (75).

Prospective studies evaluating the predictive risk associated with increased plasma PAI-1 levels have been performed. In patients with acute ST-elevation MI, PAI-1 levels correlate with mortality (76). In young patients who survive MI, high PAI-1 levels have been reported in association with hypertriglyceridemia (77). Finally, in patients without a previous MI, increased PAI-1 levels in men were found to correlate with future MI (78). Future studies must consider carefully the independent prognostic value of PAI-1 levels above current clinical risk factors. A special emphasis should continue on patient populations with insulin resistance and metabolic syndrome.

### ***Tissue-Type Plasminogen Activator***

tPA, an important component of the fibrinolytic system, is synthesized by vascular endothelium and released on stimulation by local thrombotic signals. Once released, tPA binds fibrin and is cleaved to its active form, plasmin. Plasmin cleaves fibrin strands within the thrombus matrix to initiate the breakdown of clots. Plasma tPA rapidly binds PAI-1 and forms a complex that is much more stable than unbound tPA. Therefore, plasma tPA antigen levels may reflect increased PAI-1 activity or endothelial injury, potentially explaining a relationship between higher tPA levels and clinical outcome (79).

Several genetic mutations have been described with tPA, but the 311-bp Alu insertion/deletion is the most widely studied (80). Although initial reports found a relationship between this mutation and thrombosis (81), no relationship was found in the Physicians' Health Study (82). The mutation did not have any effect on plasma levels of tPA phenotype.

Prospective studies have evaluated plasma levels of tPA and their relationship to clinical outcomes. The Physicians' Health Study reported that an elevated plasma tPA antigen level in men was associated with an increased risk of MI (OR of 2.81 in the highest quartile) compared with matched controls (83). The ARIC study also found that plasma levels of tPA (and PAI-1) were associated with the incidence of CHD (84). In both studies, the relationship was no longer present after controlling for traditional risk factors.

## **PLATELET SURFACE MARKERS**

Platelets are known to play a pivotal role in arterial thrombosis. Indeed, the initial descriptions of “white clot” were based on the finding of significant platelet deposition. Recent studies have identified several important platelet surface receptors and proteins involved in thrombosis and cell–cell interactions. We discuss next the available data on

GpIIb/IIIa receptors and CD40 ligand (CD40L). P-selectin and vWF are included in the section on EC-surface makers, although they have significant interactions with platelets.

### *GpIIb/IIIa Receptors*

The platelet cell surface integrin GpIIb/IIIa is expressed by a platelet in response to numerous stimuli and binds fibrinogen to achieve bridging between adjacent platelets (aggregation). The iv GpIIb/IIIa receptor blockers are clinically useful in patients with acute coronary syndrome (ACS) and in patients undergoing percutaneous coronary interventions (85–89).

The genetic mutation most studied regarding the GpIIb/IIIa receptor is the T/C substitution in exon 2 that leads to an amino acid substitution and conformational change in the fibrinogen-binding site ( $\beta$ -3). This mutation, known as PIA1/A2 polymorphism, was initially associated with acute coronary thrombosis, with the greatest risk observed among patients under age 60 (90). Subsequent analyses of prospectively defined populations failed to identify a strong association (91,92).

Evaluation of platelet receptor performance, including GpIIb/IIIa, can be undertaken with flow cytometry. A measurable byproduct in plasma has not been described.

### *CD40 Ligand*

CD40L is a transmembrane protein that participates in both thrombosis and inflammation (93). It is a protein of the TNF family and found on the surface of inflammatory cells and activated platelets (94). Activated platelets release CD40L from stored granules on activation. The CD40L then binds the GpIIb/IIIa receptor, leading to its activation, platelet crosslinking, and platelet leukocyte interactions.

The plasma level of CD40L was evaluated in a population of patients with ACS treated with abciximab (95) and was found to be strongly associated with the rate of death and non-fatal MI. This risk was attenuated with abciximab treatment when compared in patients without elevated plasma CD40L (95). CD40L has strong potential as biomarker in the management of patients with CHD.

## EC MARKERS

The EC surface is the “command center” in determining the balance of hemostasis. When denuded or disrupted, this site becomes the nidus for thrombus formation. Accordingly, in EC-derived proteins, byproducts or remnants may represent biomarkers for atherothrombosis, including disease activity and response to therapy.

### *vWF and P-Selectin*

vWF is synthesized and released by the EC in response to stimulation or cell-surface injury. Collagen and plasma vWF are present at sites of denuded endothelium and serve as sites for platelet adhesion (15). Inhibition of the von Willebrand-cleaving protease has been implicated as the pathobiology of acute thrombotic thrombocytopenic purpura (96,97).

E-selectin is also synthesized by vascular ECs. A related protein, platelet P-selectin, has been associated with atherosclerotic lesion development (98). On release, P-selectin mediates platelet binding to the surface of ECs. The main ligand of P-selectin, P-selectin glycoprotein ligand 1, is present on the surface of both leukocytes and platelets. Both platelet and leukocyte rolling on the endothelial surface is mediated through this ligand-receptor interaction. P-selectin also activates leukocytes to form a P-selectin-Ig complex that induces the production of tissue factor-containing microparticles (99).

In this manner, both vWF and P-selectin are markers of EC activation and cell-cell interactions that participate in atherothrombosis. vWF plasma levels have been correlated to future cardiovascular events in patients without CAD (100–102) and in patients with ACS (103). A meta-analysis found a consistent and modest relationship between the levels of vWF and cardiovascular events (OR of 1.5) (104). P-selectin has not been investigated as extensively; however, levels have been shown to correlate with unsuccessful thrombolysis in patients with AMI (105).

Circulating vWF has also been found to have an acute-phase increase in patients with unstable angina and MI. Furthermore, in patients with this increased release of vWF within 48 h, there is impaired outcome at 30 d (106). Enoxaparin has been shown to reduce this vWF release and provide protection in patients with unstable angina and MI (107).

The available data demonstrate that EC-derived proteins may provide a biologically relevant “status report” of vascular pathology and atherothrombotic disease activity. Further prospective studies are required to better define their role as prognostic and treatment-responsive biomarkers that can be applied to clinical practice.

Finally, correlation of these molecules with circulating EC levels would provide the final physiological link to the initiation of thrombosis. Recent studies have demonstrated that vascular injury in the coronary tree triggers the production and release of ECs into the circulation, where they may function in a reparative role (107,108).

### *Circulating ECs*

The understanding of atherothrombosis as a combination of cell-cell interactions at the vascular endothelial surface has indicated to a central role for the EC. In fact, atherosclerosis is now thought of as a disease of the endothelium with progression dependent on replenishing endothelial progenitor cell levels from bone marrow (109). Therefore, circulating EC levels may indeed provide the ideal future biomarker of atherothrombosis.

Studies have demonstrated evidence of endothelial damage with circulating ECs in patients with AMI (110). Additionally, decreased circulating endothelial progenitor cells are associated with stable CAD and possible progression (111). Now that circulating levels of ECs can be measured, prospective studies are needed to determine the clinical utility of this potential ideal future biomarker.

## CURRENT LIMITATIONS

Several biomarkers of atherothrombosis exist. However, there are significant limitations to their widespread clinical utility. The ability to easily perform measurement of each biomarker remains difficult. Additionally, prospective assessment of the prognostic and diagnostic information offered by many of these biomarkers is required. Finally, significant work is required to evaluate the additive clinical effect of each biomarker in CVD.

The development of standard methods of measurement and reporting of biomarkers is also necessary. National integrated centers that combine clinical centers, biomarker core labs, and vascular thrombosis centers in order to obtain significant population data on biomarkers and clinical outcomes may be a catalyst for achieving these goals.

## CONCLUSION

The coagulation system is a delicate balance between procoagulant and anticoagulant mechanisms that are in a constant state of flux. Arterial thrombosis is initiated by vascular injury expressed by cell-surface markers on ECs and the collagen matrix underneath



denuded endothelium. Once initiated, the system rapidly amplifies the coagulation signal to the production of thrombin and platelet recruitment and aggregation. Simultaneously, mechanisms are initiated to reduce the explosive thrombosis signal through pathways such as thrombomodulin, antithrombin, and PAI. The end result when there is an imbalance in the system is arterial occlusion and circulatory collapse.

Review of the specific molecules involved in both coagulation and anticoagulation mechanisms in arterial thrombosis as biological markers of disease produces some central themes. The first is that genetic polymorphism of these coagulation molecules rarely leads to the phenotype of arterial thrombosis. This is in contradiction to venous thrombosis, in which genetic polymorphisms such as protein C, protein S, factor V Leiden, and prothrombin mutations significantly increase risk. The second important theme is that several of the molecules described as biomarkers provide prognostic information regarding future cardiovascular risk. However, to date, few markers provide prognostic information for patients with and without CAD that is independent of standard cardiovascular risk factors. Currently, fibrinogen represents the biomarker with the most prognostic data. Finally, the third central theme is one that focuses on the cell-based paradigm of thrombosis. In this paradigm, both the EC and the platelet occupy the central role. Significant research on thrombosis in the past has focused on platelet and platelet surface receptors. Recent research provides insight into the potential use of circulating EC levels and EC surface markers. It is likely that several of the molecules and cells discussed will play a role in the clinical care of patients with CHD in the future.

## REFERENCES

1. Becker RC, Bovill EG, Seghatchian MJ, Samama MM. Pathobiology of thrombin in acute coronary syndromes. *Am Heart J* 1998;136:S19–S31.
2. Rosenberg RD, Aird WC. Vascular-bed-specific hemostasis and hypercoagulable states. *N Engl J Med* 1999;340:1555–1564.
3. Hoffman M, Monroe DM 3rd. A cell-based model of hemostasis. *Thromb Haemost* 2001;85:958–965.
4. Drake TA, Morrissey JH, Edgington TS. Selective cellular expression of tissue factor in human tissues: implications for disorders of hemostasis and thrombosis. *Am J Pathol* 1989;134(5):1087–1097.
5. Narahara N, Enden T, Wiiger M, Prydz H. Polar expression of tissue factor in human umbilical vein endothelial cells. *Arterioscl Thromb* 1994;14(11):1815–1820.
6. Rapaport SI, Rao LV. The tissue factor pathway: how it has become a “prima ballerina.” *Thromb Haemost* 1995;74(1):7–17.
7. Ryan J, Brett J, Tijburg P, Bach RR, Kisiel W, Stern D. Tumor necrosis factor–induced endothelial tissue factor is associated with subendothelial matrix vesicles but is not expressed on the apical surface. *Blood* 1992;80(4):966–974.
8. Broze CJJ. The tissue factor pathway of coagulation. In: Loscalzo J, Schafer AI, eds. *Thrombosis and Hemorrhage*, 2nd ed. Williams & Wilkins, Baltimore, 1998, pp. 77–104.
9. Roberts HR, Monroe DM 3rd, Oliver JA, Chang JY, Hoffman M. Newer concepts in blood coagulation. *Haemophilia* 1998;4:331–334.
10. Sakariassen KS, Bolhuis PA, Sixma JJ. Human blood platelet adhesion to artery subendothelium is mediated by factor VIII–Von Willebrand factor bound to the subendothelium. *Nature* 1979;279:636–638.
11. Tschopp TB, Weiss HJ, Baumgartner HR. Decreased adhesion of platelets to subendothelium in von Willebrand’s disease. *J Lab Clin Med* 1974;83:296–300.
12. Wagner DD, Burger PC. Platelets in inflammation and thrombosis. *Arterioscl Thromb Vasc Biol* 2003;23:2131–2137.
13. Wagner DD, Olmsted JB, Marder VJ. Immunolocalization of von Willebrand protein in Weibel–Palade bodies of human endothelial cells. *J Cell Biol* 1982;95(1):355–360.
14. Wagner DD. The Weibel–Palade body: the storage granule for von Willebrand factor and P-selectin. *Thromb Haemost* 1993;70(1):105–110.

15. De Marco L, Girolami A, Russell S, Ruggeri ZM. Interaction of asialo von Willebrand factor with glycoprotein Ib induces fibrinogen binding to the glycoprotein IIb/IIIa complex and mediates platelet aggregation. *J Clin Invest* 1985;75:1198–1203.
16. Coughlin SR. Thrombin signalling and protease-activated receptors. *Nature* 2000;407:258–264.
17. Bajaj MS, Birktoft JJ, Steer SA, Bajaj SP. Structure and biology of tissue factor pathway inhibitor. *Thromb Haemost* 2001;86:959–972.
18. Perry DJ. Antithrombin and its inherited deficiencies. *Blood Rev* 1994;8:37–55.
19. Marcum JA, McKenney JB, Rosenberg RD. Acceleration of thrombin-antithrombin complex formation in rat hindquarters via heparinlike molecules bound to the endothelium. *J Clin Invest* 1984;74:341–350.
20. Esmon CT, Esmon NL, Harris KW. Complex formation between thrombin and thrombomodulin inhibits both thrombin-catalyzed fibrin formation and factor V activation. *J Biol Chem* 1982;257:7944–7947.
21. Esmon CT. Protein C anticoagulant pathway and its role in controlling microvascular thrombosis and inflammation. *Crit Care Med* 2001;29:S48–S51; discussion 51, 52.
22. Hoylaerts M, Rijken DC, Lijnen HR, Collen D. Kinetics of the activation of plasminogen by human tissue plasminogen activator: role of fibrin. *J Biol Chem* 1982;257:2912–2919.
23. Collen D. On the regulation and control of fibrinolysis: Edward Kowalski Memorial Lecture. *Thromb Haemost* 1980;43:77–89.
24. Voetsch B, Loscalzo J. Genetic determinants of arterial thrombosis. *Arterioscl Thromb Vasc Biol* 2004;24:216–229.
25. Lee AJ, Lowe GD, Smith WC, Tunstall-Pedoe H. Plasma fibrinogen in women: relationships with oral contraception, the menopause and hormone replacement therapy. *Br J Haematol* 1993;83:616–621.
26. Green F, Humphries S. Control of plasma fibrinogen levels. *Baillières Clin Haematol* 1989;2:945–959.
27. Ma J, Hennekens CH, Ridker PM, Stampfer MJ. A prospective study of fibrinogen and risk of myocardial infarction in the Physicians' Health Study. *J Am Coll Cardiol* 1999;33:1347–1352.
28. Scarabin PY, Aillaud MF, Amouyel P, et al. Associations of fibrinogen, factor VII and PAI-1 with baseline findings among 10,500 male participants in a prospective study of myocardial infarction—the PRIME Study. *Prospective Epidemiological Study of Myocardial Infarction*. *Thromb Haemost* 1998;80:749–756.
29. Sweetnam PM, Thomas HF, Yarnell JW, Beswick AD, Baker IA, Elwood PC. Fibrinogen, viscosity and the 10-year incidence of ischaemic heart disease [see comment]. *Eur Heart J* 1996;17:1814–1820.
30. Kannel WB, Wolf PA, Castelli WP, D'Agostino RB. Fibrinogen and risk of cardiovascular disease: the Framingham Study. *JAMA* 1987;258:1183–1186.
31. Yarnell JW, Baker IA, Sweetnam PM, et al. Fibrinogen, viscosity, and white blood cell count are major risk factors for ischemic heart disease: the Caerphilly and Speedwell collaborative heart disease studies [see comment]. *Circulation* 1991;83:836–844.
32. Woodward M, Lowe GD, Rumley A, Tunstall-Pedoe H. Fibrinogen as a risk factor for coronary heart disease and mortality in middle-aged men and women: the Scottish Heart Health Study. *Eur Heart J* 1998;19:55–62.
33. Meade TW, Mellows S, Brozovic M, et al. Haemostatic function and ischaemic heart disease: principal results of the Northwick Park Heart Study [see comment]. *Lancet* 1986;2:533–537.
34. Wilhelmsen L, Svardsudd K, Korsan-Bengtson K, Larsson B, Welin L, Tibblin G. Fibrinogen as a risk factor for stroke and myocardial infarction. *N Engl J Med* 1984;311:501–505.
35. Thompson SG, Kienast J, Pyke SD, Haverkate F, van de Loo JC. Hemostatic factors and the risk of myocardial infarction or sudden death in patients with angina pectoris. European Concerted Action on Thrombosis and Disabilities Angina Pectoris Study Group. *N Engl J Med* 1995;332:635–641.
36. Benderly M, Graff E, Reicher-Reiss H, Behar S, Brunner D, Goldbourt U. Fibrinogen is a predictor of mortality in coronary heart disease patients. The Bezafibrate Infarction Prevention (BIP) Study Group. *Arterioscl Thromb Vasc Biol* 1996;16:351–356.
37. Thompson SG, Fechtrup C, Squire E, et al. Antithrombin III and fibrinogen as predictors of cardiac events in patients with angina pectoris. *Arterioscl Thromb Vasc Biol* 1996;16:357–362.
38. Banerjee AK, Pearson J, Gilliland EL, et al. A six year prospective study of fibrinogen and other risk factors associated with mortality in stable claudicants. *Thromb Haemost* 1992;68:261–263.
39. Ericsson CG, Hamsten A, Nilsson J, Grip L, Svane B, de Faire U. Angiographic assessment of effects of bezafibrate on progression of coronary artery disease in young male postinfarction patients. *Lancet* 1996;347:849–853.
40. Ernst E, Resch KL. Fibrinogen as a cardiovascular risk factor: a meta-analysis and review of the literature. *Ann Int Med* 1993;118:956–963.

41. Reiner AP, Siscovick DS, Rosendaal FR. Hemostatic risk factors and arterial thrombotic disease. *Thromb Haemost* 2001;85:584–595.
42. Inbal A, Freimark D, Modan B, et al. Synergistic effects of prothrombotic polymorphisms and atherogenic factors on the risk of myocardial infarction in young males. *Blood* 1999;93(7):2186–2190.
43. Doggen CJ, Kunz G, Rosendaal FR, et al. A mutation in the thrombomodulin gene, 127G to A coding for Ala25Thr, and the risk of myocardial infarction in men. *Thromb Haemost* 1998;80:743–748.
44. Mann KG. Prothrombin and thrombin. In: Coleman RW, Hirsch J, Merder VJ, Salzman EW, eds. *Hemostasis and Thrombosis: Basic Principles and Clinical Practice*. Lippincott, Philadelphia, 1994, pp. 184–199.
45. Degen SJ, Davie EW. Nucleotide sequence of the gene for human prothrombin. *Biochemistry* 1987;26:6165–6177.
46. Doyle MF, Mann KG. Multiple active forms of thrombin. IV. Relative activities of meizothrombins. *J Biol Chem* 1990;265:10,693–10,701.
47. Mann KG, Yip R, Heldebrant CM, Fass DN. Multiple active forms of thrombin. 3. Polypeptide chain location of active site serine and carbohydrate. *J Biol Chem* 1973;248:1868–1875.
48. Mann KG, Heldebrant CM, Fass DN. Multiple active forms of thrombin. II. Mechanism of production from prothrombin. *J Biol Chem* 1971;246:6106–6114.
49. Reganon E, Vila V, Martinez-Sales V, Vaya A, Aznar J. Inflammation, fibrinogen and thrombin generation in patients with previous myocardial infarction. *Haematologica* 2002;87:740–745; discussion 745.
50. Figueras J, Monasterio Y, Lidon RM, Nieto E, Soler-Soler J. Thrombin formation and fibrinolytic activity in patients with acute myocardial infarction or unstable angina: in-hospital course and relationship with recurrent angina at rest. *J Am Coll Cardiol* 2000;36:2036–2043.
51. Ardissino D, Merlini PA, Gamba G, et al. Thrombin activity and early outcome in unstable angina pectoris. *Circulation* 1996;93:1634–1639.
52. Li YH, Teng JK, Tsai WC, et al. Prognostic significance of elevated hemostatic markers in patients with acute myocardial infarction. *J Am Coll Cardiol* 1999;33:1543–1548.
53. Galvani M, Ferrini D, Ottani F, Eisenberg PR. Early risk stratification of unstable angina/non-Q myocardial infarction: biochemical markers of coronary thrombosis. *Int J Cardiol* 1999;68:S55–S61.
54. Amengual O, Atsumi T, Khamashta MA, Hughes GR. The role of the tissue factor pathway in the hypercoagulable state in patients with the antiphospholipid syndrome. *Thromb Haemost* 1998;79:276–281.
55. Segal J, Kickler T, Petri M. Tissue factor activity in patients with systemic lupus erythematosus: association with disease activity. *J Rheumatol* 2000;27:2827–2832.
56. Moons AH, Levi M, Peters RJ. Tissue factor and coronary artery disease. *Cardiovasc Res* 2002;53:313–325.
57. Arnaud E, Barbalat V, Nicaud V, et al. Polymorphisms in the 5' regulatory region of the tissue factor gene and the risk of myocardial infarction and venous thromboembolism: the ECTIM and PATHROS studies. *Etude Cas-Temoins de l'Infarctus du Myocarde. Paris Thrombosis case-control Study. Arterioscl Thromb Vasc Biol* 2000;20:892–898.
58. Annex BH, Denning SM, Channon KM, et al. Differential expression of tissue factor protein in directional atherectomy specimens from patients with stable and unstable coronary syndromes. *Circulation* 1995;91:619–622.
59. Suefuji H, Ogawa H, Yasue H, et al. Increased plasma tissue factor levels in acute myocardial infarction. *Am Heart J* 1997;134:253–259.
60. Soejima H, Ogawa H, Yasue H, et al. Heightened tissue factor associated with tissue factor pathway inhibitor and prognosis in patients with unstable angina. *Circulation* 1999;99:2908–2913.
61. Misumi K, Ogawa H, Yasue H, et al. Comparison of plasma tissue factor levels in unstable and stable angina pectoris. *Am J Cardiol* 1998;81:22–26.
62. Marco J, Ariens RA, Fajadet J, et al. Effect of aspirin and ticlopidine on plasma tissue factor levels in stable and unstable angina pectoris. *Am J Cardiol* 2000;85:527–531.
63. Ferro D, Basili S, Alessandri C, Mantovani B, Cordova C, Violi F. Simvastatin reduces monocyte-tissue-factor expression type IIa hypercholesterolaemia. *Lancet* 1997;350(9086):1222.
64. Badimon JJ, Lettino M, Toschi V, et al. Local inhibition of tissue factor reduces the thrombogenicity of disrupted human atherosclerotic plaques: effects of tissue factor pathway inhibitor on plaque thrombogenicity under flow conditions. *Circulation* 1999;99:1780–1787.
65. Norlund L, Holm J, Zoller B, Ohlin AK. A common thrombomodulin amino acid dimorphism is associated with myocardial infarction. *Thromb Haemost* 1997;77:248–251.
66. Wu KK, Aleksic N, Ahn C, et al. Thrombomodulin Ala455Val polymorphism and risk of coronary heart disease. *Circulation* 2001;103:1386–1389.

67. Salomaa V, Matei C, Aleksic N, et al. Soluble thrombomodulin as a predictor of incident coronary heart disease and symptomless carotid artery atherosclerosis in the Atherosclerosis Risk in Communities (ARIC) Study: a case-cohort study. *Lancet* 1999;353:1729–1734.
68. Saksela O, Rifkin DB. Cell-associated plasminogen activation: regulation and physiological functions. *Ann Rev Cell Biol* 1988;4:93–126.
69. Dawson SJ, Wiman B, Hamsten A, Green F, Humphries S, Henney AM. The two allele sequences of a common polymorphism in the promoter of the plasminogen activator inhibitor-1 (PAI-1) gene respond differently to interleukin-1 in HepG2 cells. *J Biol Chem* 1993;268:10,739–10,745.
70. Dawson S, Hamsten A, Wiman B, Henney A, Humphries S. Genetic variation at the plasminogen activator inhibitor-1 locus is associated with altered levels of plasma plasminogen activator inhibitor-1 activity. *Arterioscl Thromb* 1991;11:183–190.
71. Festa A, D'Agostino R Jr, Rich SS, Jenny NS, Tracy RP, Haffner SM. Promoter (4G/5G) plasminogen activator inhibitor-1 genotype and plasminogen activator inhibitor-1 levels in blacks, Hispanics, and non-Hispanic whites: the Insulin Resistance Atherosclerosis Study. *Circulation* 2003;107:2422–2427.
72. Mansfield MW, Stickland MH, Grant PJ. Environmental and genetic factors in relation to elevated circulating levels of plasminogen activator inhibitor-1 in Caucasian patients with non-insulin-dependent diabetes mellitus. *Thromb Haemost* 1995;74:842–847.
73. Eriksson P, Nilsson L, Karpe F, Hamsten A. Very-low-density lipoprotein response element in the promoter region of the human plasminogen activator inhibitor-1 gene implicated in the impaired fibrinolysis of hypertriglyceridemia. *Arteriosclerosis, Thromb Vasc Biol* 1998;18:20–26.
74. Panahloo A, Mohamed-Ali V, Lane A, Green F, Humphries SE, Yudkin JS. Determinants of plasminogen activator inhibitor 1 activity in treated NIDDM and its relation to a polymorphism in the plasminogen activator inhibitor 1 gene. *Diabetes* 1995;44:37–42.
75. Iacoviello L, Burzotta F, Di Castelnuovo A, Zito F, Marchioli R, Donati MB. The 4G/5G polymorphism of PAI-1 promoter gene and the risk of myocardial infarction: a meta-analysis. *Thromb Haemost* 1998;80:1029–1030.
76. Collet JP, Montalescot G, Vicaud E, et al. Acute release of plasminogen activator inhibitor-1 in ST-segment elevation myocardial infarction predicts mortality [see comment]. *Circulation* 2003;108:391–394.
77. Hamsten A, Wiman B, de Faire U, Blombäck M. Increased plasma levels of a rapid inhibitor of tissue plasminogen activator in young survivors of myocardial infarction. *N Engl J Med* 1985;313:1557–1563.
78. Thøgersen AM, Jansson JH, Boman K, et al. High plasminogen activator inhibitor and tissue plasminogen activator levels in plasma precede a first acute myocardial infarction in both men and women: evidence for the fibrinolytic system as an independent primary risk factor. *Circulation* 1998;98:2241–2247.
79. Ridker PM, Brown NJ, Vaughan DE, Harrison DG, Mehta JL. Established and emerging plasma biomarkers in the prediction of first atherothrombotic events. *Circulation* 2004;108:6–19.
80. Ludwig M, Wohn KD, Schleuning WD, Olek K. Allelic dimorphism in the human tissue-type plasminogen activator (TPA) gene as a result of an Alu insertion/deletion event. *Hum Genet* 1992;88:388–392.
81. van der Bom JG, de Knijff P, Haverkate F, et al. Tissue plasminogen activator and risk of myocardial infarction: the Rotterdam Study. *Circulation* 1997;95:2623–2627.
82. Ridker PM, Baker MT, Hennekens CH, Stampfer MJ, Vaughan DE. Alu-repeat polymorphism in the gene coding for tissue-type plasminogen activator (t-PA) and risks of myocardial infarction among middle-aged men. *Arterioscl Thromb Vasc Biol* 1997;17:1687–1690.
83. Ridker PM, Vaughan DE, Stampfer MJ, Manson JE, Hennekens CH. Endogenous tissue-type plasminogen activator and risk of myocardial infarction. *Lancet* 1993;341:1165–1168.
84. Folsom AR, Aleksic N, Park E, Salomaa V, Juneja H, Wu KK. Prospective study of fibrinolytic factors and incident coronary heart disease: the Atherosclerosis Risk in Communities (ARIC) Study. *Arterioscl Thromb Vasc Biol* 2001;21:611–617.
85. The PURSUIT Investigators. Inhibition of platelet glycoprotein IIb/IIIa with eptifibatid in patients with acute coronary syndromes. *N Engl J Med* 1998;339:436–443.
86. The EPIC Investigators. Use of a monoclonal antibody directed against the platelet glycoprotein IIb/IIIa receptor in high-risk coronary angioplasty. *N Engl J Med* 1994;330:956–961.
87. The EPILOG Investigators. Platelet glycoprotein IIb/IIIa receptor blockade and low-dose heparin during percutaneous coronary revascularization. *N Engl J Med* 1997;336:1689–1696.
88. The EPILOG Investigators. Inhibition of the platelet glycoprotein IIb/IIIa receptor with tirofiban in unstable angina and non-Q-wave myocardial infarction. *N Engl J Med* 1998;338:1488–1497.
89. Kong DF, Califf RM, Miller DP, et al. Clinical outcomes of therapeutic agents that block the platelet glycoprotein IIb/IIIa integrin in ischemic heart disease. *Circulation* 1998;98:2829–2835.

90. Weiss EJ, Bray PF, Tayback M, et al. A polymorphism of a platelet glycoprotein receptor as an inherited risk factor for coronary thrombosis. *N Engl J Med* 1996;334:1090–1094.
91. Ridker PM, Hennekens CH, Schmitz C, Stampfer MJ, Lindpaintner K. PIA1/A2 polymorphism of platelet glycoprotein IIIa and risks of myocardial infarction, stroke, and venous thrombosis. *Lancet* 1997; 349:385–388.
92. Poirier O, Georges JL, Ricard S, et al. New polymorphisms of the angiotensin II type 1 receptor gene and their associations with myocardial infarction and blood pressure: the ECTIM study. *Etude Cas-Temoin de l'Infarctus du Myocarde. J Hypertens* 1998;16:1443–1447.
93. Andre P, Prasad KS, Denis CV, et al. CD40L stabilizes arterial thrombi by a beta3 integrin—dependent mechanism. *Nat Med* 2002;8:247–252.
94. Henn V, Slupsky JR, Grafe M, et al. CD40 ligand on activated platelets triggers an inflammatory reaction of endothelial cells. *Nature* 1998;391:591–594.
95. Heeschen C, Dimmeler S, Hamm CW, et al. Soluble CD40 ligand in acute coronary syndromes. *N Engl J Med* 2003;348:1104–1111.
96. Tsai HM, Lian EC. Antibodies to von Willebrand factor-cleaving protease in acute thrombotic thrombocytopenic purpura. *N Engl J Med* 1998;339:1585–1594.
97. Furlan M, Robles R, Galbusera M, et al. von Willebrand factor-cleaving protease in thrombotic thrombocytopenic purpura and the hemolytic-uremic syndrome. *N Engl J Med* 1998;339:1578–1584.
98. Burger PC, Wagner DD. Platelet P-selectin facilitates atherosclerotic lesion development. *Blood*. 2003; 101:2661–2666.
99. Hrachovinova I, Cambien B, Hafezi-Moghadam A, et al. Interaction of P-selectin and PSGL-1 generates microparticles that correct hemostasis in a mouse model of hemophilia A. *Nat Med* 2003;9:1020–1025.
100. Blann AD, Miller JP, McCollum CN. von Willebrand factor and soluble E-selectin in the prediction of cardiovascular disease progression in hyperlipidaemia. *Atherosclerosis* 1997;132:151–156.
101. Morange PE, Simon C, Alessi MC, et al. Endothelial cell markers and the risk of coronary heart disease: the Prospective Epidemiological Study of Myocardial Infarction (PRIME) study. *Circulation* 2004;109: 1343–1348.
102. Blann AD, de Romeuf C, Mazurier C, McCollum CN. Circulating von Willebrand factor antigen II in atherosclerosis: a comparison with von Willebrand factor and soluble thrombomodulin. *Blood Coagulation Fibrinolysis* 1998;9:261–266.
103. Montalescot G, Philippe F, Ankri A, et al. Early increase of von Willebrand factor predicts adverse outcome in unstable coronary artery disease: beneficial effects of enoxaparin. French Investigators of the ESSENCE Trial. *Circulation* 1998;98:294–299.
104. Whincup PH, Danesh J, Walker M, et al. von Willebrand factor and coronary heart disease: prospective study and meta-analysis. *Eur Heart J* 2002;23:1764–1770.
105. Gurbel PA, Serebruany VL, Shustov AR, et al. Increased baseline levels of platelet P-selectin, and platelet-endothelial cell adhesion molecule-1 in patients with acute myocardial infarction as predictors of unsuccessful thrombolysis. *Coron Artery Dis* 1998;9:451–456.
106. Montalescot G, Collet JP, Lison L, et al. Effects of various anticoagulant treatments on von Willebrand factor release in unstable angina. *J Am Coll Cardiol* 2000;36:110–114.
107. Badorff C, Brandes RP, Popp R, et al. Transdifferentiation of blood-derived human adult endothelial progenitor cells into functionally active cardiomyocytes. *Circulation* 2003;107:1024–1032.
108. Francis S. Endothelial progenitor cells and coronary artery disease. *Heart (British Cardiac Society)* 2004; 90:591–592.
109. Goldschmidt-Clermont PJ. Loss of bone marrow-derived vascular progenitor cells leads to inflammation and atherosclerosis. *Am Heart J* 2003;46(4 Suppl):S5–12.
110. Mutin M, Canavy I, Blann A, Bory M, Sampol J, Dignat-George F. Direct evidence of endothelial injury in acute myocardial infarction and unstable angina by demonstration of circulating endothelial cells. *Blood* 1999;93:2951–2958.
111. Eizawa T, Ikeda U, Murakami Y, et al. Decrease in circulating endothelial progenitor cells in patients with stable coronary artery disease. *Heart* 2004;90(6):685–686.
112. Becker RC. Antithrombotic therapy after myocardial infarction. *N Engl J Med* 2002;347:1019–1022.

# 27

---

## Measures of Platelet Activation and Aggregation

---

*Jean-Philippe Collet, MD, PhD  
and Gilles Montalescot, MD, PhD*

### CONTENTS

INTRODUCTION  
HOW THE PLATELET PLUG FORMS  
THE DIFFERENT TYPES OF PLATELET ASSAYS  
WHAT ARE THE KEY ISSUES OF PLATELET MONITORING  
FOR THE CARDIOLOGIST?  
CONCLUSION  
REFERENCES

---

### SUMMARY

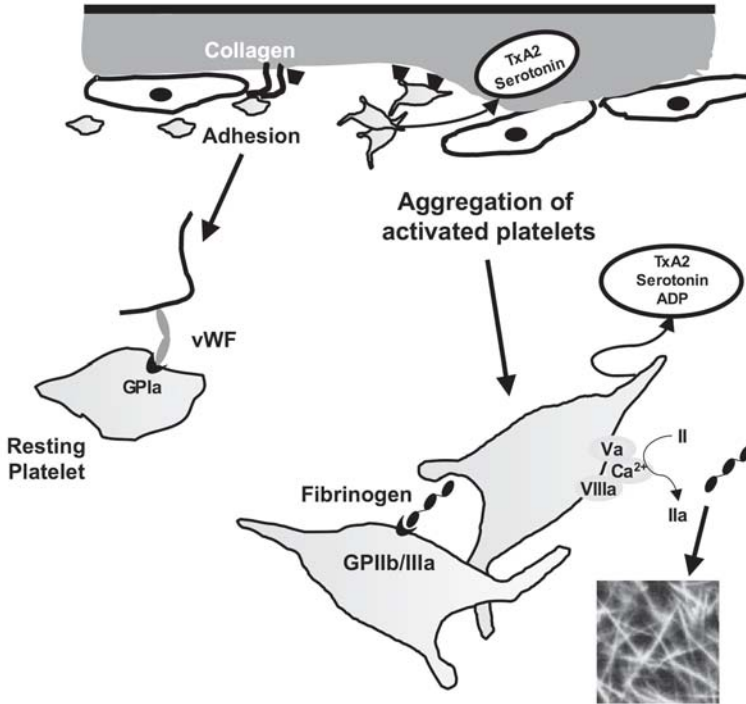
Platelets play a key role in the pathophysiology of cardiovascular disease. Disrupting platelet activation and aggregation with antiplatelet agents is effective both for primary and secondary prevention of atherothrombotic events, and has become a cornerstone of cardiovascular disease management nowadays. Identifying hyperactive platelets as predictors of a thrombotic tendency and monitoring the response to antiplatelet agents have become the key objectives of platelet function monitoring. We have learned more about the variable response to antiplatelet drugs as more accurate and reliable platelet function assays have been developed. However, there are currently no data establishing a cause-and-effect relationship or allowing for the establishment of an algorithm for treatment in response to measured platelet function inhibition.

**Key Words:** Platelet; thrombus; aggregation; atherothrombosis; antiplatelet agents.

### INTRODUCTION

Platelets play a key role in the pathophysiology of cardiovascular disease (CVD). Disrupting platelet activation and aggregation with antiplatelet agents is effective for both primary and secondary prevention of atherothrombotic events and has become a cornerstone of CVD management nowadays (1). Originally, identifying the causes of abnormal bleeding and predicting normal hemostasis after surgery were the major goals of platelet function

From: *Contemporary Cardiology:  
Cardiovascular Biomarkers: Pathophysiology and Disease Management*  
Edited by: David A. Morrow © Humana Press Inc., Totowa, NJ



**Fig. 1.** Pathophysiology of platelet plug formation.

testing. In the modern era of cardiology, identifying hyperactive platelets as predictors of a thrombotic tendency and monitoring the response to antiplatelet agents have become the key objectives. The aim of this chapter is to provide an overview of platelet function monitoring in the clinical care of patients with CVD.

## HOW THE PLATELET PLUG FORMS

Formation of the hemostatic plug at sites of vascular injury begins with the arrest of circulating platelets on exposed collagen and continues with the recruitment of additional platelets into a growing platelet mass that will eventually be stabilized with crosslinked fibrin (Fig. 1) (2). Formation of a platelet plug can be thought of as occurring in three phases: initiation, extension, and perpetuation.

The *initiation* of platelet plug formation occurs when circulating platelets arrest and are activated by exposed collagen and von Willebrand factor (vWF), allowing the accumulation of a platelet monolayer that supports thrombin generation and the formation of platelet aggregates. Key to this phase of platelet activation is the presence of receptors on the platelet surface that can bind to collagen (integrin  $\alpha 2\beta 1$  and glycoprotein [GP] VI) and vWF (GpIb-IX-V and GpIIb/IIIa) and initiate intracellular signaling (3). Activation *in vivo* is enhanced by the formation and liberation of thromboxane A<sub>2</sub> (TXA<sub>2</sub>), the secretion of adenosine 5'-diphosphate (ADP) and serotonin from the platelet-dense granules, and the exposure of a procoagulant surface that promotes the generation of thrombin, the most powerful platelet-activating agent (4). All the platelet-aggregating agents act synergistically, so that if one of the pathways of aggregation is defective or inhibited, platelet function may be greatly impaired.

*Extension* occurs when additional platelets accumulate on the initial monolayer, a process for which GpIIb/IIIa activation is necessary, but not sufficient. Key to this phase is the presence of receptors on the platelet surface that can respond rapidly to locally generated thrombin, secreted ADP, and released TXA<sub>2</sub> to activate concentration and suppress synthesis of cyclic adenosine monophosphate. Because platelets have receptors for TXA<sub>2</sub> and ADP, platelets flowing by the damaged site are stimulated to change shape, extend pseudopods, and form an aggregate around the adherent platelets (5).

*Perpetuation* prevents premature disaggregation of the platelet plug. Recent studies point to a central role for outside-in signaling through cell-surface integrins. Platelets localize, amplify, and sustain the coagulant response at the injury site and release procoagulant platelet-derived microparticles (6,7).

Platelet aggregation requires a change in the conformation of the integrin GpIIb/IIIa, a heterodimer on the surface of platelets, into a form that serves as a receptor for fibrinogen and, under some conditions, vWF. Each of these proteins can form bridges between adjacent, stimulated platelets (8). When platelets are stimulated by agonists such as collagen and thrombin that cause the secretion of granule contents, a transbilayer flip of membrane phospholipids occurs that brings procoagulant phospholipids, principally phosphatidylserine, to the platelet surface. Microparticles with procoagulant activity are also formed. The exposed phosphatidylserine greatly accelerates the tenase and prothrombinase reactions of the coagulation pathway, resulting in the generation of thrombin, the most potent platelet agonist (9). Thrombin acts by cleaving protease-activated receptors on the platelet surface (10), resulting in activation of GpIIb/IIIa, formation of TXA<sub>2</sub>, and secretion of granule contents. Thrombin also converts fibrinogen into fibrin, which forms in and around the mass of aggregated platelets and confers stability to the hemostatic plug or thrombus. The formation of TXA<sub>2</sub> in platelets occurs when arachidonic acid is freed from membrane phospholipids by phospholipase A<sub>2</sub>. Under the influence of the enzymes cyclooxygenase (COX-1) and thromboxane synthase, arachidonic acid is converted into TXA<sub>2</sub>, a short-lived agonist that rapidly gives rise to the inactive, stable product, 11-dehydro thromboxane B<sub>2</sub> levels (TXB<sub>2</sub>). COX is irreversibly inactivated by aspirin, so the ability of platelets to form TXA<sub>2</sub> is inhibited for the remainder of their time in the circulation (11).

## THE DIFFERENT TYPES OF PLATELET ASSAYS

Many assays are available to monitor the status of a patient's platelets. However, they all measure different properties and, therefore, give a different picture of the platelet. Some indicate that platelet function has been inhibited to a certain extent. Others measure key biochemical markers (enzyme-linked immunosorbent assay or flow cytometry) allowing the detection of platelet activation before any physiological assays.

### *Bleeding Time*

The oldest test of platelet function is the bleeding time. It is easy and fast, does not require processing of the blood (12); is dependent on the skill of the technician, skin thickness, temperature, and platelet count; but is a poor indicator of the risk of bleeding or ischemic events and lacks consistency (13).

### *Platelet Function Analyzer-100*

The Platelet Function Analyzer-100 (PFA-100; Dade Behring) provides a quantitative measure of primary platelet-related hemostasis at high shear stress (14). It is a rapid, simple,



and reproducible test. A total of 0.8 mL of citrated whole blood is transferred into the reservoir of a disposable test cartridge within 4 h of blood sampling. The anticoagulated blood is warmed to 37°C and drawn under vacuum through a 200- $\mu\text{m}$ -diameter stainless steel capillary (that mimics a small or stenotic blood vessel) and a 150- $\mu\text{m}$ -diameter aperture in a nitrocellulose membrane coated with collagen and epinephrine (CEPI) or collagen and ADP (CADP). In response to the high shear rates of 5000–6000  $\text{s}^{-1}$  and the agonists, a platelet aggregate forms that blocks blood flow through the aperture; the time taken to occlude the aperture is reported as the closure time and is measured to a maximum of 300 s.

Platelets initially adhere to the collagen in the membrane by an interaction between GpIb/IX/V and vWF as well as by direct binding through GpIa/IIa; vWF, rather than fibrinogen, is the adhesive protein involved in binding to GpIIb/IIIa on activated platelets, resulting in aggregation. Citrate concentration, as well as the platelet count ( $<50 \leftrightarrow 10^9 \text{ l}^{-1}$ ) and hematocrit ( $<25\%$ ), can affect the closure time. Prolonged closure times with only the CEPI cartridge are observed with mild inherited platelet function disorders (e.g., storage pool disorders) and with aspirin ingestion, whereas prolonged closure times with both CEPI and CADP cartridges are found with more severe inherited platelet dysfunctions and with von Willebrand Disease (vWD) (15). Indeed, the PFA-100 appears to be a useful screening tool for vWD (16). It has also been used for monitoring GpIIb/IIIa antagonists in patients undergoing percutaneous transluminal coronary angioplasty (17) and for identifying of aspirin resistance (18).

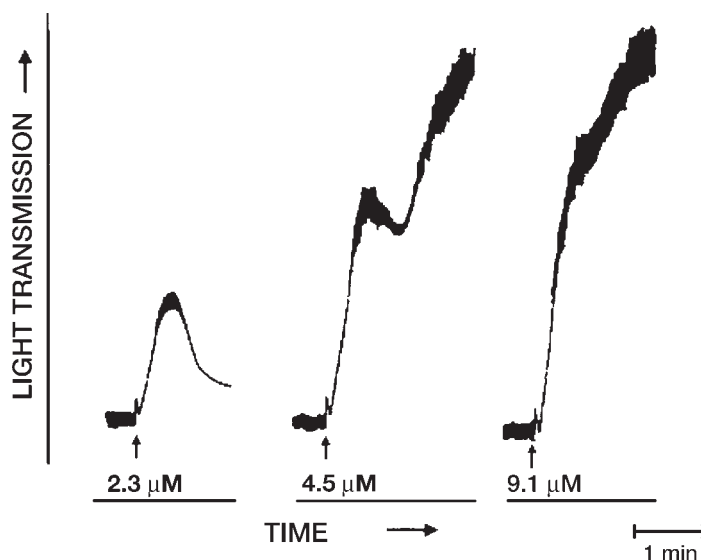
### *Platelet Aggregation Assays*

Of all the functional responses of platelets, aggregation is probably the mostly widely investigated. This focus derives largely from the fact that antiplatelet and antithrombotic drugs are characterized essentially as antiaggregatory agents. Development of the technique of turbidimetric aggregometry has greatly facilitated the investigation of platelet aggregation and, therefore, the development of antiplatelet agents (19).

### *Platelet Aggregation*

One milliliter (or 0.5 mL) of platelet-rich plasma (PRP) (obtained by centrifuging anticoagulated blood for 15 min at 135g and 37°C) is placed in a cuvet containing a metal stir bar (20). In an aggregometer, the stir bar is rotated magnetically at 1100 rpm, and light transmission through the PRP is recorded by a photometer. On the addition of most aggregating agents, the platelets change shape from discs to a more rounded form with pseudopods, resulting in a transient, small decrease in light transmission that is followed by a large increase as the platelets aggregate; the rate and extent of the increase in light transmission are measured. Platelet aggregation is highly variable within patient populations, is highly dependent on the skill and experience of the investigators performing the measurements, and may be affected by the preparation and handling of blood samples (21). It is affected by very low platelet counts ( $<100 \leftrightarrow 10^9 \text{ L}^{-1}$ ) and the concentration of agonist. High concentrations of all these agonists are associated with the formation of  $\text{TXA}_2$ , the secretion of granule contents, and the appearance of P-selectin on the platelet surface.

ADP is a weak agonist compared with collagen or thrombin. In citrated PRP, low concentrations of ADP cause only a primary, incomplete, reversible phase of aggregation, but at concentrations above 1–3  $\mu\text{M}$ , primary aggregation of human platelets does not reverse and is followed by a secondary, irreversible phase (Fig. 2). This biphasic aggregation depends on  $\text{TXA}_2$  formation. At high concentrations of ADP, the two phases fuse, result-



**Fig. 2.** ADP-induced aggregation in citrated PRP, showing primary phase of aggregation induced by low concentration of ADP (**left**), primary aggregation followed by secondary wave induced by slightly higher concentration of ADP (**middle**), and fusion of two phases of aggregation at high concentration of ADP (**right**). The arrows indicate the points of addition of ADP.

ing in a smooth aggregation curve resembling that seen on stimulation with collagen or thrombin. The drugs ticlopidine and clopidogrel act through this receptor to cause a similar selective inhibition of responses to ADP. Drugs that inhibit TXA<sub>2</sub> formation, such as aspirin, prevent the secondary phase of ADP-induced aggregation.

The weak agonist epinephrine (5–10 μM) aggregates platelets in citrated PRP without an initial change in platelet shape, but epinephrine is the least consistent agonist. If a subject has taken aspirin or other drugs that inhibit TXA<sub>2</sub> formation, the platelets will not aggregate in response to any concentration of epinephrine. Aspirin and other drugs that inhibit TXA<sub>2</sub> formation can block aggregation in response to low concentrations of collagen, although platelets change shape.

Thrombin receptor-activating peptide (TRAP) mimics the strong aggregating effect of thrombin on platelets. The response is only slightly reduced when TXA<sub>2</sub> formation is blocked. Secretion defects, particularly the lack of the potentiating effects of ADP from the dense granules, result in abnormal patterns of aggregation characterized by a normal primary phase but absent secondary phase, and impaired aggregation induced by low concentrations of collagen or TRAP.

#### WHOLE-BLOOD PLATELET AGGREGATION

Platelet aggregation is measured in diluted, anticoagulated whole blood by impedance aggregometry. Two electrodes are immersed in the sample, and when a current is passed through it, platelets adhere to the electrodes. On the addition of an aggregating agent with stirring, platelets aggregate around the platelets on the electrodes, and the rate and extent of the increase in impedance are recorded. The advantages of this test are that the preparation of PRP is avoided, and platelet function in lipemic blood can be evaluated. Again, the test is not suitable at very low platelet counts (22).

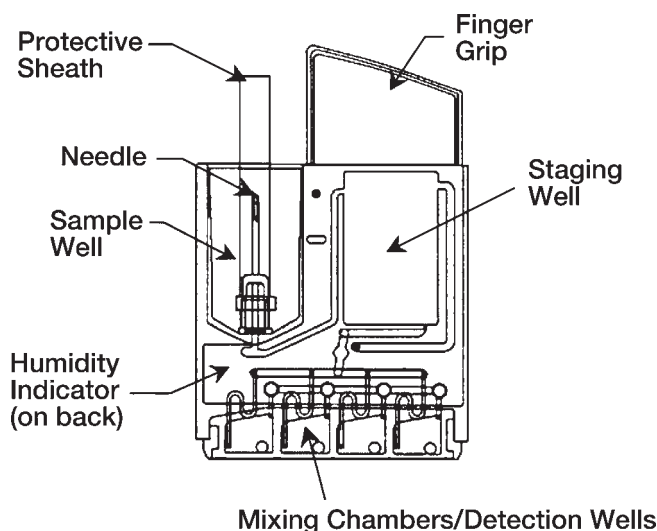


Fig. 3. Schematic of RPFA device.

### ULTEGRA RAPID PLATELET FUNCTION ASSAY

The Ultegra Rapid Platelet Function Assay (RPFA) provides a simple, rapid, accurate measure of platelet function that is used at the bedside to monitor patients receiving treatment with GpIIb/IIIa antagonists (23,24). Immediately after blood has been taken into citrate, 0.16-mL samples are drawn into two sample channels in a disposable cartridge (Fig. 3). The blood is mixed with the platelet agonist (iso-S) FLLRN and fibrinogen-coated polystyrene beads for 70 s by movement of a microprocessor-driven steel ball, and light transmission through the sample is measured. Agglutination occurs between the activated platelets and the fibrinogen-coated beads such that they fall out of suspension, leading to an increase in light transmission. The rate and extent of agglutination are used to calculate the platelet aggregation unit, which decreases in the presence of GpIIb/IIIa antagonists, because agglutination occurs in direct proportion to the number of unblocked GpIIb/IIIa receptors on the activated platelets. It has been used successfully to monitor the inhibitory effects of the GpIIb/IIIa antagonists (25,26).

### *Flow Studies in Platelet Aggregation*

In vivo, the extent of platelet adhesion and aggregation depends on receptor–ligand interactions that are exposed to a broad range of shear stresses generated by blood flow (up to 40,000/s in stenotic arteries). The development of in vitro methodologies mimicking pathophysiological flow conditions has significantly improved the understanding of the role of shear in regulating platelet functional responses (27).

In general, the effects of shear stress have been studied with platelets in suspension using rotational devices such as the Couette or the cone and plate(let) analyzer (CPA). The CPA device induces laminar flow with a uniform shear stress over a plate surface covered by a rotating cone. CPA is fast and simple. A small volume (0.2 mL) of citrated whole blood is applied to the polystyrene plate and is subjected to a defined shear rate of 1800 s<sup>-1</sup> for 2 min, followed by staining. Adherent platelets and platelet aggregates are evaluated by an image analyzer that provides a size distribution histogram, the percentage of surface

coverage, and average size of the stained objects (28). The CPA can be useful in testing antiplatelet therapies, and in detecting prothrombotic states in which there is platelet hyperfunction (e.g., diabetes) (28).

Thrombus formation involves the progressive accrual of platelets onto vascular subendothelium and subsequently onto immobilized platelets. Until recently, the morphometric and quantitative assessment of platelet adhesion and thrombus formation under high magnification has been limited to fixed samples. However, the advent of high-resolution microscopy techniques now enables the direct visualization of platelet adhesion processes down to a single-cell level in real time.

### *Flow Cytometry*

Flow-cytometric measurement of platelet-surface glycoproteins in unfixed whole blood is a rapid, sensitive, and quantitative method that enables simultaneous analysis of multiple aspects of platelet biology to be conducted on large numbers of single platelets in a short time (29). It can be carried out in small samples of whole blood, and thrombocytopenic samples can be analyzed. It enables 100% of the platelet population to be studied, including giant platelets, platelet-derived microparticles, and platelet-leukocyte aggregates. Analysis of unfixed blood samples allows investigation of the platelet response to agonist stimulation. Finally, platelets are studied in autologous plasma and in the presence of the other blood cells, which can contribute to the overall platelet response through the release of soluble mediators.

Usually, the platelets are labeled with two monoclonal antibodies (MAbs) conjugated to fluorophores with different emission spectra (30). Platelets are identified by the fluorescence of the platelet identifier. The fluorescence emitted by the second MAb is directly proportional to the density of the epitope of interest and is evaluated by acquiring several thousand platelet events. If the expression of the epitope of interest changes with time (e.g., by trafficking of membrane glycoproteins), platelets can be fixed before staining (30). Platelets can also be fixed after staining if immediate access to a flow cytometer is delayed.

Many fluorescently conjugated antibody- and nonantibody-based probes are available to label platelet epitopes. In addition to MAbs that bind glycoproteins on resting platelets, there are activation-dependent MAbs that detect conformational changes in glycoproteins (e.g., PAC1 for GpIIb/IIIa) or the expression of granule membrane proteins (e.g., anti-P-selectin). Nonantibody probes include PKH lipophilic dyes of membranes; the protein label biotin, which is detected by fluorescently conjugated streptavidin; and fluorescently conjugated annexin V, which detects exposure of the procoagulant surface after platelet activation (31).

Clinically, flow cytometry is useful in assessing the extent of platelet activation *ex vivo* and the sensitivity of platelets to added agonists *in vitro*. It has been used to show activated platelets in patients with unstable angina, acute myocardial infarction (AMI), stable coronary disease, and coronary angioplasty (32–34). It has also been used to assess differences between anticoagulation regimen in patients with non-ST-elevation acute coronary syndrome (ACS) (35). The randomized study ARMADA ( $n = 141$ ) identified markers of blood cell activation that independently predict outcomes at 1 mo. Enoxaparin, dalteparin, and unfractionated heparin (UFH) were compared in terms of efficacy, safety, and effects on any such markers. Using multivariate analysis, increased plasma levels of vWF, decreased platelet levels of GpIb/IX complexes, and monocyte tissue factor expression were identified as independent predictors of adverse outcomes at 1 mo. Enoxaparin and

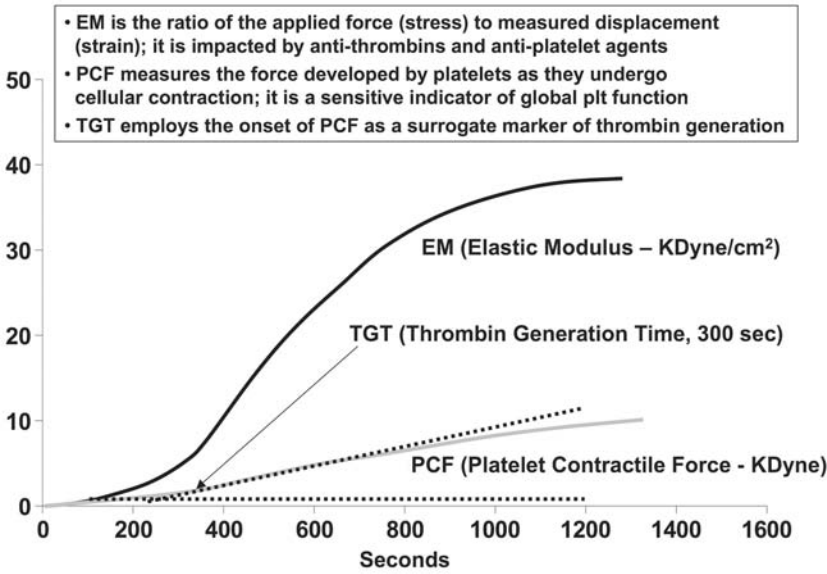


Fig. 4. Mechanical assessment of platelet function (36).

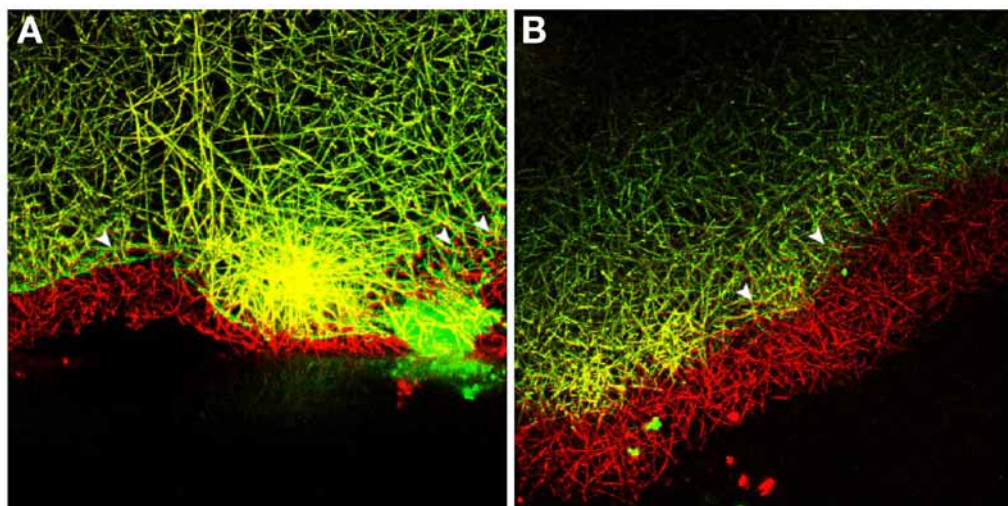
dalteparin reduced the release of vWF compared with UFH. Enoxaparin had a more favorable effect on GpIb/IX complexes than dalteparin or UFH.

### *Assessment of Mechanical Properties of Platelets*

Because they are performed on anticoagulated blood, aggregation studies cannot be used to test platelets under conditions of maximal activation, and they are incapable of assessing the role of platelets in thrombin production (36).

Assays capable of assessing platelet function during clotting and thus allowing measurement of the contribution of platelets to thrombin generation are available. Because platelets are monitored in the presence of thrombin, the test gages platelets under conditions of maximal activation. Different parameters are simultaneously assessed on one 700- $\mu$ L sample of citrated whole blood. Platelet contractile force (PCF), the force produced by platelets during clot retraction, is sensitive to platelet number, GpIIb/IIIa status, and the presence of antithrombin activities. Clot elastic modulus (CEM) is sensitive to fibrinogen concentration, platelet concentration, rate of thrombin generation, and production of force by platelets. Finally, the thrombin generation time (TGT) is determined from the PCF kinetics curve (Fig. 4). Because PCF is absolutely thrombin dependent (no thrombin, no force), the initial upswing in PCF occurs at the moment of thrombin production. The combination of PCF, CEM, and TGT measured on the same sample may allow rapid assessment of global hemostasis and the response to a variety of procoagulant and antithrombotic medications. Because PCF is relatively insensitive to fibrinogen concentration, the combination of PCF and CEM allows a degree of separation of clot structure from platelet effects. However, the direct establishment of the degree of risk associated with increasingly abnormal assay values needs to be established in clinical trials.

This type of investigation has been correlated with morphological analysis of ex vivo blood clots, assessed by confocal microscopy, in patients with AMI. The impact of both platelets and IIb/IIIa receptor antagonists on physical properties of platelet-rich clots as well as fibrinolysis has been successfully investigated (37–39). These new techniques are



**Fig. 5.** Dynamic assessment of impact of both platelets and IIb/IIIa receptor antagonists on lysis speed using confocal microscopy (38). (A) Lysis speed is decreased around platelet-rich areas. (B) The use of IIb/IIIa receptor antagonists decreases the size of platelet-rich areas, giving rise to a more homogeneous architecture of the fibrin network, which is more sensitive to the effect of lytics. The photographs represent an overlap (arrowheads) of the same clot taken 5 min apart.

easy to perform and effective in assessing the properties of new antiplatelet agents administered in addition to recommended antithrombotic therapy in patients with ACS (Fig. 5).

### *Procoagulant Surface Expression*

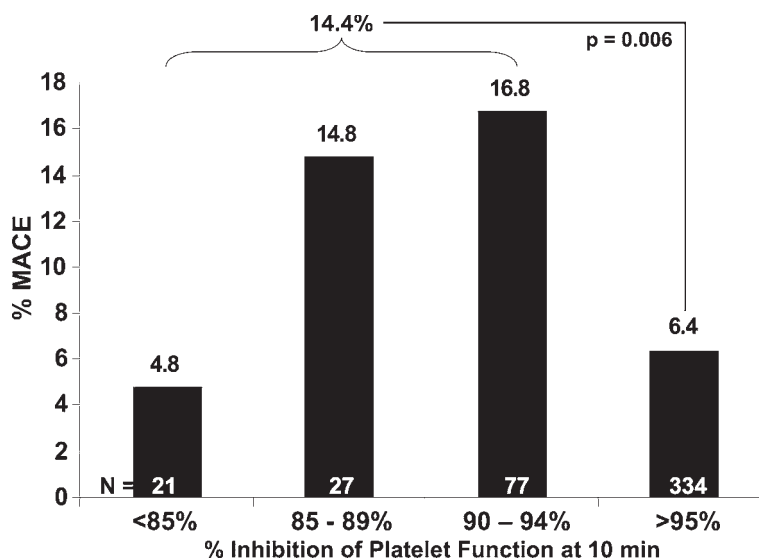
Phosphatidylserine that becomes exposed on the surface of activated platelets can be detected by flow cytometry using fluorescently labeled annexin V (31); alternatively, the thrombin-generating activity of the procoagulant surface can be measured with a chromogenic prothrombinase assay (40).

## WHAT ARE THE KEY ISSUES OF PLATELET MONITORING FOR THE CARDIOLOGIST?

### *Monitoring IIb/IIIa Receptor Antagonists*

GpIIb/IIIa antagonists prevent thrombus formation in proportion to their blockade of the approx 80,000 GpIIb/IIIa receptors present on the platelet surface (41). The most widely used method to monitor GpIIb/IIIa-receptor antagonists (RA) is turbidimetric aggregometry. Early studies found that inhibition of 50% of the GpIIb/IIIa receptors was needed to detect significant inhibition of ADP-induced platelet aggregation, whereas blockade of  $\oplus 80\%$  of the receptors completely abolished ADP-induced platelet aggregation, suggesting a steep dose–response curve.

Many factors may influence platelet aggregation measurements, including the number of receptors on platelets at the time of blood sampling. A significant example is the citrate anticoagulation that reduces the ionized calcium concentration normally found in blood. It has been found to enhance artificially the apparent activity of eptifibatide in ex vivo measurements (42). It has been suggested that this phenomenon led to underdosing with eptifibatide in the IMPACT II trial (43), which was subsequently corrected with the higher



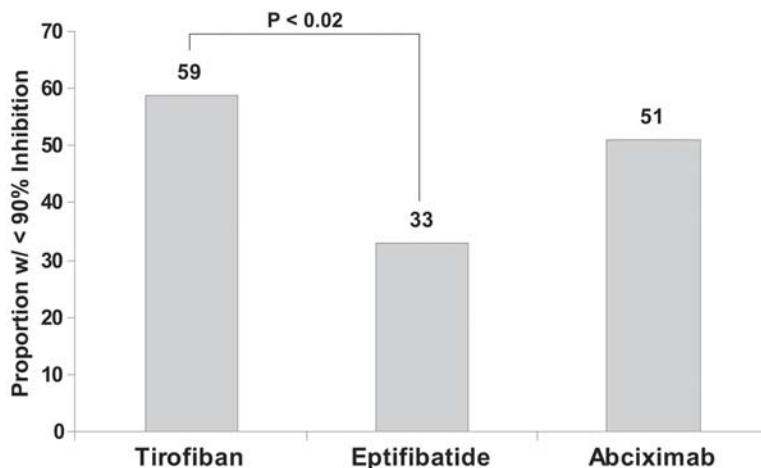
**Fig. 6.** Results of GOLD study showing clinical outcomes as function of platelet function inhibition with RPFa assay (26). MACE, major adverse coronary events.

dose chosen in the PURSUIT trial (44). Because of these variables in platelet aggregometry measurements, it is unclear which combination of conditions best reflects the effects of inhibitors in vivo.

Measurement of the degree of receptor occupancy by various agents of the GpIIb/IIIa inhibitor class has been proposed to be an alternate surrogate (45). Although dose–response curves for GpIIb/IIIa antagonist inhibition of platelet aggregation reach a plateau at “80% receptor occupancy,” a value achieved in many clinical trials, it is not yet known whether the 80% receptor occupancy level optimizes the antithrombotic efficacy of this class of drugs. Indeed, the GpIIb/IIIa receptor blockade necessary to produce an antithrombotic effect depends on the thrombotic challenge, which is difficult to predict (46).

Because of the technical constraints of receptor-binding assays and standard turbidimetric platelet aggregometry, these studies were limited to only a small number of patients. The development of a rapid, whole-blood, point-of-care (POC) platelet function assay, the Ultegra RPFa (Accumetrics), with results that correlate well with turbidimetric aggregometry and receptor-binding assays (24), led to studies on a larger population, thus allowing correlation with clinical outcomes. In the GOLD study, those patients in the lowest quartile of platelet function inhibition (<95%) at 10 min after the Gp IIb/IIIa antagonist bolus had a significantly higher incidence of major coronary events compared with the others (Fig. 6) (46). At 8 h after the bolus dose, patients with <70% platelet function inhibition experienced three times the event rate of those with >70% inhibition (25 vs 8.1%;  $p < 0.009$ ). By multivariate logistic modeling, when evaluated individually, the levels of inhibition achieved at 10 min and at 8 h after the Gp IIb/IIIa inhibitor bolus were found to correlate with clinical outcomes. The prospective TEAM study showed that 50% of the patients were undertreated when receiving the recommended dose of IIb/IIIa-RA and needed an additional bolus to reach 90% inhibition of platelet receptors (Fig. 7) (47).

GpIIb/IIIa antagonists are expensive drugs that require iv bolus plus infusion delivery. Of interest is the PEACE study, which assessed platelet activation with flow cytometry in 32 non-ST-elevation myocardial infarction (NSTEMI) patients to establish whether



**Fig. 7.** Results of TEAM study. Platelet receptor blockade was assessed 10 min after IIb/IIIa-RA bolus infusion and before elective PCI. An additional bolus of IIb/IIIa-RA was given if 90% inhibition of platelet function was not obtained (47).

eptifibatide provided a significant antiplatelet effect above that of aspirin and clopidogrel (48). Following *ex vivo* stimulation, activated GpIIb/IIIa receptor expression and fibrinogen binding were reduced following clopidogrel and markedly further reduced with eptifibatide (all  $p < 0.0001$ ). Total GpIIb/IIIa and P-selectin expression were also significantly reduced following clopidogrel, indicating that eptifibatide provides potent antiplatelet activity above that of aspirin and clopidogrel.

The RPFa, a bedside measure of platelet function, is effective and reliable and correlates with clinical outcomes. This convenient technology represents a significant advance compared with the prior “gold standard” of cumbersome platelet aggregometry for monitoring GpIIb/IIIa-RA and allows immediate dose adjustment of these expensive therapies. Whether the RPFa should be implemented in routine care warrants additional randomized studies. Indeed, whether titrating therapy to a specific level of inhibition will decrease risk remains unknown.

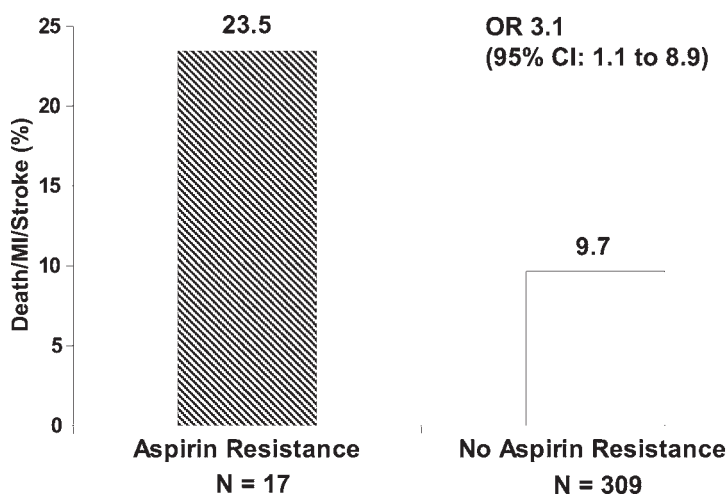
### *Tracking Aspirin Resistance*

Aspirin is an effective antiplatelet agent for preventing important clinical complications of atherothrombosis (49). However, it fails to prevent more than four-fifths of recurrent serious vascular events among high-risk patients. It is important to identify patients who may have the appropriate platelet response to a given therapy but have recurrent events mediated by nonplatelet factors (failure to therapy) and those in whom the agent does not achieve its pharmacological effect (resistance). In fact, the key clinical question is: What role does resistance to an agent play in failure of therapy? Platelet monitoring is a key issue for answering this question.

#### **DEFINING ASPIRIN RESISTANCE**

Aspirin resistance has been defined most commonly by a reduced or absent inhibition of platelet aggregation, measured typically using light transmittance. Although there is now clear evidence of a link between aspirin resistance and clinical events, the prevalence of resistance varies according to platelet function methodology (50). Indeed, laboratory





**Fig. 8.** Excess of serious vascular events among aspirin-resistant patients compared with nonaspirin-resistant patients (53). OR, odds ratio.

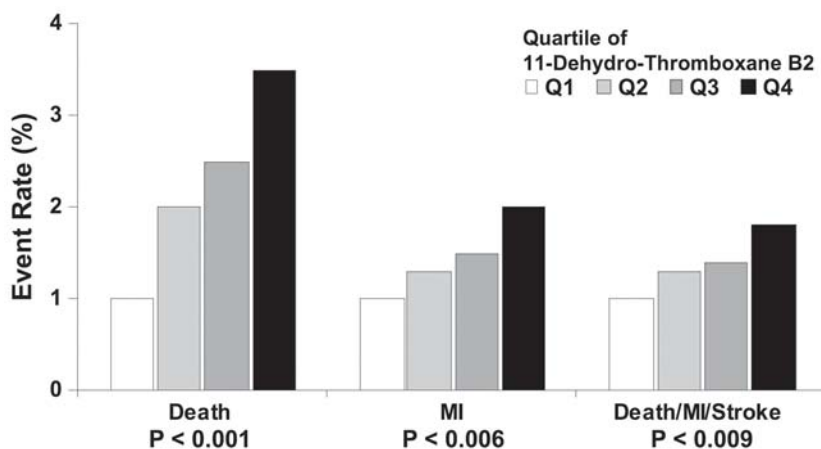
definitions of aspirin resistance have varied according to the platelet function tests and platelet agonists used. As a consequence, the range of aspirin resistance that is quoted varies widely, from 5 to 40% (50). Platelet aggregation by light transmittance (optical aggregometry) in PRP is the gold standard method, with aspirin resistance often defined as mean aggregation  $\oplus$ 70% in response to 10  $\mu$ M ADP. However, it is difficult to assess which aggregation technique is the most accurate and valid measure of aspirin resistance without direct comparisons of their clinical relevance.

#### ASPIRIN RESISTANCE AND OUTCOMES

In patients with a prior stroke, those with aspirin resistance were 89% more likely to have a recurrent cerebrovascular event within 2 yr than were responders (51). Similar results were seen in patients after peripheral intervention, with an increase in arterial reocclusion among aspirin responders (52). More recently, three separate and well-conducted studies support an association between aspirin resistance and worse clinical outcome in patients with stable coronary artery disease (53–55).

In 2001, Gum et al. (18) reported that 5.5% of a small series of patients with a prior history of coronary or cerebral vascular disease were aspirin resistant. Aspirin resistance was defined as the failure of 325 mg/d of aspirin given for a minimum of 7 d before testing to suppress agonist-induced platelet aggregation, as measured by optical platelet aggregometry. The cutoff for the diagnosis of aspirin resistance was derived from screening 40 in-house healthy samples, but details as to how this cutoff was chosen were not provided. After 2 yr of follow-up, they reported that aspirin resistance was associated with a fourfold excess of serious vascular events, which was independent of age, gender, and conventional vascular risk factors (Fig. 8). In addition, this failure to achieve an anticipated effect of aspirin on a laboratory measure was found to be an independent predictor of future risk of serious vascular events.

Baseline aspirin responsiveness in this same patient population was also determined with the PFA-100 (18). The  $\kappa$  statistic between these two methods was 0.1 (95% confidence interval: 0.045–0.246), indicating a poor correlation between optical platelet aggregation and the PFA-100 in detection of aspirin resistance. There was a nonsignificant correlation



**Fig. 9.** Association between quartiles of 11-dehydro TXB<sub>2</sub> and outcomes after adjustment for baseline differences between cases and control subjects (*p* value is for difference between upper and lower quartiles) (54).

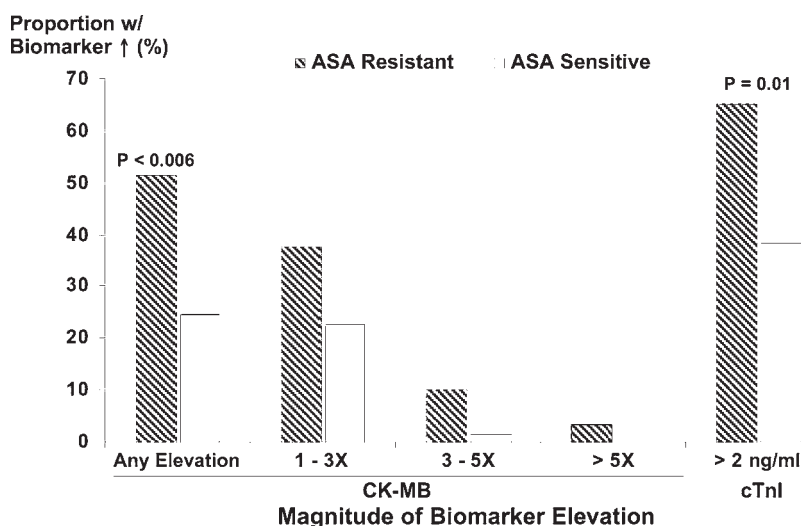
between long-term outcomes and baseline aspirin responsiveness as determined by the PFA-100 (12.9% events in aspirin sensitive vs 15.1% in aspirin resistant;  $p < 0.4$ ). This suggests that the PFA-100 is not as specific compared with optical platelet aggregation for determining clinically relevant aspirin resistance (53,56). However, a real association may have been missed by the small number of events. In addition, the PFA-100 does not provide a specific measure of the antiplatelet effects of aspirin and may lack sensitivity for measuring the antiplatelet effects of low-dose aspirin (57).

Using patients who were taking aspirin from the Heart Outcomes Prevention Evaluation study, Eikelboom et al. (54) measured baseline urinary TXB<sub>2</sub>, which serves as a marker of thromboxane generation. Levels were compared between those patients taking aspirin who sustained an ischemic event and those who did not sustain an event. Those in the highest quartile of urinary thromboxane generation had twice the risk of an MI than those in the lowest quartile (Fig. 9). The researchers concluded that the incomplete suppression of thromboxane generation by aspirin—i.e., aspirin resistance—was the cause of the increased risk. However, because the concentration of TXB<sub>2</sub> in the urine reflects both platelet and nonplatelet sources of thromboxane generation, this analysis may not provide a specific measure of the antiplatelet effects of aspirin. Furthermore, the predictive value of TXB<sub>2</sub> in an individual patient has not been demonstrated and requires further evaluation.

More recently, using the RPFA assay, Chen et al. (55) categorized patients as either aspirin sensitive or aspirin resistant and measured the incidence of myonecrosis after elective percutaneous coronary intervention (PCI) (Fig. 10). By this classification, 19.2% of patients were aspirin resistant. Patients determined to be aspirin resistant were more likely to have periprocedural myonecrosis, highlighting that if a patient about to undergo PCI is determined to be aspirin resistant, some attempt should be made to intensify antiplatelet therapy.

## REMAINING ISSUES

There are several issues regarding aspirin resistance that still need to be addressed. First, existing laboratory measurements of the antiplatelet effects of aspirin are limited. Researchers need to determine which measure is the most relevant. Second, a standardized



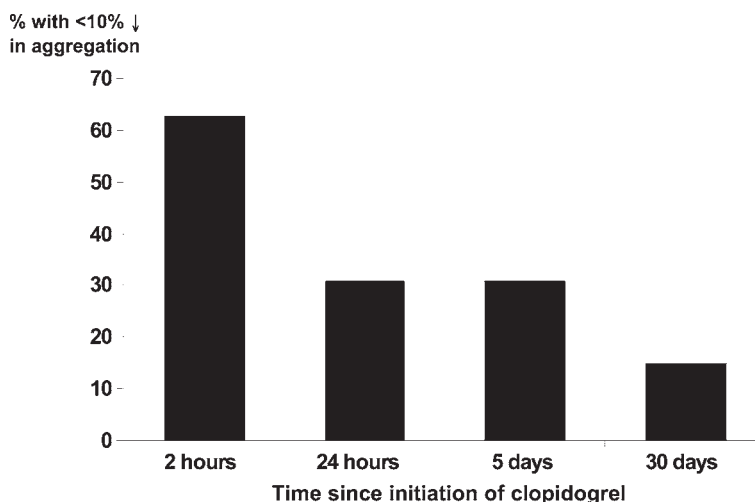
**Fig. 10.** Incidence and magnitude of creatine kinase-myocardial band (CK-MB) and cardiac troponin I (cTnI) elevation in aspirin-resistant and aspirin-sensitive patients after PCI (55). ASA, aspirin.

definition of aspirin resistance should be developed. Not only should it incorporate an absent or attenuated laboratory response to a therapeutic antiplatelet dose of aspirin in a compliant patient that correlates significantly and independently with its effects in preventing atherothrombotic vascular events, but it should also require a specific, accurate, and reproducible laboratory measure of the antiplatelet effects of aspirin, the results of which can be generalized to other laboratories and patients. None of the currently available laboratory tests of the antiplatelet effects of aspirin has yet been demonstrated to meet these criteria adequately. Third, even if aspirin resistance could be defined and reliably diagnosed by laboratory testing, screening for aspirin resistance (in asymptomatic individuals and in symptomatic patients who experience a thrombotic complication despite aspirin therapy) could still be recommended if the results of screening (positive and negative) influenced clinical management (such as optimizing the prediction of risk of serious vascular event) or led to treatments that improved patient outcome in a cost-effective manner.

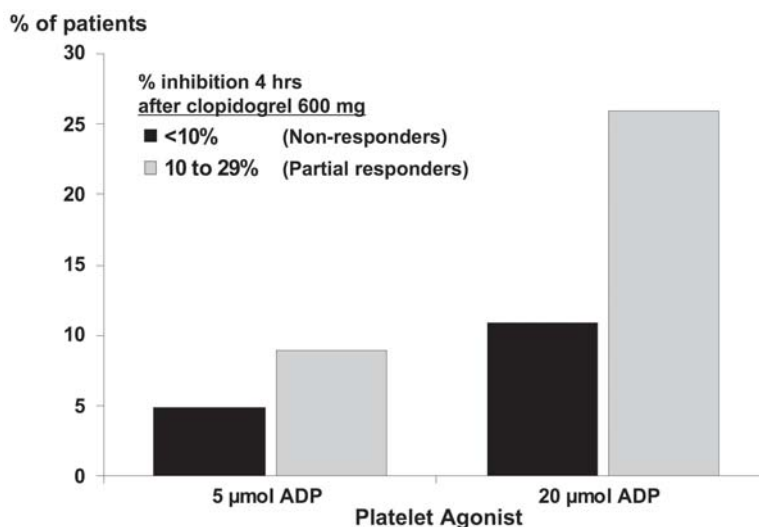
### **Monitoring Clopidogrel Therapy**

There is a dose- and time-dependent variability in response to clopidogrel as measured by optical platelet aggregometry in response to ADP (Figs. 11 and 12) (58–61). Of interest is that although not designed to evaluate clinical outcomes, an intriguing finding in a study by Muller et al. (59) was that 2 patients (of 105 tested) developed subacute stent thrombosis, and both met the definition of clopidogrel nonresponse. An additional report correlated anginal class to platelet inhibition and found that patients with higher anginal class on presentation had less inhibition of platelet aggregation after loading with 450 mg of clopidogrel (62).

More recently, the laboratory measure of nonresponse to clopidogrel was correlated to clinical outcomes in patients who underwent primary PCI for STEMI (63). In those who received stents ( $n = 60$ ), a loading dose of 300 mg of clopidogrel was given immediately after PCI and 75 mg daily for 3 mo. Platelet function tests were performed with turbidimetric analysis after stimulation with ADP (5  $\mu\text{mol/L}$ ) and epinephrine (10  $\mu\text{mol/L}$ ), as



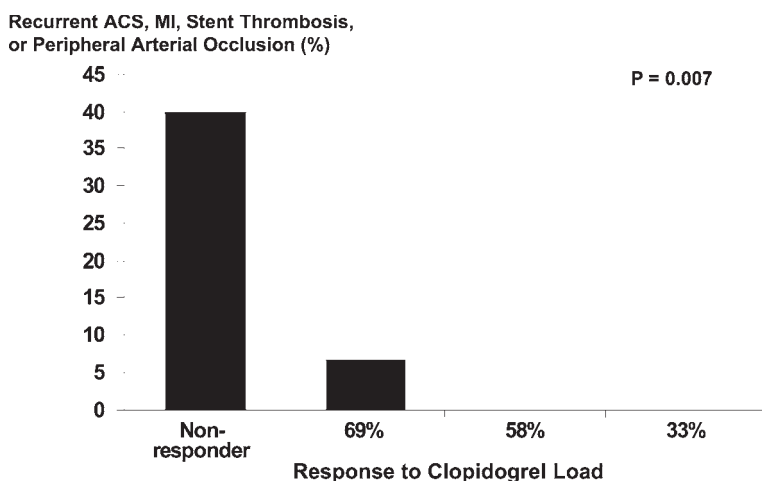
**Fig. 11.** Monitoring of platelet aggregation in 96 patients undergoing elective coronary stenting before and after loading dose of 300 mg of clopidogrel followed by 75 mg daily. Clopidogrel resistance was defined as baseline aggregation (%) minus posttreatment aggregation (%)  $\leq 10\%$  in response to 5  $\mu\text{mol/L}$  of ADP (58).



**Fig. 12.** Evaluation of nonresponders ( $<10\%$  reduction in platelet aggregation to ADP) and semi-responders (10–29% reduction) 4 h after 600-mg clopidogrel load (59).

well as with separate assays of platelet function using a CPA. Patients were divided into quartiles of inhibition of platelet aggregation (platelet aggregation compared with baseline platelet aggregation), with the first quartile considered nonresponders (d 6 aggregation of  $103 \pm 8\%$  compared with baseline). Although the study population was small, the data strongly suggest that there is individual variability in response to clopidogrel in the setting of PCI after STEMI and more broadly that clopidogrel resistance may be a marker for increased risk of recurrent cardiovascular events (Fig. 13).

Finally, the ALBION study will provide evidence for the correct loading dose of clopidogrel. This open-label study compares three regimens of loading dose (300, 600, and



**Fig. 13.** Event rates according to level of response to loading dose of clopidogrel in patients undergoing primary PCI for STEMI (63).

900 mg) in 70 patients with NSTEMI and treated medically for 24 h before undergoing PCI (64). The primary end points are biological end points based on platelet monitoring (optical aggregometry, bedside testing, platelet membrane biomarkers).

The same questions as for aspirin resistance are arising for long-term clopidogrel therapy:

1. Should patients with ACS or those undergoing PCI routinely have platelet function measured? If so, how should it be measured?
2. What should be considered the appropriate definition of clopidogrel resistance?
3. What therapeutic maneuvers should clinicians undertake when they encounter a patient with clopidogrel resistance?
4. Are there actions that can be taken prospectively to avoid the problem of resistance?

Correlations between clinical outcomes and biological status need to be confirmed with larger data sets. Finally, before these measurements become feasible for clinical use for risk stratification, easily performed and reproducible techniques to measure platelet aggregation with standardized definitions of response that correlate with clinical outcomes must be developed.

## CONCLUSION

The objectives of platelet monitoring for clinical cardiology are to evaluate new anti-thrombotic therapies and to track abnormal response to available antiplatelet agents. Indeed, as more is learned about the variable response to antiplatelet drugs, researchers may come to think of antiplatelet agents as they do of antibiotics, with the ultimate goal of tailoring therapy when resistance is observed in the laboratory. However, there is currently no study that permits researchers to move antiplatelet therapy resistance from a laboratory curiosity into mainstream medical practice. Indeed, there are no data that establish a cause-and-effect relationship or allow the establishment of an algorithm for treatment in response to measured platelet function inhibition.

## REFERENCES

1. Braunwald E, Antman EM, Califf RM, et al. ACC/AHA Guideline Update for the Management of Patients with Unstable Angina and Non-ST-Segment Elevation Myocardial Infarction—2002: Summary Article: A Report of the American College of Cardiology/American Heart Association Task Force on Practice Guidelines (Committee on the Management of Patients with Unstable Angina). *Circulation* 2002;106:1893–1900.
2. Michelson AD. How platelets work: platelet function and dysfunction. *J Thromb Thrombolysis* 2004;16:7–12.
3. Woulfe D, Yang J, Prevost N, O'Brien PJ, Brass LF. Signal transduction during the initiation, extension, and perpetuation of platelet plug formation. In: Michelson AD, ed. *Platelets*. Academic/Elsevier Science, New York, 2002, pp. 197–213.
4. Packham MA, Rand ML, Kinlough-Rathbone RL. Aggregation. In: Gresele P, Page CP, Fuster V, Vermynen J, eds. *Platelets in Thrombotic and Non-Thrombotic Disorders*. Cambridge University Press; Cambridge, UK, 2002, pp. 338–356.
5. Tsuji S, Sugimoto M, Miyata S, et al. Real-time analysis of mural thrombus formation in various platelet aggregation disorders: distinct shear-dependent roles of platelet receptors and adhesive proteins under flow. *Blood* 1999;94:968–975.
6. Nieuwland R, Sturk A. Platelet-derived microparticles. In: Michelson AD, ed. *Platelets*. Academic/Elsevier Science, New York, 2002, pp. 255–265.
7. Bouchard BA, Butenas S, Mann KG, Tracy PB. Interactions between platelets and the coagulation system. In: Michelson AD, ed. *Platelets*. Academic/Elsevier Science New York, 2002, pp. 229–253.
8. Du X, Ginsberg MH. Integrin  $\alpha$ IIB $\beta$ 3 and platelet function. *Thromb Haemost* 1997;78:96–100.
9. Zwaal RFA, Comfurius P, Bevers EM. Lipid-protein interactions in blood coagulation. *Biochim Biophys Acta* 1998;1376:433–453.
10. Coughlin SR. Protease activated receptors and platelet function. *Thromb Haemost* 1999;82:353–356.
11. Patrignani P, Sciuilli G. Amplification loops: thromboxane generation. In: Gresele P, Page CP, Fuster V, Vermynen J, eds. *Platelets in Thrombotic and Non-Thrombotic Disorders*. Cambridge University Press, Cambridge, UK, 2002, pp. 369–380.
12. Thiagarajan P, Wu KK. In vitro assays for evaluating platelet function. In: Gresele P, Page CP, Fuster V, Vermynen J, eds. *Platelets in Thrombotic and Non-Thrombotic Disorders*. Cambridge University Press, Cambridge, UK, 2002, pp. 459–470.
13. Rodgers RP, Levin J. A critical reappraisal of the bleeding time. *Semin Thromb Hemost* 1990;16:1–20.
14. Kundu SK, Heilmann EJ, Sio R, et al. Description of an in vitro platelet function analyzer PFA-100TM. *Semin Thromb Hemost* 1995;21(Suppl 2):106–112.
15. Jilma B. Platelet function analyzer (PFA-100): a tool to quantify congenital or acquired platelet dysfunction. *J Lab Clin Med* 2001;138:152–163.
16. Fressinaud E, Veyradier A, Truchaud F, et al. Screening for von Willebrand disease with a new analyzer using high shear stress: a study of 60 cases. *Blood* 1998;91:1325–1331.
17. Hezard N, Metz D, Nazeyrollas P, et al. Use of the PFA-100TM apparatus to assess platelet function in patients undergoing PTCA during and after infusion of cE3 Fab in the presence of other antiplatelet agents. *Thromb Haemost* 2000;83:540–544.
18. Gum PA, Kottke-Marchant K, Poggio ED, et al. Profile and prevalence of aspirin resistance in patients with cardiovascular disease. *Am J Cardiol* 2001;88:230–235.
19. Jarvis GE. Platelet aggregation: turbidimetric measurements. *Methods Mol Biol* 2004;272:65–76.
20. White MM, Jennings LK. *Platelet Protocols: Research and Clinical Laboratory Procedures*. Academic, San Diego, 1999.
21. Collier BS. Monitoring of platelet GP IIb/IIIa antagonist therapy. *Circulation* 1997;96:3828–3832.
22. Ingerman-Wojenski C, Smith JB, Silver MJ. Evaluation of electrical aggregometry: comparison with optical aggregometry, secretion of ATP, and accumulation of radiolabeled platelets. *J Lab Clin Med* 1983;101:44–52.
23. Steinhubl SR, Kereiakes DJ. Ultegra rapid platelet function analyzer. In: Michelson A, ed. *Platelets*. Academic, San Diego, 2002, pp. 317–323.
24. Smith JW, Steinhubl SR, Lincoff AM, et al. The rapid platelet function assay: an automated and quantitative cartridge-based method. *Circulation* 1999;99:620–625.
25. Kereiakes DJ, Mueller M, Howard W, et al. Efficacy of abciximab induced platelet blockade using a rapid point of care assay. *J Thromb Thrombolysis* 1999;7:265–275.

26. Steinhubl SR, Talley JB, Braden GA, et al. Point-of-care measured platelet inhibition correlates with a reduced risk of an adverse cardiac event after percutaneous coronary intervention: results of the GOLD (AU-assessing Ultegra) multi-center study. *Circulation* 2001;103:2572–2578.
27. Kulkarni S, Nesbitt WS, Dopheide SM, et al. Techniques to examine platelet adhesive interactions under flow. *Methods Mol Biol* 2004;272:165–186.
28. Varon D, Savion N. Cone and plate(let) analyzer. In: Michelson A, ed. *Platelets*. Academic, San Diego, 2002, pp. 337–345.
29. Goodall AH, Appleby J. Flow-cytometric analysis of platelet-membrane glycoprotein expression and platelet activation. *Methods Mol Biol* 2004;272:225–254.
30. Michelson AD, Barnard MR, Krueger LA, Frelinger III AL, Furman MI. Flow cytometry. In: Michelson AD, ed. *Platelets*. Academic, San Diego, 2002, pp. 297–315.
31. Dachary-Prigent J, Freyssinet J-M, Pasquet J-M, Carron JC, Nurden AT. Annexin V as a probe of aminophospholipid exposure and platelet membrane vesiculation: a flow cytometry study showing a role for free sulfhydryl groups. *Blood* 1993;81:2554–2565.
32. Schultheiss HP, Tschoepe D, Esser J, et al. Large platelets continue to circulate in an activated state after myocardial infarction. *Eur J Clin Invest* 1994;24:243–247.
33. Furman MI, Benoit SE, Barnard MR, et al. Increased platelet reactivity and circulating monocyte-platelet aggregates in patients with stable coronary artery disease. *J Am Coll Cardiol* 1998;31:325–328.
34. Scharf RE, Tomer A, Marzec UM, et al. Activation of platelets in blood perfusing angioplasty-damaged coronary arteries: flow cytometric detection. *Arterioscl Thromb* 1992;12:475–487.
35. Montalescot G, Bal-dit-Solier C, Chibedit D, et al. Comparison of effects on markers of blood cell activation of enoxaparin, dalteparin, and unfractionated heparin in patients with unstable angina pectoris or non-ST-segment elevation acute myocardial infarction (the ARMADA study). *Am J Cardiol* 2003;91:925–930.
36. Carr ME. Development of platelet contractile force as a research and clinical measure of platelet function. *Cell Biochem Biophys* 2003;38:55–78.
37. Collet JP, Montalescot G, Lesty C, et al. Disaggregation of in vitro pre-formed platelet-rich clots by abciximab increases fibrin exposure and promotes fibrinolysis. *Arterioscl Thromb Vasc Biol* 2001;21:142–148.
38. Collet JPH, Montalescot G, Lesty C, Weisel JW. A structural and dynamic investigation of the facilitating effect of glycoprotein IIb/IIIa inhibitors in dissolving platelet-rich clots. *Circ Res* 2002;90:428–434.
39. Collet JPH, Montalescot G, Lesty C, et al. Effects of abciximab on the architecture of platelet-rich clot in patients with acute myocardial infarction undergoing primary coronary intervention. *Circulation* 2001;103:2328–2331.
40. Bevers EM, Comfurios P, Reutelingsperger CPM, Zwaal RFA. Platelet procoagulant activity and its measurement. In: Watson SP, Authi KS, eds. *Platelets: A Practical Approach*. Oxford University Press, New York, 1996, pp. 319–340.
41. Wagner CL, Mascelli MA, Neblock DS, et al. Analysis of GPIIb/IIIa receptor number by quantification of 7E3 binding to human platelets. *Blood* 1996;88:907–914.
42. Phillips DR, Teng W, Arfsten A, et al. Effect of Ca<sup>2+</sup> on GP IIb/IIIa interactions with integrilin: enhanced GP IIb/IIIa binding and inhibition of platelet aggregation by reduction in the concentration of ionized calcium in plasma anticoagulated with citrate. *Circulation* 1997;96:1488–1494.
43. The IMPACT-II investigators. Randomized placebo controlled trial of effect of eptifibatide on complications of percutaneous coronary intervention: IMPACT-II. *Lancet* 1997;349:1422–1428.
44. The PURSUIT Trial Investigators. Inhibition of platelet glycoprotein IIb/IIIa with eptifibatide in patients with acute coronary syndromes. *N Engl J Med* 1998;339:436–443.
45. Tcheng JE, Ellis SG, George BS, et al. Pharmacodynamics of chimeric glycoprotein IIb/IIIa integrin antiplatelet antibody Fab 7E3 in high-risk coronary angioplasty. *Circulation* 1994;90:1757–1764.
46. Steinhubl SR, Talley J, Braden G, et al. Point-of-care measured platelet inhibition correlates with a reduced risk of an adverse cardiac event following percutaneous coronary intervention: results of the GOLD (AU-assessing Ultegra) multicenter study. *Circulation* 2001;103:2572–2578.
47. Kini AS, Richard M, Suleman J, et al. Effectiveness of tirofiban, eptifibatide, and abciximab in minimizing myocardial necrosis during percutaneous coronary intervention (TEAM pilot study). *Am J Cardiol* 2002;90:999–1002.
48. Dalby M, Montalescot G, Bal dit Sollier C, et al. Eptifibatide provides additional platelet inhibition in non-ST-elevation myocardial infarction patients already treated with aspirin and clopidogrel: results of the platelet activity extinction in non-Q-wave myocardial infarction with aspirin, clopidogrel, and eptifibatide (PEACE study). *J Am Coll Cardiol* 2004;43:162–168.

49. Antiplatelet trialists' collaboration. Collaborative meta-analysis of randomised trials of antiplatelet therapy for prevention of death, myocardial infarction, and stroke in high risk patients. *BMJ* 2002;324:71–86.
50. McKee SA, Sane DC, Deliargyris EN. Aspirin resistance in cardiovascular disease: a review of prevalence, mechanisms, and clinical significance. *Thromb Haemost* 2002;88:711–715.
51. Grottemeyer KH, Scharafinski HW, Hussted JW. Two-year follow-up of aspirin responder and aspirin non responder: a pilot study including 180 post-stroke patients. *Thromb Res* 1993;71:397–403.
52. Mueller MR, Salat A, Stangl P, et al. Variable platelet response to low-dose ASA and the risk of limb deterioration in patients submitted to peripheral arterial angioplasty. *Thromb Haemost* 1997;78:1003–1007.
53. Gum PA, Kottke-Marchant K, Welsh PA, White J, Topol EJ. A prospective, blinded determination of the natural history of aspirin resistance among stable patients with cardiovascular disease. *J Am Coll Cardiol* 2003;41:961–965.
54. Eikelboom JW, Hirsh J, Weitz JI, et al. Aspirin-resistant thromboxane biosynthesis and the risk of myocardial infarction, stroke, or cardiovascular death in patients at high risk for cardiovascular events. *Circulation* 2002;105:1650–1655.
55. Chen WH, Lee PY, Ng W, Tse HF, Lau CP. Aspirin resistance is associated with a high incidence of myonecrosis after non-urgent percutaneous coronary intervention despite clopidogrel pretreatment. *J Am Coll Cardiol* 2004;43:1122–1126.
56. Steinhubl SR, Varinasi JS, Goldberg L. Determination of the natural history of aspirin resistance among stable patients with cardiovascular disease. *J Am Coll Cardiol* 2004;42:1336, 1337.
57. Feuring M, Haseroth K, Janson CP, et al. Inhibition of platelet aggregation after intake of acetylsalicylic acid detected by a platelet function analyzer (PFA-100). *Int J Clin Pharmacol Ther* 1999;37:584–588.
58. Gurbel PA, Bliden KP, Hiatt BL, et al. Clopidogrel for coronary stenting: response variability, drug resistance, and the effect of pretreatment platelet reactivity. *Circulation* 2003;107:2908–2913.
59. Muller I, Besta F, Schulz C, et al. Prevalence of clopidogrel nonresponders among patients with stable angina pectoris scheduled for elective coronary stent placement. *Thromb Haemost* 2003;89:783–787.
60. Jaremo P, Lindahl TL, Fransson SG, et al. Individual variations of platelet inhibition after loading doses of clopidogrel. *J Intern Med* 2002;252:233–238.
61. Gurbel PA, Bliden KP. Durability of platelet inhibition by clopidogrel. *Am J Cardiol* 2003;91:1123–1125.
62. Soffer D, Moussa I, Harjai KJ, et al. Impact of angina class on inhibition of platelet aggregation following clopidogrel loading in patients undergoing coronary intervention: do we need more aggressive dosing regimens in unstable angina? *Catheter Cardiovasc Intervent* 2003;59:21–25.
63. Matetzky S, Shenkman B, Guetta V, et al. Clopidogrel resistance is associated with increased risk of recurrent atherothrombotic events in patients with acute myocardial infarction. *Circulation* 2004;109:3171–3175.
64. Heeschen C, Dimmeler S, Hamm CW, et al. Soluble CD40 ligand in acute coronary syndromes. *N Engl J Med* 2003;348:1104–1111.





# 28

---

## Monocyte–Platelet Aggregates in Patients With Ischemic Heart Disease

---

*Matthew D. Linden, PhD  
and Mark I. Furman, MD*

### CONTENTS

INTRODUCTION  
MOLECULAR BASIS OF MONOCYTE–PLATELET INTERACTION  
MONOCYTE–PLATELET AGGREGATES AS A MARKER OF CAD  
LABORATORY DETECTION OF MONOCYTE–PLATELET AGGREGATION  
PATHOPHYSIOLOGY OF MONOCYTE–PLATELET AGGREGATES IN CAD  
CONCLUSION  
REFERENCES

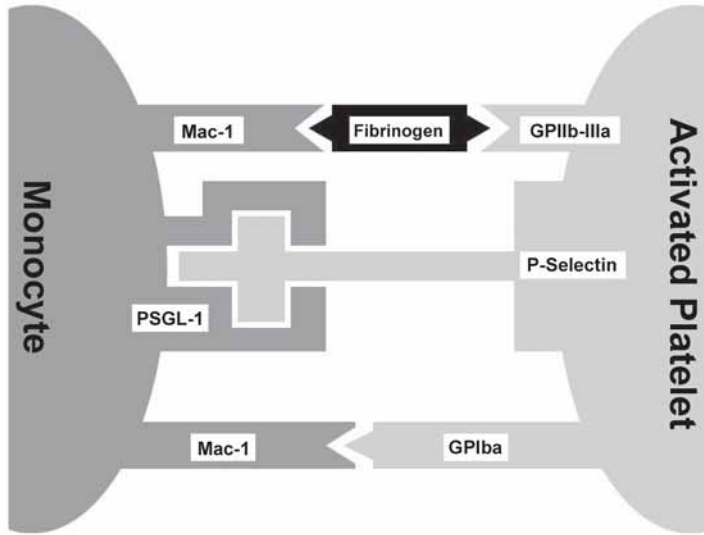
---

### SUMMARY

Platelets are a central cellular interface of the thrombotic and inflammatory processes of coronary atherosclerosis and modulate this interface by binding to leukocytes and altering their function. In addition, platelet activation; formation of leukocyte–platelet aggregates (monocyte–platelet aggregates and neutrophil–platelet aggregates); and platelet secretion of inflammatory modulators that affect leukocyte function, such as CD40 ligand, are associated with progression of disease across the entire spectrum of atherothrombosis. Monocyte–platelet aggregates are elevated in stable coronary artery disease and further elevate with plaque rupture, characteristic of percutaneous coronary intervention, acute coronary syndromes, and myocardial infarction. Through this interaction, activated platelets may contribute to the pathogenesis of ischemic heart disease by localizing and activating monocytes to the site of the atherosclerotic lesion. These heterotypic aggregates have potential for a number of clinical applications, including measurement as an early marker for plaque rupture, evaluation of the efficacy of anti-platelet therapy, and as a potential target for therapeutic intervention. Additional investigations evaluating these applications as well as the relationship between monocyte–platelet aggregates and outcome are needed.

**Key Words:** Unstable angina; acute coronary syndrome; platelets; monocytes.

From: *Contemporary Cardiology:  
Cardiovascular Biomarkers: Pathophysiology and Disease Management*  
Edited by: David A. Morrow © Humana Press Inc., Totowa, NJ



**Fig. 1.** Molecular basis of monocyte–platelet aggregates. Activated platelets express P-selectin on the cell surface. P-selectin binds to PSGL-1 constitutively expressed on monocyte. This initial adhesion causes activation of the monocyte, resulting in a conformational change and increased expression of Mac-1. Binding of Mac-1 to GPIIb-IIIa via fibrinogen, and directly to GPIb $\alpha$  on the platelet, stabilizes the monocyte–platelet aggregate.

## INTRODUCTION

Platelets are a central cellular interface of the thrombotic and inflammatory processes of coronary atherosclerosis (1) and modulate this interface by binding to leukocytes and altering their function (2). Correspondingly, platelets play a pivotal role in recruitment of monocytes and neutrophils to sites of vascular injury and, thus, to the atherosclerotic plaque (3). Platelet activation; formation of leukocyte–platelet aggregates (monocyte–platelet aggregates and neutrophil–platelet aggregates); and platelet secretion of inflammatory modulators that affect leukocyte function, such as CD40 ligand (CD40L), are associated with the development of atherosclerosis (4–6), stable coronary artery disease (CAD) (7), unstable angina (8), myocardial infarction (MI) (9,10), and events following percutaneous coronary intervention (PCI) (10), with a greater magnitude in patients experiencing late clinical events (11).

## MOLECULAR BASIS OF MONOCYTE–PLATELET INTERACTION

In vivo platelet activation results in a series of changes in platelet structure and biochemistry. P-selectin (CD62P) is a component of the  $\alpha$ -granule membrane and is not normally expressed on the surface of platelets (2,12–14). Upon platelet activation,  $\alpha$ -granule soluble contents are released and P-selectin is exposed on the platelet surface (2,13,14). In vitro, the activation-dependent increase in platelet surface P-selectin is not reversible over time (15,16). However, in vivo, circulating degranulated platelets rapidly lose their surface P-selectin, yet continue to circulate and function (17).

Surface expression of P-selectin on platelets mediates the initial adhesion of activated platelets to monocytes and neutrophils via P-selectin glycoprotein ligand 1 (PSGL-1), which is constitutively expressed on the surface of these leukocytes (Fig. 1) (2,18,19).

Following initial tethering to activated platelets via P-selectin/PSGL-1 interaction, leukocyte activation occurs through signaling via PSGL-1 and platelet-secreted chemokines and lipid mediators (20–25). This response in turn causes activation and upregulation of the Mac-1 integrin ( $\alpha_M\beta_2$ , CD11b/CD18) on the monocyte surface, allowing firm adhesion to platelets via bridging fibrinogen bound to the activated glycoprotein IIb-IIIa integrin ( $\alpha_{IIb}\beta_3$ , CD61/CD41) (23), and via direct interaction with GPIIb/IIIa ( $\alpha_{IIb}\beta_3$ ) (26) on the platelet surface. Other adhesion molecules such as LFA-1 on the monocytes interacting with intracellular adhesion molecule-2 on platelets may play a role in stabilizing monocyte–platelet aggregates (27). However, P-selectin/PSGL-1 interaction is first required before these stable secondary adhesions may take place.

Studies of biotinylated autologous infused platelets in baboons have demonstrated that platelets degranulated by thrombin very rapidly (within 1 min) form circulating aggregates with monocytes and neutrophils *in vivo* (10). The half-life of detectable circulating monocyte–platelet aggregates (approx 30 min) is longer than both the half-life of neutrophil–platelet aggregates (approx 5 min) and the rapid loss of platelet surface P-selectin *in vivo* (10).

### MONOCYTE–PLATELET AGGREGATES AS A MARKER OF CAD

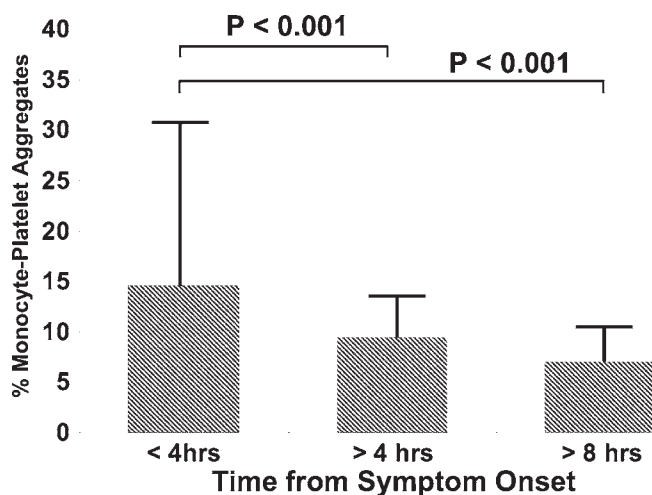
Patients with stable CAD have elevated P-selectin expressed on the platelet surface and both increased circulating monocyte–platelet aggregates and an increased propensity to form monocyte–platelet aggregates with platelet stimulation (7). This phenomenon reflects a process of ongoing platelet degranulation and an as yet poorly defined intracellular platelet environment that makes the platelets more responsive to agonist stimulation. The increase in monocyte–platelet aggregate formation may simply reflect more frequent platelet degranulation in patients with stable CAD.

Monocyte–platelet aggregates are increased to higher concentrations in unstable angina and MI (10,28). Furthermore, following plaque rupture associated with PCI, the number of circulating monocyte–platelet aggregates rapidly increases (10), whereas P-selectin expression does not. Therefore, monocyte–platelet aggregates are a more sensitive marker of *in vivo* platelet activation in the setting of PCI than the previous “gold standard” of platelet surface P-selectin.

Standard diagnostic markers of acute MI (AMI), such as the MB isoform of creatine kinase (CK-MB) and cardiac troponin, reflect the onset of myonecrosis rather than the early underlying etiological processes of plaque rupture, and platelet activation. Such markers of myonecrosis do not appear in the peripheral circulation until at least 4 hours after the onset of ischemic injury. However, monocyte–platelet aggregates are elevated <4 h following the onset of symptoms of AMI (Fig. 2) (9) and thus serve as an early marker of AMI, potentially offering the opportunity to facilitate early treatment to reduce morbidity and mortality.

### LABORATORY DETECTION OF MONOCYTE–PLATELET AGGREGATION

Monocytes are readily identifiable by whole-blood flow cytometry based on light-scatter properties and by using a monocyte-specific monoclonal antibody (e.g., the lipopolysaccharide receptor CD14) (7,9,29–31). Leukocyte–platelet aggregates may be identified by the detection of platelet-specific markers (e.g., CD41, CD61, or CD42b) (29,31) on



**Fig. 2.** Monocyte–platelet aggregates are an early marker of MI. In patients presenting with MI, monocyte–platelet aggregates were highest within 4 h of onset. (Adapted with permission from ref. 9.)

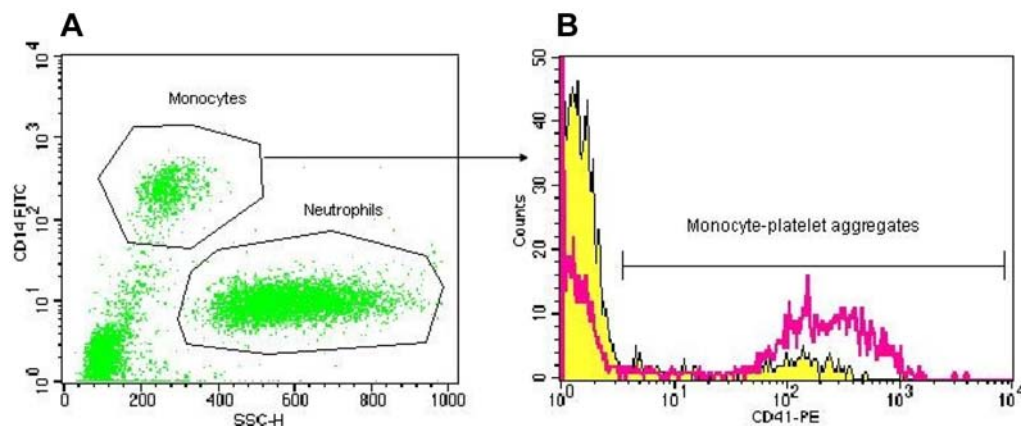
monocytes. Circulating monocyte–platelet aggregates may be expressed as a proportion of overall circulating monocytes or, using beads, absolute counts. [Figure 3](#) demonstrates how monocyte–platelet aggregates are identified using flow cytometry.

### PATHOPHYSIOLOGY OF MONOCYTE–PLATELET AGGREGATES IN CAD

The exact physiological significance of monocyte–platelet aggregation in CAD is unknown, but it may represent targeting of both cell types to appropriate inflammatory or hemostatic sites (32). For example, platelets have been shown to supply cholesterol to monocytes, which may then mature into lipid-laden macrophages (33). P-selectin on the surface of activated platelets induces expression of tissue factor on monocytes (34). The binding of P-selectin to monocytes in the area of vascular injury may be an initiator of thrombosis (34). Therefore, P-selectin-mediated adhesion to leukocytes is important in promoting fibrin deposition within a growing thrombus (3). Adhesion of activated platelets to monocytes can regulate monocyte chemokine synthesis to affect inflammatory processes (24) and induce upregulation and activation of monocyte adhesion receptors such as Mac-1 (35). It is clear that P-selectin and monocyte–platelet aggregates play a crucial role in the development of atherosclerosis, and blockade of this interaction may result in impairment of atherogenesis (4), improve coronary flow, and accelerate thrombolysis (36).

The density of P-selectin expression is much higher on activated platelets (about 350/ $\mu\text{m}^2$ ) than on endothelial cells (13,37–39). Therefore, tethering of circulating monocytes to activated platelets that are aggregated at a site of vascular injury probably plays a significant role in monocyte localization to the region of vascular injury. This process of monocytes tethering to platelets overlaying a plaque may contribute to the process of atherogenesis.

Treatment with GPIIb-IIIa antagonists for PCI reduces the formation of monocyte–platelet aggregates (9) as well as the release of soluble CD40L (40,41) and inhibits platelet activation, resulting in decreased monocyte–platelet aggregation and subsequent monocyte activation (41).



**Fig. 3.** Identification and quantification of monocyte–platelet aggregates using whole-blood flow cytometry. **(A)** Monocytes are identified based on light-scatter properties and differential cell-surface expression of the lipopolysaccharide receptor (CD14). **(B)** The monocytes are then analyzed for expression of platelet-specific antigens, in this case GPIIb (CD41). Expression of platelet-specific antigens on monocytes above isotype control represents monocyte–platelet aggregation. Monocyte–platelet aggregation is greater in patients with ischemic heart disease (magenta), than in healthy control subjects (yellow). FITC, fluorescein isothiocyanate; PE, phycoerythrin; SSC-H, side scatter.

## CONCLUSION

The interaction of monocytes and platelets is an important mediator of the interface between thrombosis and inflammation in the setting of ischemic heart disease. Monocyte–platelet aggregates are elevated in stable CAD and further elevate with plaque rupture, characteristic of PCI, acute coronary syndromes, and MI. Through this interaction, activated platelets may contribute to the pathogenesis of ischemic heart disease by localizing and activating monocytes to the site of the atherosclerotic lesion. These heterotypic aggregates have potential for a number of clinical applications, including measurement as an early marker for plaque rupture, evaluation of the efficacy of antiplatelet therapy, and as a potential target for therapeutic intervention. Additional studies to evaluate these applications as well as the relationship between monocyte–platelet aggregates and outcome are needed.

## REFERENCES

1. Libby P, Simon DI. Inflammation and thrombosis: the clot thickens. *Circulation* 2001;103:1718–1720.
2. McEver RP. P-Selectin/PSGL-1 and other interactions between platelets, leukocytes, and endothelium. In: Michelson AD, ed. *Platelets*. Academic, San Diego, 2002, pp. 139–155.
3. Palabrica T, Lobb R, Furie BC, et al. Leukocyte accumulation promoting fibrin deposition is mediated in vivo by P-selectin on adherent platelets. *Nature* 1992;359:848–851.
4. Huo Y, Schober A, Forlow SB, et al. Circulating activated platelets exacerbate atherosclerosis in mice deficient in apolipoprotein E. *Nat Med* 2003;9:61–67.
5. Schonbeck U, Libby P. CD40 signaling and plaque instability. *Circ Res* 2001;89:1092–1103.
6. Schonbeck U, Libby P. The CD40/CD154 receptor/ligand dyad. *Cell Mol Life Sci* 2001;58:4–43.
7. Furman MI, Benoit SE, Barnard MR, et al. Increased platelet reactivity and circulating monocyte–platelet aggregates in patients with stable coronary artery disease. *J Am Coll Cardiol* 1998;31:352–358.
8. Ott I, Neumann FJ, Gawaz M, Scmitt M, Schomig A. Increased neutrophil–platelet adhesion in patients with unstable angina. *Circulation* 1996;94:1239–1246.
9. Furman MI, Barnard MR, Krueger LA, et al. Circulating monocyte–platelet aggregates are an early marker of acute myocardial infarction. *J Am Coll Cardiol* 2001;38:1002–1006.

10. Michelson AD, Barnard MR, Krueger LA, Valeri CR, Furman MI. Circulating monocyte-platelet aggregates are a more sensitive marker of *in vivo* platelet activation than platelet surface P-selectin: studies in baboons, human coronary intervention, and human acute myocardial infarction. *Circulation* 2001;104:1533–1537.
11. Mickelson JK, Lakkis NM, Villarreal-Levy G, Hughes BJ, Smith CW. Leukocyte activation with platelet adhesion after coronary angioplasty: a mechanism for recurrent disease? *J Am Coll Cardiol* 1996;28:345–353.
12. Michelson AD, Barnard MR, Krueger LA, Frelinger AL, Furman MI. Flow cytometry. In: Michelson AD, ed. *Platelets*. Academic, San Diego, 2002, pp. 297–315.
13. Hsu-Lin SC, Berman CL, Furie BC, August D, Furie B. A platelet membrane protein expressed during platelet activation and secretion: studies using a monoclonal antibody specific for thrombin-activated platelets. *J Biol Chem* 1984;259:9121–9126.
14. Stenberg PE, McEver RP, Shuman MA, Jacques YV, Bainton DF. A platelet alpha-granule membrane protein (GMP-140) is expressed on the platelet membrane after activation. *J Cell Biol* 1985;101:880–886.
15. Michelson AD, Benoit SE, Kroll MH, et al. The activation-induced decrease in the platelet surface expression of the glycoprotein Ib-IX complex is reversible. *Blood* 1994;83:3562–3573.
16. Ruf A, Patscheke H. Flow cytometric detection of activated platelets: comparison of determining shape change, fibrinogen binding, and P-selectin expression. *Semin Thromb Hemost* 1995;21:146–151.
17. Michelson AD, Barnard MR, Hechtman HB, et al. *In vivo* tracking of platelets: circulating degranulated platelets rapidly lose surface P-selectin but continue to circulate and function. *Proc Natl Acad Sci USA* 1996;93:11,877–11,882.
18. Larsen E, Celi A, Gilbert GE, et al. PADGEM protein: a receptor that mediates the interaction of activated platelets with neutrophils and monocytes. *Cell* 1989;59:305–312.
19. Hamburger SA, McEver RP. GMP-140 mediates adhesion of stimulated platelets to neutrophils. *Blood* 1990;75:550–554.
20. Hidari KI, Weyrich AS, Zimmerman GA, McEver RP. Engagement of P-selectin glycoprotein ligand-1 enhances tyrosine phosphorylation and activates mitogen-activated protein kinases in human neutrophils. *J Biol Chem* 1997;272:28,750–28,756.
21. Blanks JE, Moll T, Eytner R, Vestweber D. Stimulation of P-selectin glycoprotein ligand-1 on mouse neutrophils activates beta 2-integrin mediated cell attachment to ICAM-1. *Eur J Immunol* 1998;28:433–443.
22. Evangelista V, Manarini S, Sideri R, et al. Platelet/polymorphonuclear leukocyte interaction: P-selectin triggers protein-tyrosine phosphorylation-dependent CD11b/CD18 adhesion: role of PSGL-1 as a signaling molecule. *Blood* 1999;93:876–885.
23. Weber C, Springer TA. Neutrophil accumulation on activated, surface-adherent platelets in flow is mediated by interaction of Mac-1 with fibrinogen bound to alphaIIb beta3 and stimulated by platelet-activating factor. *J Clin Invest* 1997;100:2085–2093.
24. Weyrich AS, Elstad MR, McEver RP, et al. Activated platelets signal chemokine synthesis by human monocytes. *J Clin Invest* 1996;97:1525–1534.
25. Ostrovsky L, King AJ, Bond S, et al. A juxtacrine mechanism for neutrophil adhesion on platelets involves platelet-activating factor and a selectin-dependent activation process. *Blood* 1998;91:3028–3036.
26. Simon DI, Chen Z, Xu H, et al. Platelet glycoprotein Iba1 is a counterreceptor for the leukocyte integrin Mac-1 (CD11b/CD18). *J Exp Med* 2000;192:193–204.
27. Diacovo TG, deFougerolles AR, Bainton DF, Springer TA. A functional integrin ligand on the surface of platelets: intercellular adhesion molecule-2. *J Clin Invest* 1994;94:1243–1251.
28. Sarma J, Laan CA, Alam S, Jha A, Fox KA, Dransfield I. Increased platelet binding to circulating monocytes in acute coronary syndromes. *Circulation* 2002;105:2166–2171.
29. Barnard MR, Krueger LA, Frelinger AL, Furman MI, Michelson AD. Whole blood analysis of leukocyte-platelet aggregates. In: Robinson JP, Darzynkiewicz Z, Dean PN, et al., eds. *Current Protocols in Cytometry*, vol. 1. John Wiley & Sons, New York, 2003, pp. 06.15.01–06.15.08.
30. Furman MI, Kereiakes DJ, Krueger LA, et al. Leukocyte-platelet aggregation, platelet surface P-selectin, and platelet surface glycoprotein IIIa after percutaneous coronary intervention: effects of dalteparin or unfractionated heparin in combination with abciximab. *Am Heart J* 2001;142:790–798.
31. Linden MD, Frelinger AL 3rd, Barnard MR, Przyklenk K, Furman MI, Michelson AD. Application of flow cytometry to platelet disorders. *Semin Thromb Hemost* 2004;30:501–511.
32. Rinder HM, Bonan JL, Rinder CS, Ault KA, Smith BR. Dynamics of leukocyte-platelet adhesion in whole blood. *Blood* 1991;78:1730–1737.
33. Mendelsohn ME, Loscalzo J. Role of platelets in cholesteryl ester formation by U-937 cells. *J Clin Invest* 1988;81:62–68.

34. Celi A, Pellegrini G, Lorenzet R, et al. P-selectin induces the expression of tissue factor on monocytes. *Proc Natl Acad Sci USA* 1994;91:8767–8771.
35. Neumann FJ, Zohlnhofer D, Fakhoury L, Ott I, Gawaz M, Schomig A. Effect of glycoprotein IIb/IIIa receptor blockade on platelet-leukocyte interaction and surface expression of the leukocyte integrin Mac-1 in acute myocardial infarction. *J Am Coll Cardiol* 1999;34:1420–1426.
36. Kumar A, Villani MP, Patel UK, Keith JC Jr, Schaub RG. Recombinant soluble form of PSGL-1 accelerates thrombolysis and prevents reocclusion in a porcine model. *Circulation* 1999;99:1363–1369.
37. Yuan Y, Kulkarni S, Ulsemer P, et al. The von Willebrand factor-glycoprotein Ib/V/IX interaction induces actin polymerization and cytoskeletal reorganization in rolling platelets and glycoprotein Ib/V/IX-transfected cells. *J Biol Chem* 1999;274:36,241–36,251.
38. Yeo EL, Sheppard JA, Feuerstein IA. Role of P-selectin and leukocyte activation in polymorphonuclear cell adhesion to surface adherent activated platelets under physiologic shear conditions (an injury vessel wall model). *Blood* 1994;83:2498–2507.
39. McEver RP, Martin MN. A monoclonal antibody to a membrane glycoprotein binds only to activated platelets. *J Biol Chem* 1984;259:9799–9804.
40. Furman MI, Krueger LA, Linden MD, Barnard MR, Frelinger AL 3rd, Michelson AD. Release of soluble CD40L from platelets is regulated by glycoprotein IIb/IIIa and actin polymerization. *J Am Coll Cardiol* 2004;43:2319–2325.
41. Furman MI, Krueger LA, Linden MD, et al. GPIIb-IIIa antagonists reduce thromboinflammatory processes in patients with acute coronary syndromes undergoing percutaneous coronary intervention. *J Thromb Haemost* 2005;3:312–320.





# VI

---

## BIOMARKERS OF DYSLIPIDEMIA AND LIPID MODIFICATION

---



# 29

---

## Measurement of Atherogenic Lipoproteins in Cardiovascular Risk Assessment

---

*Richard L. Dunbar, MD and Daniel J. Rader, MD*

### CONTENTS

HETEROGENEITY OF ATHEROGENIC LIPOPROTEINS
LDL CHOLESTEROL
NON-HDL-CHOLESTEROL
APOLIPOPROTEIN B
LDL PARTICLE NUMBER
LIPOPROTEIN(A)
WHAT MARKER OF ATHEROGENIC LIPOPROTEINS IS OPTIMAL FOR CLINICAL PRACTICE?
INCORPORATING LIPOPROTEIN NUMBER INTO TREATMENT OF LIPOPROTEIN DISORDERS
CONCLUSION
APPENDIX: CASE STUDY
REFERENCES

---

### SUMMARY

In the past several decades, multiple landmark clinical trials have proven that certain lipoprotein abnormalities not only predict but also provoke atherosclerotic cardiovascular disease. Yet, there is a growing concern that traditional measures of atherogenic lipoproteins do not faithfully forecast risk in some populations. For instance, while the singular importance of low-density lipoprotein (LDL) is unchallenged, novel laboratory techniques have emerged to characterize it. This has led to reassessment of which measures of LDL best correlate with outcomes. In this chapter, we will discuss important markers of LDL and selected atherogenic lipoproteins. Several emerging lipoprotein-related tests are now widely available, and it is not always easy to discern which ones best complement the traditional markers, or when to use them. We also discuss how Adult Treatment Panel III and other major consensus guidelines approach some of the lipoprotein-related markers. Finally, we move a step beyond current guidelines and propose a clinical strategy that leverages emerging lipoprotein markers to better identify at-risk patients.

**Key Words:** Apolipoprotein B; atherogenic dyslipidemia; cardiovascular risk; lipoprotein a; low-density lipoprotein; hypercholesterolemia; non-high-density lipoprotein.

From: *Contemporary Cardiology:  
Cardiovascular Biomarkers: Pathophysiology and Disease Management*  
Edited by: David A. Morrow © Humana Press Inc., Totowa, NJ

## HETEROGENEITY OF ATHEROGENIC LIPOPROTEINS

The pathogenesis of dyslipidemia revolves around the metabolism of lipoproteins. Comprising proteins and lipids (cholesterol, triglycerides [TGs], and phospholipids), lipoproteins are the vehicles for lipid transport. The proteins associated with a lipoprotein are known as apolipoproteins, and each atherogenic lipoprotein contains a single protein designated apolipoprotein B (apoB). Lipoprotein metabolism is largely governed by apolipoproteins, which operate as cofactors for enzymes, interact with cell-membrane receptors, and provide a structural framework for lipoproteins. Several lipoproteins are associated with atherosclerosis to varying degrees. The best established is low-density lipoprotein (LDL), which is also typically the most abundant atherogenic lipoprotein. Several other lipoproteins promote atherosclerosis, including very low-density lipoprotein (VLDL), intermediate-density lipoprotein (IDL), and lipoprotein(a) (Lp[a]). By contrast, high-density lipoprotein (HDL) appears to protect against atherosclerosis.

It is well established that the cholesterol content of LDL (LDL-cholesterol [LDL-C]) is a risk factor for atherosclerotic cardiovascular disease (ASCVD), and therapy that lowers LDL-C limits ASCVD events. This paradigm has spawned clinical guidelines that set convenient targets for LDL lowering (1–8). Yet many patients continue to have events despite reaching LDL-C targets, and many who have low LDL-C at baseline present with ASCVD events. Several studies suggest that even patients with “optimal” LDL-C levels benefit from lipid-lowering therapy. These observations have led to a search for other biomarkers that might predict risk of ASCVD events and, in particular, markers that refine the ability to forecast risk from atherogenic lipoproteins. Responding to these concerns, the Adult Treatment Panel III (ATP-III) proposed two important clinical tools to identify patients whose risk may be underestimated by traditional markers (1). First, it adopted a treatment goal based on non-HDL-C in patients with hypertriglyceridemia. Second, it emphasized the diagnosis of metabolic syndrome (1). Both conditions are associated with deleterious LDL abnormalities that are not detectable by estimating LDL-C content. This situation highlights an important limitation to using LDL *cholesterol* as a risk marker: this presumes that all LDL particles are uniformly atherogenic.

In fact, LDL is heterogeneous regarding size and density, which leads to important variability in the atherogenicity of these lipoproteins. The small, dense variety of LDL is thought to be especially atherogenic (9), owing to increased residence time in the circulation, reduced LDL receptor binding, heightened potential for oxidation, enhanced penetration of the artery intima, and increased retention therein (9). Elevated levels of TGs promote a shift to the small, dense form of LDL. The common association of high TGs, low HDL-C, and small, dense LDL is variably known as atherogenic dyslipidemia, the atherogenic lipoprotein phenotype, or simply the lipid triad, and itself may be considered an associated risk factor for ASCVD (1). This triad correlates with several metabolic abnormalities, including renal disease, metabolic syndrome, insulin resistance, and type 2 diabetes (1). Because there is no intervention that selectively improves small, dense LDL without affecting other lipoprotein fractions, it will be very difficult to prove that therapeutic intervention that targets small, dense LDL specifically reduces risk.

In some circumstances, it may be helpful to know whether a patient has increased levels of small, dense LDL because the finding is an important clue that the usual marker of LDL atherogenicity, LDL-C, may be leading to an underestimation of risk (10). There are several commercially available techniques that measure the size of LDL. These include analytic

Table 1  
Common Pitfalls Associated With LDL Cholesterol

---

*Circumstances in which lipoproteins in general may not reflect a patient's usual level (1)*

---

Acute illness  
 Acute coronary syndrome  
 Cerebrovascular accident  
 Surgery  
 Infection  
 Recent weight loss  
 Change in usual diet  
 Pregnancy

---

*Circumstances in which LDL-C approximation may not reflect a patient's LDL-C*

---

Frederickson class I, III, or V hyperlipoproteinemia (11)  
 Presence of chylomicrons (11)  
 Fasting <12 h (11,12)  
 TGs >200 (18,19) to 400 (11) mg/dL  
 Approximated LDL-C < 120 mg/dL (comparable with measured LDL-C < 130 mg/dL) (26)  
 Approximated LDL-C within 11 mg/dL of 100 mg/dL goal, within 15 mg/dL of 130 mg/dL goal, or within 18 mg/dL of 160 mg/dL goal (assuming two samples) (12)  
 Fewer than two samples available for interpretation (12)  
 Diabetes (17)  
 Liver disease (20)  
 Nephrotic syndrome (21) or chronic renal insufficiency (22,23)  
 Hormone replacement therapy (24,25)

---

ultracentrifugation, gradient gel electrophoresis, nuclear magnetic resonance (NMR) spectroscopy, and equilibrium density gradient ultracentrifugation (9). (See part I of the appendix.)

## LDL CHOLESTEROL

Lowering LDL has become the cornerstone of preventive care for at-risk patients with hyperlipidemia (1–8), and the evidence base from clinical trials is almost exclusively based on LDL-C. In the effort to alter LDL levels, clinicians must not forget that important changes in a patient's health can result in spurious lipoprotein levels (Table 1). Despite its well-deserved prominence, LDL-C is almost never directly *measured*, either in clinical trials or in practice. Ironically, the single most important lipoprotein is routinely *approximated*, using a method proposed by Friedewald et al. (11) in the early 1970s:

$$\text{LDL}_C \approx \text{Total Cholesterol} - \text{HDL-C} - \frac{\text{TGs}}{5}$$

This approximation is currently used not only to diagnose a variety of lipoprotein disorders but also to track therapy. Clinical guidelines tie efficacy to the attainment of various cutoffs based on the LDL-C approximation. Because herein we frequently distinguish between directly measured LDL-C and its approximation, we reserve the term *LDL-C* for *measured* LDL-C and refer to the *approximated* variable as *~LDL-C*.

### ***Origin of LDL-C Approximation***

The “gold standard” for measuring LDL-C content involves ultracentrifugation and precipitation, also known as  $\beta$ -quantification. Because  $\beta$ -quantification is laborious, the Friedewald approximation has been used for more than 30 yr to estimate LDL-C without using an ultracentrifuge (11). The approximation was proposed for the express purpose of estimating the cholesterol content of LDL to classify subjects into the Frederickson classifications of hyperlipoproteinemia, especially type II (11). The 448 serum samples used did not come from a population sample but, instead, reflected the research interests of the National Institutes of Health during the late 1960s and early 1970s. Samples were obtained from other studies that examined familial hyperlipoproteinemia and included probands and family members. No other demographic data on the population were given. Of the 448 samples, 96 had normal cholesterol according to practice standards in the early 1970s, 204 had type II hyperlipoproteinemia, and 148 had type IV. The investigators noted that their method made several critical assumptions:

1. The ratio of TGs/VLDL-C is constant within and between individuals.
2. The ratio of TGs/VLDL = 5.
3. The approximation is invalid in the presence of chylomicrons (thus, invalid in type I and V hyperlipoproteinemia, and inadequate fasting).
4. The approximation is invalid in type III hyperlipoproteinemia.

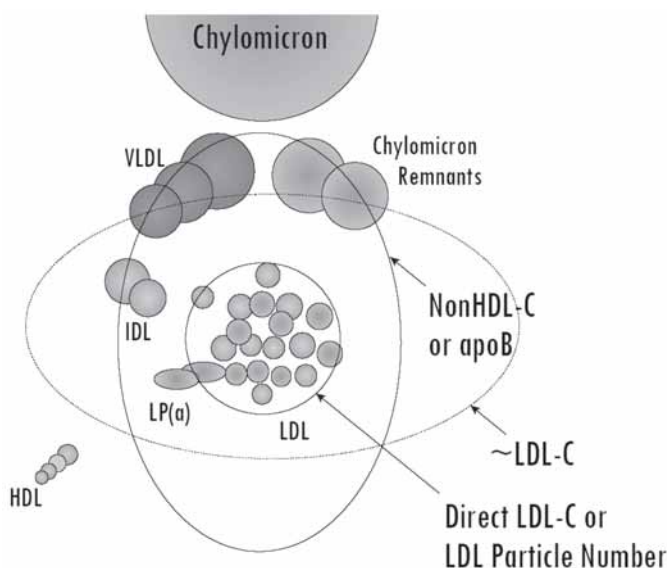
They reported correlation coefficients among normal samples and type II samples that approached 1.0, but weaker correlation (0.85) and many outliers in the type IV samples, with considerable spread from the line. Because the analysis of the type IV samples yielded an unacceptable result, they selectively excluded about 25% of the samples (those with TGs > 400 mg/dL) and repeated the analysis *post hoc*. The revised selection then yielded an improved correlation coefficient of 0.94, although subjects were still widely distributed about the line. The average absolute error was 4% for normal subjects, 3% for type II, and 7% for the *post hoc* sample of type IV samples. Interestingly, the data showed that TG/5 failed to estimate VLDL-C in any of the three groups.

### ***What Does the LDL-C Approximation Estimate?***

The Friedewald approximation attempts to estimate the cholesterol content contained in lipoproteins other than HDL with a correction term, TG/5, to reduce the influence of VLDL-C. Even when the approximation was proposed, the correction term was shown not to reflect VLDL-C accurately (11). The term TG/5 probably accounts for TGs in a variety of different lipoproteins. The  $\sim$ LDL-C approximates the cholesterol content of LDL, IDL, VLDL/VLDL-remnants, and Lp(a) (12). Thus, the term *LDL-C* is somewhat a misnomer, and the approximation might be thought of as a gage of the cholesterol content of “mixed-density lipoproteins,” as shown in Fig. 1. The major source of error in  $\sim$ LDL-C stems from the enigmatic correction term (13).

### ***Imprecision of LDL-C Approximation***

The National Cholesterol Education Program (NCEP) emphasizes that clinicians should be aware of the limitations of the Friedewald equation that we have noted (12). The ideal use of the approximation involves a 12-h fast; clinicians should be aware that even a 9-h fast will underestimate LDL-C by at least 2–4% (e.g., 3–6 mg/dL less in a patient with a measured LDL-C of 150 mg/dL). To establish an  $\sim$ LDL-C within a 10% error limit, the



**Fig.1.** Lipoproteins reflected by selected markers. Note that LDL-C and non-HDL-C measure the *cholesterol content* of the lipoproteins shown, whereas apoB and LDL particle number assess the *number of particles*.

NCEP estimated that it would be necessary to collect four samples on different days. It also estimated that by averaging two ~LDL-C readings and using a cut point of 130 mg/dL, a result of >145 mg/dL is reliably above the cutoff, and a result of <115 mg/dL is reliably below the cutoff (12). Thus, if a patient's goal is an LDL-C of <130 mg/dL, and the average of two samples on different days shows that medication lowered the ~LDL-C to 115 mg/dL or less, by the NCEP analysis the clinician can be reasonably confident that the patient has reached the goal. If only one reading is available, it is not certain whether the patient has reached the goal, because the error interval is larger. This wide range of error betrays a conceptual problem with using ~LDL-C in practice: because the cutoffs in the ATP-III guidelines are spaced in 30-mg/dL intervals (i.e., 70, 100, 130, and 160 mg/dL) (2), and the margin of error is at least 15 mg/dL with repeated sampling, the approximation may be poorly suited to pursue such fine distinctions in the clinical setting. The problem is further compounded by the reliance on solitary samples to assess efficacy.

The multitude of errors related to the approximation led the NCEP to recommend the development of direct measures of LDL-C, with the ultimate goal of phasing out the approximation (12). Several assays directly measure LDL-C without ultracentrifugation and are superior to the approximation when TGs exceed 400 mg/dL; unfortunately, below this level, these assays do not improve on the performance of the approximation (14).

### ***Problems With Clinical Application of LDL-C Approximation***

As the understanding of lipoprotein disorders has advanced, it has become more apparent that the LDL-C approximation has important clinical limitations (Table 1) (15).

#### **POTENTIAL FOR MISCLASSIFICATION**

The LDL-C approximation has been extended from a small study of a highly selected population to estimate risk and govern the therapy of millions of patients around the globe. The assumptions regarding TG/VLDL-C and its value have not held up to scrutiny (16–18).



Subsequent studies have shown that the  $\sim$ LDL-C does not compare well with  $\beta$ -quantification in some populations. For example, only 49 (16) to 68% (17) of patients with diabetes had an  $\sim$ LDL-C that was within 10% of measured LDL-C. The bias of  $\sim$ LDL-C exceeded 10% when TGs were between 200 and 249 mg/dL and worsened with each increment in TGs (17). A similar pattern was seen in patients without diabetes with TGs  $\geq$ 200 mg/dL (18). Another study found that the error associated with  $\sim$ LDL-C started to exceed 10% when TGs exceed 177 mg/dL (19). The ATP-III concluded that when triglycerides exceed 200 mg/dL, “LDL cholesterol alone inadequately defines the risk associated with atherogenic lipoproteins” (ref. 1, p. 370). The LDL-C approximation is also unreliable in patients with liver disease (20), nephrotic syndrome (21), or chronic renal insufficiency (22,23), and in women taking hormone replacement therapy (24). The approximation also suffers by the routine failure to exclude samples that contain chylomicrons, resulting from incomplete fasting or inherent chylomicronemia from type I and V hyperlipoproteinemia (11). Another set of problems arises because the approximation was intended to distinguish only two groups. By extending the approximation to delimit four (1) or five (2) groups with tight ranges, clinical guidelines compound the potential for misclassification (18).

#### IMPACT OF TREATMENT

The study by Friedewald et al. (11) did not include treated patients. Using the approximation to assess efficacy of therapy introduces an entire new suite of potential errors, because  $\sim$ LDL-C may lose its ability to predict risk in patients on lipid-lowering therapy (25). Of particular importance to clinical use,  $\sim$ LDL-C values that are low or low-normal values are especially prone to error (12,26,27). One study found that the approximation systematically underestimates LDL-C, and the degree of bias worsens with lower LDL-C levels (26). For patients with measured LDL-C < 100 mg/dL, the average  $\sim$ LDL-C was 18.3% lower, and about 40% of those with measured LDL-C between 100 and 130 mg/dL had an  $\sim$ LDL-C that was more than 10% lower. Most of the patients with measured LDL-C > 130 mg/dL had an  $\sim$ LDL-C that was within 10% of the actual value, although most of the bias tended toward underestimation (26). The tendency for  $\sim$ LDL-C to underestimate LDL-C was not related to TG levels (26). Because the patients at highest risk have the lowest LDL-C target (e.g., LDL-C of <100 or <70 mg/dL), underestimating LDL-C may have greater clinical repercussions in that population. This systematic error also makes it very difficult to interpret clinical trials that enrolled patients with  $\sim$ LDL-C in the low-normal range, because treatment effects cannot be reliably linked to baseline LDL-C.

#### NON-HDL-CHOLESTEROL

Responding to well-founded concerns over the use of  $\sim$ LDL-C, the ATP-III advised calculating the non-HDL-C as a secondary target of therapy in patients with TGs between 200 and 499 mg/dL (1). For comparison, we have shown both cholesterol markers in the following equations. The non-HDL-C marker refines the LDL-C approximation by dropping the term TG/5.

$$\text{non-HDL}_C = \text{Total}_C - \text{HDL}_C \quad \text{LDL}_C \cup \text{Total}_C - \text{HDL}_C - \frac{\text{TGs}}{5}$$

This simple change improves on several of the inherent problems of the approximation for LDL-C. The Friedewald equation relies on the questionable premise that TG/5 estimates VLDL-C. Because VLDL and its remnants are atherogenic, the ATP-III concluded

that reincorporating them enhances risk prediction. Non-HDL-C reflects the cholesterol content of all apoB-containing lipoproteins (Fig. 1). Furthermore, non-HDL-C requires neither fasting nor additional costs. ATP-III supported the use of non-HDL-C with several lines of evidence. A large study showed that non-HDL-C was a better correlate for coronary mortality than ~LDL-C (27). Moreover, at least a dozen studies showed that apoB is a strong predictor of coronary heart disease (CHD) and events. Finally, these studies emphasized that there is a strong correlation between non-HDL-C and apoB levels (1). Thus, much of the appeal of non-HDL-C is tied to its relationship to apoB.

An important difference between non-HDL-C and apoB is that apoB measures the number of atherogenic lipoprotein particles, whereas non-HDL-C measures the mass of cholesterol that these particles contain. Grundy observed that the correlation between non-HDL-C and apoB is especially reliable when TGs are normal but deteriorates with rising TGs (28). Although it adds complementary information to ~LDL-C, non-HDL-C also has limitations. A concordance/discordance analysis from the Quebec Cardiovascular Study revealed discordance between non-HDL-C and apoB in more than one-third of the subjects (29). This may be explained by the observation that variations in the ratio of cholesterol to TG composition or lipoprotein size alter the relationship between cholesterol mass and particle number. The discordance between non-HDL and apoB was studied in greater detail using data from the Insulin Resistance Atherosclerosis Study (IRAS) (30). apoB was significantly better correlated with ASCVD risk factors than non-HDL, including measures of obesity, blood pressure (BP), insulin resistance, and inflammation (e.g., high-sensitivity C-reactive protein [hsCRP]). Because apoB and non-HDL are correlated, the analysis was repeated, correcting each marker for the other. Correcting apoB for non-HDL strengthened apoB's correlation with risk factors. In stark contrast, correcting non-HDL for apoB negated non-HDL's correlation with risk factors. In fact, non-HDL became *inversely* correlated with several risk factors, and this striking finding was even more pronounced among patients with metabolic syndrome. Given its poor concordance with apoB from other trials, this study raises further questions about the validity and utility of non-HDL.

The recommended therapeutic targets for non-HDL-C depend on the risk assessment for a given patient, much like ~LDL-C targets (1). Ideally, VLDL-C should not exceed 30 mg/dL. Thus, the ATP-III advised that the non-HDL-C goal is simply defined as the ~LDL-C goal plus 30 (Table 2). The ATP-III preferred non-HDL-C over apoB for three reasons. First, at the time, the standardized assay for apoB was not as widely available to clinicians. Second, although there were prospective studies showing that apoB had superior predictive power to non-HDL-C, the collective evidence was not sufficient for this conclusion to be robust at that time. Third, measuring apoB would entail additional short-term cost. (See part II of the appendix.)

## APOLIPOPROTEIN B

apoB has emerged as an alternative to ~LDL-C and non-HDL-C. Because each atherogenic lipoprotein contains one apoB molecule (31), the level of apoB may effectively measure the number of atherogenic lipoproteins. Early attempts to test this use of apoB met with mixed success, because the few published studies were limited by unreliable assays, selective populations, and design problems, thus relegating the role of apoB to an additional risk marker in patients with personal or family history of premature CHD (32). However, subsequent stronger data support a wider use of apoB. The assay has been

Table 2  
Recommended Primary and Secondary Targets for Treatment of Dyslipidemia (in mg/dL)<sup>a</sup>

	2001: ATP-III guidelines (1)	2002: Grundy (10,28)	2003: Canadian guidelines (4)	2004: ATP-'04 update (2) optional goals
<i>High risk</i>				
CHD or CHD risk equivalent or FRS ⊕ 20%	1. LDL < 100 2. non-HDL < 130	1. LDL < 100 2. non-HDL < 130 or apoB < 90	1. LDL < 97 or apoB < 90 2. Total:HDL < 4	Optional goals for patients with very high risk <sup>b</sup> 1. LDL < 70 2. non-HDL < 100
<i>Moderate risk</i>				
⊕2 risk factors or FRS 10–20%	1. LDL < 130 2. non-HDL < 160	1. LDL < 130 2. non-HDL < 160 or apoB < 110	1. LDL < 135 or apoB < 105 2. Total:HDL < 5	Optional goals for patients with moderately high risk <sup>c</sup> 1. LDL < 100 2. non-HDL < 130
<i>Low risk</i>				
≤1 risk factor and FRS < 10%	1. LDL < 160 2. non-HDL < 190	1. LDL < 160 2. non-HDL < 190 or apoB < 130	1. LDL < 174 or apoB < 120 2. Total:HDL < 6	

<sup>a</sup>The LDL goals for the Canadian guidelines have been restated in milligrams per deciliter for consistency across the table. The source gives goals in millimoles per liter, and the corresponding goals are <2.5, <3.5, and <4.5 mmol/L, respectively. Likewise, apoB goals have been restated in units of milligrams per deciliter, rather than grams/liter.

<sup>b</sup>Very high risk motivating a goal of LDL < 70 mg/dL might consist of established vascular disease plus any of the following (2): ⊕2 major risk factors (especially diabetes), severe or poorly controlled risk factors (especially continued tobacco abuse), multiple risk factors of metabolic syndrome (especially dyslipidemia), acute coronary syndrome.

<sup>c</sup>Moderately high risk motivating a goal of LDL < 100 mg/dL might include advanced age, >2 major risk factors, severe risk factors (e.g., tobacco abuse, strong family history of premature CHD), TGs ⊕ 200 mg/dL and non-HDL ⊕ 160 mg/dL, HDL < 40 mg/dL, metabolic syndrome, hsCRP > 3 mg/L, or coronary calcium > 75th percentile (2).

FRS, Framingham Risk Score.

standardized (33), and several large prospective population-based studies have affirmed that apoB is both a marker of risk and a reasonable target of therapy (28,34,35).

### *Association With Clinical Events*

The Apolipoprotein-Related Mortality Risk study was designed to assess the ability of apolipoproteins, including apoB, to predict fatal myocardial infarction (MI) in a large unselected population (36). More than 175,000 men and women were followed for over 5 yr. The risk ratios associated with apoB were higher than those of ~LDL-C, and the receiver operator curves showed that apoB had higher sensitivity and specificity than ~LDL-C in predicting events. LDL-C was approximated by a previously validated alternative to the Friedewald equation. A test for interaction between apoB and ~LDL-C showed that both convey unique information about risk, and that apoB better predicts events than ~LDL-C at lower levels of either ~LDL-C or apoB (36). Extended follow-up of the population appeared to enhance the advantage of apoB over ~LDL-C as a risk indicator (35). A similar study evaluated approx 2500 men but extended the outcome to include incidence of fatal or nonfatal MI, coronary artery surgery, and silent MI (37). This study affirmed apoB as a strong predictor of events.

### *Association With Other Risk Indicators*

Another substudy from the IRAS study compared ~LDL-C with apoB as a correlate for a variety of ASCVD risk factors, including dyslipidemia, insulin resistance, hypertension, inflammation, thrombosis, and subclinical atherosclerosis (38). This interesting comparison examined differences between a group who had high ~LDL-C but normal apoB (i.e., high cholesterol mass distributed among a normal number of particles) and a group who had normal ~LDL-C but high apoB (i.e., normal cholesterol mass distributed among a larger number of particles). The latter hyper-apoB group had significantly higher TGs, fasting and 2-h insulin, and plasminogen activator inhibitor, and lower HDL-C, LDL particle size, and age than the group with isolated ~LDL-C elevation. This analysis raises the possibility that the normal ~LDL-C in the hyper-apoB group is not reassuring. Because apoB is a measure of particle number, this finding points to a discrepancy between the ~LDL-C and the number of atherogenic particles. Moreover, the magnitude of correlation with a variety of other risk markers was generally greater for apoB than ~LDL-C. Surprisingly, when ~LDL-C was adjusted for apoB, it switched from being a positive correlate with the other risk factors to a negative correlate. However, adjusting apoB for ~LDL-C magnified the strength of apoB as a positive correlate with the other risk factors. Similarly, when both apoB and ~LDL-C were adjusted by the Framingham Risk Score, apoB gained strength as a positive correlate, whereas ~LDL-C was weakened. Although this study was not based on outcomes, it lends credence to the idea that apoB can reveal residual risk associated with lipoproteins beyond ~LDL-C.

A substudy from the Quebec Cardiovascular Study evaluated the concordance and discordance between the different risk markers apoB, ~LDL-C, and non-HDL-C among men without CHD (27). Although apoB and ~LDL-C correlated with each other ( $\rho = 0.78$ ;  $p < 0.001$ ), only half of the subjects were in the same quintiles of each marker (i.e., 50% concordance between the markers). Concordance was below 40% for the middle three quintiles, corresponding with an ~LDL-C between 120 and 180 mg/dL. This reinforces the notion that ~LDL-C is not reliably related to the number of lipoproteins; thus, apoB may provide novel information beyond ~LDL-C.

### ***Impact of Therapy***

Some lipid trials have found that ~LDL-C loses predictive ability with treatment. The Air Force/Texas Coronary Atherosclerosis Prevention Study enrolled low- to moderate-risk subjects who had low HDL-C (mean: 37.5 mg/dL), but average ~LDL-C (mean: 154 mg/dL) and randomized to lovastatin or placebo (39). A substudy confirmed that baseline ~LDL-C, HDL-C, and apoB predicted events. While on-treatment levels of ~LDL-C and HDL-C lost this ability, apoB remained a strong predictor during treatment (25). Hence, the investigators suggested that apoB might be a more reliable variable to follow, especially in a population that does not have an especially high ~LDL-C. The Scandinavian Simvastatin Survival Study (4S) enrolled high-risk patients with higher ~LDL-C (mean: 188 mg/dL), finding that both ~LDL-C and apoB strongly predicted events in baseline and on-treatment samples (40). Together, these studies suggest that apoB may have an advantage at lower levels of ~LDL-C.

### ***Clinical Applications of apoB (see also Incorporating Lipoprotein Number Into Treatment of Lipoprotein Disorders)***

apoB has gained support as a risk marker from several recent analyses that have directly compared apoB to ~LDL-C (34,35). Grundy outlined the advantages and disadvantages of non-HDL-C and apoB and concluded that apoB is a reasonable alternative to non-HDL-C and proposed practical cutoffs (Table 2) (28). Updated prevention guidelines from the Canadian Cardiovascular Society (CCS) (4) and Canadian Diabetes Association (41) have also introduced apoB as an alternative to ~LDL-C. The CCS notes that apoB is especially useful for patients with metabolic syndrome and for following patients on lipid-lowering therapy (Table 2).

### **LDL PARTICLE NUMBER**

No doubt, the ATP-III strategy emphasizing metabolic syndrome and following non-HDL-C will detect many individuals who warrant aggressive preventive efforts. However, the objective to better identify at-risk patients has prompted new discussion on how to measure lipoproteins (28,34,42,43). The ideal measure of dyslipidemia might be to estimate the number of lipoprotein particles, because LDL-C does not distinguish small, dense LDL, and particle number may actually correlate more closely with outcomes than level of LDL-C does (10). Direct measurement of LDL particle number has been elusive because of technical limitations. However, a technique to measure LDL particle number is now clinically available. apoB levels also correspond to the number of atherogenic lipoprotein particles. Hence, the differences between particle number and cholesterol content apply to apoB as well.

### ***Particle Number vs Cholesterol Content of Atherogenic Lipoproteins***

Clinically, lipoproteins are characterized according to the mass of the cargo that they carry, i.e., the mass of cholesterol within them. This would be analogous to trying to approximate the number of cargo ships in a fleet by evaluating the collective mass of the containers on the decks of the ships at a point in time, which would be accurate only if the ships were all the same size and nearly always carried the same volume of goods of uniform mass. The relationship would be less reliable if different ships had different capacity, or if ships were

running under or over pattern, or even if the cargo itself were lighter or heavier than usual. In the same way, gauging the atherogenic potential of lipoproteins by estimating the collective mass of cholesterol is not always straightforward. The relationship between lipoprotein particle number and cholesterol content varies widely, because the carrying capacity varies with the size of the lipoprotein, and each lipoprotein's internal ratio of TGs to cholesterol is altered by many factors.

### ***Problems With Using LDL-C as a Marker of LDL Particle Number***

In addition to the difficulties with the LDL-C approximation, there are further problems with the use of LDL-C in general, even if it is directly measured. Since LDL-C is proportional to the number of LDL particles, one might expect the two to change in the same direction, even if the magnitude of change were to vary widely. Unfortunately, there are certain situations in which an increase in LDL-C may signal a decrease in LDL particle number.

#### **THEORETICAL PROBLEMS RELATING LDL-C TO PARTICLE NUMBER**

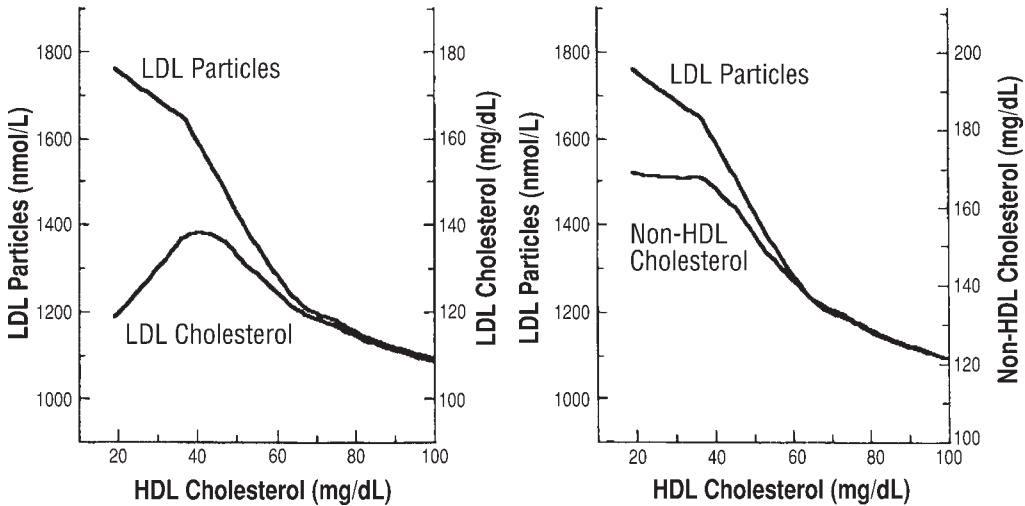
The cholesterol content of LDL depends on other variables, such as the volume of the LDL particles and the ratio of cholesterol to TGs within the particle. The following statement presents a simplified form of the relationship:

$$\sim\text{LDL}_C \propto \left[ \begin{array}{l} \text{LDL} \\ \text{IDL} \\ \text{LP(a)} \\ \text{VLDL} \\ \text{HDL} \end{array} \text{ Particle Number} \leftrightarrow \text{Particle Volume} \leftrightarrow \frac{\text{Cholesterol}}{\text{TG}} \right] - \text{HDL}_C - \frac{\text{TGs}}{5}$$

We have expressed the relationship mathematically not only to illustrate its complexity, but also to convey which variables are directly, as opposed to inversely, proportional to  $\sim\text{LDL-C}$ . It is natural to expect that increased  $\sim\text{LDL-C}$  represents an increased number of lipoprotein particles. However, the statement given reveals that the overall cholesterol mass would also increase if the particles were larger, or even if the ratio of cholesterol to TG increased. On the other hand, there are several conditions in which lipoproteins are enriched with TGs (e.g., metabolic syndrome or type 2 diabetes). Note that TGs appear in the statement twice, potentially magnifying their influence. Because TGs are inversely proportional to  $\sim\text{LDL-C}$ , hypertriglyceridemia may be associated with lower  $\sim\text{LDL-C}$  levels, thereby underestimating the LDL particle number. Likewise, if the LDL particles tend to be smaller than usual, the  $\sim\text{LDL-C}$  might underestimate the LDL number, even if the particles were more numerous than usual.

#### **CLINICAL RAMIFICATIONS**

Many clinicians assume that  $\sim\text{LDL-C}$  correlates with the number of LDL particles. The presumption of a stable relationship rests on the questionable assumption that all the other variables are constants or that their collective effects cancel each other out. In practice, the complex changes can actually result in retrograde changes in  $\sim\text{LDL-C}$  with respect to LDL particle number. When treatment favorably increases LDL particle size or increases the ratio of LDL cholesterol:TGs,  $\sim\text{LDL-C}$  may rise, despite a fall in the number of LDL particles (44). This may lead the clinician to assume that treatment was deleterious, when in all likelihood, it was beneficial. This renders the relationship between  $\sim\text{LDL-C}$  and LDL number unpredictable, because we cannot assume that these variables will change in the same direction.



**Fig. 2.** These graphs from the Framingham Offspring Study show that the relationship between LDL-C content and LDL particle number is complex and not always predictable(43). Although the degree and direction of variance is smaller with non-HDL-C content, it too has a complex relationship to LDL particle number. (Reprinted from ref. 43 with permission from Excerpta Medica, Inc., Copyright 2002.)

### *Measuring LDL Particle Number*

The number of LDL particles can be directly measured by NMR spectroscopy, as can the number of the other atherogenic lipoproteins (43). Emerging data suggest that the LDL particle number may also be a better predictor of ASCVD events than ~LDL-C. A substudy from the Framingham Offspring Study analyzed more than 3400 samples by NMR and compared ~LDL-C to LDL particle number (43). This analysis demonstrated a striking degree of variance in the relationship between ~LDL-C and LDL particle number (Fig. 2), especially when HDL-C was <40 mg/dL. This observation suggests that low HDL-C may serve as a marker for an LDL problem that escaped detection using LDL-C content and raises the possibility that some of the apparent risk associated with low HDL-C may be related to increased LDL particle number. The graphs in Fig. 2 illustrate a complex relationship between lipoprotein number and cholesterol content. Note that subjects with an HDL-C of 20 mg/dL had the highest number of LDLs but had “normal” approximated LDL-C (about 120 mg/dL). Presumably, these subjects had smaller LDL particles, decreased cholesterol:TG composition of their LDL, or both. Because the smaller LDL particles may be more atherogenic (9), these subjects may have substantial unappreciated risk. The ATP-III proposed that measuring the cholesterol content of non-HDLs should reduce some of the uncertainty surrounding ~LDL-C (1). However, an analysis from the Framingham study revealed that the relationship between non-HDL-C and LDL particle number also deteriorates when HDL-C is <40 mg/dL (Fig. 2). non-HDL-C is relatively flat in this range, so it can no longer predict the number of LDL particles.

A concordance/discordance analysis from the Framingham study evaluated the ability of ~LDL-C to correctly identify subjects with LDL particles over the 80th percentile (43). Only 62% of the population had concordant results (i.e., both ~LDL-C and LDL particles above the cutoff); the remaining 38% had the discordant finding of LDL particles above the 80th percentile, but ~LDL-C below this cutoff. At the other extreme, 34% of the

patients with “optimal” ~LDL-C, i.e., below the 20th percentile, had an LDL particle number above this cutoff. Because the pathogenesis of atherosclerosis centers on atherogenic lipoproteins, withholding therapy from patients with numerous LDL particles because they have an acceptable ~LDL-C may result in undertreatment of a high-risk group. Conversely, a screening approach that overcomes the unpredictable relationship between ~LDL-C and LDL particle number may result in more effective prevention, simply by reducing misclassification errors.

Retrograde ~LDL-C changes were seen in the Veterans Affairs HDL Intervention Trial (VA-HIT), which randomized patients with coronary disease and low HDL-C to placebo or gemfibrozil (45). Gemfibrozil improved the cholesterol profile by raising HDL-C by 6% and decreasing TGs 29%, and the HDL-C changes helped to explain a significant reduction in ASCVD events (46). ~LDL-C increased 2% from baseline and did not predict events. By contrast, an unpublished subgroup analysis revealed that LDL particle number declined by 3%; small, dense LDL particles decreased 29%; and large LDL particles increased 31% (47). Even after adjustment for cholesterol values, baseline and on-treatment LDL particle number predicted ASCVD events (48), although treatment apoB levels did not (46). In summary, ~LDL-C represented a retrograde change, masking an important improvement in LDL. The results of VA-HIT are a reminder that changes in ~LDL-C may not always be a reliable marker of lipoprotein changes.

### LIPOPROTEIN(A)

Lp(a) is an LDL whose apoB molecule forms a disulfide bridge to a hydrophilic, glycosylated protein called apo(a). Although the length of the apo(a) varies considerably, the molecule maintains a resemblance to plasminogen. This homology has been proposed as a reason that Lp(a) is deleterious, presumably by competing with plasminogen, and interfering with fibrinolysis. However, other deleterious effects are likely, such as the particles' large cholesterol pool and predilection for infiltrating atherosclerotic plaques (49).

#### *Association With Outcomes*

A meta-analysis of 18 prospective studies included more than 4000 subjects free of ASCVD at baseline; comparing those in the highest tertile of Lp(a) to the lowest tertile, the risk ratio for incident events was 1.7 (95% confidence interval [CI]: 1.4–1.9) (50). This result was confirmed in a large prospective analysis that followed more than 9000 subjects for 5 yr and found a risk ratio of 1.56 for fatal and nonfatal MI and angina (95% CI: 1.10–2.21) when comparing the highest quartile of Lp(a) to the lowest (51). A substudy suggested that concomitant elevation of LDL-C magnified the risk of Lp(a). A study of 5800 subjects older than 65 yr found that Lp(a) predicted ASCVD events only in men (52). These studies support Lp(a) as an associated risk factor for ASCVD. Without an intervention that selectively lowers Lp(a), it would be very difficult to determine whether Lp(a) is a true risk factor, as opposed to merely a marker for risk. The ATP-III does not advocate routinely measuring Lp(a), citing uncertainty of its being an independent risk factor, variation in measurement methods, and expense (1). Although niacin and estrogen may lower Lp(a), there is no evidence that either treatment improves outcomes on that basis. Nonetheless, the guidelines suggest that it may be reasonable to count Lp(a) as an additional risk factor in selected patients, such as those with a family history of premature ASCVD or with familial hypercholesterolemia (1).



### ***Clinical Application of Lp(a) (see also Incorporating Lipoprotein Number Into Treatment of Lipoprotein Disorders)***

On occasion, measuring Lp(a) may be clinically useful in minimizing a possible confounding effect on the interpretation of LDL-C. This may be particularly important for African Americans, whose levels of Lp(a) are two to three times that of Caucasians (53, 54). Despite higher levels, fewer African Americans have a form of Lp(a) that correlates with ASCVD events (1,55,56). This may lead to two important clinical difficulties in interpreting LDL-C in African Americans. First, a high Lp(a) may inflate the LDL-C level, potentially leading to unnecessary treatment. Second, following LDL-C for efficacy is problematic, because Lp(a) largely resists changes with statins and fibrates, rendering a portion of a patient's "LDL-C" unresponsive to therapy (53). This phenomenon may create the illusion that LDL-C is refractory to treatment. In the right setting, Lp(a) can be measured and LDL-C corrected according to the following formula (12) (see part III of the appendix):

$$\text{LDL}_C \cup \text{LDL}_C \text{ (direct or approximated)} - 0.3 \text{ Lp(a) (in mg/dL)}$$

### **WHAT MARKER OF ATHEROGENIC LIPOPROTEINS IS OPTIMAL FOR CLINICAL PRACTICE?**

The proliferation of lipid measures has led to an often confusing array of biochemical parameters, including actual measures of lipoproteins, surrogate measures, and even approximations of surrogate measures. The list has expanded to accommodate apolipoproteins; variant lipoproteins (e.g., Lp[a]); and even lipoprotein density, size, and number. Despite such refinements, there is a growing sense that the totality of lipid analysis still fails to detect many patients who have substantial residual risk of ASCVD. In turn, this disappointing outcome has fueled intense interest in emerging risk factors. We wonder how much of this effort is simply an unwitting attempt to compensate for a marker that often masks risk.

We are reminded of the increasingly complex machinations used to refine Ptolemy's geocentric model of the universe. Despite the enthusiastic addition of epicycles and equants, no amount of tinkering with the geocentric model could explain the movements of the planets better than Copernicus's elegant (if flawed) heliocentric model of the universe. In the same vein, we propose that the treatment of hyperlipoproteinemia is made more difficult than it needs to be because it is based on a series of outmoded suppositions. First, the current model places cholesterol mass in the center of the lipid universe, both for forecasting risk and for assessing benefit. Second, it generalizes the Friedewald approximation far beyond the narrow intended purpose, without due consideration of discordant data from larger, population-based studies. Third, clinicians are expected to keep track of a long list of exceptions to the approximation, including retrograde motion of ~LDL-C, in which ~LDL-C moves in the opposite direction of LDL particle number. We submit that a model based on atherogenic lipoprotein number could provide a more satisfying approach to prevention, because it better fits the understanding of atherosclerosis and advances in the understanding of the biology and interrelationships of lipoproteins.

### **INCORPORATING LIPOPROTEIN NUMBER INTO TREATMENT OF LIPOPROTEIN DISORDERS**

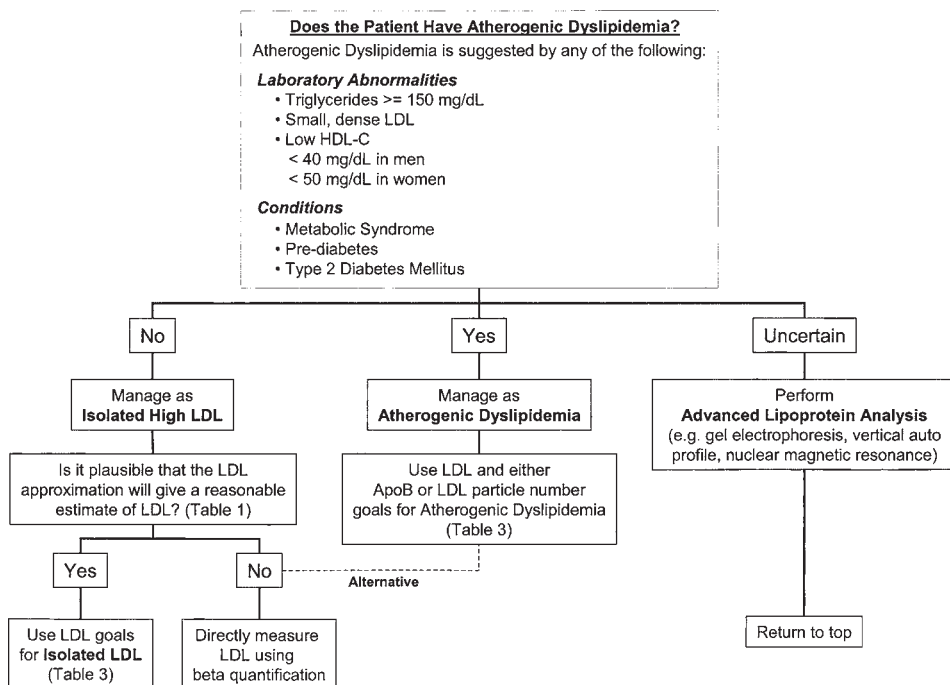
Because public health efforts and the direction of clinical research have been based around the cholesterol model for so long, a fundamental change to a measure of atherogenic lipoprotein number could have important drawbacks. First, most of the evidence

base is reported in terms of ~LDL-C. Indeed, the reliance on ~LDL-C is so ingrained that it almost requires researchers to reinterpret studies that actually measured LDL-C, just to make the results align with studies that used the weaker surrogate, ~LDL-C (2). Switching entirely to lipoprotein number would steer researchers into uncharted waters, with comparatively little evidence to guide them. Second, as Grundy (28) points out, the hugely successful efforts to educate physicians and patients about the evidence-based supremacy of LDL-C might make it hard to reorient prevention efforts along the lines of lipoproteins. Third, the additional cost of measuring lipoprotein number is not trivial. Although all are valid concerns, we doubt they will prove insurmountable.

Grundy (10,28) has proposed incremental strategies, later adopted by the CCS (4) and the Canadian Diabetes Association (41), that have potential value. These clinical guidelines introduce measures of particle number alongside the traditional cholesterol surrogates (Table 2). Such strategies maintain the use of ~LDL-C but add apoB as an alternate target of therapy. Thus, a patient who has reached the ~LDL-C goal but still has an elevated apoB likely has small, dense LDL that represents further risk that is undetectable by the ~LDL-C alone.

The ATP published an interim report in 2004 (ATP-'04) that adapted the goals from the ATP-III, based on insights from five trials not included in the original report (2). Two of these trials reaffirmed the ATP-III contention that the minimum acceptable goal for high-risk patients is an ~LDL-C < 100 mg/dL. The ATP-III had also reported that the suggestion by several small studies to lower ~LDL-C to 70–80 mg/dL was even better (1). Two new trials further support lowering ~LDL-C to this level (57,58); accordingly the ATP-'04 supports the tentative goal of ~LDL-C < 70 mg/dL and non-HDL < 100 mg/dL in selected patients at very high risk, recognizing that several pending studies will provide even more insight (2). Unfortunately, neither of the new studies has reported on changes in apoB at this time (57,58), though one did directly measure LDL-C (57). We believe that the continued reliance on LDL-C causes problems of interpretation in populations that have lower LDL-C at baseline. If the approximation unravels with LDL-C at lower levels (12,26,28), and direct techniques are also error prone (14), how can researchers be sure that these biases do not influence their interpretations? Aware of the problems this causes, the ATP in a section of the ATP-'04 report went to great pains to reinterpret one of the studies (57) in an effort to resolve this cognitive dissonance (2). We sympathize, because we also have to negotiate the same analytic contortions to get around the deficiencies of LDL-C. Though we have incorporated the lower ~LDL-C goal into our clinical practice, we submit that if researchers and clinicians are going to delve into this range of LDL levels, it would help also to follow a marker that has more signal and less noise.

We suggest that a practical way to approach hyperlipidemia is first to dichotomize patients into those with isolated ~LDL-C elevations and those with atherogenic dyslipidemia (2). Those with isolated hypercholesterolemia would be managed according to the current ATP-III/ATP-'04 recommendations. Those with atherogenic dyslipidemia would have an additional target of therapy based on some marker of LDL particle number (either apoB or directly measured LDL particle number). Although the superior evidence base and cost favor apoB for this purpose, assessing particle number by the NMR technique is a promising alternative (10). We agree with the Canadian guidelines that a measure of particle number should be an alternative to the primary (i.e., ~LDL-C) goal (4, 41), rather than an alternative to the secondary, non-HDL-C goal (10,28). Linking it to the ATP-III non-HDL-C goal might unnecessarily limit efforts to improve risk detection to those with TGs >200 mg/dL. We have outlined our approach in Fig. 3, which refers to Table 3 for



**Fig. 3.** A New approach to managing high cholesterol. Along with [Table 3](#), our approach reinforces the use of  $\sim$ LDL-C goals by adding some marker of LDL particle number, such as apoB or directly measured LDL particle number. Because isolated elevations of LDL-C are less likely to be associated with an invalid LDL approximation, we typically do not follow the additional marker in this setting. If a patient with an isolated elevation of LDL-C has a condition that invalidates the approximation, then we will do one of two things. The first is to measure LDL-C by  $\beta$ -quantification (because many of the other direct techniques are unreliable). The second is simply to follow the additional marker. In patients with features of atherogenic dyslipidemia, we routinely follow the additional marker along with LDL-C.

specific goals based on the patient's underlying risk. The approach retains the use of  $\sim$ LDL-C but reinforces treatment goals with apoB or LDL particle number in patients with features of atherogenic dyslipidemia, in which  $\sim$ LDL-C is least reliable. A patient with isolated elevations of  $\sim$ LDL-C need not have additional labs, provided that there are no clinical factors that invalidate the approximation ([Table 1](#)).

We believe that incorporating measures of lipoprotein number will overcome the numerous limitations of the LDL approximation, thereby improving the detection of at-risk patients. More important, this approach maintains links to clinical trial evidence by supporting, rather than supplanting, the LDL approximation. This algorithm should capture most of the residual risk related to the other markers discussed herein, except for Lp(a). We typically reserve Lp(a) for patients who have a family history of premature disease but lack a personal history of obvious risk factors. Lp(a) could also be used if the clinician suspects that it constitutes a significant confounder for LDL-C, e.g., in an African-American patient whose LDL-C seems to be unusually resistant to statin therapy.

## CONCLUSION

A number of lipoprotein-related ASCVD risk factors have been proposed to complement the deficiencies of cholesterol-based surrogates. In particular, a growing body of

Table 3  
Proposed Cutoffs for Treatment Goals<sup>a</sup>

	<i>Isolated LDL elevation</i>	<i>Atherogenic dyslipidemia</i>
<i>High risk</i>		
CHD or CHD risk equivalent or FRS ⊕ 20%	LDL-C < 100 mg/dL	LDL-C < 100 mg/dL <sup>b</sup> and either of the following: apoB < 90 mg/dL, LDL particles < 1100 nmol/L
<i>Moderate risk</i>		
⊕2 risk factors or FRS 10–20%	LDL-C < 130 mg/dL	LDL-C < 130 mg/dL <sup>b</sup> and either of the following: apoB < 105 mg/dL, LDL particles < 1400 nmol/L
<i>Low risk</i>		
≤1 risk factor and FRS < 10%	LDL-C < 160 mg/dL	LDL-C < 160 mg/dL and either of the following: apoB < 120 mg/dL, LDL particles < 1800 nmol/L

<sup>a</sup>The NCEP secondary goal does not apply to isolated LDL, because non-HDL is only recommended in the presence of hypertriglyceridemia. non-HDL is not needed when the variable it mimics (i.e., apoB) is used as a target of therapy. LDL-C refers to the cholesterol content of LDL and may be assessed by the Friedewald approximation. LDL particles refer to quantification by NMR spectroscopy (cutoffs determined from the Framingham Offspring Study) (42).

<sup>b</sup>The optional goals identified in the ATP-'04 (2) should apply to the LDL-C goals, but the suggested apoB and LDL particle goals would remain unchanged.

FRS, Framingham Risk Score.

evidence supports incorporating measures of lipoprotein particle number into clinical practice. Although consensus guidelines differ on the clinical practicality of such tests, there is general agreement that the underlying principle is sound. Some recent consensus groups have determined that the evidence for apoB is sufficiently strong to be included in their national guidelines (4,41). We think it is reasonable to augment the ATP-III/ATP-'04 goals to guard against undertreating patients, using either apoB or LDL particle number, especially for those with atherogenic dyslipidemia.

## APPENDIX: CASE STUDY

### *Part I: Initial Evaluation*

RC is a 43-yr-old man who presented without complaints for routine care. His past medical history is notable for seasonal allergic rhinitis and erectile dysfunction but is otherwise unremarkable. He has never smoked and eats a typical Western diet. He has a sedentary job but recently started exercising several days a week. He is concerned that his father died suddenly from an MI at the age of 60; his mother survived a stroke at the age of 68. His medications include fexofenadine as needed for allergies, and sildenafil as needed. He wants to know if he should start taking an aspirin every day.

On examination, RC appears healthy, with a BP of 128/80 mmHg and a heart rate of 102 beats/min. He stands 5 ft, 10 in.; weighs 190 lb; and has a waist circumference is 38 in. The remainder of his examination is unremarkable. Fasting lab work reveals normal electrolytes and a glucose of 106 mg/dL. His total cholesterol is 147 mg/dL, LDL-C is 92 mg/dL, HDL-C is 26 mg/dL, and TGs are 145 mg/dL.

RC's physician tells him that he has one major risk factor for ASCVD (low HDL-C) and reassures him that his Framingham risk score indicates only a 1% chance of having a heart attack over the next 10 yr. His baseline LDL-C is below the goal of <160 mg/dL, and because he does not have high TGs, non-HDL-C is not a target of therapy.

The following questions should be considered:

- Does the LDL cholesterol adequately characterize RC's risk?
- The physician suspected that RC had more risk than projected by the clinical guidelines. What other tests for atherogenic lipoproteins are clinically available that might confirm this suspicion? Would RC benefit from such testing?

### ***Part II: A Follow-Up Visit***

RC returns a year later without new complaints and reports no changes in his health. He brings additional laboratory test results conducted when he participated as a health volunteer in a research study. His cholesterol levels are comparable with the previous values, but the additional test results include an apoB of 135 mg/dL (optimal: <90 mg/dL) and, by NMR technique, an LDL particle number of 2204 nmol/L (optimal: <1100). His LDL is predominately the small, dense variety. His Lp(a) is 6 mg/dL.

RC's apoB and LDL particle number are substantially elevated, consistent with abnormally small, dense LDL. His Lp(a) is normal. Does this additional information contribute to his risk assessment?

### ***Part III: RC Revisited***

At the age of 45, RC survived an MI. A month prior, his total cholesterol was 147 mg/dL, LDL-C was 90 mg/dL, HDL-C was 25 mg/dL, and TGs were 158 mg/dL. Subsequent workup revealed two-vessel coronary disease that did not require revascularization. Although RC's LDL-C was normal, his cardiologist started treatment with lovastatin and extended-release niacin and eventually titrated the dose up to 40 mg of the statin with 1000 mg of niacin. RC also started taking fish oil and a small dose of an angiotensin-converting enzyme inhibitor. On this regimen, his total cholesterol was 132 mg/dL, LDL-C was 80 mg/dL, HDL-C was 34 mg/dL, and TGs were 92 mg/dL. His apoB decreased to 86 mg/dL, and an NMR test confirmed that his LDL particle number had decreased to 1080 nmol/L and that his LDL had converted to a larger size.

### ***Discussion***

At baseline, RC had optimal cholesterol levels, few major risk factors, and a reassuring Framingham score. Yet he had an ominous family history, impaired fasting glucose, and a low HDL-C. The low HDL-C was the only lipid abnormality that suggested he had atherogenic dyslipidemia, but prediabetes is also an important clue. Although the standard labs hinted at subtle abnormalities, the apoB and NMR findings revealed substantial lipoprotein abnormalities that were not reflected in his LDL-C levels. In fact, the "optimal" ~LDL-C might be falsely reassuring. The ATP-III approach helps to overcome this problem by adding criteria for managing hypertriglyceridemia (and, in turn, non-HDL-C) and metabolic syndrome. Many patients with atherogenic dyslipidemia, however, do not meet criteria

for either condition and would still appear to have low risk. A measure of lipoprotein particle number might have confirmed the physician's initial suspicion that RC had additional risk not detected by traditional risk factors.

## REFERENCES

1. The National Cholesterol Education Program (NCEP) Expert Panel. Third Report of the National Cholesterol Education Program (NCEP) Expert Panel on Detection, Evaluation, and Treatment of High Blood Cholesterol in Adults (Adult Treatment Panel III) Final Report. *Circulation* 2002;106(25):3143–3421.
2. Grundy SM, Cleeman JI, Merz CNB, et al. Implications of recent clinical trials for the National Cholesterol Education Program Adult Treatment Panel III Guidelines. *Circulation* 2004;110(2):227–239.
3. De Backer G, Ambrosioni E, Borch-Johnsen K, et al. European guidelines on cardiovascular disease prevention in clinical practice: Third Joint Task Force of European and other Societies on Cardiovascular Disease Prevention in Clinical Practice (constituted by representatives of eight societies and by invited experts). *Eur Heart J* 2003;24(17):1601–1610.
4. Genest J, Frohlich J, Fodor G, McPherson R. Recommendations for the management of dyslipidemia and the prevention of cardiovascular disease: summary of the 2003 update. *CMAJ* 2003;169(9):921–924.
5. Pearson TA, Blair SN, Daniels SR, et al. AHA Guidelines for Primary Prevention of Cardiovascular Disease and Stroke: 2002 Update: Consensus Panel Guide to Comprehensive Risk Reduction for Adult Patients Without Coronary or Other Atherosclerotic Vascular Diseases. American Heart Association Science Advisory and Coordinating Committee. *Circulation* 2002;106(3):388–391.
6. Braunwald E, Antman EM, Beasley JW, et al. ACC/AHA 2002 guideline update for the management of patients with unstable angina and non-ST-segment elevation myocardial infarction—summary article: a report of the American College of Cardiology/American Heart Association task force on practice guidelines (Committee on the Management of Patients with Unstable Angina). *J Am Coll Cardiol* 2002;40(7):1366–1374.
7. American Diabetes Association. Management of dyslipidemia in adults with diabetes. *Diabetes Care* 2003;26:S83–S86.
8. Mosca L, Appel LJ, Benjamin EJ, et al. Evidence-based guidelines for cardiovascular disease prevention in women. *Circulation* 2004;109(5):672–693.
9. Kwiterovich PO Jr. Clinical relevance of the biochemical, metabolic, and genetic factors that influence low-density lipoprotein heterogeneity. *Am J Cardiol* 2002;90(8A):30i–47i.
10. Grundy SM. Approach to lipoprotein management in 2001 National Cholesterol Guidelines. *Am J Cardiol* 2002;90(8 Suppl 1):11–21.
11. Friedewald WT, Levy RI, Fredrickson DS. Estimation of the concentration of low-density lipoprotein cholesterol in plasma, without use of the preparative ultracentrifuge. *Clin Chem* 1972;18(6):499–502.
12. Bachorik PS, Ross JW. National Cholesterol Education Program Recommendations on Lipoprotein Measurement from the National Cholesterol Education Program Working Group on Lipoprotein Measurement. National Heart, Lung, and Blood Institute, Bethesda, MD, 1995.
13. Nauck M, Warnick GR, Rifai N. Methods for measurement of LDL-cholesterol: a critical assessment of direct measurement by homogeneous assays versus calculation. *Clin Chem* 2002;48(2):236–254.
14. Miller WG, Waymack PP, Anderson FP, Ethridge SF, Jayne EC. Performance of four homogeneous direct methods for LDL-cholesterol. *Clin Chem* 2002;48(3):489–498.
15. Sniderman AD, Blank D, Zakarian R, Bergeron J, Frohlich J. Triglycerides and small dense LDL: the twin Achilles heels of the Friedewald formula. *Clin Biochem* 2003;36(7):499–504.
16. Rubies-Prat J, Reverter JL, Senti M, et al. Calculated low-density lipoprotein cholesterol should not be used for management of lipoprotein abnormalities in patients with diabetes mellitus. *Diabetes Care* 1993;16(8):1081–1086.
17. Hirany S, Li D, Jialal I. A more valid measurement of low-density lipoprotein cholesterol in diabetic patients. *Am J Med* 1997;102(1):48–53.
18. Branchi A, Rovellini A, Torri A, Sommariva D. Accuracy of calculated serum low-density lipoprotein cholesterol for the assessment of coronary heart disease risk in NIDDM patients. *Diabetes Care* 1998;21(9):1397–1402.
19. Warnick GR, Knopp RH, Fitzpatrick V, Branson L. Estimating low-density lipoprotein cholesterol by the Friedewald equation is adequate for classifying patients on the basis of nationally recommended cut-points. *Clin Chem* 1990;36(1):15–19.

20. Matas C, Cabre M, La VA, et al. Limitations of the Friedewald formula for estimating low-density lipoprotein cholesterol in alcoholics with liver disease. *Clin Chem* 1994;40(3):404–406.
21. Joven J, Villabona C, Vilella E, Masana L, Alberti R, Valles M. Abnormalities of lipoprotein metabolism in patients with the nephrotic syndrome. *N Engl J Med* 1990;323(9):579–584.
22. Rajman I, Harper L, McPake D, Kendall M, Wheeler D. Low-density lipoprotein subfraction profiles in chronic renal failure. *Nephrol Dialysis Transplant* 1998;13(9):2281–2287.
23. Shoji T, Ishimura E, Inaba M, Tabata T, Nishizawa Y. Atherogenic lipoproteins in end-stage renal disease. *Am J Kidney Dis* 2001;38(4 Suppl 1):S30–S33.
24. Legault C, Stefanick ML, Miller VT, Marcovina SM, Schrott HG. Effect of hormone replacement therapy on the validity of the Friedewald equation in postmenopausal women: the postmenopausal estrogen/progestins interventions (PEPI) trial. *J Clin Epidemiol* 1999;52(12):1187–1195.
25. Gotto AM Jr, Whitney E, Stein EA, et al. Relation between baseline and on-treatment lipid parameters and first acute major coronary events in the Air Force/Texas Coronary Atherosclerosis Prevention Study (AFCAPS/TexCAPS). *Circulation* 2000;101(5):477–484.
26. Scharnagl H, Nauck M, Wieland H, Marz W. The Friedewald formula underestimates LDL cholesterol at low concentrations. *Clin Chem Lab Med* 2001;39(5):426–431.
27. Cui Y, Blumenthal RS, Flaws JA, et al. Non-high-density lipoprotein cholesterol level as a predictor of cardiovascular disease mortality. *Arch Intern Med* 2001;161(11):1413–1419.
28. Grundy SM. Low-density lipoprotein, non-high-density lipoprotein, and apolipoprotein B as targets of lipid-lowering therapy. *Circulation* 2002;106(20):2526–2529.
29. Sniderman AD, St-Pierre AC, Cantin B, Dagenais GR, Despres JP, Lamarche B. Concordance/discordance between plasma apolipoprotein B levels and the cholesterol indexes of atherosclerotic risk. *Am J Cardiol* 2003;91(10):1173–1177.
30. Sattar N, Williams K, Sniderman AD, D'Agostino R Jr, Haffner SM. Comparison of the associations of apolipoprotein B and non-high-density lipoprotein cholesterol with other cardiovascular risk factors in patients with the metabolic syndrome in the Insulin Resistance Atherosclerosis Study. *Circulation* 2004;110(17):2687–2693.
31. Elovson J, Chatterton JE, Bell GT, et al. Plasma very low density lipoproteins contain a single molecule of apolipoprotein B. *J Lipid Res* 1988;29(11):1461–1473.
32. Rader DJ, Hoeg JM, Brewer HB Jr. Quantitation of plasma apolipoproteins in the primary and secondary prevention of coronary artery disease. *Ann Intern Med* 1994;120(12):1012–1025.
33. Marcovina SM, Albers JJ, Kennedy H, Mei JV, Henderson LO, Hannon WH. International Federation of Clinical Chemistry standardization project for measurements of apolipoproteins A-I and B. IV. Comparability of apolipoprotein B values by use of International Reference Material. *Clin Chem* 1994;40(4):586–592.
34. Sniderman AD, Furberg CD, Keech A, et al. Apolipoproteins versus lipids as indices of coronary risk and as targets for statin treatment. *Lancet* 2003;361(9359):777–780.
35. Walldius G, Jungner I. Apolipoprotein B and apolipoprotein A-I: risk indicators of coronary heart disease and targets for lipid-modifying therapy. *J Intern Med* 2004;255(2):188–205.
36. Walldius G, Jungner I, Holme I, Aastveit AH, Kolar W, Steiner E. High apolipoprotein B, low apolipoprotein A-I, and improvement in the prediction of fatal myocardial infarction (AMORIS study): a prospective study. *Lancet* 2001;358(9298):2026–2033.
37. Talmud PJ, Hawe E, Miller GJ, Humphries SE. Nonfasting apolipoprotein B and triglyceride levels as a useful predictor of coronary heart disease risk in middle-aged UK men. *Arterioscl Thromb Vasc Biol* 2002;22(11):1918–1923.
38. Williams K, Sniderman AD, Sattar N, D'Agostino R Jr, Wagenknecht LE, Haffner SM. Comparison of the associations of apolipoprotein B and low-density lipoprotein cholesterol with other cardiovascular risk factors in the Insulin Resistance Atherosclerosis Study (IRAS). *Circulation* 2003;108(19):2312–2316.
39. Downs JR, Clearfield M, Weis S, et al. Primary prevention of acute coronary events with lovastatin in men and women with average cholesterol levels: results of AFCAPS/TexCAPS. *JAMA* 1998;279(20):1615–1622.
40. Pedersen TR, Olsson AG, Faergeman O, et al. Lipoprotein changes and reduction in the incidence of major coronary heart disease events in the Scandinavian Simvastatin Survival Study (4S). *Circulation* 1998;97(15):1453–1460.
41. Leiter LA, Mahon J, Ooi TC, et al. Macrovascular complications, dyslipidemia and hypertension. *Can J Diabetes* 2003;27:S58–S65.
42. Sniderman AD. Applying apoB to the diagnosis and therapy of the atherogenic dyslipoproteinemias: a clinical diagnostic algorithm. *Curr Opin Lipidol* 2004;15(4):433–438.

43. Otvos JD, Jeyarajah EJ, Cromwell WC. Measurement issues related to lipoprotein heterogeneity. *Am J Cardiol* 2002;90(8A):22i–29i.
44. Lahdenpera S, Tilly-Kiesi M, Vuorinen-Markkola H, Kuusi T, Taskinen MR. Effects of gemfibrozil on low-density lipoprotein particle size, density distribution, and composition in patients with type II diabetes. *Diabetes Care* 1993;16(4):584–592.
45. Rubins HB, Robins SJ, Collins D, et al. Gemfibrozil for the secondary prevention of coronary heart disease in men with low levels of high-density lipoprotein cholesterol. Veterans Affairs High-Density Lipoprotein Cholesterol Intervention Trial Study Group. *N Engl J Med* 1999;341(6):410–418.
46. Robins SJ, Collins D, Wittes JT, et al. Relation of gemfibrozil treatment and lipid levels with major coronary events: VA-HIT: a randomized controlled trial. *JAMA* 2001;285(12):1585–1591.
47. Pegus C, Otvos J, Collins D, et al. Gemfibrozil treatment increases LDL size and decreases LDL particle concentration in the Veterans Affairs HDL Intervention Trial. *Circulation* 2002;Suppl (<http://aha.agora.com/abstractviewer>):(abstract 114468).
48. Otvos JD, Collins D, Freedman DS, et al. LDL and HDL particle subclasses are independent predictors of cardiovascular events in the Veteran Affairs HDL Intervention Trial. *Circulation* 2002;Suppl (<http://aha.agora.com/abstractviewer>): (abstract 112626).
49. Kostner KM, Kostner GM. Lipoprotein(a): still an enigma? *Curr Opin Lipidol* 2002;13(4):391–396.
50. Danesh J, Collins R, Peto R. Lipoprotein(a) and coronary heart disease: meta-analysis of prospective studies. *Circulation* 2000;102(10):1082–1085.
51. Luc G, Bard JM, Arveiler D, et al. Lipoprotein (a) as a predictor of coronary heart disease: the PRIME Study. *Atherosclerosis* 2002;163(2):377–384.
52. Ariyo AA, Thach C, Tracy R. Lp(a) lipoprotein, vascular disease, and mortality in the elderly. *N Engl J Med* 2003;349(22):2108–2115.
53. Scanu AM. Lipoprotein(a), Friedewald formula, and NCEP guidelines: National Cholesterol Education Program. *Am J Cardiol* 2001;87(5):608, 609, A9.
54. Guyton JR, Dahlen GH, Patsch W, Kautz JA, Gotto AM Jr. Relationship of plasma lipoprotein Lp(a) levels to race and to apolipoprotein B. *Arteriosclerosis* 1985;5(3):265–272.
55. Moliterno DJ, Jokinen EV, Miserez AR, et al. No association between plasma lipoprotein(a) concentrations and the presence or absence of coronary atherosclerosis in African-Americans. *Arterioscl Thromb Vasc Biol* 1995;15(7):850–855.
56. Goldstein MR. Should we routinely measure lipoprotein(a) in postmenopausal African-American women? *Am J Cardiol* 2001;88(6):719, 720.
57. Heart Protection Study Collaborative Group. MRC/BHF Heart Protection Study of cholesterol lowering with simvastatin in 20,536 high-risk individuals: a randomised placebo-controlled trial. *Lancet* 2002;360(9326):7–22.
58. Cannon CP, Braunwald E, McCabe CH, et al. Comparison of intensive and moderate lipid lowering with statins after acute coronary syndromes. *N Engl J Med* 2004;350:1495–1504.





# 30

---

## Lipoprotein-Associated Phospholipase A<sub>2</sub> and Other Lipid-Related Biomarkers in Cardiovascular Disease

---

*Natalie Khuseyinova, MD  
and Wolfgang Koenig, MD, PhD*

### CONTENTS

INTRODUCTION  
LIPOPROTEIN-ASSOCIATED PHOSPHOLIPASE A<sub>2</sub>  
TYPE II SECRETORY PHOSPHOLIPASE A<sub>2</sub>  
OXIDIZED LDL  
LIPOXYGENASES  
LIPOPROTEIN LIPASE  
ADIPONECTIN  
CONCLUSION  
REFERENCES

---

### SUMMARY

Although an atherogenic lipoprotein phenotype has been well recognized as an important predictor of cardiovascular disease, recent studies have demonstrated a number of additional markers as emerging biomarkers to identify patients at risk for future coronary heart disease. Among them, lipoprotein-associated phospholipase A<sub>2</sub> (Lp-PLA<sub>2</sub>), which is directly involved in the oxidation of low-density lipoprotein (LDL) and further atherosclerotic plaque development, seems to be the most promising and may be added to the clinical armamentarium for improved prediction of cardiovascular disease in the future. This brief overview aims to summarize our current knowledge based on observations from recent experimental and clinical studies, with emphasis on potential pathophysiological mechanisms of action, and on the clinical relevance of L-PLA<sub>2</sub>, as well as other lipid-related biomarkers such as oxidized LDL, type II secretory phospholipase A<sub>2</sub>, lipoxigenases, lipoprotein lipase, and adiponectin.

**Key Words:** Lipid-related biomarkers; inflammation; atherosclerosis; risk prediction; cardiovascular disease.

From: *Contemporary Cardiology:  
Cardiovascular Biomarkers: Pathophysiology and Disease Management*  
Edited by: David A. Morrow © Humana Press Inc., Totowa, NJ

## INTRODUCTION

Although an atherogenic lipoprotein phenotype characterized by increased levels of total cholesterol, low-density lipoprotein, cholesterol (LDL-C), and non-high-density lipoprotein cholesterol (non-HDL-C), and a low concentration of HDL cholesterol has been well recognized as an important predictor of cardiovascular disease (CVD) (*see* Chapter 29), and although most of these lipoproteins have been integrated into various scores for coronary heart disease (CHD) risk assessment (e.g., Framingham Risk Score, PROCAM score, ESC SCORE), studies have now demonstrated a number of additional lipid-related markers such as lipoprotein-associated phospholipase A<sub>2</sub> (Lp-PLA<sub>2</sub>) and oxidized LDL (oxLDL) to be emerging biomarkers that improve the ability to identify patients at risk of future CHD.

This chapter summarizes our current knowledge on lipid-related biomarkers based on observations from experimental and clinical studies, with emphasis on their potential pathophysiological mechanisms of action and on their clinical relevance.

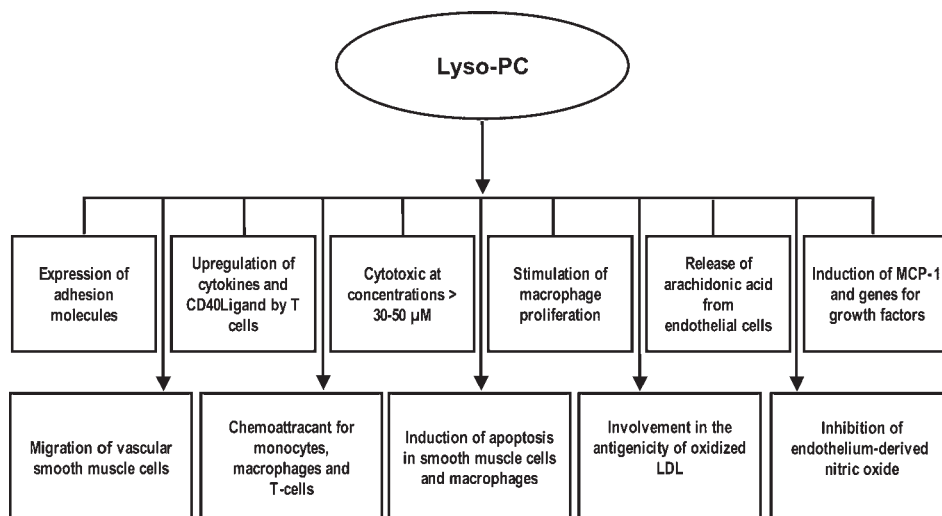
### LIPOPROTEIN-ASSOCIATED PHOSPHOLIPASE A<sub>2</sub>

Lp-PLA<sub>2</sub>, a 45.4-kDa protein, is a calcium-independent member of the phospholipase A<sub>2</sub> family. Two isoforms of this enzyme (intra- and extracellular [secreted] forms) have been described (*1,2*). It is produced mainly by monocytes, macrophages, T-lymphocytes, liver, and mast cells (*3–5*). Lp-PLA<sub>2</sub> activity occurs in association with macrophages and has been found to be upregulated in atherosclerotic lesions, especially in complex plaques (*6*), as well as in the fibrous cap of coronary lesions prone to rupture (*7*). In the bloodstream, two-thirds of the Lp-PLA<sub>2</sub> plasma isoform circulates primarily bound to LDLs; the other third is distributed between HDLs and very low-density lipoproteins (VLDLs) (*8,9*).

#### *Actions of Lp-PLA<sub>2</sub>*

Lp-PLA<sub>2</sub> seems to play a dual role in atherosclerotic disease (*10*). The HDL-associated enzyme is considered to be protective against atherosclerosis, whereas Lp-PLA<sub>2</sub> bound to LDL is probably proatherogenic. Indeed, Lp-PLA<sub>2</sub> was initially denoted as the platelet-activating factor acetylhydrolase (PAF-AH), reflecting its antiatherogenic activity: to catalyze the degradation of PAF (*1*) and related oxidized phospholipids, thereby preventing LDL from further oxidative modification (*11–13*). In addition, the HDL-associated Lp-PLA<sub>2</sub> fraction may also inhibit foam cell formation and enhance cholesterol efflux in macrophages.

On the other hand, Lp-PLA<sub>2</sub> may promote oxidation of LDL (*10,14,15*), and subsequent investigations indeed favored the proatherogenic properties of this enzyme (*16–18*). As mentioned, approx 70% of Lp-PLA<sub>2</sub> in blood resides on LDLs. However, they are not secreted together; rather, after entering the bloodstream, Lp-PLA<sub>2</sub> clings to LDL via the carboxy terminus of apolipoprotein-B (ApoB) (*19*). LDL, therefore, provides a circulating reservoir, in which Lp-PLA<sub>2</sub> remains inactive until LDL undergoes oxidative modification. After LDL oxidation within the arterial wall, a short acyl group at the *sn*-2 position of phospholipids becomes susceptible to the hydrolytic action of Lp-PLA<sub>2</sub> that cleaves an oxidized phosphatidylcholine component of the lipoprotein particle, generating two potent proinflammatory and proatherogenic mediators: lysophosphatidylcholine (Lyso-PC) and oxidized fatty acid (oxFA) (*16*). Of particular note, Lp-PLA<sub>2</sub> acts only on oxidatively modified LDLs, and hydrolysis of oxLDL can be carried out solely by Lp-PLA<sub>2</sub> (*16,17*). Proinflammatory actions of Lyso-PC, as well as those of oxFA, trigger a cascade



**Fig. 1.** Proatherogenic activities of Lyso-PC.

of events, which might directly promote atherogenesis. Lyso-PC is a potent chemoattractant for T-cells and monocytes, promotes endothelial cell (EC) dysfunction, stimulates macrophage proliferation, and induces apoptosis in smooth muscle cells (SMCs) and macrophages (17,20,21) (Fig. 1). Thus, Lp-PLA<sub>2</sub> may represent an important “missing link” between the oxidative modification of LDL in the intimal layer of the arterial wall and local inflammatory processes within the atherosclerotic plaque.

The proatherogenic role of Lp-PLA<sub>2</sub> was also implicated by observations from in vitro studies suggesting that this enzyme is a novel therapeutic target. In fact, azetidinones, a new class of compounds acting as acylating inhibitors of the enzymatic activity of Lp-PLA<sub>2</sub>, have shown the ability to interfere with the biological (toxic) sequelae of oxLDL, i.e., chemoattraction of monocytes and apoptosis in macrophages, although the rate of LDL oxidation was not affected (16,18,22). Decreased accumulation of Lyso-PC and oxFA contents were also seen with this compound. Moreover, experimental studies in Watanabe heritable hyperlipidemic (WHHL) rabbits have shown that inhibition of Lp-PLA<sub>2</sub> leads to a reduction in atherosclerotic lesion formation (17). In addition to azetidinones, another class of compounds, pyrimidones, noncovalent Lp-PLA<sub>2</sub> inhibitors, also prevented the production of Lyso-PC and subsequent monocyte chemotaxis in vitro (18,23). Further in vivo studies revealed a 95% inhibition of Lp-PLA<sub>2</sub> in atherosclerotic plaque from WHHL rabbits, observed 2 h after dosing (30 mg/kg) of SB-480848 (24), thereby identifying this compound as a very potent Lp-PLA<sub>2</sub> inhibitor with a suitable profile for evaluation in humans. Indeed, results from a multicenter trial (25) showed a dose-dependent inhibition of Lp-PLA<sub>2</sub> plasma activity by 52 and 81% compared with placebo after administration of 40 and 80 mg of SB-480848, respectively.

### *Association of Lp-PLA<sub>2</sub> With Cardiovascular Risk*

#### **PROSPECTIVE NESTED CASE–CONTROL STUDIES**

Initial evidence for an association of Lp-PLA<sub>2</sub> with cardiovascular risk came from the West of Scotland Coronary Prevention Study (WOSCOPS), a large primary prevention trial of men at high risk that was primarily initiated to evaluate the effect of pravastatin

therapy on reduction of CHD (26). Of 6595 middle-aged men with hypercholesterolemia and no preexisting CHD, 580 with subsequent coronary events (nonfatal myocardial infarction [MI], CHD death, or coronary revascularization procedure) that occurred during a 4.9-yr follow-up were enrolled as case subjects and compared with 1160 event-free participants, matched for age and smoking. Elevated Lp-PLA<sub>2</sub> concentrations at baseline were associated with an increased risk of subsequent coronary events. The relative risk (RR) associated with an increase of one standard deviation (SD) in Lp-PLA<sub>2</sub> was 1.18 (95% confidence interval [CI]: 1.05–1.33;  $p = 0.005$ ) after controlling for traditional risk factors and was independent of various other biomarkers such as C-reactive protein (CRP), fibrinogen, and white blood cell (WBC) count. By contrast, in similar multivariable analyses, the predictive values for CRP, fibrinogen, and WBC count were substantially attenuated after controlling for traditional risk factors and were no longer statistically significant after adjustment for each of the other inflammatory markers.

The predictive role of Lp-PLA<sub>2</sub> was assessed within the Women's Health Study (WHS), a large cohort of middle-aged normocholesterolemic women (27) representing a low-risk population for CVDs. Using a nested case–control design that included 123 cases and 123 controls, investigators found that baseline concentrations of Lp-PLA<sub>2</sub> were significantly higher among women who subsequently developed cardiovascular events (such as MI, stroke, or death owing to CHD) compared with those who remained free of vascular disease (mean of 1.2 vs 1.05 mg/L, respectively;  $p = 0.016$ ). However, although the RR in the top quartile compared with the bottom quartile was 1.73 (95% CI: 0.87–3.44), it was statistically nonsignificant and decreased further to 1.17 (95% CI: 0.45–3.05) after adjustment for various risk factors. This lack of association could be attributed to existing gender differences for Lp-PLA<sub>2</sub>. Indeed, several studies (28–30) have already reported on lower levels of Lp-PLA<sub>2</sub> in women than in men, and experimental data may offer a possible explanation for these differences. It has been shown that administration of estrogen to rats inhibited secretion of the enzyme by hepatocytes, thereby reducing Lp-PLA<sub>2</sub> levels (31,32). Other investigators have shown a decrease in PAF-AH activity in response to estrogen replacement therapy in postmenopausal women (33). Although the investigators had adjusted for hormonal replacement therapy in multivariable analysis, they found that gender differences nevertheless might represent a main source of confounding in the study by Blake et al.

The Atherosclerosis Risk in Communities (ARIC) study served as the database for another case–cohort study that included 608 men and women with incident CHD who were compared with 740 control subjects randomly drawn from the remaining cohort and followed for 6–8 yr (34). Again, Lp-PLA<sub>2</sub> concentrations at baseline were higher in case subjects than in control subjects. In age- and gender-adjusted analysis, Lp-PLA<sub>2</sub> was associated with an increased risk of CHD (hazard ratio [HR] in the top tertile compared with the bottom tertile was 1.78; 95% CI: 1.33–2.38), but statistical significance was lost after multivariable adjustments. By contrast, CRP was predictive in overall analysis even after controlling for multiple covariables (HR: 1.72; 95% CI: 1.24–2.39 comparing those with a CRP >3.0 mg/L with those with a CRP <1.0 mg/L). However, a significant interaction between Lp-PLA<sub>2</sub> and LDL-C (<130 and ≥130 mg/dL) was found. In subjects with low LDL-C, Lp-PLA<sub>2</sub> significantly and independently predicted CHD (HR: 2.08; 95% CI: 1.20–3.62), suggesting that it could be a useful marker for identifying high-risk patients with relatively normal levels of LDL-C, a group in whom additional markers of risk are clearly needed.

### PROSPECTIVE POPULATION-BASED STUDY

Results from the MONICA (Monitoring of Trends and Determinants in Cardiovascular Disease)-Augsburg cohort study further support the hypothesis that Lp-PLA<sub>2</sub> is independently associated with CHD (35). In this prospective study, the RR for a future coronary event associated with elevated Lp-PLA<sub>2</sub> and with elevated CRP concentrations was directly compared in a cohort of 934 initially healthy middle-aged men with moderately increased total cholesterol who were drawn randomly from the general population in 1984 and followed until 1998. During a 14-yr follow-up, a total of 97 fatal and nonfatal coronary events, including sudden cardiac death, occurred. At baseline, both markers were elevated in subjects with a subsequent event compared with subjects in whom there were no events ( $295 \pm 113$  vs  $263 \pm 79$  ng/mL,  $p < 0.01$  for Lp-PLA<sub>2</sub> and  $2.62 \pm 2.98$  vs  $1.53 \pm 3.11$  mg/L,  $p < 0.001$  for CRP). In a Cox model, an increase of 1 SD in Lp-PLA<sub>2</sub> was strongly and independently related to a first-ever event (HR: 1.23; 95% CI: 1.02–1.47), even after controlling for a variety of potential confounders, including the total cholesterol/HDL-C ratio as the strongest lipoprotein variable. Further inclusion of CRP in the model did not appreciably affect its predictive ability (HR: 1.21; 95% CI: 1.01–1.45). The considerably longer follow-up of 14 yr extends the observations reported from the other studies regarding the time frame within which Lp-PLA<sub>2</sub> might be a useful predictor for future cardiovascular events.

### FURTHER STUDIES

The discussed intriguingly consistent results have generated much interest in better defining the relationship between Lp-PLA<sub>2</sub> and cardiovascular risk; Table 1 summarizes data from studies published so far, as well as preliminary data from several subsequent studies (8,26,27,34–43). For instance, in the setting of patients with manifest CHD, a cohort of consecutive patients undergoing coronary angiography was followed for an average of 4 yr, and Lp-PLA<sub>2</sub> was found to represent an independent predictor of subsequent risk of CVD (36). Iribarren et al. (37) demonstrated an association between Lp-PLA<sub>2</sub> mass and coronary artery calcification in young adults. In addition, Oei et al. (38) recently reported preliminary findings from the Rotterdam Study, a cohort of 7983 subjects age 55 yr and above. Multivariable Cox proportional hazard modeling showed an adjusted HR of 1.77 (95% CI: 1.19–2.64) for the top quartile of the Lp-PLA<sub>2</sub> activity compared with the bottom quartile. The investigators further demonstrated that elevated levels of Lp-PLA<sub>2</sub> were significantly associated with an increased risk of stroke. Participants with the highest Lp-PLA<sub>2</sub> levels (Q4) had a 75% increased risk of stroke (HR: 1.75; 95% CI: 1.08–2.84) compared with participants with the lowest levels (Q1) of Lp-PLA<sub>2</sub>. These findings were consistent with preliminary data from the ARIC cohort, in which the relationship among Lp-PLA<sub>2</sub>, CRP, and the incidence of stroke was studied in 223 case subjects who were compared with a random sample cohort of 766 individuals who remained free of disease during a 6-yr follow-up (39). The risk of stroke for individuals with the highest levels of Lp-PLA<sub>2</sub> was twice as high as that for individuals with the lowest levels (HR: 2.04; 95% CI: 1.23–3.38, Q4 vs Q1;  $p < 0.01$ ), even after taking into account other confounders, including lipid variables and CRP. By contrast, LDL-C concentrations did not predict the risk of stroke.

#### *Use of Lp-PLA<sub>2</sub> in Conjunction With CRP*

In several of the above-mentioned studies (34,35,39), the potential additive value of Lp-PLA<sub>2</sub> to CRP in predicting risk was evaluated for CHD and stroke. For this purpose,

Table 1  
Overview of Studies of Lp-PLA<sub>2</sub> and CHD and Stroke<sup>a</sup>

Author	Study	Design	Population	Outcome variable	FU	n	RR/OR	Reference
Prospective studies (CHD)								
Packard et al. <sup>b</sup>	WOSCOPS	Nested case-control	Hyperlipidemic men	Coronary events	4.9	580/1160	1.18 (1.05–1.33) <sup>d</sup>	26
Blake et al. <sup>b</sup>	WHS	Nested case-control	Healthy women	Coronary events	3	123/123	1.17 (0.45–3.05) <sup>e</sup>	27
Ballantyne et al. <sup>b</sup>	ARIC	Nested case-cohort	Healthy M/F	CV events	6–8	608/740	1.15 (0.81–1.63) <sup>c</sup> ; LDL-C < 130 mg/dL 2.08 (1.20–3.62) <sup>f</sup>	34
Koenig et al. <sup>b</sup>	MONICA	Complete cohort	Healthy men	Coronary events	14	934	1.21 (1.01–1.45) <sup>d</sup>	35
Brilakis et al. <sup>b</sup>	Mayo	Complete cohort	CHD patients	CV events	4	504	1.30 (1.06–1.59) <sup>d</sup>	36
Oei et al. <sup>a</sup>	Rotterdam	Nested case-cohort	Elderly (55+)	Coronary events	10	377/1822	1.76 (1.09–2.85) <sup>e</sup>	38
Prospective studies (stroke)								
Oei et al. <sup>c</sup>	Rotterdam	Nested case-cohort	Elderly (55+)	Stroke	12	200/1822	1.77 (1.19–2.64) <sup>e</sup>	38
Ballantyne et al. <sup>b</sup>	ARIC	Nested case-cohort	Healthy M/F	Stroke	6–8	223/766	2.04 (1.23–3.38) <sup>f</sup>	39
Cross-sectional studies (CHD)								
Caslake et al. <sup>b</sup>	Glasgow	Case-control	CHD/control	Presence of CHD	—	94/54	NA	8
Shohet et al. <sup>c</sup>	Dallas	Case-control	CHD/control	Presence of CHD	—	72/72	NA	40
Blankenberg et al. <sup>c</sup>	Mainz	Case-control	CHD/control	Presence of CHD	—	496/477	1.8 (1.01–3.20) <sup>e</sup>	41
Winkler et al. <sup>c</sup>	Freiburg	Case-control	T2DM/control	Presence of CHD	—	42/47	2.09 (1.02–4.29) <sup>e</sup>	42
Khuseynova et al. <sup>b</sup>	Ulm	Case-control	CHD/blood donors	Presence of CHD	—	312/479	1.91 (1.12–3.28) <sup>e</sup>	43
Cross-sectional studies (CAC)								
Iribarren et al. <sup>b,c</sup>	CARDIA	Nested case-control	Young adults	CAC	—	266/266	1.28 (1.03–1.66) <sup>b,d</sup> 1.09 (0.84–1.42) <sup>c,d</sup>	37

<sup>a</sup>CV, cardiovascular; CAC, coronary artery calcification; NA, not assessed; T2DM, type 2 diabetes mellitus.

<sup>b</sup>Measurement of Lp-PLA<sub>2</sub> mass.

<sup>c</sup>Measurement of Lp-PLA<sub>2</sub> activity.

<sup>d</sup>Increase in Lp-PLA<sub>2</sub> per 1 SD in multivariable analyses including CRP.

<sup>e</sup>Quartile analysis, multivariable adjustment.

<sup>f</sup>Tertile analysis, multivariable including CRP.

FU, follow-up; CARDIA, Coronary Artery Risk Development in Young Adults.

high CRP was defined according to a recent American Heart Association/Centers for Disease Control consensus document as  $>3.0$  mg/L, and for Lp-PLA<sub>2</sub> the upper tertile cut point was used (422  $\mu$ g/L in ARIC and 290.8 ng/mL in MONICA). In ARIC, individuals with high Lp-PLA<sub>2</sub> and high CRP exhibited the greatest risk of CHD (HR: 2.95; 95% CI: 1.47–5.94) (34). The MONICA-Augsburg study demonstrated that the combination of elevated Lp-PLA<sub>2</sub> and elevated CRP was consistently associated with a statistically significantly increased risk for future coronary events and was superior to either marker alone in predicting risk (HR: 1.93; 95% CI: 1.09–3.40) compared with both markers not being increased (referent) in the fully adjusted model (35). Examination of stroke in ARIC revealed that individuals with the highest levels of both Lp-PLA<sub>2</sub> and CRP had a greater than eightfold (HR: 8.66; 95% CI: 3.01–24.92) increased risk of stroke compared with those with the lowest levels of both Lp-PLA<sub>2</sub> and CRP (39). Taken together, these data suggest that Lp-PLA<sub>2</sub> and CRP may be complementary (or additive) in identifying high-risk subjects and, therefore, the combination of both markers may further improve risk assessment.

### *Assay for Lp-PLA<sub>2</sub>*

The PLAC<sup>TM</sup> test for the direct measurement of Lp-PLA<sub>2</sub> mass in human plasma, used in most of the studies discussed here, was cleared by the US Food and Drug Administration in July 2003 to aid in the prediction of an individual's risk of a CHD event in conjunction with clinical evaluation and patient risk assessment and represents a precise and reproducible simple blood test.

The PLAC test for Lp-PLA<sub>2</sub> is a simple enzyme-linked immunosorbent assay (ELISA) (a solid-phase enzyme-linked immunosorbent assay) that comprises two specific monoclonal antibodies to the enzyme and is standardized to a recombinant form of Lp-PLA<sub>2</sub> in a calibrator curve. The test requires only 10  $\mu$ L of sample and can be run with serum or plasma samples (heparin or EDTA-anticoagulants) in  $<3$  h to results. No special equipment is required except for a standard ELISA 96-well microplate reader. Blood samples should be refrigerated after processing and for long-term storage should be kept frozen. There are no restrictions to the time of day that the sample should be drawn and no dietary restrictions. In contrast to other emerging risk markers, a very minimal biological variation in Lp-PLA<sub>2</sub> concentrations has been demonstrated among individuals monitored serially over several weeks (44). In addition, Lp-PLA<sub>2</sub> levels are typically unaffected by conditions of systemic inflammation, such as osteoarthritis and chronic obstructive pulmonary disease, whereas markers of inflammatory response are often elevated by these conditions. The normal population medians for men and women are in the range of 230–250 ng/mL, and a value of  $>300$  ng/mL may be considered elevated (demonstrated in the ARIC study, in which the second tertile of the population, at just above 300 ng/mL, had significantly increased risk) (34).

The PLAC test is most suitably performed in patients with an intermediate risk of CHD (by Framingham score or other methods of risk stratification). It has also been recommended that the PLAC test be run in conjunction with all the traditional risk factors (e.g., lipid panels), adding information about risk of CHD even above and beyond CRP.

There have been a number of reports on Lp-PLA<sub>2</sub> using various methods of measuring the enzyme's activity. The most common method has been to measure the release of a radioactive isotopic label from a tritiated PAF substrate, although other methods have been reported. In one study that compared the method of measuring mass of the enzyme (PLAC test) with Lp-PLA<sub>2</sub> activity assay side by side, both methods were associated with



coronary calcium score in young individuals, but only the method of measuring the enzyme mass (PLAC immunoassay) maintained association after full adjustment for other risk factors (37). It should be noted that the preponderance of evidence to date demonstrating the clinical utility of measuring Lp-PLA<sub>2</sub> levels (26,34,35) has been achieved with the PLAC test. There is an imperfect correlation between mass-based and activity-based measurements of Lp-PLA<sub>2</sub>, so it is difficult to predict whether these two approaches will be equivalent or possibly complementary in predicting CHD risk.

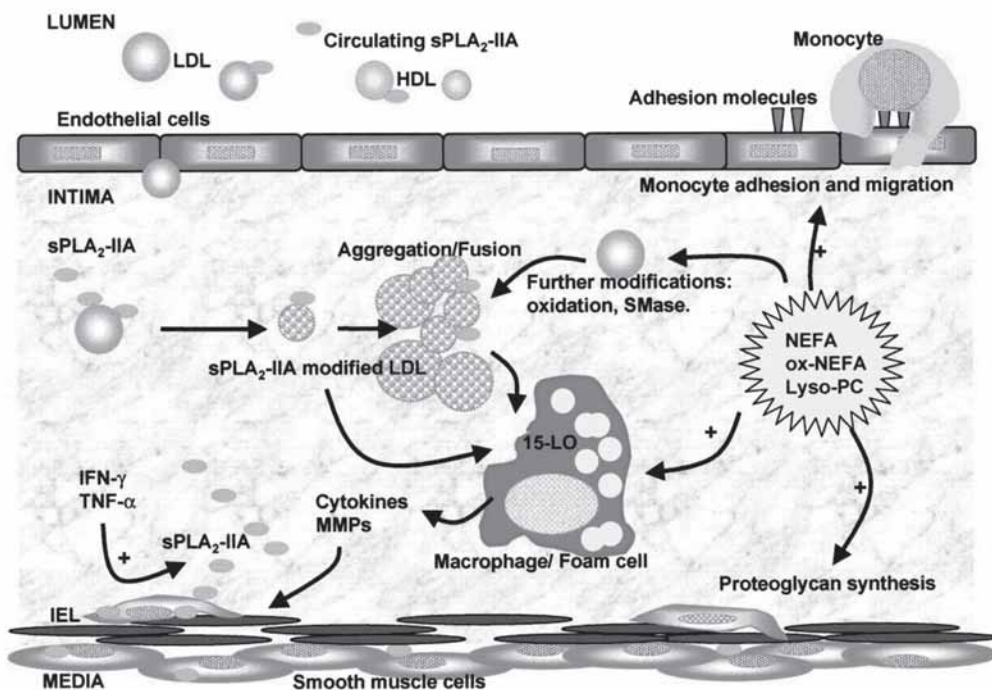
### ***Impact of Lipid-Lowering Agents on Lp-PLA<sub>2</sub>***

Elevated levels of Lp-PLA<sub>2</sub> may respond to a more aggressive approach to global risk reduction. This may include lifestyle modifications as well as drug therapy. A number of clinical studies were able to show that 3-hydroxy-3-methylglutaryl coenzyme A reductase inhibitors (statins) have a most pronounced effect on Lp-PLA<sub>2</sub> plasma level, mainly owing to reduction in LDL-C, and that this effect remained strong and consistent in various populations. Indeed, in patients with type IIa and IIb hyperlipidemia, treatment with atorvastatin resulted in the lowering of Lp-PLA<sub>2</sub> activity by 28–42% (45). In WOSCOPS, the use of pravastatin for 1 yr reduced Lp-PLA<sub>2</sub> mass and activity by 17% (10). In patients with type 2 diabetes mellitus treated with fluvastatin, a 22.8% decrease in Lp-PLA<sub>2</sub> (PAF-AH) activity has also been demonstrated, compared to an increase of 0.4% in the placebo group ( $p < 0.001$ ) (42). Furthermore, recently presented results from the Pravastatin Inflammation/CRP Study, which included 481 subjects free of CVD, showed a reduction in Lp-PLA<sub>2</sub> mass by 22.1% after 12 wk of treatment ( $n = 246$ ) vs only a 7.8% decrease in the placebo group ( $n = 235$ ;  $p < 0.001$ ) (46). In addition to statins, fibrates, another group of widely used lipid-regulating compounds, could also modify plasma level of Lp-PLA<sub>2</sub>. In essence, treatment with fenofibrate resulted in a decrease in Lp-PLA<sub>2</sub> activity in patients with type IIA, IIB and IV dyslipidemias, whereas increased HDL-associated Lp-PLA<sub>2</sub> was found only in patients with combined hyperlipidemia (type IIB) and primary hypertriglyceridemia (type IV) (47). It should also be noted that statins exert no effects on Lp-PLA<sub>2</sub> bound on HDL (45). Taken together, these data provide strong evidence that currently available lipid-lowering drugs may be useful in lowering Lp-PLA<sub>2</sub> plasma concentration.

In summary, a growing body of evidence from large prospective epidemiological, population-based, and clinical studies suggests that Lp-PLA<sub>2</sub> may be an independent and clinically relevant marker for CHD and probably also for stroke. Moreover, since specific inhibitors of Lp-PLA<sub>2</sub> are currently under evaluation in clinical trials, lowering Lp-PLA<sub>2</sub> in plasma and/or the vessel wall might represent a promising novel strategy for the treatment of atherosclerosis via direct targeting of vascular inflammation and, thus, may open a new avenue to combat this widespread disease.

### **TYPE II SECRETORY PHOSPHOLIPASE A<sub>2</sub>**

Type II secretory phospholipase (sPLA<sub>2</sub>-II) is another well-studied member of the phospholipase 2 family. The sPLA<sub>2</sub> family consists of a type I enzyme secreted by the pancreas (so-called pancreatic PLA<sub>2</sub>) and a type II PLA<sub>2</sub> with wide tissue expression (hepatocytes, macrophages, endothelial cells, platelets, and vascular SMCs [VSMCs]) (48,49). sPLA<sub>2</sub>-II is a Ca<sup>2+</sup>-dependent, 14-kDa enzyme that belongs to the group of acute-phase reactants. Circulating levels of sPLA<sub>2</sub>-II increase greatly during systemic inflammatory conditions, such as during sepsis, rheumatoid arthritis, or inflammatory bowel disease (50). Moreover, sPLA<sub>2</sub>-II production is upregulated in response to proinflammatory compounds such



**Fig. 2.** Proatherogenic mechanisms of sPLA<sub>2</sub>-IIA. ApoB-containing lipoproteins and sPLA<sub>2</sub>-IIA, through their interaction with arterial proteoglycans, may facilitate enzymatic hydrolysis of lipoprotein phospholipids. Nonesterified fatty acids (NEFAs), oxidized NEFAs, and lysophosphatidylcholine (Lyso-PC) bind albumin or remain associated with modified lipoproteins. This can induce aggregation and fusion of the lipoproteins, processes that are enhanced by intima proteoglycans. sPLA<sub>2</sub>-IIA-modified LDL can be further modified by sphingomyelinase (SMase) and 15-lipoxygenase (15-LO). NEFAs, oxidized NEFAs, and Lyso-PC may induce proinflammatory cellular processes, such as expression of adhesion molecules by endothelial cells, monocyte migration, and differentiation into macrophages, thereby increasing secretion of proteoglycans by SMCs. Local release of cytokines can stimulate the synthesis and secretion of sPLA<sub>2</sub>-IIA. MMPs, matrix metalloproteinases; IEL, internal elastic lamina. (Reproduced from ref. 52 with permission from Lippincott Williams & Wilkins, Copyright 2004.)

as interleukin (IL)-1 $\beta$ , IL-6, tumor necrosis factor (TNF)- $\alpha$ , interferon (IFN)- $\gamma$ , and oxLDL (50–53).

### Action of sPLA<sub>2</sub>

The catalytic function of sPLA<sub>2</sub> is related to hydrolysis of the *sn*-2 acyl group of glycerophospholipids with further liberation of fatty acids and lysophospholipids, all playing an important role in the biosynthesis of lipid mediators such as PAF, leukotrienes (LTs), prostaglandins, and eicosanoids (54,55). However, in contrast to Lp-PLA<sub>2</sub>, sPLA<sub>2</sub>-II can also hydrolyze unmodified phospholipids. In addition, an antibacterial role of sPLA<sub>2</sub>, owing to degradation of phospholipids in the lipid membrane of Gram-positive infectious agents, is also possible (56,57).

Figure 2 illustrates possible atherogenic mechanisms of sPLA<sub>2</sub>-II. The effect of sPLA<sub>2</sub>-II on lipoproteins results in the release of various lipid mediators at the site of lipoprotein retention in the arterial wall that, in turn, may trigger local inflammatory cellular responses. Furthermore, in arterial tissue, sPLA<sub>2</sub>-II may also directly modify LDL particles to become

more atherogenic, thereby making sPLA<sub>2</sub>-II-treated lipoproteins more susceptible to further lipid oxidation and enzymatic modification (52). In addition, sPLA<sub>2</sub>-II may potentiate the binding and retention of LDL by increasing the affinity of ApoB-100 on LDL to glycosaminoglycans and proteoglycans (58,59). sPLA<sub>2</sub>-II is also implicated in the production of isoprostanes, which exhibit strong mitogenic activity and induce platelet aggregation and vasoconstriction (60). In vivo studies of transgenic mice overexpressing human sPLA<sub>2</sub>-II showed an enhanced formation of bioactive oxidized phospholipids, as well as an increased formation of atherosclerotic lesions (61,62).

### *Association of sPLA<sub>2</sub>-II With Cardiovascular Risk*

The concentration of circulating sPLA<sub>2</sub>-II in blood has been demonstrated to predict coronary events. Among 142 consecutive patients with angiographically proven, stable coronary artery disease (CAD) and 93 control subjects, significantly higher sPLA<sub>2</sub>-II levels were seen in case patients compared with control subjects (63). A strong and positive correlation between sPLA<sub>2</sub>-II and CRP was also observed ( $r = 0.53$ ). Furthermore, patients with CAD were followed for a mean duration of 17.2 mo, during which 48 coronary events occurred. Kaplan-Meier analysis as well as Cox models revealed that subjects with higher levels of sPLA<sub>2</sub>-II (>366 ng/dL) had a significantly higher risk of developing future coronary events such as coronary revascularization, MI, and coronary death than those with the lowest concentration ( $\leq 246$  ng/dL). This prognostic value of sPLA<sub>2</sub>-II was independent of traditional cardiovascular risk factors and various biochemical markers, including CRP (odds ratio [OR]: 3.3; 95% CI, 1.3–9.2;  $p = 0.01$ ) (59). Elevated levels of sPLA<sub>2</sub>-II were significant and independent predictors of future cardiovascular events in patients with CHD after percutaneous coronary intervention (64) and in patients with unstable angina (65). Increased concentrations of sPLA<sub>2</sub>-II might also be important in the prediction of systemic endothelial dysfunction. In patients with chronic CHD, increased concentrations of the enzyme were found to be associated with impaired endothelium-dependent vasodilator function (66). Although consistent, all of these studies were relatively small. In addition, so far no studies have been conducted in initially healthy subjects. Thus, to evaluate further the usefulness of sPLA<sub>2</sub>-II in the prediction of CHD, large prospective studies are needed.

### OXIDIZED LDL

The primary events in the pathogenesis of atherosclerosis are the accumulation and subsequent modification of LDL in the subendothelial matrix. To become atherogenic, trapped native LDL particles undergo modification, including lipolysis, proteolysis, glycation, or aggregation. However, the oxidative modification hypothesis proposes that the most significant event in early lesion formation is lipid oxidation, placing oxLDL in a central role for atherogenesis (67). Indeed, the diverse pathological properties of oxLDL seem to depend on the extent of its modification, which can range from minimal (or minimally modified LDL [mmLDL]) to extensive oxidation (or highly oxLDL) (68). mmLDL, which is still recognized by the LDL receptors, stimulates ECs to produce cellular adhesion molecules such as intercellular adhesion molecule-1 (ICAM-1), vascular adhesion molecule-1 (VCAM-1), E-selectin, monocyte chemoattractant protein-1 (MCP-1), and macrophage colony-stimulating factor (M-CSF) (69,70), resulting in the adhesion of monocytes to the endothelium and subsequent recruitment into the vessel wall. By releasing M-CSF from ECs, mmLDLs also favor monocyte proliferation and differentiation into tissue

Table 2  
Proatherogenic Properties of oxLDL

<i>Biological effect</i>	<i>Possible mechanism</i>
Foam cell formation	Direct uptake of cholesterol by scavenger receptors as well as inhibition of their export from macrophages
Chemoattraction of monocytes, T-lymphocytes	Increased expression of MCP-1 and direct chemotactic effect
Macrophage trapping within intima	Inhibition of motility of macrophages
Impaired vascular function (vasoconstrictor effect)	Inhibition of nitric oxide release or function
Adhesion of monocytes to endothelium	Increased expression of adhesion molecules
Plaque rupture	Enhanced formation of matrix metalloproteinases
Cell proliferation	Induction of growth factors
Thrombogenesis	Promotion of platelet aggregation and increased tissue factor activity
Increased cellular death	Induction of Fas-mediated apoptosis
Induction of proinflammatory genes	Activation of nuclear factor- $\kappa$ B
Increased antigenicity	Induction of autoantibody (IgG) formation

macrophages, a critical step that could be responsible in turn for converting mmLDL into intensively modified oxLDL. Further oxidation also involves several enzymes such as lipoxygenase, myeloperoxidase, secretory phospholipase, and lipoxygenase, the latter being most critical for the oxidation of LDL. oxLDL has a large number of biological actions and consequences, including injury of ECs, expression of adhesion molecules, recruitment and retaining of leukocytes, as well as formation of foam cell and thrombus (71). Table 2 summarizes proatherogenic properties of oxLDL.

### *Association of oxLDL With Cardiovascular Risk*

#### **CROSS-SECTIONAL STUDIES**

To date, a number of cross-sectional studies have examined the involvement of oxidative modification of LDL in subjects with clinical evidence of CVD. Clinical studies (72, 73) have demonstrated that patients with both stable CHD and acute coronary syndrome (ACS) have elevated plasma levels of oxLDL compared with apparently healthy control subjects. A positive association between oxLDL and severity of ACS was found by Ehara et al. (74), who reported that oxLDL concentrations were significantly higher in patients with MI than in patients with unstable or stable angina pectoris or age-matched control subjects. Findings from other studies suggest that plasma levels of oxLDL represent a more sensitive marker for the presence of CAD than the Global Risk Assessment Score (75), and that oxLDL also correlates with the extent of CAD in heart transplant recipients (76). Moreover, circulating oxLDL has been associated with subclinical atherosclerosis in asymptomatic subjects (77,78).

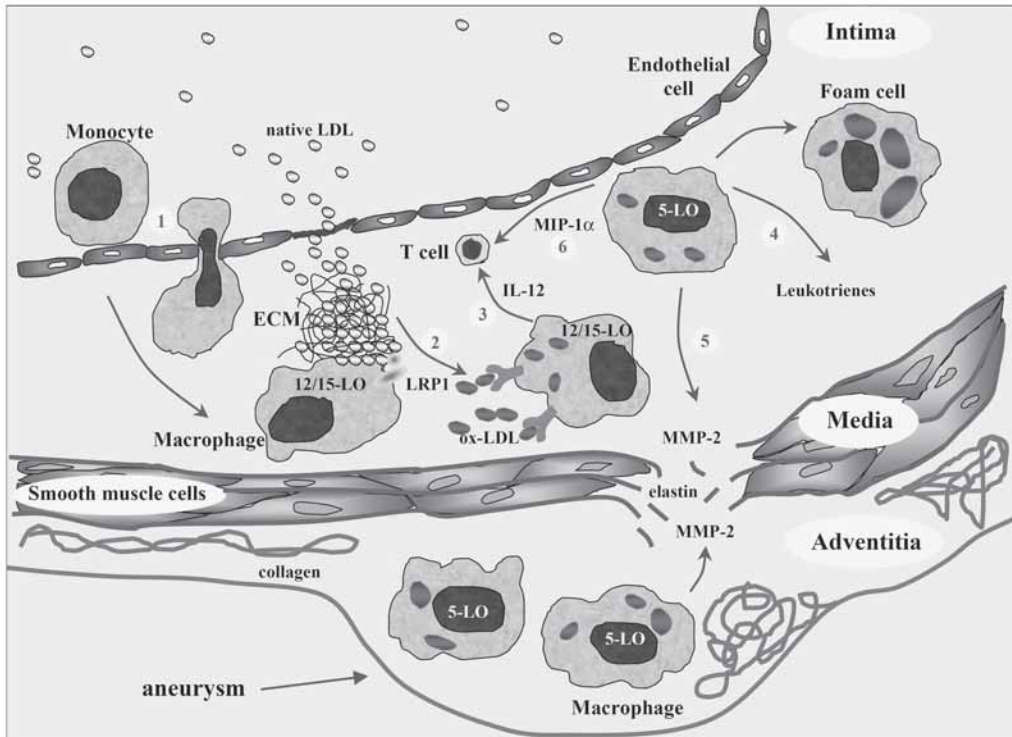
#### **PROSPECTIVE STUDIES**

In 1992, Salonen et al. (79) were the first to conduct a prospective, population-based, nested case-control study in which the titer of autoantibodies to malondialdehyde-modified

LDL and native LDL in baseline serum samples from 30 Finnish men with accelerated progression of carotid atherosclerosis was compared with that of 30 age-matched control subjects without progression during a follow-up of 2 yr. They found the titer of autoantibodies to oxLDL to be an independent predictor for the progression of carotid atherosclerosis. Since then, only one small prospective nested case–control study has demonstrated that oxLDL concentrations might be associated with acute MI (80). During a follow-up of 2.6 yr, 26 case subjects and 26 matched control subjects and a further 26 control subjects with LDL > 5.0 mmol/L were studied. The oxLDL/plasma cholesterol ratio was higher among case subjects compared with control subjects and also higher compared with hypercholesterolemic subjects free of an event, suggesting that the high plasma oxLDL/total cholesterol ratio might serve as a possible indicator of increased risk of MI. Results of another nested case–control study conducted within two population-based MONICA/KORA Augsburg surveys have been presented (81). The association between plasma oxLDL and risk of acute CHD was investigated in 88 men age 45–74 with an incident CHD event and 258 age-matched control subjects during a mean follow-up of 5.6 yr. Baseline mean plasma oxLDL concentrations were significantly higher in case subjects than in control subjects ( $109.8 \pm 32.1$  vs  $92.8 \pm 28.1$  U/L;  $p \leq 0.001$ ). After adjustment for smoking, hypertension, obesity, physical activity, education, and alcohol consumption, the HR for a future CHD event when comparing the top tertile of the oxLDL distribution with the bottom tertile was 4.25 (95% CI: 2.09–8.63;  $p < 0.001$ ). Plasma oxLDL was the strongest predictor of CHD events compared with a conventional lipoprotein profile and with other traditional risk factors for CHD. When both oxLDL and CRP were simultaneously assessed in the same model, they still independently predicted future CHD events even after multivariable adjustment.

### *Impact of Antioxidant Therapy*

Because lipoprotein oxidation is thought to play a major role in atherogenesis, it could be expected that intervention with antioxidants would be protective against atherosclerotic disease. Although antioxidant studies in four different animal models of atherosclerosis (rabbit, mouse, hamster, and monkey) mainly showed positive results (67,82), several large-scale, double-blind, placebo-controlled trials evaluating the effects of different antioxidant compounds on cardiovascular outcome were inconsistent. For instance, two large primary prevention studies, the ATBC Study (Alpha-Tocopherol, Beta-Carotene Cancer Prevention Study) (83) and the PPP (Collaborative Group of the Primary Prevention Project) (84), reported that vitamin E treatment had no apparent effect on MI, CVD, or stroke. The Cambridge Heart Antioxidant Study trial, which included 2002 patients with angiographically confirmed CAD, showed a significant reduction in composite end point (i.e., cardiovascular death and nonfatal AMI), with no effects on total mortality, mortality from CVD, and other causes (85). However, the Grupo Italiano per lo Studio della Sopravvivenza nell'Infarto miocardico Prevenzione Investigators (GISSI) and Heart Outcomes Prevention Evaluation (HOPE) trials, which included a large number of patients with MI or subjects at high risk of cardiovascular events found no benefits of antioxidant supplementation (86,87). A meta-analysis of 15 randomized trials revealed no benefit of antioxidant supplementation on CVD end points (88). Nevertheless, in extremely high-risk patients with renal insufficiency requiring chronic dialysis, supplementation with vitamin E appears to be associated with a significant decrease in cardiovascular end points (MI, stroke, peripheral vascular disease, and unstable angina) (89).



**Fig. 3.** Illustration of various steps that 12/15-LO and 5-LO may participate in throughout atherogenesis and aneurysm formation. 12/15-LO affects monocyte-endothelial interactions, possibly through products of 12/15-LO. 12/15-LO in macrophages participates in oxidative modification of aggregated LDL, bound to extracellular matrix (ECM) potentially via an LDL receptor-related protein 1 (LRP1)-mediated selective uptake of cholesteryl esters. 12/15-LO modulates Th1 cytokine interleukin-12 (IL-12) production in macrophages. 5-LO converts arachidonic acid into LTs, which are potent pro-inflammatory lipid mediators. 5-LO may play a role in regulating matrix metalloproteinase 2 (MMP-2), which breaks down the elastic lamina of the vascular wall and can lead to aneurysm formation. The 5-LO pathway may be important for inflammatory chemokine macrophage inflammatory protein 1- $\alpha$  (MIP-1 $\alpha$ ) production in macrophages. (Reprinted from ref. 91 with permission from Elsevier, Copyright 2004.)

Although the results of large antioxidant trials were disappointing, on the basis of experimental and epidemiological studies, it seems justified to conclude that oxLDL may indeed play a key role in the generation of inflammatory processes in atherosclerotic lesions. This is supported by a recent prospective study showing that increased antioxidative capacity as assessed by glutathione peroxidase 1 levels was associated with improved outcome (90).

### LIPOXYGENASES

Lipoxygenases (LOs) are nonheme, iron-containing dioxygenases that have been implicated in atherogenesis in two ways: (1) by mediating the oxidative modification of LDL and/or (2) through biosynthesis of proinflammatory leukotrienes (LTs) (Fig. 3) (91,92). LOs comprise a family of enzymes classified as 5-, 8-, 12-, and 15-LO according to the oxygenation of the corresponding carbon position of their common fatty acid substrate, arachidonic acid. Among them, only 12/15-LO (15-LO type 1 in human and its mouse ortholog 12/15-LO) as well as 5-LO appear to be prime candidates in the pathogenesis of atherosclerosis.

### *12/15-Lipoxygenase*

Indeed, a key event in early lesion initiation, LDL oxidation, has been linked to the enzymatic action of 12/15-LO. 12/15-LO converts arachidonate (a polyunsaturated fatty acid found in highest concentration in LDL) into bioactive lipid hydroperoxides such as 12/15-hydro(peroxy)eicosatetraenoic (12/15-H[P]ETE) acid and thereby into oxLDL.

Tissue expression of 12/15-LO is well characterized in reticulocytes, platelets, eosinophils, airway epithelial cells, and monocytes/macrophages. The enzyme was also found in macrophage-rich areas of atherosclerotic plaques, colocalizing with oxidation epitopes of modified LDL (93). Monocyte-macrophages represent the key cells that express LO in atherosclerotic lesions.

There is some still controversial evidence for a proatherogenic role of 12/15-LO in animal models of atherosclerosis. For instance, disruption of the 12/15-LO gene in both Apo E- and LDL-receptor null mice significantly reduced the development of atherosclerosis in vivo (94–97). Conversely, overexpression of the 12/15-LO gene in the endothelium was associated with accelerated atherosclerosis (98,99). By contrast, in 12/15-LO-transgenic rabbits, overexpression of the enzyme in macrophages was protective against atherosclerosis (100). However, it has also been demonstrated that specific pharmacological inhibition of 15-LO in rabbits significantly reduced atherosclerosis (101,102).

### *5-Lipoxygenase*

Another member of the LO pathway, 5-LO, may contribute to atherosclerosis by offering the biosynthesis of LTs, which have been identified as mediators of a variety of inflammatory conditions (103).

On the action of secretory or cytoplasmic PLA<sub>2</sub>, arachidonic acid is released from membrane phospholipids and can then be catalyzed by cyclooxygenase to produce various prostaglandins, or it can be transformed by 5-LO to LTs. The first step in the 5-LO metabolic cascade, the transfer of arachidonate to the enzyme, is mediated by an associated protein called 5-LO-activating protein (FLAP) (104–106). 5-LO then oxidizes arachidonic acid, thereby liberating 5-HETE and 5-HPETE, which are subsequently metabolized to LTA<sub>4</sub>. Through several pathways (107), LTA<sub>4</sub> can be further transformed into cysteinyl LTs, namely in C<sub>4</sub>, D<sub>4</sub>, and E<sub>4</sub>, all of which are key players in the pathophysiology of asthma (108), or, even more important, in atherogenesis into LTB<sub>4</sub>. Among several LTB<sub>4</sub> properties, chemotaxis and adhesion of mononuclear cells to the vascular endothelium are most relevant in this context (109,110). LTs might also increase vascular permeability, contribute to monocyte infiltration into atherosclerotic lesions, stimulate SMC proliferation, and induce cytokine secretion (111). In addition, high numbers of 5-LO-expressing cells are found in advanced atherosclerotic lesions in regions that are most prone to rupture (112).

More recently, interest has been focused on the 5-LO gene. Dwyer et al. (113) determined the number of tandem Sp1 binding motifs (5'GGGCGG3') in the 5-LO (*ALOX5*) promoter and investigated their association with the degree of atherosclerosis in the posterior wall of the common carotid arteries. Among 470 healthy, middle-aged subjects enrolled in the Los Angeles Atherosclerosis Study, 6% were identified as carriers of two variant alleles (either more or fewer than five repeats). It has been further shown that carotid artery intimal-media thickness (IMT) was greater in the group with a 5-LO promoter variant compared with carriers of the common allele (736 ± 141 vs 661 ± 95 μm, respectively; *p* < 0.001). Furthermore, in multivariable analyses, increased IMT was associated

with variant 5-LO genotype (OR: 4.1; 95% CI: 2.1–8.2;  $p < 0.001$ ), compared with wild-type genotypes.

Another study (114) assessed the association between a four-marker single-nucleotide polymorphism haplotype in the locus spanning the gene encoding FLAP (*ALOX5AP*) and the risk of MI and stroke in two independent populations. In 713 Icelandic individuals with MI and their unaffected relatives, as well as in a British cohort that included 753 individuals with MI and 730 control subjects, haplotype variants in the FLAP gene were associated with a 1.5- to 2-fold increased risk of MI and stroke. In addition, elevated release of LTB<sub>4</sub> was observed in males who carry the at-risk haplotype compared with population-based control subjects.

## LIPOPROTEIN LIPASE

Lipoprotein lipase (LPL), a member of the lipase gene family (115), is a hydrophilic enzyme that may play a central role in lipid metabolism. A 52-kDa glycoprotein, LPL comprises two domains, one smaller C-type domain (carboxy-terminal domain), which is critical for binding to the substrate, and a larger amino-terminal domain (N-terminal domain), responsible for the catalytic activity of the enzyme. The major sources of LPL synthesis are skeletal and heart muscle as well as adipose tissue, from which the mature enzyme is then secreted and transported to the vascular endothelium, the physiological site of the enzyme's action (116). LPL is bound to the luminal surface via highly charged heparan sulfate proteoglycans. To achieve its highest catalytic activity, LPL requires a specific cofactor, Apo C-II (117), which is found in chylomicrons, whereas Apo C-III seems to inhibit the action of the enzyme (118).

### *Actions of LPL*

The physiological action of LPL consists of the hydrolysis of the triacylglycerol component of triglycerides and VLDL, resulting in the production of chylomicron remnants, and in the case of VLDL, resulting in the production of smaller, intermediate-density lipoproteins (IDLs) (119). During a further hydrolysis of IDL by the enzyme, LDL is formed, providing cells with the cholesterol needed to build up cellular membranes. Thus, the efficient lipolysis of triglyceride-rich lipoproteins, with their removal from the circulation, and the generation of material for HDL formation are viewed as antiatherogenic effects of LPL.

LPL is also synthesized by macrophages and macrophage-derived foam cells in atherosclerotic lesions (so-called vessel wall LPL) (120,121), and this fraction of the enzyme has been linked to LPL-related proatherogenic effects. Indeed, local LPL activity on the vascular endothelium leads to a decrease in lipid size and to the production of smaller cholesterol-rich remnants and LDLs, facilitating their penetration of the endothelium. In addition, *in vitro* studies showed that this process (i.e., lipolysis) could increase the permeability of the endothelial barrier. In the intima, such smaller lipoproteins can be rapidly taken up by macrophages (122), thereby enhancing deposition of cholesterol esters within macrophages and their subsequent transformation into foam cells.

Apart from its lipolytic activity, LPL has been shown to possess a noncatalytic activity on lipoproteins such as molecular bridging (123). Bridging function of the enzyme consists of the ability of LPL to anchor lipid particles, since the enzyme can interact simultaneously with both lipoproteins and proteoglycans via separate domains. As a result, increased binding and retention of LDL-C by proteoglycans of the subendothelial matrix occurs, thereby proposing LPL activity in the arterial wall to promote atherosclerosis.



### ***Association of LPL With Cardiovascular Risk***

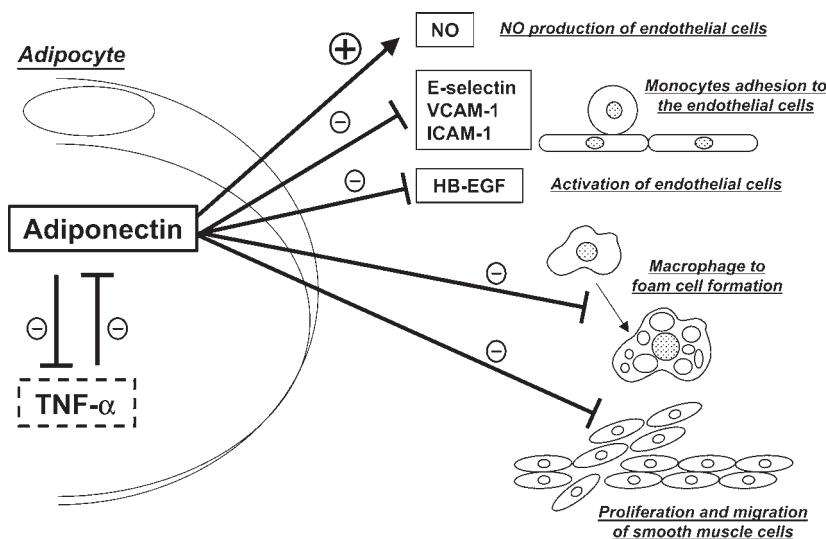
Epidemiological evidence on the potential role of LPL in CHD remains scarce and controversial. The association between LPL activity and mass and the presence of CAD were studied in a large cohort of patients with CAD participating in the Regression Growth Evaluation Statin Study (124). Patients with the lowest LPL activity reported more severe angina pectoris according to New York Heart Association classification, compared with patients in the highest quartile of the LPL distribution. The results of a small case–control study from Japan also showed considerably lower levels of preheparin serum LDL mass in patients with coronary atherosclerosis, compared with those in healthy men (125). Another case–control study (126) included 194 patients with and without angiographically proven CAD ( $n = 158$  and  $36$ , respectively) and demonstrated no differences in LPL activity or concentration between these groups. In addition, no association between LPL quartile distribution and severity and extension of CAD, as assessed by various coronary scores, was found. Thus, inconsistency in cross-sectional studies and absence of prospective studies does not call for LPL determination in plasma as a useful marker of cardiovascular risk.

### **ADIPONECTIN**

Adiponectin is a 244 amino acid collagen-like protein, a member of a family of obesity-related hormones, the adipocytokines, and is produced solely by white adipose tissue. Adiponectin is also referred to as gelatin-binding protein-28 (GBP-28), adipocyte complement-related protein (Acrp 30), or Adipo Q, although the latter two represent a mouse homolog of adiponectin. Structurally, it consists of a collagenous tail and a globular head, which form trimer-dimers and are found as a high molecular weight complex in the circulation in relatively high concentrations (2–30 mg/L) (127–129).

### ***Actions of Adiponectin***

The mechanisms whereby adiponectin exerts its physiological actions are not entirely clear. Apart from its role as an insulin-sensitizing agent, and its implication in metabolic disorders, adiponectin might also be involved in the regulation of inflammatory processes that contribute to atherosclerosis. Because adiponectin and TNF- $\alpha$  are both secreted by adipose tissue, a direct link between these two markers seems conceivable. Indeed, TNF- $\alpha$  has been suggested to be a strong inhibitor of the adiponectin promoter activity (130), whereas adiponectin, in turn, reduces the secretion of TNF- $\alpha$  from monocytes/macrophages (131) and is also able to reverse some of the deleterious effects induced by this cytokine on the endothelium. For instance, adiponectin inhibits the TNF- $\alpha$ -induced expression of ICAM-1, VCAM-1, and E-selectin (132) and prevents the attachment of monocytes to the endothelial surface (Fig. 4). Inhibition of nuclear factor- $\kappa$ B signaling by physiological concentrations of adiponectin through a cyclic adenosine monophosphate–dependent pathway is considered the underlying molecular mechanism responsible for this action (133). Through the inhibition of class A macrophage scavenger receptor (SR-A) gene expression, adiponectin reduces cholesterol ester accumulation and decreases oxLDL uptake, thereby diminishing the transformation of macrophages into foam cells (134). SMC proliferation and migration induced by heparin-binding epidermal growth factor (EGF)-like growth factor (HB-EGF), EGF, basic fibroblastic growth factor, and platelet-derived growth factor is also suppressed by adiponectin (135). Data on adiponectin-deficient mice have shown a twofold increase in neointimal thickening and increased proliferation of



**Fig. 4.** Protective action of adiponectin in the initiation and progression of atherosclerosis through anti-inflammatory and antiatherogenic effects. NO, nitric oxide. (Reprinted from ref. 128 with permission from Elsevier, Copyright 2005.)

VSMCs in arteries after mechanical injury (135,136). In addition, adiponectin knockout mice have shown high levels of TNF- $\alpha$  mRNA in adipose tissue (137).

### *Association of Adiponectin With Cardiovascular Risk*

The experimental studies discussed above suggest an antiatherogenic role of adiponectin and that hypoadiponectinemia therefore might be associated with increased risk of atherosclerotic disease. Indeed, several cross-sectional clinical studies have reported lower serum levels in patients with CHD (138–142) than in control subjects. Kumada et al. (138) studied 225 consecutive male patients with CHD and compared them with 225 voluntary blood donors. They found a twofold increased risk of CHD associated with low adiponectin levels (<4 mg/L) (multivariable-adjusted OR: 2.05; 95% CI: 1.29–4.95; Q1 vs referent Q4). In a study by Hotta et al. (139), diabetic patients with CAD also had lower adiponectin concentrations than those without macroangiopathy. In a large case–control study including 312 patients with angiographically defined stable CAD and 479 healthy blood donors, Rothenbacher et al. (140) observed a strong inverse association between serum levels of adiponectin and risk of CAD. Compared with subjects having adiponectin concentrations in the lower quintile, the OR for those in the upper quintile was 0.52 (95% CI: 0.28–0.95) after adjustment for covariates ( $p$  for trend of <0.007). After additional adjustment for HDL-C, the OR for CAD increased, reflecting the close association between adiponectin and HDL-C. The increase would have been less pronounced had the basic model been adjusted for markers of inflammation, or plasminogen activator inhibitor-1 and D-dimers. Hence, in this study the association between adiponectin concentrations and the presence of CAD showed a clear dose–response relationship that persisted after adjustment for conventional CAD risk factors including history of diabetes and body mass index.

Only one prospective study (143) has assessed the predictive value of adiponectin for future coronary events in apparently healthy subjects. Of 18,225 male participants in the Health Professionals' Follow-up Study, 266 men who subsequently developed coronary

events (fatal and nonfatal MI) during a 6-yr follow-up were compared with 532 event-free control subjects, matched for age, date of blood draw, and smoking status. A significantly reduced risk of subsequent acute MI associated with higher levels of adiponectin in serum at baseline was found; notably, this association was also reduced after adjustment for covariates but persisted after inclusion of lipids (LDL-C and HDL-C) in the model (RR: 0.56; 95% CI: 0.32–0.99; *p* for trend of 0.02). Further adjustment for glycemic status and CRP did not appreciably affect the results.

The protective effect of higher adiponectin concentrations for incident type 2 diabetes mellitus has previously been shown in diverse ethnic groups, i.e., in Pima Indians, representing a unique cohort with a high prevalence of obesity and diabetes (144); Caucasians in the European Prospective Investigation into Cancer and Nutrition study (145); Japanese men (146); Asian Indians (147); and, more recently, a biracial population of Caucasians and African Americans in the ARIC study (148). All prospective studies consistently demonstrated a significantly reduced risk of the incidence of diabetes mellitus associated with higher adiponectin concentrations.

More work is still needed to establish the role of this new biomarker in clinical medicine; however, the evidence available to date is promising with respect to adiponectin both as a novel biomarker of cardiovascular risks and as a potential therapeutic target.

## CONCLUSION

During the past decade, an increasing number of novel markers of cardiovascular risk have been identified. To be implemented in clinical practice, they should fulfill certain requirements (149), such as provided independent information on risk prediction in addition to global risk assessment, be reliable and easily reproducible, and show high sensitivity and specificity. Finally, simple and robust assays should be commercially available.

Among all biomarkers discussed in this chapter, only Lp-PLA<sub>2</sub>, which is directly involved in the oxidation of LDL and further atherosclerotic plaque development and has been investigated in several large prospective studies with consistent results, fulfills most of these requirements and might therefore be added to the clinical armamentarium for improved prediction of CVD. Others, such as oxLDL and adiponectin, remain the focus of intense research.

## REFERENCES

1. Stafforini DM, McIntyre TM, Zimmerman GA, et al. Platelet-activating factor acetylhydrolases. *J Biol Chem* 1997;272:17,895–17,898.
2. Arai H, Koizumi H, Aoki J, et al. Platelet-activating factor acetylhydrolase (PAF-AH). *J Biochem (Tokyo)* 2002;131:635–640.
3. Stafforini DM, Elstad MR, McIntyre TM, et al. Human macrophages secrete platelet-activating factor acetylhydrolase. *J Biol Chem* 1990;265:9682–9687.
4. Asano K, Okamoto S, Fukunaga K, et al. Cellular source(s) of platelet-activating-factor acetylhydrolase activity in plasma. *Biochem Biophys Res Commun* 1999;261:511–514.
5. Tarbet BE, Stafforini DM, Elstad MR, et al. Liver cells secrete the plasma form of platelet-activating factor acetylhydrolase. *J Biol Chem* 1991;266:16,667–16,673.
6. Hakkinen T, Luoma JS, Hiltunen MO, et al. Lipoprotein-associated phospholipase A<sub>2</sub>, platelet-activating factor acetylhydrolase, is expressed by macrophages in human and rabbit atherosclerotic lesions. *Arterioscl Thromb Vasc Biol* 1999;19:2909–2917.
7. Kolodgie FD, Burke AP, Taye A, et al. Lipoprotein-associated phospholipase A<sub>2</sub> is highly expressed in macrophages of coronary lesions prone to rupture. *Circulation* 2004;110(Suppl III):III-246. (Abstract).

8. Caslake MJ, Packard CJ, Suckling KE, et al. Lipoprotein-associated phospholipase A<sub>2</sub>, platelet-activating factor acetylhydrolase: a potential new risk factor for coronary artery disease. *Atherosclerosis* 2000;150:413–419.
9. Tsimihodimos V, Karabina SA, Tambaki AP, et al. Altered distribution of platelet-activating factor-acetylhydrolase activity between LDL and HDL as a function of the severity of hypercholesterolemia. *J Lipid Res* 2002;43:56–263.
10. Caslake MJ, Packard CJ. Lipoprotein-associated phospholipase A<sub>2</sub> (platelet-activating factor acetylhydrolase) and cardiovascular disease. *Curr Opin Lipidol* 2003;14:347–352.
11. Tjoelker LW, Wilder C, Eberhardt C, et al. Anti-inflammatory properties of a platelet-activating factor acetylhydrolase. *Nature* 1995;374:549–553.
12. Tjoelker LW, Stafforini DM. Platelet-activating factor acetylhydrolases in health and disease. *Biochim Biophys Acta* 2000;1488:102–123.
13. Quarck R, Des Geest B, Stengel D, et al. Adenovirus-mediated gene transfer of human platelet-activating factor-acetylhydrolase prevents injury-induced neointima formation and reduces spontaneous atherosclerosis in apolipoprotein E-deficient mice. *Circulation* 2001;103:2495–2500.
14. Tselepis AD, Chapman JM. Inflammation, bioactive lipids and atherosclerosis: potential roles of a lipoprotein-associated phospholipase A<sub>2</sub>, platelet activating factor-acetylhydrolase. *Atheroscler Suppl* 2002;3:57–68.
15. Dada N, Kim NW, Wolfert RL. Lp-PLA<sub>2</sub>: an emerging biomarker of coronary heart disease. *Expert Rev Mol Diagn* 2002;2:17–22.
16. Macphee CH, Moores KE, Boyd HF, et al. Lipoprotein-associated phospholipase A<sub>2</sub>, platelet-activating factor acetylhydrolase, generates two bioactive products during the oxidation of low-density lipoprotein: use of a novel inhibitor. *Biochem J* 1999;338:479–487.
17. Macphee CH. Lipoprotein-associated phospholipase A<sub>2</sub>: a potential new risk factor for coronary artery disease and a therapeutic target. *Curr Opin Pharmacol* 2001;121–125.
18. Leach CA, Hickey DM, Ife RJ, et al. Lipoprotein-associated PLA<sub>2</sub> inhibition—a novel, non-lipid lowering strategy for atherosclerosis therapy. *Farmacol* 2001;56:45–50.
19. Stafforini DM, Tjoelker LW, McCormick SP, et al. Molecular basis of the interaction between plasma platelet-activating factor acetylhydrolase and low density lipoprotein. *J Biol Chem* 1999;274:7018–7024.
20. Kume N, Cybulsky MI, Gimbrone MA Jr. Lysophosphatidylcholine, a component of atherogenic lipoproteins, induces mononuclear leukocyte adhesion molecules in cultured human and rabbit arterial endothelial cells. *J Clin Invest* 1992;90:1138–1144.
21. Quinn MT, Parthasarathy S, Steinberg D. Lysophosphatidylcholine: a chemotactic factor for human monocytes and its potential role in atherogenesis. *Proc Natl Acad Sci USA* 1988;85:2805–2809.
22. Carpenter KL, Dennis IF, Challis IR, et al. Inhibition of lipoprotein-associated phospholipase A<sub>2</sub> diminishes the death-inducing effects of oxidised LDL on human monocyte-macrophages. *FEBS Lett* 2001;505:357–363.
23. Blackie JA, Bloomer JC, Brown MJ, et al. The discovery of SB-435495: a potent, orally active inhibitor of lipoprotein-associated phospholipase A<sub>2</sub> for evaluation in man. *Bioorg Med Chem Lett* 2002;12:2603–2606.
24. Blackie JA, Bloomer JC, Brown MJ, et al. The identification of clinical candidate SB-480848: a potent inhibitor of lipoprotein-associated phospholipase A<sub>2</sub>. *Bioorg Med Chem Lett* 2003;13:1067–1070.
25. Johnson A, Zalewski A, Janmohamed S, et al. Lipoprotein-associated phospholipase A<sub>2</sub> activity, an emerging CV risk marker, can be inhibited in atherosclerotic lesions and plasma by novel pharmacologic intervention: the results of a multicenter clinical study. *Circulation* 2004;110(Suppl III):III–590. (Abstract).
26. Packard CJ, O'Reilly DS, Caslake MJ, et al. Lipoprotein-associated phospholipase A<sub>2</sub> as an independent predictor of coronary heart disease: West of Scotland Coronary Prevention Study Group. *N Engl J Med* 2000;343:1148–1155.
27. Blake GJ, Dada N, Fox JC, et al. A prospective evaluation of lipoprotein-associated phospholipase A<sub>2</sub> levels and the risk of future cardiovascular events in women. *J Am Coll Cardiol* 2001;38:1302–1306.
28. Satoh K, Imaizumi T, Yoshida H, et al. Platelet-activating factor acetylhydrolase in plasma lipoproteins of healthy men and women. *Clin Chim Acta* 1991;202:95–103.
29. Imaizumi T, Stafforini DM, Yamada Y, et al. The fate of platelet-activating factor: PAF acetylhydrolase from plasma and tissues. In: Gross R, ed. *Advances in Lipobiology (1)* JAI, Greenwich, CT, 1996; pp. 141–162.

30. Kosaka T, Yamaguchi M, Miyanaga K, et al. Serum platelet-activating factor acetylhydrolase (PAF-AH) activity in more than 3000 healthy Japanese. *Clin Chim Acta* 2001;312:179–183.
31. Miyaura S, Maki N, Byrd W, et al. The hormonal regulation of platelet-activating factor acetylhydrolase activity in plasma. *Lipids* 1991;26:1015–1020.
32. Satoh K, Imaizumi T, Yoshida H, et al. Effect of 17 beta-estradiol on secretion of platelet-activating factor acetylhydrolase by HepG2 cells. *Metabolism* 1993;42:672–677.
33. Yoshimura T, Ohshige A, Maeda T, et al. Estrogen replacement therapy decreases platelet-activating factor-acetylhydrolase activity in post-menopausal women. *Maturitas* 1999;31:249–253.
34. Ballantyne CM, Hoogeveen RC, Bang H, et al. Lipoprotein-associated phospholipase A<sub>2</sub>, high-sensitivity C-reactive protein, and risk for incident coronary heart disease in middle-aged men and women in the Atherosclerosis Risk in Communities (ARIC) study. *Circulation* 2004;109:837–842.
35. Koenig W, Khuseynova N, Lowel H, et al. Lipoprotein-associated phospholipase A<sub>2</sub> adds to risk prediction of incident coronary events by C-reactive protein in apparently healthy middle-aged men from the general population: results from the 14-year follow-up of a large cohort from southern Germany. *Circulation* 2004;110:1903–1908.
36. Brilakis ES, McConnell JP, Lennon RJ, et al. Higher levels of lipoprotein-associated phospholipase A<sub>2</sub> are associated with higher incidence of cardiovascular events at follow-up independent of C-reactive protein. *Eur Heart J* 2005;26:137–144.
37. Iribarren C, Gross MD, Darbinian JA, et al. Association of lipoprotein-associated phospholipase A<sub>2</sub> mass and activity with calcified coronary plaque in young adults: the CARDIA study. *Arterioscl Thromb Vasc Biol* 2005;25:216–221.
38. Oei HHS, Van der Meer IM, Hofman A, et al. Lipoprotein-associated phospholipase A<sub>2</sub> activity is associated with risk of coronary heart disease and ischemic stroke: the Rotterdam Study. *Eur Heart J* 2004;25(Abstract Suppl):234.
39. Ballantyne CM, Hoogeveen RC, Bang H, et al. The relation of lipoprotein-associated phospholipase A<sub>2</sub> (Lp-PLA<sub>2</sub>) and C-reactive protein to incident stroke in middle-aged men and women: the atherosclerosis risk in communities study. *Arterioscl Thromb Vasc Biol* 2004;24:e51–e136.
40. Shohet RV, Anwar A, Johnston JM, et al. Plasma platelet-activating factor acetylhydrolase activity is not associated with premature coronary atherosclerosis. *Am J Cardiol* 1999;83:109–111.
41. Blankenberg S, Stengel D, Rupprecht HJ, et al. Plasma PAF-acetylhydrolase in patients with coronary artery disease: results of a cross-sectional analysis. *J Lipid Res* 2003;44:1381–1386.
42. Winkler K, Abletshauser C, Friedrich I, et al. Fluvastatin slow-release lowers platelet-activating factor acetyl hydrolase activity: a placebo-controlled trial in patients with type 2 diabetes. *J Clin Endocrinol Metab* 2004;89:1153–1159.
43. Khuseynova N, Imhof A, Rothenbacher D, et al. Association between lipoprotein-associated phospholipase A<sub>2</sub> and coronary artery disease: focus on its relationship with lipoproteins and markers of inflammation and hemostasis. *Atherosclerosis* 2005;182:181–188.
44. Wolfert RL, Kim NW, Selby RG, et al. Biological variability and specificity of lipoprotein-associated phospholipase A<sub>2</sub>, a novel marker of cardiovascular risk. *Circulation* 2004;110(Suppl III):III-309. (Abstract).
45. Tsimihodimos V, Karabina SA, Tambaki AP, et al. Atorvastatin preferentially reduces LDL-associated platelet-activating factor acetylhydrolase activity in dyslipidemias of type IIA and type IIB. *Arterioscl Thromb Vasc Biol* 2002;22:306–311.
46. Albert MA, Glynn RJ, Wolfert RL, et al. The effect of statin therapy on lipoprotein-associated phospholipase A<sub>2</sub> levels. *Atherosclerosis* 2005;182:193–198.
47. Tsimihodimos V, Kakafika A, Tambaki AP, et al. Fenofibrate induces HDL-associated PAF-AH but attenuates enzyme activity associated with apoB-containing lipoproteins. *J Lipid Res* 2003;44:927–934.
48. Murakami M, Nakatani Y, Atsumi G, et al. Regulatory functions of phospholipase A<sub>2</sub>. *Crit Rev Immunol* 1997;17:225–283.
49. Niessen HW, Krijnen PA, Visser CA, et al. Type II secretory phospholipase A<sub>2</sub> in cardiovascular disease: a mediator in atherosclerosis and ischemic damage to cardiomyocytes? *Cardiovasc Res* 2003;60:68–77.
50. Jaross W, Eckey R, Menschikowski M. Biological effects of secretory phospholipase A<sub>2</sub> group IIA on lipoproteins and in atherogenesis. *Eur J Clin Invest* 2002;32:383–393.
51. Peilot H, Rosengren B, Bondjers G, et al. Interferon-gamma induces secretory group IIA phospholipase A<sub>2</sub> in human arterial smooth muscle cells: involvement of cell differentiation, STAT-3 activation, and modulation by other cytokines. *J Biol Chem* 2000;275:22,895–22,904.

52. Hurt-Camejo E, Camejo G, Peilot H, et al. Phospholipase A<sub>2</sub> in vascular disease. *Circ Res* 2001;89:298–304.
53. Anthonen MW, Stengel D, Hourton D, et al. Mildly oxidized LDL induces expression of group IIa secretory phospholipase A<sub>2</sub> in human monocyte-derived macrophages. *Arterioscl Thromb Vasc Biol* 2000;20:1276–1282.
54. Fourcade O, Le Balle F, Fauvel J, et al. Regulation of secretory type-II phospholipase A<sub>2</sub> and of lyso-phosphatidic acid synthesis. *Adv Enzyme Regul* 1998;38:99–107.
55. Schiering A, Menschikowski M, Mueller E, et al. Analysis of secretory group II phospholipase A<sub>2</sub> expression in human aortic tissue in dependence on the degree of atherosclerosis. *Atherosclerosis* 1999;144:73–78.
56. Laine VJ, Grass DS, Nevalainen TJ. Protection by group II phospholipase A<sub>2</sub> against *Staphylococcus aureus*. *J Immunol* 1999;162:7402–7408.
57. Weinrauch Y, Abad C, Liang NS, et al. Mobilization of potent plasma bactericidal activity during systemic bacterial challenge: role of group II phospholipase A<sub>2</sub>. *J Clin Invest* 1998;102:633–638.
58. Sartipy P, Bondjers G, Hurt-Camejo E. Phospholipase A<sub>2</sub> type II binds to extracellular matrix biglycan: modulation of its activity on LDL by colocalization in glycosaminoglycan matrixes. *Arterioscl Thromb Vasc Biol* 1998;18:1934–1941.
59. Sartipy P, Camejo G, Svensson L, et al. Phospholipase A<sub>2</sub> modification of low density lipoproteins forms small high density particles with increased affinity for proteoglycans and glycosaminoglycans. *J Biol Chem* 1999;274:25,913–25,920.
60. Pratico D. F(2)-isoprostanes: sensitive and specific non-invasive indices of lipid peroxidation in vivo. *Atherosclerosis* 1999;147:1–10.
61. Leitinger N, Watson AD, Hama SY, et al. Role of group II secretory phospholipase A<sub>2</sub> in atherosclerosis: 2. Potential involvement of biologically active oxidized phospholipids. *Arterioscl Thromb Vasc Biol* 1999;19:1291–1298.
62. Ivandic B, Castellani LW, Wang XP, et al. Role of group II secretory phospholipase A<sub>2</sub> in atherosclerosis: 1. Increased atherogenesis and altered lipoproteins in transgenic mice expressing group IIa phospholipase A<sub>2</sub>. *Arterioscl Thromb Vasc Biol* 1999;19:1284–1290.
63. Kugiyama K, Ota Y, Takazoe K, et al. Circulating levels of secretory type II phospholipase A<sub>2</sub> predict coronary events in patients with coronary artery disease. *Circulation* 1999;100:1280–1284.
64. Liu PY, Li YH, Tsai WC, et al. Prognostic value and the changes of plasma levels of secretory type II phospholipase A<sub>2</sub> in patients with coronary artery disease undergoing percutaneous coronary intervention. *Eur Heart J* 2003;24:1824–1832.
65. Kugiyama K, Ota Y, Sugiyama S, et al. Prognostic value of plasma levels of secretory type II phospholipase A<sub>2</sub> in patients with unstable angina pectoris. *Am J Cardiol* 2000;86:718–722.
66. Fichtlscherer S, Kaszkin M, Breuer S, et al. Elevated secretory non-pancreatic type II phospholipase A<sub>2</sub> serum activity is associated with impaired endothelial vasodilator function in patients with coronary artery disease. *Clin Sci (Lond)* 2004;106:511–517.
67. Witztum JL, Steinberg D. The oxidative modification hypothesis of atherosclerosis: does it hold for humans? *Trends Cardiovasc Med* 2001;11:93–102.
68. Steinberg D. Low density lipoprotein oxidation and its pathobiological significance. *J Biol Chem* 1997;272:20,963–20,966.
69. Cushing SD, Berliner JA, Valente AJ, et al. Minimally modified low density lipoprotein induces monocyte chemotactic protein 1 in human endothelial cells and smooth muscle cells. *Proc Natl Acad Sci USA* 1990;87:5134–5138.
70. Rajavashisth TB, Andalibi A, Territo MC, et al. Induction of endothelial cell expression of granulocyte and macrophage colony-stimulating factors by modified low-density lipoproteins. *Nature* 1990;344:254–257.
71. Jessup W, Kritharides L, Stocker R. Lipid oxidation in atherogenesis: an overview. *Biochem Soc Trans* 2004;32:134–138.
72. Holvoet P, Vanhaecke J, Janssens S, et al. Oxidized LDL and malondialdehyde-modified LDL in patients with acute coronary syndromes and stable coronary artery disease. *Circulation* 1998;98:1487–1494.
73. Toshima S, Hasegawa A, Kurabayashi M, et al. (2000) Circulating oxidized low density lipoprotein levels: a biochemical risk marker for coronary heart disease. *Arterioscl Thromb Vasc Biol* 2000;20:2243–2247.
74. Ehara S, Ueda M, Naruko T, et al. Elevated levels of oxidized low density lipoprotein show a positive relationship with the severity of acute coronary syndromes. *Circulation* 2001;103:1955–1960.

75. Holvoet P, Mertens A, Verhamme P, et al. Circulating oxidized LDL is a useful marker for identifying patients with coronary artery disease. *Arterioscl Thromb Vasc Biol* 2001;21:844–848.
76. Holvoet P, Stassen JM, Van Cleemput J, et al. Oxidized low density lipoproteins in patients with transplant-associated coronary artery disease. *Arterioscl Thromb Vasc Biol* 1998;18:100–107.
77. Liu ML, Ylitalo K, Salonen R, et al. Circulating oxidized low-density lipoprotein and its association with carotid intima-media thickness in asymptomatic members of familial combined hyperlipidemia families. *Arterioscl Thromb Vasc Biol* 2004;24:1492–1497.
78. Hulthe J, Fagerberg B. Circulating oxidized LDL is associated with subclinical atherosclerosis development and inflammatory cytokines (AIR Study). *Arterioscl Thromb Vasc Biol* 2002;22:1162–1167.
79. Salonen JT, Yla-Herttuala S, Yamamoto R, et al. Autoantibody against oxidised LDL and progression of carotid atherosclerosis. *Lancet* 1992;339:883–887.
80. Fredrikson NG, Hedblad B, Berglund G, et al. Plasma oxidized LDL: a predictor for acute myocardial infarction? *J Intern Med* 2003;253:425–429.
81. Meisinger C, Baumert J, Khuseynova N, et al. Plasma oxidized low density lipoprotein: a strong predictor for acute coronary heart disease events in apparently healthy middle aged men from the general population. *Circulation* 2005;112:651–657.
82. Violi F, Micheletta F, Iuliano L. Vitamin E, atherosclerosis and thrombosis. *Thromb Haemost* 2001;85:766–770.
83. Alpha-Tocopherol, Beta-Carotene Cancer Prevention Study Group. The effect of vitamin E and beta-carotene on the incidence of lung cancer and other cancers in male smokers. *N Engl J Med* 1994;330:1029–1035.
84. De Gaetano G; Collaborative Group of the Primary Prevention Project. Low-dose aspirin and vitamin E in people at cardiovascular risk: a randomised trial in general practice: Collaborative Group of the Primary Prevention Project. *Lancet* 2001;357:89–95.
85. Stephens NG, Parsons A, Schofield PM, et al. Randomised controlled trial of vitamin E in patients with coronary disease: Cambridge Heart Antioxidant Study (CHAOS). *Lancet* 1996;347:781–785.
86. GISSI-Prevenzione Investigators (Gruppo Italiano per lo Studio della Sopravvivenza nell'Infarto miocardico). Dietary supplementation with n-3 polyunsaturated fatty acids and vitamin E after myocardial infarction: results of the GISSI-Prevenzione trial. Gruppo Italiano per lo Studio della Sopravvivenza nell'Infarto miocardico. *Lancet* 1999;354:447–455.
87. Yusuf S, Dagenais G, Pogue J, et al. Vitamin E supplementation and cardiovascular events in high-risk patients. The Heart Outcomes Prevention Evaluation Study Investigators. *N Engl J Med* 2000;342:154–160.
88. Vivekananthan DP, Penn MS, Sapp SK, et al. Use of antioxidant vitamins for the prevention of cardiovascular disease: metaanalysis of randomised trials. *Lancet* 2003;361:2017–2023.
89. Boaz M, Smetana S, Weinstein T, et al. Secondary prevention with antioxidants of cardiovascular disease in endstage renal disease (SPACE): randomised placebo-controlled trial. *Lancet* 2000;356:1213–1218.
90. Blankenberg S, Rupprecht HJ, Bickel C, et al. Glutathione peroxidase 1 activity and cardiovascular events in patients with coronary artery disease. *N Engl J Med* 2003;349:1605–1613.
91. Zhao L, Funk CD. Lipoxygenase pathways in atherogenesis. *Trends Cardiovasc Med* 2004;14:191–195.
92. Funk CD, Cyrus T. 12/15-lipoxygenase, oxidative modification of LDL and atherogenesis. *Trends Cardiovasc Med* 2001;11:116–124.
93. Yla-Herttuala S, Rosenfeld ME, Parthasarathy S, et al. Colocalization of 15-lipoxygenase mRNA and protein with epitopes of oxidized low density lipoprotein in macrophage-rich areas of atherosclerotic lesions. *Proc Natl Acad Sci USA* 1990;87:6959–6963.
94. Huo Y, Zhao L, Hyman MC, et al. Critical role of macrophage 12/15-lipoxygenase for atherosclerosis in apolipoprotein E-deficient mice. *Circulation* 2004;110:2024–2031.
95. George J, Afek A, Shaish A, et al. 12/15-Lipoxygenase gene disruption attenuates atherogenesis in LDL receptor-deficient mice. *Circulation* 2001;104:1646–1650.
96. Cyrus T, Pratico D, Zhao L, et al. Absence of 12/15-lipoxygenase expression decreases lipid peroxidation and atherogenesis in apolipoprotein e-deficient mice. *Circulation* 2001;103:2277–2282.
97. Cyrus T, Witztum JL, Rader DJ, et al. Disruption of the 12/15-lipoxygenase gene diminishes atherosclerosis in apo E-deficient mice. *J Clin Invest* 1999;103:1597–1604.
98. Harats D, Shaish A, George J, et al. Overexpression of 15-lipoxygenase in vascular endothelium accelerates early atherosclerosis in LDL receptor-deficient mice. *Arterioscl Thromb Vasc Biol* 2000;20:2100–2105.
99. Reilly KB, Srinivasan S, Hatley ME, et al. 12/15-Lipoxygenase activity mediates inflammatory monocyte/endothelial interactions and atherosclerosis in vivo. *J Biol Chem* 2004;279:9440–9450.

100. Shen J, Herderick E, Cornhill JF, et al. Macrophage-mediated 15-lipoxygenase expression protects against atherosclerosis development. *J Clin Invest* 1996;98:2201–2208.
101. Bocan TM, Rosebury WS, Mueller SB, et al. A specific 15-lipoxygenase inhibitor limits the progression and monocyte-macrophage enrichment of hypercholesterolemia-induced atherosclerosis in the rabbit. *Atherosclerosis* 1998;136:203–216.
102. Sendobry SM, Cornicelli JA, Welch K, et al. Attenuation of diet-induced atherosclerosis in rabbits with a highly selective 15-lipoxygenase inhibitor lacking significant antioxidant properties. *Br J Pharmacol* 1997;120:1199–1206.
103. Mehrabian M, Allayee H. 5-Lipoxygenase and atherosclerosis. *Curr Opin Lipidol* 2003;14:447–457.
104. Dixon RA, Diehl RE, Opas E, et al. Requirement of a 5-lipoxygenase-activating protein for leukotriene synthesis. *Nature* 1990;343:282–284.
105. Reid GK, Kargman S, Vickers PJ, et al. Correlation between expression of 5-lipoxygenase-activating protein, 5-lipoxygenase, and cellular leukotriene synthesis. *J Biol Chem* 1990;265:19,818–19,823.
106. Abramovitz M, Wong E, Cox ME, et al. 5-Lipoxygenase-activating protein stimulates the utilization of arachidonic acid by 5-lipoxygenase. *Eur J Biochem* 1993;215:105–111.
107. Funk CD. Prostaglandins and leukotrienes: advances in eicosanoid biology. *Science* 2001;294:1871–1975.
108. Coffey M, Peters-Golden M. Extending the understanding of leukotrienes in asthma. *Curr Opin Allergy Clin Immunol* 2003;3:57–63.
109. Hoover RL, Karnovsky MJ, Austen KF, et al. Leukotriene B<sub>4</sub> action on endothelium mediates augmented neutrophil/endothelial adhesion. *Proc Natl Acad Sci USA* 1984;81:2191–2193.
110. Lee S, Felts KA, Parry GC, et al. Inhibition of 5-lipoxygenase blocks IL-1 beta-induced vascular adhesion molecule-1 gene expression in human endothelial cells. *J Immunol* 1997;158:3401–3407.
111. Vila L. Cyclooxygenase and 5-lipoxygenase pathways in the vessel wall: role in atherosclerosis. *Med Res Rev* 2004;24:399–424.
112. Spanbroek R, Grabner R, Lotzer K, et al. Expanding expression of the 5-lipoxygenase pathway within the arterial wall during human atherogenesis. *Proc Natl Acad Sci USA* 2003;100:1238–1243.
113. Dwyer JH, Allayee H, Dwyer KM, et al. Arachidonate 5-lipoxygenase promoter genotype, dietary arachidonic acid, and atherosclerosis. *N Engl J Med* 2004;350:29–37.
114. Helgadottir A, Manolescu A, Thorleifsson G, et al. The gene encoding 5-lipoxygenase activating protein confers risk of myocardial infarction and stroke. *Nat Genet* 2004;36:233–239.
115. Hide WA, Chan L, Li WH. Structure and evolution of the lipase superfamily. *J Lipid Res* 1992;33:167–178.
116. Mead JR, Irvine SA, Ramji DP. Lipoprotein lipase: structure, function, regulation, and role in disease. *J Mol Med* 2002;80:753–769.
117. Braun JE, Severson DL. Regulation of the synthesis, processing and translocation of lipoprotein lipase. *Biochem J* 1992;287:337–347.
118. Otarod JK, Goldberg IJ. Lipoprotein lipase and its role in regulation of plasma lipoproteins and cardiac risk. *Curr Atheroscl Rep* 2004;6:335–342.
119. Goldberg IJ. Lipoprotein lipase and lipolysis: central roles in lipoprotein metabolism and atherogenesis. *J Lipid Res* 1996;37:693–707.
120. Yla-Herttuala S, Lipton BA, Rosenfeld ME, et al. Macrophages and smooth muscle cells express lipoprotein lipase in human and rabbit atherosclerotic lesions. *Proc Natl Acad Sci USA* 1991;88:10,143–10,147.
121. O'Brien KD, Gordon D, Deeb S, et al. Lipoprotein lipase is synthesized by macrophage-derived foam cells in human coronary atherosclerotic plaques. *J Clin Invest* 1992;89:1544–1550.
122. Lindqvist P, Ostlund-Lindqvist AM, Witztum JL, et al. The role of lipoprotein lipase in the metabolism of triglyceride-rich lipoproteins by macrophages. *J Biol Chem* 1983;258:9086–9092.
123. Mead JR, Ramji DP. The pivotal role of lipoprotein lipase in atherosclerosis. *Cardiovasc Res* 2002;55:261–269.
124. Kastelein JJ, Jukema JW, Zwinderman AH, et al. Lipoprotein lipase activity is associated with severity of angina pectoris. REGRESS Study Group. *Circulation* 2000;102:1629–1633.
125. Hitsumoto T, Ohsawa H, Uchi T, et al. Preheparin serum lipoprotein lipase mass is negatively related to coronary atherosclerosis. *Atherosclerosis* 2000;153:391–396.
126. Dugi KA, Schmidt N, Brandauer K, et al. Activity and concentration of lipoprotein lipase in post-heparin plasma and the extent of coronary artery disease. *Atherosclerosis* 2002;163:127–134.
127. Chandran M, Phillips SA, Ciaraldi T, et al. Adiponectin: more than just another fat cell hormone? *Diabetes Care* 2003;26:2442–2450.



128. Shimada K, Miyazaki T, Daida H. Adiponectin and atherosclerotic disease. *Clin Chim Acta* 2004;344:1–12.
129. Goldstein BJ, Scalia R. Adiponectin: a novel adipokine linking adipocytes and vascular function. *J Clin Endocrinol Metab* 2004;89:2563–2568.
130. Kappes A, Loffler G. Influences of ionomycin, dibutyl-cycloAMP and tumour necrosis factor-alpha on intracellular amount and secretion of apM1 in differentiating primary human preadipocytes. *Horm Metab Res* 2000;32:548–554.
131. Yokota T, Oritani K, Takahashi I, et al. Adiponectin, a new member of the family of soluble defense collagens, negatively regulates the growth of myelomonocytic progenitors and the functions of macrophages. *Blood* 2000;96:1723–1732.
132. Ouchi N, Kihara S, Arita Y, et al. Novel modulator for endothelial adhesion molecules: adipocyte-derived plasma protein adiponectin. *Circulation* 1999;100:2473–2476.
133. Ouchi N, Kihara S, Arita Y, et al. Adiponectin, an adipocyte-derived plasma protein, inhibits endothelial NF- $\kappa$ B signaling through a cAMP-dependent pathway. *Circulation* 2000;102:1296–1301.
134. Ouchi N, Kihara S, Arita Y, et al. Adipocyte-derived plasma protein, adiponectin, suppresses lipid accumulation and class A scavenger receptor expression in human monocyte-derived macrophages. *Circulation* 2001;103:1057–1063.
135. Matsuda M, Shimomura I, Sata M, et al. Role of adiponectin in preventing vascular stenosis: the missing link of adipo-vascular axis. *J Biol Chem* 2002;277:37,487–37,491.
136. Kubota N, Terauchi Y, Yamauchi T, et al. Disruption of adiponectin causes insulin resistance and neointimal formation. *J Biol Chem* 2002;277:25,863–25,866.
137. Maeda N, Shimomura I, Kishida K, et al. Diet-induced insulin resistance in mice lacking adiponectin/ACRP30. *Nat Med* 2002;8:731–737.
138. Kumada M, Kihara S, Sumitsuji S, et al. Association of hypoadiponectinemia with coronary artery disease in men. *Arterioscl Thromb Vasc Biol* 2003;23:85–89.
139. Hotta K, Funahashi T, Arita Y, et al. Plasma concentrations of a novel, adipose-specific protein, adiponectin, in type 2 diabetic patients. *Arterioscl Thromb Vasc Biol* 2000;20:1595–1599.
140. Rothenbacher D, Brenner H, Marz W, Koenig W. Adiponectin, risk of coronary heart disease and correlations with cardiovascular risk markers. *Eur Heart J* 2005;26:1640–1646.
141. Nakamura Y, Shimada K, Fukuda D, et al. Implications of plasma concentrations of adiponectin in patients with coronary artery disease. *Heart* 2004;90:528–533.
142. Kojima S, Funahashi T, Sakamoto T, et al. The variation of plasma concentrations of a novel, adipocyte derived protein, adiponectin, in patients with acute myocardial infarction. *Heart* 2003;89:667.
143. Pischon T, Girman CJ, Hotamisligil GS, et al. Plasma adiponectin levels and risk of myocardial infarction in men. *JAMA* 2004;291:1730–1737.
144. Lindsay RS, Funahashi T, Hanson RL, et al. Adiponectin and development of type 2 diabetes in the Pima Indian population. *Lancet* 2002;360:57, 58.
145. Spranger J, Kroke A, Mohlig M, et al. Adiponectin and protection against type 2 diabetes mellitus. *Lancet* 2003;361:226–228.
146. Daimon M, Oizumi T, Saitoh T, et al. Decreased serum levels of adiponectin are a risk factor for the progression to type 2 diabetes in the Japanese Population: the Funagata study. *Diabetes Care* 2003;26:2015–2020.
147. Snehaltha C, Mukesh B, Simon M, et al. Plasma adiponectin is an independent predictor of type 2 diabetes in Asian Indians. *Diabetes Care* 2003;26:3226–3229.
148. Duncan BB, Schmidt MI, Pankow JS, et al. Adiponectin and the development of type 2 diabetes: the atherosclerosis risk in communities study. *Diabetes* 2004;53:2473–2478.
149. Manolio T. Novel risk markers and clinical practice. *N Engl J Med* 2003;349:1587–1589.

---

# VII

## CONTEMPORARY AND FUTURE APPLICATIONS OF BIOMARKERS IN CLINICAL CARE

---



# 31

---

## A Multimarker Approach to Evaluation of Patients With Acute Coronary Syndrome

---

*David A. Morrow, MD, MPH*

### CONTENTS

INTRODUCTION
CHARACTERIZING PATHOGENESIS AND PROGNOSIS IN ACS
SIMPLE MULTIMARKER APPROACHES
MULTIMARKER APPROACHES USING THREE OR MORE MARKERS
FACING THE COMPLEXITY OF A MULTIMARKER STRATEGY
CONCLUSION
REFERENCES

---

### SUMMARY

The clinical application of biomarkers in patients with acute ischemic heart disease has evolved substantially. No longer is their use limited to the diagnosis of myocardial necrosis. Cardiac biomarkers may now be used as convenient and noninvasive tools to gain insight into the underlying causes and consequences of acute coronary syndrome (ACS) that mediate the risk of recurrent events and may be targets for therapeutic interventions. The emergence of novel biomarkers of inflammation, thrombosis, and hemodynamic stress have made possible an expanded role of multiple biomarkers, some old, others new, in the classification of patients with ACS. As proof of principle, a simple multimarker strategy using cardiac troponin, B-type natriuretic peptide, and C-reactive protein has been shown to enhance risk assessment. More work is needed to define the appropriate therapeutic responses to elevation of these novel markers. Moreover, as the understanding of the pathogenesis of ACS advances and new markers and therapies are discovered, the potential of multimarker strategies to add to present tools for clinical decision making and risk stratification will continue to evolve. This chapter describes the genesis and initial evaluation of the multimarker paradigm.

### INTRODUCTION

The clinical application of biomarkers in cardiovascular disease has evolved substantially since the first report of protein biomarkers of myocyte necrosis in the 1950s (1). From that time until the late 1990s, the clinical (and to a large extent investigational)

From: *Contemporary Cardiology:  
Cardiovascular Biomarkers: Pathophysiology and Disease Management*  
Edited by: David A. Morrow © Humana Press Inc., Totowa, NJ

focus remained on improving biomarkers of myocardial necrosis. However, concurrent major advances in the understanding of the pathogenesis and consequences of acute coronary atherothrombosis provided a strong stimulus for the development of new biomarkers aimed at detecting underlying contributors to acute plaque rupture and thrombosis, such as inflammation, platelet activation, and dysregulation of the coagulation cascade. The emergence of this new breed of pathobiologically diverse biomarkers, along with the desire to use these markers to provide insight into the dominant disease processes for the individual patient, created interest in an expanded role of multiple biomarkers, some old, others new, in the classification and selection of treatment for acute coronary syndromes (ACS) (2).

### CHARACTERIZING PATHOGENESIS AND PROGNOSIS IN ACS

ACS is a complex and heterogeneous syndrome with multiple potential etiologies, analogous to anemia or hypertension (3). It follows that therapy is likely to be most effective when directed at the underlying primary contributor. Braunwald (4) described five principle causes of ACS:

1. Plaque rupture with acute thrombosis.
2. Progressive mechanical obstruction.
3. Inflammation.
4. Secondary unstable angina.
5. Dynamic obstruction (coronary vasoconstriction) (4).

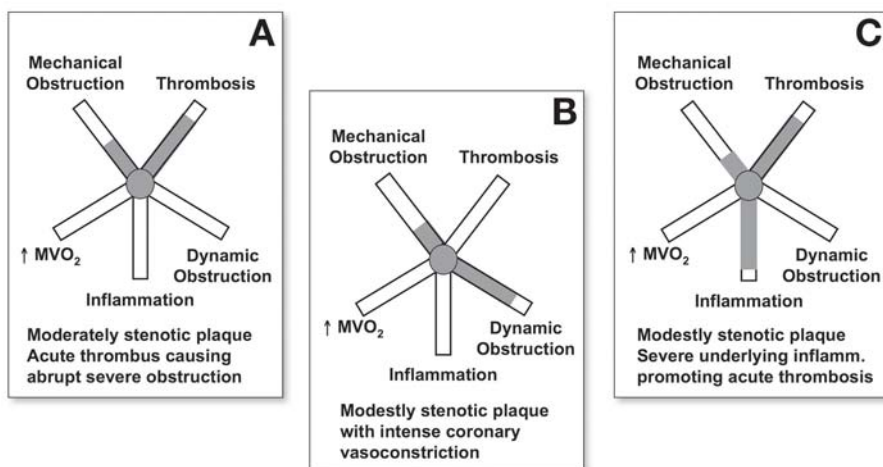
It is rare that any one of these processes exists in isolation, and inflammation appears to be a common thread in the majority of patients with atherothrombosis. Thus, patients with ACS may vary substantially with respect to the predominance of contributions from each of these major mechanisms and, as such, are likely to benefit from different treatment strategies (Fig. 1) (4). Moreover, the risk of subsequent death and/or recurrent ischemic events also varies widely among patients with ACS, depending on the presence and extent of irreversible myocyte injury, the hemodynamic consequences of ischemic injury, as well as the severity and tempo of atherosclerotic vascular disease.

#### *Potential Role of Biomarkers*

The emergence of novel biomarkers of inflammation, platelet activation, plaque instability, and hemodynamic stress, along with more sensitive biomarkers of necrosis, has made possible the potential to (a) noninvasively characterize the participation of these different contributors in any individual patient, (b) detect patients at higher risk of complications despite normal concentrations of traditional markers of necrosis, and (c) improve targeting of therapy to the underlying pathobiology (2). Contemporary investigation of biomarkers has put a strong emphasis on elucidating the pathobiological correlates of newer and established biomarkers. This avenue, in particular, has supported the concept that novel biomarkers may be used to direct therapy. For example, elevated levels of cardiac troponin in the blood of patients with non-ST-elevation ACS (NSTEMI) are associated with the presence of intracoronary thrombus, distal embolization of platelet microaggregates, and impaired microvascular flow in the myocardium (5,6). These observations have moved forward hand in hand with the demonstration of greater benefits of potent anti-thrombotic agents in patients with increased levels of troponin and proven this biomarker extremely useful for therapeutic decision making (*see* Chapter 5) (7,8). This paradigm

### Mechanisms of Acute Coronary Ischemia

- Progressive mechanical obstruction
- Acute thrombosis on pre-existing plaque
- Dynamic obstruction (coronary spasm or vasoconstriction)
- Inflammation and/or infection
- Secondary unstable angina

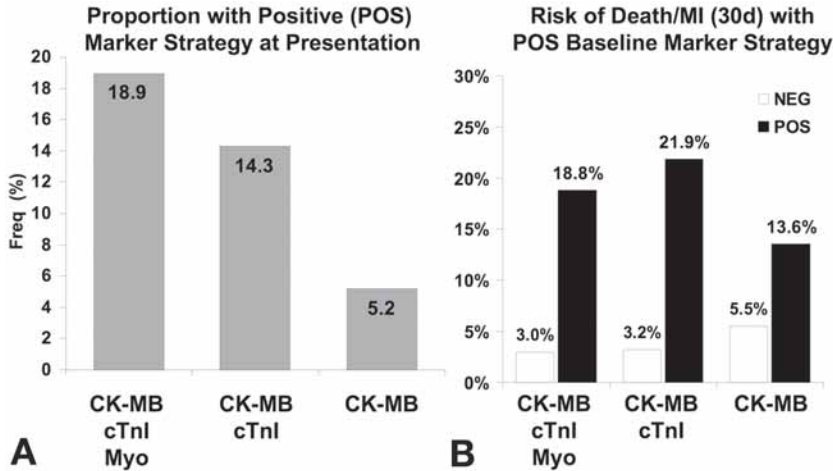


**Fig. 1.** Principal mechanisms of acute coronary ischemia. MVO<sub>2</sub>, myocardial oxygen demand; inflamm, inflammation. (Adapted from ref. 4.)

exemplified by cardiac troponin has provided a blueprint for the clinical evaluation of newer biomarkers of cardiovascular risk.

### Importance of Novel Biomarkers

The development and assessment of newer markers of inflammation, ischemia, thrombosis, and hemodynamic stress have been described in detail in other chapters of this volume. Notably, biomarkers of inflammation and hemodynamic stress have emerged as robust, independent predictors of outcome in patients with chronic and acute atherothrombosis (*see* Chapters 16, 17, 24). Specifically, high-sensitivity testing for C-reactive protein (high-sensitivity CRP [hsCRP]) is a convenient tool for detecting low-level systemic inflammation that portends a higher risk of developing atherothrombotic vascular disease (9), as well as poor short- and long-term prognosis in patients post-ACS (10,11). In addition, growing evidence implicates CRP as a mediator, in addition to a marker, of atherothrombosis (12). Similarly, the natriuretic peptides have been shown to provide important insight with respect to complications and outcomes among patients with ischemic heart disease. The concentration of B-type natriuretic peptide (BNP) and the N-terminal fragment of proBNP (NT-proBNP) correlates with left ventricular (LV) dilatation, remodeling, and dysfunction, as well as the risk of congestive heart failure (CHF) and death in patients presenting with acute myocardial infarction (AMI) (13,14). Moreover, at least 12 studies have demonstrated a robust association between BNP or NT-proBNP and the short and long-term risk of death across the spectrum of patients with ACS (15–19), including those without myocardial necrosis or clinical evidence of heart failure (18). More importantly, CRP and BNP/NT-proBNP, as well as other novel markers of inflammation and thrombosis, such as soluble CD40 ligand (CD40L) and myeloperoxidase (MPO)



**Fig. 2.** Proportion of patients with positive marker strategy at time of presentation (**A**) and risk of death or MI at 30 d (**B**) stratified by marker status in Chest Pain Evaluation by Creatine Kinase-MB, Myoglobin, and Troponin I study. Myo, myoglobin; Freq, frequency. (Data are from ref. 20.)

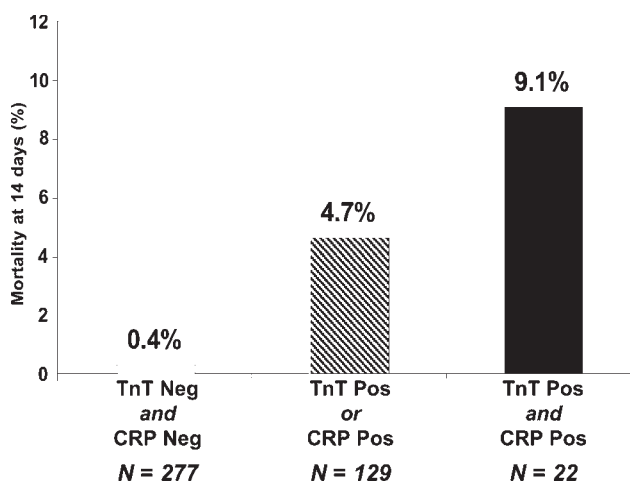
(see Chapter 18), are associated with outcome independently of the results of testing for cardiac troponin and, thus, set the stage for a combined assessment in multimarker strategies.

## SIMPLE MULTIMARKER APPROACHES

### *Combining Markers of Necrosis*

No available biomarker of necrosis offers the ideal properties of a very rapid early rise in conjunction with very high sensitivity and specificity (see Chapter 1). Thus, investigators have proposed the combined assessment of a marker with very rapid kinetics, such as myoglobin, along with a more specific marker of necrosis, such as troponin, to facilitate the diagnosis of MI. For example, in a study of 1005 patients with possible myocardial ischemia admitted to chest pain units, simultaneous quantitative testing for myoglobin, creatine kinase-MB (CK-MB), and cardiac troponin I (cTnI) reduced the time to detection of marker elevation (2.5 h) compared to either a strategy using only CK-MB and troponin (2.8 h) or local laboratory-based testing of CK-MB (3.4 h) (20). In addition, this multimarker strategy using markers of necrosis was positive in a larger proportion of patients (19 vs 5%) at presentation (Fig. 2A) and showed a more robust discrimination of the risk of death or MI than the single-marker approach (Fig. 2B). In this data set, there was no clear prognostic advantage of a strategy that included myoglobin compared with one based on CK-MB and troponin. By contrast, when studied among a population with a high clinical probability of ACS, interestingly, an elevated level of myoglobin was independently associated with mortality, even after controlling for CK-MB and troponin (21).

Strategies employing multiple markers of myocardial necrosis may also enable accelerated exclusion of MI. Application of bedside testing of myoglobin and cTnI among 817 patients being evaluated for possible AMI in the emergency department provided a sensitivity and a negative predictive value of 96.9 and 99.6%, respectively, by 90 min after presentation (22). Such data reinforce the potential for simultaneous testing of multiple markers to increase substantially the sensitivity of diagnostic and prognostic assessment of patients with possible ACS. Specific algorithms for clinical application are presented in Chapter 4.



**Fig. 3.** Risk of death through 14 d stratified by baseline testing for cTnT using a rapid qualitative assay and hsCRP (positive defined as  $\geq 15.5$  mg/ $\mu$ L) in patients with non-ST elevation ACS enrolled in TIMI 11A trial.

### *Enhanced Risk Assessment With Dual Marker Strategies in Combination With Troponin*

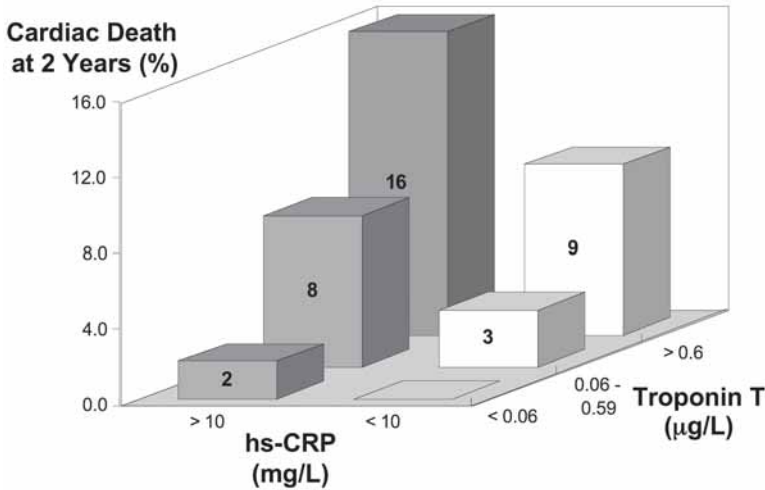
#### CRP AND TROPONIN

CRP has been an independent predictor of short- and/or long-term outcome among patients with NSTEMI in at least nine studies that have included multivariable analysis (11,23–31). Specifically, measurement of hsCRP appears to yield additional prognostic value in patients with negative testing of cardiac troponins (10,11) and adds to information obtained from the clinical history and electrocardiogram. With this background, my colleagues and I evaluated a strategy that combined testing for hsCRP and cardiac troponin T (cTnT) in patients with NSTEMI (10). We found that the dual marker strategy provided more comprehensive risk assessment. Stratified by both CRP and a qualitative assay for cTnT, patients with both an early positive cTnT and an elevated CRP were at highest risk of death by 14 d, followed by those who had either an elevated CRP or a positive cTnT. Patients with negative results for both assays were at very low risk of mortality (Fig. 3). These results were subsequently confirmed and extended with respect to cardiac mortality through 2 yr of follow-up in 917 patients with non-STEMI, among whom CRP was associated with a higher 2-yr risk of death regardless of troponin strata (Fig. 4) (11).

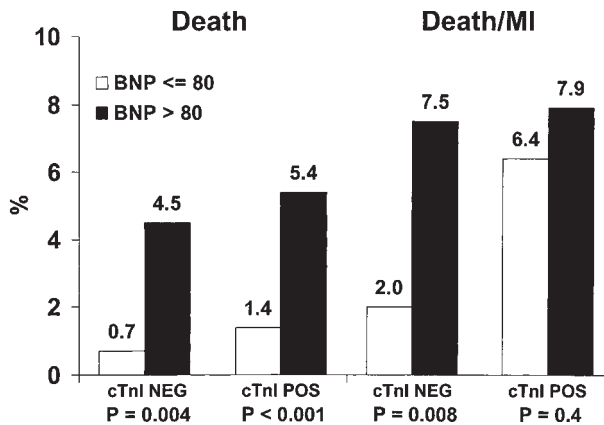
#### BNP/NT-PROBNP AND TROPONIN

BNP and NT-proBNP are strongly associated with prognosis in patients with ACS (14–19,32–36). The concentrations of BNP and NT-proBNP are elevated in 10–30% of patients with unstable angina (i.e., without myonecrosis) (15,18,37) and are also associated with survival in this group (see Chapter 24). When assessed in 1676 patients with NSTEMI, BNP offered significant prognostic information independently of cTnI, identifying patients at greater than fourfold higher risk of mortality among those with either negative (odds ratio [OR]: 6.9; 95% confidence interval [CI]: 1.9–25.8) or positive (OR: 4.1; 95% CI: 1.9–9.0) baseline troponin results (Fig. 5, left). Thus, the combined use of BNP and cTnI enhanced risk assessment, enabling discrimination of patients with negative BNP or troponin who were at increased risk of death or MI (Fig. 5, right). Among patients with a





**Fig. 4.** Risk of cardiac death at 2 yr stratified by cTnT and high-sensitivity testing for CRP among patients with NSTEMACS ( $n = 917$ ) enrolled in Fragmin During Instability in Coronary Artery Disease trial. (Data are from ref. 11.)



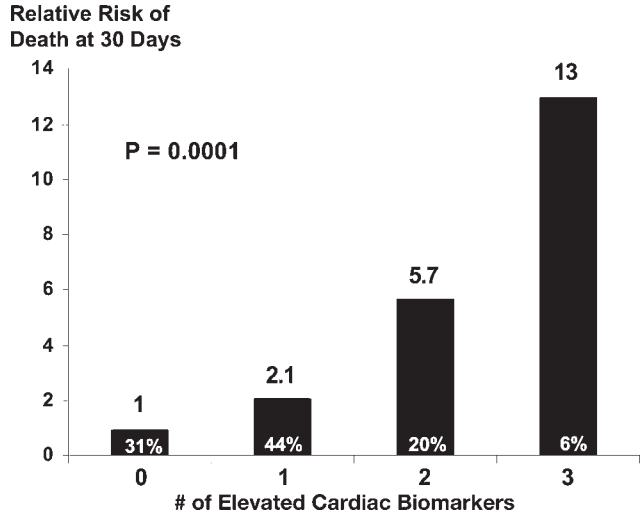
**Fig. 5.** Risk of death or MI at 30 d stratified by BNP and cTnI results among patients ( $n = 1676$ ) enrolled in the Treat with Aggrastat and Determine the Cost of Therapy with an Invasive or Conservative Strategy (TACTICS)-TIMI 18 Trial. (Used with permission from ref. 18.)

negative cTnI who had elevated BNP, the risk of death or MI was 7.5%, whereas in those with a negative BNP detected as being at higher risk only by cTnI, the risk of death or MI through 30 days was 6.4%. Patients with both a negative BNP and cTnI were at very low risk of death (0.7%) or death or MI (2.0%). Similar observations were made with NT-proBNP in more than 6000 patients with NSTEMACS, among whom the quantile of baseline concentration of NT-proBNP showed a graded relationship with the risk of mortality through 1 yr (19). Notably, patients with a level of NT-proBNP <237 pg/mL were at low risk of death regardless of troponin result.

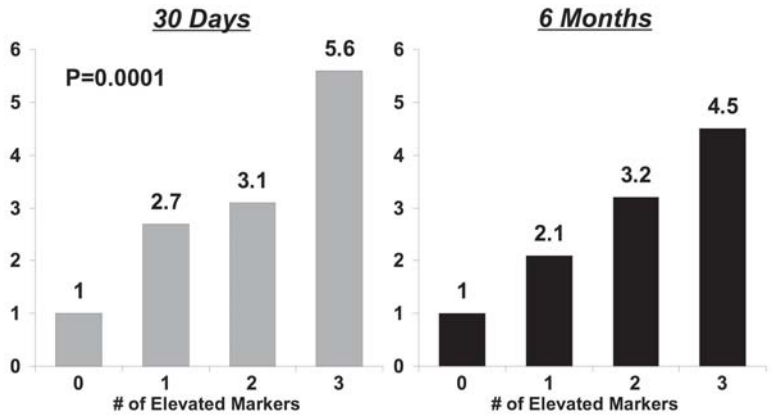
**MULTIMARKER APPROACHES USING THREE OR MORE MARKERS**

***Proof of Concept: CRP, BNP, and Troponin***

Given the evidence for the independent prognostic value of the three widely available, conveniently measured biomarkers CRP, BNP, and troponin, my colleagues and I explored



**Fig. 6.** Relative risk (RR) of death at 30 d using multimarker strategy in which patients are stratified by number of elevated biomarkers among a panel of cTnI, BNP, and hsCRP applied among patients enrolled in TACTICS-TIMI 18 Trial. (Data are from ref. 38.)



**Fig. 7.** RR of composite end point of death, MI, or new CHF at 30 d and 6 mo of follow-up in TACTICS-TIMI 18 stratified using combination of cTnI, BNP, and hsCRP. (Data are from ref. 38.)

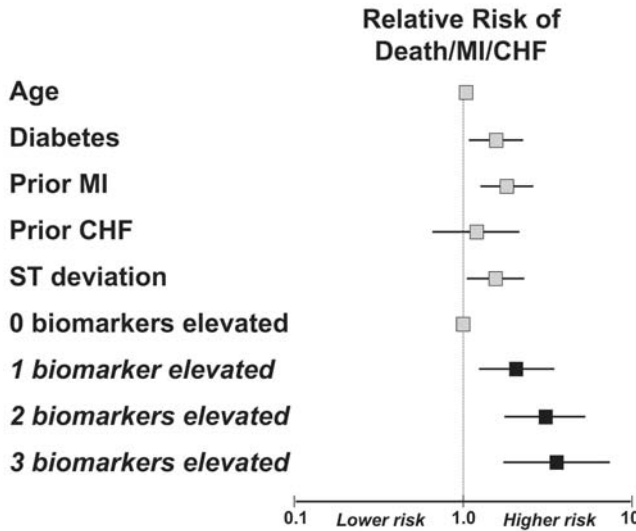
the hypothesis that application of multiple pathobiologically distinct markers would offer complementary information for assessment of risk among patients presenting with ACS. Using a simple strategy combining BNP, CRP, and cTnI and assigning one point for each elevated marker, we found that a multimarker approach enhanced risk stratification, establishing a more than 10-fold gradient of mortality risk among 1635 patients with NSTEMI/ACS (Fig. 6) (38). This strategy was consistent with respect to risk prediction at 30 d and 6–10 mo, as well as across two independent data sets (Fig. 7). Although the risk relationships were not entirely homogeneous, a graded pattern of risk was present for the individual end points of death, MI, and heart failure (Table 1). After adjustment for age, diabetes, ST-deviation, history of heart failure, and prior MI, each multimarker category (one, two, or three markers elevated) was independently associated with the risk of death, MI, or new heart failure at 6 mo (Fig. 8). These observations provided an important proof

**Table 1**  
**RR of Clinical Events Using Multimarker Strategy<sup>a</sup>**

<i>End point<sup>b</sup></i>	<i>No. of elevated biomarkers (cTnI, BNP, hsCRP)</i>				<i>p Value</i>
	<i>0</i>	<i>1</i>	<i>2</i>	<i>3</i>	
30 d					
MI	1.0	2.6	2.9	1.9	0.03
CHF	1.0	1.8	3.2	7.3	0.0046
D/MI	1.0	2.9	3.6	5.1	0.0001
6 mo					
MI	1.0	1.8	2.3	1.1	0.06
CHF	1.0	2.6	4.7	8.4	0.0001
D/MI	1.0	2.0	3.2	4.4	0.0001

<sup>a</sup>Data are from ref. 38.

<sup>b</sup>D/MI, composite of death or MI.

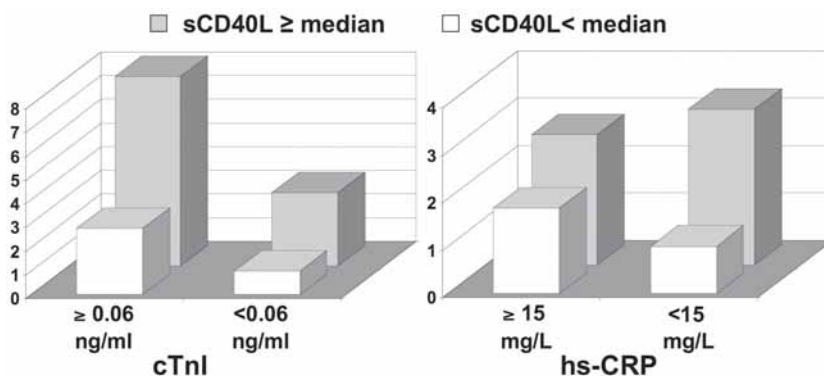


**Fig. 8.** Adjusted hazard rate ratio for risk of death, MI, or new CHF at 6 mo of follow-up in TACTICS-TIMI 18. (Data are from ref. 38.)

of concept for the value of a multimarker strategy for risk stratification using a practical approach that is likely to evolve with advances in the understanding of the individual risk relationships as well as the emergence of new markers (2).

**Other Novel Markers**

It is possible that other biomarkers, such as soluble CD40L (sCD40L), metalloproteinases, MPO, and possibly a marker of ischemia, will be added to or replace the three biomarkers (troponin, BNP, and CRP) that have been most extensively studied to date. Those biomarkers that capture novel information or reflect processes other than necrosis and hemodynamic stress are likely to be most useful; in particular, any candidates that prove to offer greater specificity for inflammation in the vasculature than CRP are likely to be extremely valuable.



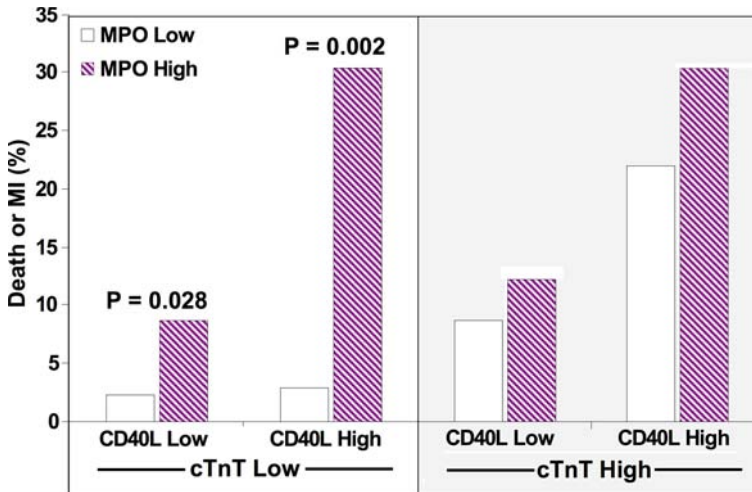
**Fig. 9.** Adjusted hazard rate ratio (HR) for risk of death or MI at 10 mo among case subjects ( $n = 195$ ) and control subjects ( $n = 195$ ) enrolled in Oral Glycoprotein IIb/IIIa Inhibition with Orbofiban in Patients with Unstable Coronary Syndromes-TIMI 26 Trial stratified by sCD40L, cTnI, and hsCRP. (Data are from ref. 39.)

sCD40L appears to reflect both inflammatory processes underlying plaque disruption and platelet activation, two critical contributors to atherothrombosis (*see* Chapter 18). Applied in conjunction with either CRP or cardiac troponin, sCD40L provides incremental information with respect to the risk of death or recurrent ischemic events in patients with ACS (Fig. 9) (39). MPO is an enzyme released during leukocyte degranulation and posited to play an adverse role in atherothrombosis via activation of metalloproteinases and, possibly, consumption of the endogenous vasodilator nitric oxide. The concentration of MPO is increased in some patients with unstable angina and appears to confer prognostic information in patients with ACS that is additive to both cardiac troponin and sCD40L (Fig. 10), and attenuates the predictive value of CRP when considered concurrently (40).

If the prognostic importance of these markers is validated in additional data sets, and analytic benchmarks (e.g., sample types, analytic conditions, optimal cut points, biological variation) can be met, multimarker strategies incorporating these markers will have a strong potential for clinical application. In addition, proteomic and genomic strategies for novel marker discovery (*see* Chapters 33 and 34) are likely to extend the list of candidate markers.

### *Approaches to Modeling*

The multimarker strategies described in the preceding sections have been based entirely on either dichotomized or categorical (quartiles) interpretation of biomarker results. For biomarkers with graded linear or even nonlinear relationships with risk, consideration of the absolute concentration is likely to offer incremental information compared to a simple categorization as “positive” or “negative.” However, interpretation of multiple biomarker results together as continuous variables substantially increases the complexity of reporting to the clinician and may fail to integrate the information in a manner that provides a useful overall assessment. For example, should the biomarker results of a patient with a BNP of 240 pg/mL, cTnI of 0.5 ng/mL, and hsCRP of 0.6 mg/L be reported exactly as such, or as BNP positive/cTnI positive/CRP negative, or as a multimarker score equal to 2? More sophisticated modeling approaches, such as based on neural network analysis, may be employed to transform the absolute concentrations into a single composite score. Such an approach has the advantage of being simple for the clinician to implement but



**Fig. 10.** Risk of death or MI at 6 mo stratified by cTnT (threshold: 0.01  $\mu\text{g/L}$ ), sCD40L (threshold: 5  $\mu\text{g/L}$ ), and MPO (threshold: 350  $\mu\text{g/L}$ ) among patients enrolled in c7E3 Anti-Platelet Therapy in Unstable Refractory Angina Trial and allocated to placebo ( $n = 547$ ). (Data are from ref. 40.)

Table 2  
Challenges in Developing a Multimarker Strategy

- It requires adequate clinical and analytic validation of each individual biomarker, including determination of appropriate sample handling, analytic performance, biological variability, and clinical decision limits.
- Relationship between the biomarker and the risk of specific clinical events may differ; that is, not all biomarkers are associated with the same clinical events with equal strength.
- Dichotomization of biomarker results may be overly simple and even misleading with respect to the magnitude of risk.
- Complex modeling is likely to hinder clinical application, whereas an overly simplified formulation may limit the validity and discriminatory capacity of the strategy.
- Evidence regarding the implications for therapy is critical to guiding clinical implementation.

may not be sufficiently flexible to provide the clinician with the information necessary to make decisions regarding therapy (*see* the next section).

### FACING THE COMPLEXITY OF A MULTIMARKER STRATEGY

Despite promising initial data, there are a number of challenges that have yet to be navigated in developing multimarker strategies that are viable for clinical use (*see* Table 2). In particular, the lack of entirely uniform relationships between each biomarker and the risk of specific clinical events has implications both for how the markers might be weighted in risk assessment and for the therapeutic response.

#### *Heterogeneity of Risk Relationships*

Although composite clinical end points are frequently employed in the evaluation of new biomarkers, the relationship between the biomarker and the risk of individual elements of that end point are not necessarily homogeneous. For example, troponin exhibits a near-linear graded relationship between concentration and the risk of death but appears

to have a nonmonotonic relationship (inverted U shape) with the risk of recurrent MI such that those with the highest levels of troponin with the index event are at lower risk of recurrent MI (41). Thus, troponin is a strong predictor of the risk of death and recurrent ischemic events and exhibits a threshold to the risk relationship at the lower limit of detection (42). By contrast, the relationship between BNP and CRP with the risk of recurrent ischemic events is less certain and the correlation with mortality is graded (with less of a clear-cut threshold than troponin) (18,19,31). The possibility of underascertainment of recurrent ischemia at the time of death in clinical studies must be recognized. Nevertheless, the more modest relationship between these markers and nonfatal recurrent ischemic events is consistent across several studies.

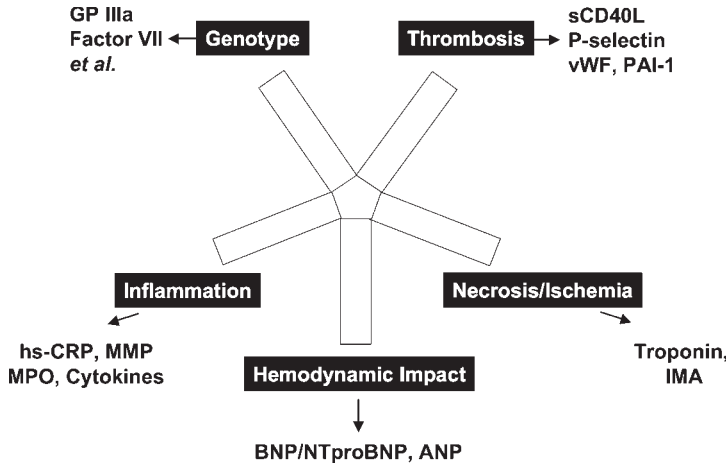
In light of this complexity, a multimarker strategy that is “positive” for one marker appears to have different implications with respect to the risk of recurrent MI if the elevated marker is CRP, e.g., rather than troponin. Similarly, a patient with elevated levels of BNP and CRP is likely at significantly increased risk of death via mechanical failure but without a substantially increased risk of recurrent MI. In addition to differences in the strength of the relationship with alternative end points, biomarkers may also exhibit a variety of patterns to the relationship (e.g., threshold, linear, or nonlinear). In this situation, application of a dichotomous cut point fails to capture all of the prognostic potential for a biomarker exhibiting a linear relationship. For example, given a stepwise relationship between increasing levels of BNP and NT-proBNP and mortality risk, the clinician should be aware that absolute plasma concentration of BNP carries additional information with respect to the magnitude of risk (e.g., the 6-mo mortality risk with a BNP of 80–100 pg/mL is 3.6 vs 10.9% for a BNP of 120–160 pg/mL).

Although as yet untested, it may be possible to reflect this complexity more accurately by weighting individual biomarkers differently for specific end points of interest and for different ranges of concentration. However, the advantages of such a modification are counterbalanced by the desire to maintain ease of application. Ultimately, the value of attempts at more complex weighting will be determined by careful evaluation of the application of such models for therapeutic decision making.

### *Implications for Therapy*

Despite strong evidence for the prognostic value of the newer markers, such as BNP and CRP, their integration into clinical practice has not become widespread. The primary determinant of this pace of integration has been the absence of guidance regarding the appropriate therapeutic response. Although therapies that mitigate the risk of an elevated level of troponin in patients with suspected ACS are well defined, to date there is not a consistent base of evidence to guide treatment in response to elevated levels of BNP or CRP.

An intense effort is under way to identify therapies directed at the inflammation underlying plaque instability in patients with ACS. Laboratory and clinical studies have revealed anti-inflammatory effects of established treatments aimed at other contributors to atherothrombosis (e.g., aspirin, statins, angiotensin-converting enzyme inhibitors and clopidogrel) (43). The evidence for anti-inflammatory actions of statins continues to grow and supports intensive statin therapy as being particularly important for patients with evidence of inflammation (44). In addition, clopidogrel decreases the expression of CD40L and may have a greater impact on reducing ischemic events after percutaneous coronary intervention in patients with elevated markers of inflammation (45). Agonists of the protein peroxisome proliferator activated receptor- $\alpha$  (PPAR- $\alpha$ ), such as fibric acid derivatives, can



**Fig. 11.** Conceptual application of multimarker approach to characterization of patient with ACS. ANP, atrial natriuretic peptide; GP, glycoprotein; IMA, ischemia-modified albumin; MMP, metalloproteinases; PAI-1, plasminogen activator inhibitor-1; vWF, von Willebrand factor. (Adapted from ref. 2.)

reduce the expression of adhesion molecules on vascular endothelial cells, inhibit T-lymphocyte function, improve vascular reactivity, and reduce production of the potent pro-coagulant tissue factor. Likewise, the family of insulin-sensitizing thiazolidinediones, which act through PPAR- $\gamma$ , are now appreciated to exert anti-inflammatory actions and reduce CRP as well as other inflammatory mediators in patients with diabetes (9). These and other treatments may eventually prove to be useful in modifying the risk associated with elevated levels of markers of inflammation.

Similar investigation targeted at reducing the risk associated with increased concentrations of natriuretic peptides is not as far advanced. Since BNP levels are associated with LV dysfunction as well as the extent of coronary artery disease, it is reasonable to hypothesize that early invasive evaluation and revascularization will reduce the risk linked to higher levels of BNP. However, the available data addressing this hypothesis have been conflicting (*see* Chapter 24) (18). It is also plausible that agents with favorable long-term effects on LV performance in patients with ischemic heart disease may prove beneficial in this population. At this point, natriuretic peptides may be used to identify patients at increased absolute risk of death and heart failure who have the most to gain from treatments that modify the risk of these events. However, additional research is necessary to test the success of specific interventions for patients with increased levels of BNP.

## CONCLUSION

The clinical application of cardiac biomarkers in patients with ACS is no longer limited to establishing or refuting the diagnosis of myocardial necrosis. Cardiac biomarkers provide a convenient and noninvasive avenue by which to profile the patient with ACS and more completely gain insight into the underlying causes and consequences of ACS that mediate the risk of recurrent events and may be targets for therapeutic interventions (Fig. 11). As the understanding of the pathogenesis of ACS advances and new markers and therapies are discovered, a multimarker strategy using a combination of markers for risk assessment and clinical decision making has the potential to improve outcomes in patients with ACS.

## REFERENCES

1. Karmen A, Wroblewski F, LaDue JS. Transaminase activity in human blood. *J Clin Invest* 1955;34:126–131.
2. Morrow DA, Braunwald E. Future of biomarkers in acute coronary syndromes: moving toward a multimarker strategy. *Circulation* 2003;108:250–252.
3. Braunwald E. Unstable angina: a classification. *Circulation* 1989;80:410–414.
4. Braunwald E. Unstable angina: an etiologic approach to management. *Circulation* 1998;98:2219–2222.
5. Morrow DA. Troponins in patients with acute coronary syndromes: biologic, diagnostic, and therapeutic implications. *Cardiovasc Toxicol* 2001;1:105–110.
6. Wong GC, Morrow DA, Murphy S, et al. Elevations in troponin T and I are associated with abnormal tissue level perfusion: a TACTICS-TIMI 18 substudy. *Treat Angina with Aggrastat and Determine Cost of Therapy with an Invasive or Conservative Strategy-Thrombolysis in Myocardial Infarction*. *Circulation* 2002;106:202–207.
7. Morrow DA, Antman EM, Tanasijevic M, et al. Cardiac troponin I for stratification of early outcomes and the efficacy of enoxaparin in unstable angina: a TIMI 11B substudy. *J Am Coll Cardiol* 2000;36:1812–1817.
8. Hamm CW, Heeschen C, Goldmann B, et al. Benefit of abciximab in patients with refractory unstable angina in relation to serum troponin T levels. c7E3 Fab Antiplatelet Therapy in Unstable Refractory Angina (CAPTURE) Study Investigators. *N Engl J Med* 1999;340:1623–1629.
9. Libby P, Ridker PM, Maseri A. Inflammation and atherosclerosis. *Circulation* 2002;105:1135–1143.
10. Morrow DA, Rifai N, Antman EM, et al. C-reactive protein is a potent predictor of mortality independently of and in combination with troponin T in acute coronary syndromes: a TIMI 11A substudy. *Thrombolysis in Myocardial Infarction*. *J Am Coll Cardiol* 1998;31:1460–1465.
11. Lindahl B, Toss H, Siegbahn A, Venge P, Wallentin L. Markers of myocardial damage and inflammation in relation to long-term mortality in unstable coronary artery disease. FRISC Study Group. *Fragmin during Instability in Coronary Artery Disease*. *N Engl J Med* 2000;343:1139–1147.
12. Pasceri V, Willerson JT, Yeh ET. Direct proinflammatory effect of C-reactive protein on human endothelial cells. *Circulation* 2000;102:2165–2168.
13. de Lemos JA, Morrow DA. Brain natriuretic peptide measurement in acute coronary syndromes: ready for clinical application? *Circulation* 2002;106:2868–2870.
14. Richards AM, Nicholls MG, Yandle TG, et al. Plasma N-terminal pro-brain natriuretic peptide and adrenomedullin: new neurohormonal predictors of left ventricular function and prognosis after myocardial infarction. *Circulation* 1998;97:1921–1929.
15. de Lemos JA, Morrow DA, Bentley JH, et al. The prognostic value of B-type natriuretic peptide in patients with acute coronary syndromes. *N Engl J Med* 2001;345:1014–1021.
16. Omland T, de Lemos JA, Morrow DA, et al. Prognostic value of N-terminal pro-atrial and pro-brain natriuretic peptide in patients with acute coronary syndromes. *Am J Cardiol* 2002;89:463–465.
17. Jernberg T, Stridsberg M, Venge P, Lindahl B. N-terminal pro brain natriuretic peptide on admission for early risk stratification of patients with chest pain and no ST-segment elevation. *J Am Coll Cardiol* 2002;40:437–445.
18. Morrow DA, de Lemos JA, Sabatine MS, et al. Evaluation of B-type natriuretic peptide for risk assessment in unstable angina/non-ST elevation MI: BNP and prognosis in TACTICS-TIMI 18. *J Am Coll Cardiol* 2003;41:1264–1272.
19. James SK, Wallentin L, Armstrong PW, et al. N-terminal pro brain natriuretic peptide and other risk markers for the separate prediction of mortality and subsequent myocardial infarction in patients with unstable coronary disease—a GUSTO IV substudy. *Circulation* 2003;108:275–281.
20. Newby LK, Storrow AB, Gibler WB, et al. Bedside multimarker testing for risk stratification in chest pain units: the chest pain evaluation by creatine kinase-MB, myoglobin, and troponin I (CHECKMATE) study. *Circulation* 2001;103:1832–1837.
21. de Lemos JA, Morrow DA, Gibson CM, et al. The prognostic value of serum myoglobin in patients with non-ST-segment elevation acute coronary syndromes: results from the TIMI 11B and TACTICS-TIMI 18 studies. *J Am Coll Cardiol* 2002;40:238–244.
22. McCord J, Nowak RM, McCullough PA, et al. Ninety-minute exclusion of acute myocardial infarction by use of quantitative point-of-care testing of myoglobin and troponin I. *Circulation* 2001;104:1483–1488.
23. Haverkate F, Thompson SG, Pyke SD, Gallimore JR, Pepys MB. Production of C-reactive protein and risk of coronary events in stable and unstable angina. European Concerted Action on Thrombosis and Disabilities Angina Pectoris Study Group. *Lancet* 1997;349:462–466.



24. Toss H, Lindahl B, Siegbahn A, Wallentin L. Prognostic influence of increased fibrinogen and C-reactive protein levels in unstable coronary artery disease. FRISC Study Group. Fragmin during Instability in Coronary Artery Disease. *Circulation* 1997;96:4204–4210.
25. Rebuzzi AG, Quaranta G, Liuzzo G, et al. Incremental prognostic value of serum levels of troponin T and C-reactive protein on admission in patients with unstable angina pectoris. *Am J Cardiol* 1998;82:715–719.
26. Tommasi S, Carluccio E, Bentivoglio M, et al. C-reactive protein as a marker for cardiac ischemic events in the year after a first, uncomplicated myocardial infarction. *Am J Cardiol* 1999;83:1595–1599.
27. Ferreiros ER, Boissonnet CP, Pizarro R, et al. Independent prognostic value of elevated C-reactive protein in unstable angina. *Circulation* 1999;100:1958–1963.
28. Biasucci L, Liuzzo G, Grillo R, et al. Elevated levels of C-reactive protein at discharge in patients with unstable angina predict recurrent instability. *Circulation* 1999;99:855–860.
29. Heeschen C, Hamm CW, Bruemmer J, Simoons ML. Predictive value of C-reactive protein and troponin T in patients with unstable angina: a comparative analysis. CAPTURE Investigators. Chimeric c7E3 Anti-Platelet Therapy in Unstable angina REfractory to standard treatment trial. *J Am Coll Cardiol* 2000;35:1535–1542.
30. Mueller C, Buettner HJ, Hodgson JM, et al. Inflammation and long-term mortality after non-ST elevation acute coronary syndrome treated with a very early invasive strategy in 1042 consecutive patients. *Circulation* 2002;105:1412–1415.
31. James SK, Armstrong P, Barnathan E, et al. Troponin and C-reactive protein have different relations to subsequent mortality and myocardial infarction after acute coronary syndrome: a GUSTO-IV substudy. *J Am Coll Cardiol* 2003;41:916–924.
32. Arakawa N, Nakamura M, Aoki H, Hiramori K. Plasma brain natriuretic peptide concentrations predict survival after acute myocardial infarction. *J Am Coll Cardiol* 1996;27:1656–1661.
33. Omland T, Aakvaag A, Bonarjee VV, et al. Plasma brain natriuretic peptide as an indicator of left ventricular systolic function and long-term survival after acute myocardial infarction: comparison with plasma atrial natriuretic peptide and N-terminal proatrial natriuretic peptide. *Circulation* 1996;93:1963–1969.
34. Talwar S, Squire IB, Downie PF, et al. Profile of plasma N-terminal proBNP following acute myocardial infarction: correlation with left ventricular systolic dysfunction. *Eur Heart J* 2000;21:1514–1521.
35. Omland T, Persson A, Ng L, et al. N-terminal pro-B-type natriuretic peptide and long-term mortality in acute coronary syndromes. *Circulation* 2002;106:2913–2918.
36. Jernberg T, Lindahl B, Siegbahn A, et al. N-terminal pro-brain natriuretic peptide in relation to inflammation, myocardial necrosis, and the effect of an invasive strategy in unstable coronary artery disease. *J Am Coll Cardiol* 2003;42:1909–1916.
37. Omland T, de Lemos JA, Morrow DA, et al. Prognostic value of N-terminal pro-atrial and pro-brain natriuretic peptide in patients with acute coronary syndromes: a TIMI 11B substudy. *Am J Cardiol* 2002;89:463–465.
38. Sabatine MS, Morrow DA, de Lemos JA, et al. Multimarker approach to risk stratification in non-ST elevation acute coronary syndromes: simultaneous assessment of troponin I, C-reactive protein, and B-type natriuretic peptide. *Circulation* 2002;105:1760–1763.
39. Varo N, de Lemos JA, Libby P, et al. Soluble CD40L: risk prediction after acute coronary syndromes. *Circulation* 2003;108:1049–1052.
40. Baldus S, Heeschen C, Meinertz T, et al. Myeloperoxidase serum levels predict risk in patients with acute coronary syndromes. *Circulation* 2003;108:1440–1445.
41. Lindahl B, Diderholm E, Lagerqvist B, Venge P, Wallentin L. Mechanisms behind the prognostic value of troponin T in unstable coronary artery disease: a FRISC II substudy. *J Am Coll Cardiol* 2001;38:979–986.
42. Morrow DA, Cannon CP, Rifai N, et al. Ability of minor elevations of troponin I and T to identify patients with unstable angina and non-ST elevation myocardial infarction who benefit from an early invasive strategy: results from a prospective, randomized trial. *JAMA* 2001;286:2405–2412.
43. Libby P, Aikawa M. Stabilization of atherosclerotic plaques: new mechanisms and clinical targets. *Nat Med* 2002;8:1257–1262.
44. Ridker PM, Cannon CP, Morrow D, et al. C-reactive protein levels and outcomes after statin therapy. *N Engl J Med* 2005;352:20–28.
45. Bhatt DL, Topol EJ. Need to test the arterial inflammation hypothesis. *Circulation* 2002;106:136–140.

# 32

---

## Cardiac Biomarkers by Point-of-Care Testing

---

*Paul O. Collinson, MD, FRCPath, FACB*

### CONTENTS

INTRODUCTION

CLINICAL SCENARIOS

METHODOLOGICAL ASPECTS

RATIONALE FOR POC TESTING

CLINICAL APPLICATIONS OF POC TESTING:

EVIDENCE BASE FOR CARDIAC POC TESTING

CONCLUSION

REFERENCES

---

### SUMMARY

Point-of-care (POC) testing offers the opportunity to provide more rapid measurement of cardiac biomarkers in the environment in which clinical decisions about patient management are made. The technology of POC testing utilizes whole blood to measure one or more analytes including cardiac biomarkers such as creatine kinase-MB isoenzyme, myoglobin, cardiac troponins T and I, and B-type natriuretic peptide. Measurement methods include immunochromatographic separation usually combined with a quantitative reader, dedicated heterogeneous immunoassay systems, and those suitable for POC and emergency laboratory testing. Analytic performance of these systems approaches but does not always equal those of conventional laboratory methods. Evaluation of POC testing of cardiac biomarker measurement has shown good analytic and clinical diagnostic performance. These systems are entirely suitable for rule-in diagnosis of myocardial infarction (MI). Although POC testing has also been shown to be suitable for rule-out strategies, there is a lack of studies comparing POC testing with laboratory measurements for diagnosis using updated criteria for acute MI or for prognosis. Although POC testing is faster, there is only limited evidence that the speed and convenience of these systems can have a direct impact on outcome measures such as treatment selection or length of stay. More work is needed in this area.

**Key Words:** Cardiac biomarkers; point-of-care testing; evidence-based medicine; cardiac troponin T; cardiac troponin I; myoglobin; B-type natriuretic peptide.

From: *Contemporary Cardiology:  
Cardiovascular Biomarkers: Pathophysiology and Disease Management*  
Edited by: David A. Morrow © Humana Press Inc., Totowa, NJ

## INTRODUCTION

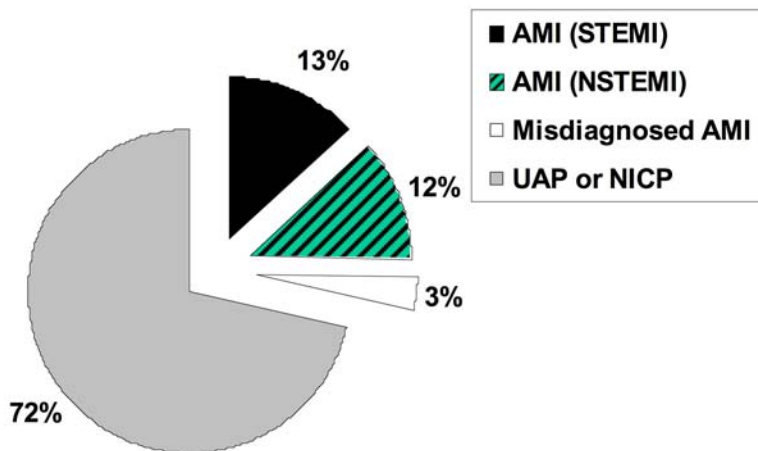
Coronary artery disease commences with plaque development and clinically manifests with the effects of lumen occlusion, which in the majority of cases is owing to plaque destabilization by either rupture or erosion and the development of platelet aggregates (1–3). Biomarkers to assess all stages of this process are available. The risk of plaque development and destabilization may be assessed by measurement of lipoproteins, apolipoproteins, and high-sensitivity C-reactive protein. The consequences of acute plaque rupture may be assessed by measuring markers of cardiomyocyte necrosis such as cardiac troponin (4,5). The impact of ischemic disease and myocardial damage on cardiac performance can be assessed by markers of cardiomyocyte function such as B-type natriuretic peptide (BNP).

The measurement of cardiac biomarkers is part of routine clinical practice. It is the need for rapid and convenient clinical application (real or perceived) that has driven the development of point-of-care (POC) testing for cardiac biomarkers. Any assessment of POC testing for cardiac biomarkers must therefore consider the clinical situations to which POC testing can be applied, methodological aspects (6), the rationale for use, and the evidence base. This application must then be compared with the conventional approach using central laboratory testing (CLT).

## CLINICAL SCENARIOS

Current management of patients with acute coronary syndrome (ACS) and breathlessness is based on a combination of clinical features, electrocardiogram (ECG), chest radiograph, and cardiac biomarkers. Initial categorization uses the ECG to divide patients into those with definitive changes such as ST-elevation, those with less specific changes such as ST-segment depression or T wave inversion, and those with no ECG abnormality. Patients with appropriate clinical features and ST-elevation ACS are categorized as ST-elevation myocardial infarction (STEMI). Management is based on immediate opening of the occluded artery by primary angioplasty or thrombolysis (7). Elevation of biomarkers such as cardiac troponin (8,9) at presentation or BNP (10–12) identifies a high-risk subset. To date, there are no clinically proven strategies that show these patients should be treated differently. Therefore, it is considered that immediate biomarker measurement will not alter patient management (7). Patients without STEMI will have a final diagnosis based on clinical features, ECG findings, and cardiac troponin measurement. In the general chest pain population, only a minority of patients present with STEMI, the majority having either low-risk unstable angina or nonischemic chest pain (Fig. 1) (13).

The clinical pathway of patients without STEMI is determined by biomarker measurement to define diagnosis and subsequent management strategy (14). There are three categories of patients that need to be identified. Patients with elevated troponin, nonspecific ECG changes, and appropriate clinical features have non-STEMI (NSTEMI). Exclusion of NSTEMI is followed by further investigation to identify those patients with undetectable troponin, nonspecific ECG changes, and appropriate clinical features who have unstable angina pectoris and those with a final diagnosis of nonischemic chest pain. The clinical environment in which diagnostic categorization occurs depends on the perceived risk of the patients. Patients considered at high risk of ischemic heart diseases are managed in a cardiac care environment whereas those at lower risk are managed in the emergency department (ED) or a chest pain evaluation unit. The difference is usually in the length of observation and intensity of the subsequent investigations.



**Fig. 1.** Distribution of patients by final diagnostic category in patients admitted with chest pain and suspected ACS. UAP, low-risk unstable angina pectoris; NICP, nonischemic chest pain. (Data are adapted from ref. 13.)

## METHODOLOGICAL ASPECTS

The current available technology for POC testing can be divided into three categories (Table 1): visually read test devices, dedicated POC instruments, and instruments suitable for either POC testing or use in the emergency/stat laboratory. The first developments in cardiac POC testing evolved from glucose test strip methodology using initially serum, then whole-blood measurements of creatine kinase (CK) and its MB isoenzyme (CK-MB). These methods were superseded by the development of immunoassay formats based on whole-blood separation and antigen-antibody complex formation, streptavidin-biotin binding of the complex, and visual detection. The antibody is labeled with gold (gold-labeled optically read immunoassay [GLORIA]) or a dye. This produced the first generation of POC testing cardiac marker testing, often referred to as “stick” testing (Fig. 2). Although visually read test devices have been shown to be suitable for routine clinical use, they are more prone to operator error. Visually read strip tests are best used together with optical reading systems. This improves both precision and assay detection limit. The use of a fluorescent-labeled detection antibody employing this type of technology means that the test strip cannot be read visually but requires a dedicated reader.

The limitation of POC testing cardiac marker testing is the analytic performance. The majority of dedicated POC testing instruments have detection limits and analytic coefficients of variation (CVs) that, although acceptable, are not as good as those of laboratory instruments. There is one further caveat. Published studies of POC testing instruments are based on studies in a controlled environment by laboratory staff or a small number of trained (often enthusiastic) operators. In routine clinical use, this is not the case. POC testing is carried out by a range of nonlaboratory-trained staff. In a comparative assessment of POC testing with CLT, we found that the analytical CV was equivalent to specification when undertaken by a laboratory scientist but doubled when the same analyses were performed by nonlaboratory-trained personnel. Finally, if considering POC testing, it is important that the results produced have similar (ideally identical) clinical cutoffs to values produced by the central laboratory. This is less of a problem for myoglobin, CK-MB, BNP, and cardiac troponin T (cTnT) but is a potential source of confusion for cardiac troponin

**Table 1**  
**Point-of-Care Cardiac Marker Assays: Technology, Performance, and Assay Characteristics**

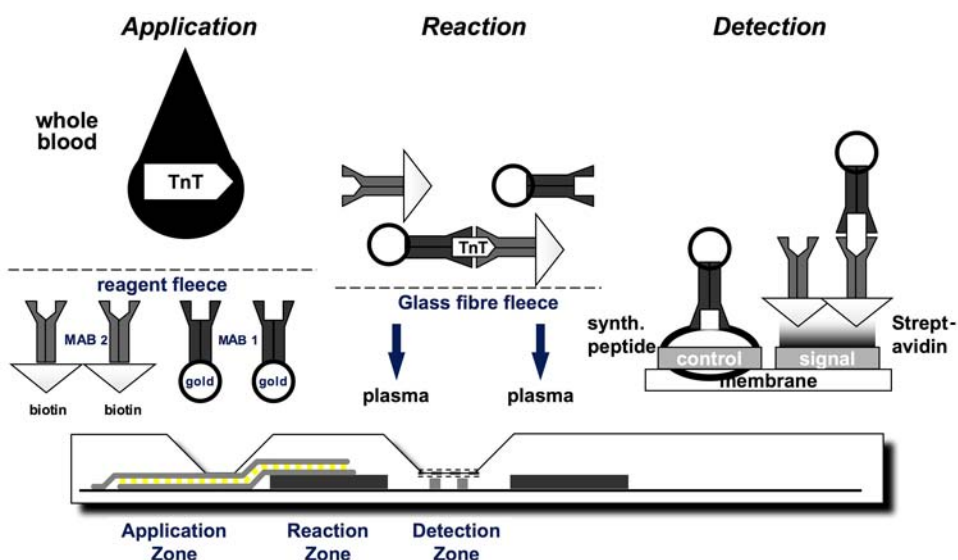
<i>Supplier &amp; instrument</i>	<i>Assay type</i>	<i>Antibodies</i>	<i>Sample type</i>	<i>Sample volume μL</i>	<i>Sample storage</i>	<i>Imprecision (% CV)</i>	<i>Sensitivity</i>	<i>Upper measuring limit</i>	<i>Calibration</i>	<i>Reference values μg/L</i>	<i>AMI cut-off μg/L</i>	<i>Assay time</i>	<i>Correlation to other methods</i>
Spectral Diagnostics Inc. Spectral cartridges cTnI	Solid phase chromatographic immunoassay (Visually read)	Monoclonal anti-cTnI dye conjugate. Polyclonal biotinylated anti-cTnI.	Heparinized whole blood or plasma, serum	200	Whole blood within 4 h. Plasma 24 h at 2–8°C, >24 h at –20°C	Qualitative results	1.5 μg/L	No data	Not stated	<1.5	>1.5	15	Not stated
Spectral Diagnostics Inc. Spectral cartridges CK-MB	Solid phase chromatographic immunoassay (Visually read)	Monoclonal anti-CK-MB dye conjugate. Polyclonal biotinylated anti-CK-MB.	Heparinized whole blood or plasma, serum	200	Whole blood within 4 h. Plasma 24 h at 2–8°C, >24 h at –20°C	Qualitative results	5 μg/L	No data	Not stated	<5	>5	15	Not stated
Spectral Diagnostics Inc. Spectral cartridges Myoglobin	Solid phase chromatographic immunoassay (Visually read)	Monoclonal anti-myoglobin dye conjugate. Polyclonal biotinylated anti-myoglobin.	Heparinized whole blood or plasma, serum	200	Whole blood within 4 h. Plasma 24 h at 2–8°C, >24 h at –20°C	Qualitative results	50 μg/L	No data	Not stated	<50	>50	15	Not stated
Roche Cardiac Reader cTnT	GLORIA 3rd generation cTnT (CardiacT) (Can be visually read but POCT instrument recommended)	Gold-labeled mouse Mab anti-cTnT. Mouse Mab biotinylated anti-cTnT.	Heparinized whole blood	150	8 h at room temp.	10–15% (POCT instrument)	0.1 μg/L	2.0 μg/L	Lot-specific master curve	Not stated	0.1	14	Agrees with Elecsys method
Roche Cardiac Reader Myoglobin	GLORIA myoglobin (Cardiac M) (Can be visually read but POCT instrument recommended)	Gold-labeled mouse Mab anti-myoglobin. Mouse Mab biotinylated anti-myoglobin.	Heparinized whole blood	150	6 h at room temp.	5–10% (POCT instrument)	30 μg/L	700 μg/L	Lot-specific master curve	16–76 (M) 7–64 (F)		14	Agrees with Elecsys method
Biosite Triage cTnI	Fluorescence immunoassay (POCT instrument)	Mouse Mab and goat polyclonal anti-cTnI labeled with fluorescent dye and immobilized on the solid phase.	Heparinized whole blood or plasma	Not stated	24 h or plasma at –20°C until tested	Total imprecision 9.1–19.4%	0.19 μg/L	50 μg/L	Lot-specific master curve	<0.19	0.4	15	Not stated

Bosite Triage CK-MB	Fluorescence immunoassay (POCT instrument)	Mouse Mab and goat polyclonal anti-CK-MB labeled with fluorescent dye and immobilized on the solid phase.	Heparinized whole blood or plasma	Not stated	24 h or plasma at -20°C until tested	Total imprecision 9.4–12.0%	0.75 µg/L	125 µg/L	Lot-specific master curve	<4.3	4.3	15	Not stated
Bosite Triage Myoglobin	Fluorescence immunoassay (POCT instrument)	Mouse Mab and goat polyclonal anti-myoglobin labeled with fluorescent dye and immobilized on the solid phase.	Heparinized whole blood or plasma	Not stated	24 h or plasma at -20°C until tested	Total imprecision 9.9–16.3%	2.7 µg/L	500 µg/L	Lot-specific master curve	<107	107	15	Not stated
Biosite Triage BNP	Fluorescence immunoassay (POCT instrument)	Mouse Mab and anti-BNP PAb anti-BNP labeled with a fluorescent dye immobilized on the solid phase.	EDTA anti- coagulated whole blood or plasma	Not stated	4 h or plasma at -20°C until tested	Total imprecision 10.1–16.2%	5 pg/mL	1300 pg/mL	Lot-specific master curve	For all ages and genders: 73.5	N/A	15	Not stated
Response Biomedical RAMP Reader cTnI	Immunochem- atographic assay (Fluorescence immunoassay (POCT instrument)	Fluorescent- dyed latex beads coated with anti-cTnI Ab.	EDTA anti- coagulated whole blood	70	2 h from fresh or EDTA whole blood stored at 2–8°C for 5 d	Total imprecision 7.0–10.1%	0.16 µg/L	Not stated	Lot-specific master curve	<0.3	0.12	15	RAMP = 1.059 Stratus CS + 0.244
Response Biomedical RAMP Reader CK-MB	Immunochem- atographic assay (POCT instrument)	Fluorescent- dyed latex beads coated with anti- CKMB Ab.	EDTA anti- coagulated whole blood	70	2 h from fresh or EDTA whole blood stored at 2–8°C for 5 d	Total imprecision 6.3–8.0%	0.32 µg/L	Not stated	Lot-specific master curve	<8.40	Not stated	15	RAMP = 1.059 xRxL – 0.476
Response Biomedical RAMP Reader Myoglobin	Immunochem- atographic assay (POCT instrument)	Fluorescent- dyed latex beads coated with anti- myoglobin Ab.	EDTA anti- coagulated whole blood	70	2 h from fresh or EDTA whole blood stored at 2–8°C for 5 d	Total imprecision 10.4–14.3%	2.4 µg/L	Not stated	Lot-specific master curve	99.3	Not stated	15	Not stated

(continued)

Table 1 (Continued)

<i>Supplier &amp; instrument</i>	<i>Assay type</i>	<i>Antibodies</i>	<i>Sample type</i>	<i>Sample volume μL</i>	<i>Sample storage</i>	<i>Imprecision (% CV)</i>	<i>Sensitivity</i>	<i>Upper measuring limit</i>	<i>Calibration</i>	<i>Reference values μg/L</i>	<i>AMI cut-off μg/L</i>	<i>Assay time</i>	<i>Correlation to other methods</i>
i-STAT Corp. cTnI	Two site enzyme linked immunosorbent assay (POCT instrument)	Anti-cTnI immobilized on an electro-chemical sensor silicon chip. Anti-cTnI conjugated to alkaline phosphatase.	Heparinized whole blood or plasma	16	Not stated	Total imprecision 7.6–8.5%	0.02 μg/L	50 μg/L	Lot-specific master curve	0–0.03	0.1	10	ISTAT = 0.97 Stratus CS + 0.02
Dade Behring Stratus CS cTnI	Solid Radial Partition Immunoassay (POCT instrument)	Mouse MAb anti-cTnI conjugated to alkaline phosphatase. Dendrimer linked mouse MAb anti-cTnI.	Heparinized whole blood or plasma	90 (2 mL whole blood)	within 2 h fresh, 14 d at 2–8°C or 8 wk at –20°C	Total imprecision 3.4–5.1%	0.03 μg/L	50 μg/L	Lot-specific master curve	0.06	1.5	13	CS = 0.90 Stratus II + 0.12
Dade Behring Stratus CS CK-MB	Solid Radial Partition Immunoassay	Mouse MAb anti-CKBB conjugated to alkaline phosphatase. Dendrimer linked mouse MAb anti-CKMB.	Heparinized whole blood or plasma	90 (2 mL whole blood)	within 2 h fresh, 14 d at 2–8°C or 8 wk at –20°C	Total imprecision 3.2–4.1%	0.3 μg/L	150 μg/L	Lot-specific master curve	0.6–3.5	3.5	13	CS = 0.97 Stratus II + 0.65
Dade Behring Stratus CS Myoglobin	Solid Radial Partition Immunoassay	Mouse MAb anti-myoglobin Fab' conjugated to alkaline phosphatase. Dendrimer linked mouse MAb-anti myoglobin.	Heparinized whole blood or plasma	90 (2 mL whole blood)	within 2 h fresh, 14 d at 2–8°C or 8 wk at –20°C	Total imprecision 3.5–4.6%	1 μg/L	900 μg/L	Lot-specific master curve	21–98 (M) 19–56 (F) 20–82 (all)	50	13	CS = 0.97 StratusII + 8



**Fig. 2.** Immunochromatographic separation measurement of cTnT using gold-labeled antibodies (see text for details). MAB, monoclonal antibody.

I (cTnI). Either methods should be chosen that produce comparable cTnI values or the same method should be used in both POC testing and the central laboratory.

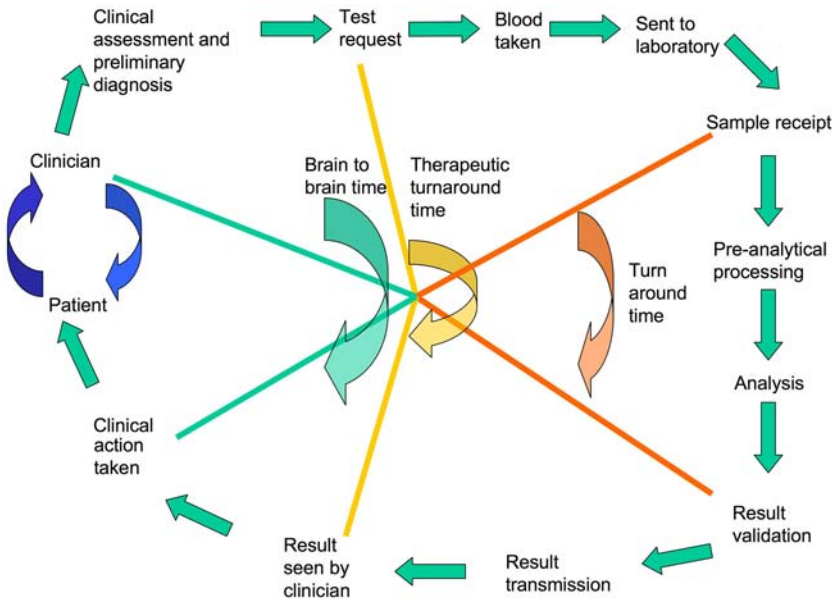
## RATIONALE FOR POC TESTING

POC testing offers two advantages over CLT: speed of results and convenience.

### *Is POC Testing Faster?*

In absolute terms, analytic time for CLT is actually faster than POC testing. Most modern analyzers can produce results within 10 min or less from the time the sample is loaded and will then produce results at 30-s intervals thereafter. The majority of POC testing systems have comparable or slightly longer analytic times of 10–15 min. In addition, although a POC testing system may have an analytic time of 15 min, because it analyzes only one sample at a time, the effective analytic throughput of 4 samples/h will be much slower than the 50 (or more) samples/h of typical laboratory systems. The reason that POC testing can be overall a faster strategy is that the delays in sample transport and processing prior to analysis are removed. Prospective studies of POC testing have clearly shown a reduction in time to availability of results from a median of 71 (CLT) to 20 min (POC testing) (15) or from 71 min (CLT) to 24 (POC testing) (16). Another factor of importance is the impact of the availability of results. Results from the central laboratory may be available but not viewed. The evaluation of CLT uses the concept of turnaround time, i.e., the time from sample arrival to production of results. This is a limited measure of performance because it does not account for delays in sample arrival and action taken on the results. This has led to the concept of the therapeutic turnaround time, i.e., the time from sample draw to action on the results (17), sometimes referred to as vein-to-brain time. The therapeutic turnaround time is a more accurate assessment of the time to decision, but a better measure is the “brain-to-brain” time, i.e., the time from the decision to order a test to the action taken on the result (Fig. 3).





**Fig. 3.** Schematic diagram of “brain-to-brain” time (*see* text for details).

Brain-to-brain time represents part of the process of clinical care. It is this clinical process that determines the speed with which patient diagnosis is made and the appropriate clinical actions are taken, and, therefore (it is hoped), clinical outcomes are improved and cost efficiency is obtained. The actual analytic turnaround time may be a small component in this process. If the decision-making pathway is not optimized to act on rapidly produced test results, the speed of production of results will not be the rate-limiting step.

The importance of the clinical process and process reengineering cannot be overestimated. This process is well illustrated in the evolution of chest pain units that offer an alternative strategy to conventional approaches for the management of chest pain. Prospective observational (18–20) and randomized studies (21,22) have shown that such an approach is clinically equivalent to conventional strategies, diagnostically efficient, and cost-effective. This improvement has been achieved by process reengineering rather than POC testing. Data support the concept that more rapid provision of laboratory results will have a direct impact on outcome measures, such as length of stay. In a prospective observational study of a rapid diagnostic cardiac enzyme policy compared with a conventional strategy, there was a significant reduction in mean length of stay in the cardiac care unit, from 3 to 2 d (23). Provision of a more frequent assay service showed a similar reduction (24). Conversely, a survey of hospitals found that a more rapid and frequent assay service was associated with reduced length of stay for patients with a diagnosis of AMI, not, as might be expected, the low-risk “rule-out” patient (25).

### *Convenience*

POC testing is an additional activity undertaken by staff for a service previously provided by the laboratory. In addition, it requires the POC testing instrument (Fig. 4) to be maintained and for a quality assurance program to be in place. There may, therefore, be more inconvenience, rather than less. The benefit comes from the speed of result return and the immediacy of availability of information. Although this advantage is intuitive,



**Fig. 4.** Available POC instruments (the CD next to the instruments is for perspective with respect to size): (A) Cardiac Reader (Roche Diagnostics, Indianapolis); (B) Triage (Biosite, San Diego, CA); (C) Stratus CS (Dade Behring, Newark, DE).

it is difficult to quantify. A systematic survey of ED staff before and after implementation of a rapid diagnostic service with a satellite laboratory (hence a rapid laboratory service rather than true POC testing) showed that the staff valued the improved service available from this “close to patient” testing service (26).

## CLINICAL APPLICATIONS OF POC TESTING: EVIDENCE BASE FOR CARDIAC POC TESTING

### *Biomarkers of Myocyte Necrosis: POC Testing for Suspected ACSs*

#### DIAGNOSIS

The role of POC testing in patients admitted with possible ACS is the same as that of laboratory testing: foremost, to confirm or exclude MI as a cause of cardiac chest pain. The visually read systems have been the subject of a number of clinical studies. A retrospective comparison of POC testing cTnT measurement with CLT showed 96% concordance in 191 tests with diagnostic sensitivity ranging from 17 to 71% according to time from presentation with diagnostic equivalence to CK-MB (27). In a prospective observational trial, serial blood samples were obtained on presentation to the ED and 3 and 6 h later in 721 patients. CLT and POC testing cTnT measurement had equivalent sensitivity for detection of AMI (28).

Comparison of 58 samples from 25 patients evaluated in the ED using the Spectral POC testing system showed diagnostically similar results to quantitative assays for CK-MB and myoglobin (29). A second study of 182 consecutive ED patients found that results were not as good as for quantitative assays (30). Clinical validation has been performed in a

number of studies in ED and coronary care unit (CCU) populations. In the ED, a study of 277 patients found that on serial testing over 3 h sensitivity was 95% for the diagnosis of AMI (31). In the CCU, three studies of, respectively, 101 (32), 99 (33), and 151 (34) patients demonstrated sensitivity in the range of 95–100%, with diagnostic efficiency superior to that of troponin testing alone in the first 6 h.

The diagnostic performance of the Roche cardiac reader, a quantitative reader that uses a charge-coupled device camera to read optically both Cardiac T strips and similar myoglobin strips (Cardiac M), has been shown to be comparable with that of the central laboratory, but with slightly lower diagnostic sensitivity (35–37). There are similar data for the Biosite Triage. The cardiac panel has been evaluated analytically and clinically with the decision threshold for AMI of 0.4  $\mu\text{g/L}$  for cTnI by receiver operating characteristic (ROC) curve analysis, equivalent to conventional laboratory testing for the diagnosis of AMI (38). The Spectral system measures myoglobin, CK-MB, and cTnI. The Stratus CS is essentially a laboratory instrument that can be used for point of care (39). Analytically, it is superior to all of the other systems.

### RISK STRATIFICATION

Small rises in CK-MB have been demonstrated to be prognostic (40,41), but measurement of cTnT and cTnI offers not only diagnostic specificity but superior sensitivity. Acceptable diagnostic performance has been shown for the available visually read systems. For cTnT, risk stratification was examined in a TIMI 11A substudy in which 597 patients enrolled had POC testing and simultaneous CLT of cTnT on study entry. Death, nonfatal MI, or recurrent ischemia at d 14 occurred in 33.6% of patients with a positive assay compared with only 22.5% of patients with a negative assay ( $p = 0.01$ ) (42). A GUSTO III substudy of 12,666 patients presenting with ST-segment elevation found that patients with a positive POC test of cTnT on admission had a 15.7% mortality at 30 d compared with 6.2% in those who had a negative POC test of cTnT on admission (43). A comparison of POC testing with CLT was performed in 773 consecutive ED patients with acute chest pain for less than 12 h without ST-segment elevation. cTnT and cTnI status (positive or negative) was determined at least twice by POC testing on arrival and 4 h or more later (so that one sample was taken at least 6 h after the onset of pain). Event rates at 30-d of follow-up in patients with negative tests were 1.1% for cTnT and 0.3% for cTnI compared with 22.0% in patients with positive tests (44). There are similar data for the Stratus CS. In 412 ED patients with unstable angina and a cTnI  $\oplus 0.08 \mu\text{g/L}$ , the 30-d event rate was 25.9% compared with 1.5% for those with a cTnI  $< 0.08 \mu\text{g/L}$  (45). In a multicenter evaluation of biochemical diagnostic pathways in 1005 ED patients, a combined strategy using myoglobin plus cTnI was considered the optimal for risk stratification (46).

There is consistent evidence that POC testing can be used for diagnosis of AMI and for risk stratification. There are, however, two limitations. The diagnostic accuracy of these systems has been judged against the World Health Organization (WHO) (47) “conventional” diagnostic criteria rather than those recommended in the American College of Cardiology/European Society of Cardiology (48) troponin-based redefinition of AMI. There have been no published studies comparing a diagnosis by POC testing with diagnosis by CLT using the updated diagnostic criteria. It might be expected that CLT would show a significantly better diagnostic sensitivity under these circumstances, but this will depend on the CLT methodology and cutoff used for the diagnosis of AMI. Similarly, there have been no prospective studies comparing risk stratification by CLT directly with POC testing. Despite these limitations, it is clear that it is possible to use POC testing reliably and safely

as a “rule-in” test. A positive result by POC testing indicates that the patient with a previously uncertain diagnosis has definitely had an AMI and should be admitted to a cardiac area for appropriate further management. A negative test should be followed up by a repeat test, usually later, by CLT. This approach is used successfully as part of the ED workup in a number of US and UK hospitals.

### CLINICAL DECISION MAKING

Because cardiac markers are integral to therapy, it would be expected that POC testing should have a place in therapeutic decision making. The use of a positive test to drive intervention has been studied. A study of CK measurements by POC testing in 117 patients with nondiagnostic ECG showed that management was altered and treatment instituted (in this case thrombolysis) in 15 of 29 (52%) patients solely on the basis of POC testing measurements (49). This finding has not been confirmed for the ED (50). A role could be envisaged for POC testing measurements in stopping low-molecular-weight heparin in cardiac troponin-negative patients or commencing glycoprotein IIb/IIIa antagonists prior to angioplasty and stent placement. Such pathways would be suitable for POC testing but have not been studied as part of a controlled trial. Again, the question will be integration of POC testing within the configuration of the service. Institutions with on-site catheterization facilities and an early aggressive invasive strategy may proceed straight to immediate catheterization in all cases. The justification of such a strategy in the troponin era deserves a critical review. In the majority of cases (even in the United States only 37% of hospitals have cardiac catheterization laboratories and only 25% can perform angioplasty), immediate catheterization either is not available or is a limited resource. The use of rapid cardiac marker measurement prior to decision to treat and transfer would be logical.

The concept of early, rapid exclusion of AMI is the basis of the rapid rule-out protocols used in chest pain evaluation units (51–55). POC testing was studied in a prospective observational study in 1285 consecutive admissions. Initial patient assessment was on clinical grounds plus ECG findings (56). Suspected NSTEMI patients were admitted to CCU for a 6-h multimarker rule-out. Those considered at medium to low risk of unstable angina pectoris or to have nonischemic chest pain had a 90-min rule-out strategy. The diagnostic accuracy in this study was a sensitivity of 100% and a specificity of 94% (although again using WHO criteria for AMI). The event rate in the low-risk group discharged (508 of 1285) was 8 of 508 (1.6%). This study is very useful because it was a “real-time, real-use” study but did not use a control group or a “gold standard” laboratory reference method for comparison, thus providing indicative, rather than definitive, data.

### POC TESTING DECISION LIMITS

The current recommendation is for a very low cutoff for cTnT and cTnI for risk stratification in patients with ACS. These cutoffs are not approached by the currently available POC testing or CLT systems (57). This recommendation is on the basis that there is a continuum of risk according to troponin levels. The question, Does this continuum translate from the highly selected high-probability group of ACS clinical trial populations (58,59) to the general chest pain population (60–62)? has not been completely answered (63). In a study of 4123 ED admissions that divided peak cTnT into four groups—negative (undetectable), low (between the detection limit and the 10% CV limit), intermediate (between the 10% CV and ROC AMI decision limit), and high (above the ROC AMI decision limit)—the event rates in the low, intermediate, and high groups were

statistically different from that of the undetectable group. The event rates between the low and intermediate and between the intermediate and high groups were not statistically different; there was a gray zone between those with an undetectable cTnT and those with a definitely detectable cTnI corresponding to the recommended 10% CV cutoff. Low-level elevations in cTnI have prognostic significance, but this study could not clearly separate on an individual patient basis who was at risk. Whether these findings represented true minor ACS, analytic “false positives,” or non-ACS causes of cTnI elevation (64) cannot be determined but highlight the need for definitive, large-scale, prospective, ideally randomized studies comparing POC testing with CLT to assess whether there is clinical equivalence.

#### **IMPACT OF POC TESTING ON OUTCOME**

The final question is: Does POCT make a difference? The prospective observational ED study of 1285 patients described earlier (56) reported that in 90% of those discharged home, the diagnosis was made at or before the 90-min rule-out test and that utilization of CCU beds decreased compared with historic figures. This study made three changes—the introduction of a critical pathway for chest pain, the switch to POC testing, and the introduction of the 90-min rule-out algorithm—so it is difficult to be certain whether POC testing contributed significantly to the observed effect. The results of previous studies of POC testing in the ED have not been encouraging, with no impact of POC test electrolyte and blood gas measurement on length of stay or patient outcomes (65,66). To date, there has only been one prospective randomized controlled trial comparing POC testing with CLT for cTnT measurements (67). This study again used a new prespecified decision-making pathway using cTnT measurements, and patients were randomized to CLT or POC testing. The study confirmed, as would be expected, the improvement in turnaround time but also reported a statistically significantly improved time to diagnosis of 17.8 h for CLT vs 14.7 h for POC testing in NSTEMI patients. In a prespecified group who met the protocol criteria for early discharge from the CCU (rapid rule-out group), there was a significant reduction in length of hospital stay.

#### ***Markers of Cardiomyocyte Function: BNP***

Measurement of BNP has moved from a well-established but research-based test to a mainstream laboratory investigation. The role of BNP and the N-terminal part of the prohormone (NT-proBNP) has been demonstrated for clinical situations from chronic diagnosis of left ventricular dysfunction (68–70) to risk stratification in ACS (10,71,72). The first commercially available system for rapid BNP measurement was the Biosite Triage method, which has been evaluated for diagnostic utility in acute dyspnea (73,74). POC testing BNP and CLT BNP have been compared and shown to be diagnostically equivalent (75). The clinical utility of BNP measurements has been convincingly demonstrated in a randomized controlled trial of POC testing BNP vs conventional care in 452 patients presenting with acute dyspnea (76). This study showed that the POC testing BNP randomized group had shorter stay and less morbidity. The study did not randomize to a CLT BNP. There are strong observational evidence (77–79) and one small clinical trial (80) that suggest BNP/NT-proBNP measurements can be used to monitor response to therapy. If this is the case, the convenience of having POC testing BNP measurements immediately accessible to adjust medication for cardiac failure in the ambulatory care setting may be important. The use of POC testing for monitoring and guiding therapy is the subject of ongoing investigations.

## CONCLUSION

POC testing for cardiac biomarkers has proven diagnostic accuracy for rule-in and decisions as to whether a patient should be admitted to intensive monitoring. Studies to date suggest that POC testing can be used reliably for ruling out AMI and will reduce hospital stay. The challenges are for the manufacturers to improve analytic performance and for clinicians to conduct well-designed randomized controlled trials that use contemporary diagnostic criteria and are outcome based. POC testing has significantly progressed from the original description of bedside testing in the seventh century by the Byzantine Theophilus Protospatharios and the technical manuals published in the 16th century for clinical workup of a range of medical conditions including chest pain (81). For a start, clinicians no longer have to taste the patient's urine.

## ACKNOWLEDGMENTS

My thanks to David Gaze for his help in preparing Table 1 and to those manufacturers who provided equipment for evaluation.

## REFERENCES

1. Davies MJ. Stability and instability: two faces of coronary atherosclerosis. The Paul Dudley White Lecture 1995. *Circulation* 1996;94(8):2013–2020.
2. Davies MJ, Thomas AC, Knapman PA, Hangartner JR. Intramyocardial platelet aggregation in patients with unstable angina suffering sudden ischemic cardiac death. *Circulation* 1986;73(3):418–427.
3. Falk E. Unstable angina with fatal outcome: dynamic coronary thrombosis leading to infarction and/or sudden death. Autopsy evidence of recurrent mural thrombosis with peripheral embolization culminating in total vascular occlusion. *Circulation* 1985;71(4):699–708.
4. Wu AH, Apple FS, Gibler WB, Jesse RL, Warshaw MM, Valdes R Jr. National Academy of Clinical Biochemistry Standards of Laboratory Practice: recommendations for the use of cardiac markers in coronary artery diseases. *Clin Chem* 1999;45(7):1104–1121.
5. Myocardial infarction redefined—a consensus document of The Joint European Society of Cardiology/American College of Cardiology Committee for the redefinition of myocardial infarction. *Eur Heart J* 2000;21(18):1502–1513.
6. Collinson PO, Boa FG, Gaze DC. Measurement of cardiac troponins. *Ann Clin Biochem* 2001;38(Pt 5):423–449.
7. Antman EM, Anbe DT, Armstrong PW, et al. ACC/AHA guidelines for the management of patients with ST-elevation myocardial infarction—executive summary: a report of the American College of Cardiology/American Heart Association Task Force on Practice Guidelines (Writing Committee to Revise the 1999 Guidelines for the Management of Patients with Acute Myocardial Infarction). *Circulation* 2004;110(5):588–636.
8. Stubbs P, Collinson P, Moseley D, Greenwood T, Noble M. Prognostic significance of admission troponin T concentrations in patients with myocardial infarction. *Circulation* 1996;94(6):1291–1297.
9. Ohman EM, Armstrong PW, Christenson RH, et al. Cardiac troponin T levels for risk stratification in acute myocardial ischemia. GUSTO IIA Investigators [see comments]. *N Engl J Med* 1996;335(18):1333–1341.
10. Richards AM, Nicholls MG, Espiner EA, et al. B-type natriuretic peptides and ejection fraction for prognosis after myocardial infarction. *Circulation* 2003;107(22):2786–2792.
11. Galvani M, Ottani F, Oltrona L, et al. N-terminal pro-brain natriuretic peptide on admission has prognostic value across the whole spectrum of acute coronary syndromes. *Circulation* 2004;110(2):128–134.
12. Mega JL, Morrow DA, de Lemos JA, et al. B-type natriuretic peptide at presentation and prognosis in patients with ST-segment elevation myocardial infarction: an ENTIRE-TIMI-23 substudy. *J Am Coll Cardiol* 2004;44(2):335–339.
13. Collinson PO, Rao AC, Canepa-Anson R, Joseph S. Impact of European Society of Cardiology/American College of Cardiology guidelines on diagnostic classification of patients with suspected acute coronary syndromes. *Ann Clin Biochem* 2003;40(Pt 2):156–160.

14. Bertrand ME, Simoons ML, Fox KA, et al. Management of acute coronary syndromes in patients presenting without persistent ST-segment elevation. *Eur Heart J* 2002;23(23):1809–1840.
15. Collinson PO. The need for a point of care testing: an evidence-based appraisal. *Scand J Clin Lab Invest Suppl* 1999;230:67–73.
16. McCord J, Nowak RM, McCullough PA, et al. Ninety-minute exclusion of acute myocardial infarction by use of quantitative point-of-care testing of myoglobin and troponin I. *Circulation* 2001;104(13):1483–1488.
17. Kilgore ML, Steindel SJ, Smith JA. Evaluating stat testing options in an academic health center: therapeutic turnaround time and staff satisfaction. *Clin Chem* 1998;44(8 Pt 1):1597–1603.
18. Gibler WB, Runyon JP, Levy RC, et al. A rapid diagnostic and treatment center for patients with chest pain in the emergency department [see comments]. *Ann Emerg Med* 1995;25(1):1–8.
19. Gibler WB. Evaluating patients with chest pain in the ED: improving speed, efficiency, and cost-effectiveness, or teaching an old dog new tricks [editorial; comment]. *Ann Emerg Med* 1994;23(2):381, 382.
20. Goodacre SW, Morris FM, Campbell S, Arnold J, Angelini K. A prospective, observational study of a chest pain observation unit in a British hospital. *Emerg Med J* 2002;19(2):117–121.
21. Gomez MA, Anderson JL, Karagounis LA, Muhlestein JB, Mooers FB. An emergency department-based protocol for rapidly ruling out myocardial ischemia reduces hospital time and expense: results of a randomized study (ROMIO). *J Am Coll Cardiol* 1996;28(1):25–33.
22. Goodacre S, Nicholl J, Dixon S, et al. Randomised controlled trial and economic evaluation of a chest pain observation unit compared with routine care. *BMJ* 2004;328(7434):254–260.
23. Collinson PO, Ramhamadamy EM, Stubbs PJ, et al. Rapid enzyme diagnosis of patients with acute chest pain reduces patient stay in the coronary care unit. *Ann Clin Biochem* 1993;30(Pt 1):17–22.
24. Apple FS, Preese LM, Riley L, Gerken KL, Van Lente F. Financial impact of a rapid CK-MB-specific immunoassay on the diagnosis of myocardial infarction. *Arch Pathol Lab Med* 1990;114(10):1017–1020.
25. Wu AH, Clive JM. Impact of CK-MB testing policies on hospital length of stay and laboratory costs for patients with myocardial infarction or chest pain [see comments]. *Clin Chem* 1997;43(2):326–332.
26. Lee-Lewandrowski E, Corboy D, Lewandrowski K, Sinclair J, McDermot S, Benzer TI. Implementation of a point-of-care satellite laboratory in the emergency department of an academic medical center: impact on test turnaround time and patient emergency department length of stay. *Arch Pathol Lab Med* 2003;127(4):456–460.
27. Hirschl MM, Lechleitner P, Friedrich G, et al. Usefulness of a new rapid bedside troponin T assay in patients with chest pain. *Resuscitation* 1996;32(3):193–198.
28. Evaluation of a bedside whole-blood rapid troponin T assay in the emergency department. Rapid Evaluation by Assay of Cardiac Troponin T (REACTT) Investigators Study Group. *Acad Emerg Med* 1997;4(11):1018–1024.
29. Schwartz JG, Gage CL, Farley NJ, Prihoda TJ. Evaluation of the cardiac STATus CK-MB/myoglobin card test to diagnose acute myocardial infarctions in the ED. *Am J Emerg Med* 1997;15(3):303–307.
30. Schouten Y, de Winter RJ, Gorgels JP, Koster RW, Adams R, Sanders GT. Clinical evaluation of the CARDIAC STATus, a rapid immunochromatographic assay for simultaneous detection of elevated concentrations of CK-MB and myoglobin in whole blood. *Clin Chem Lab Med* 1998;36(7):469–473.
31. Brogan GX Jr, Bock JL, McCuskey CF, et al. Evaluation of cardiac STATus CK-MB/myoglobin device for rapidly ruling out acute myocardial infarction. *Clin Lab Med* 1997;17(4):655–668.
32. Panteghini M, Cuccia C, Pagani F, Turla C. Comparison of the diagnostic performance of two rapid bedside biochemical assays in the early detection of acute myocardial infarction. *Clin Cardiol* 1998;21(6):394–398.
33. Luscher MS, Ravkilde J, Thygesen K. Clinical application of two novel rapid bedside tests for the detection of cardiac troponin T and creatine kinase-MB mass/myoglobin in whole blood in acute myocardial infarction. *Cardiology* 1998;89(3):222–228.
34. Sylven C, Lindahl S, Hellkvist K, Nyquist O, Rasmanis G. Excellent reliability of nurse-based bedside diagnosis of acute myocardial infarction by rapid dry-strip creatine kinase MB, myoglobin, and troponin T. *Am Heart J* 1998;135(4):677–683.
35. Muller-Bardorff M, Rauscher T, Kampmann M, et al. Quantitative bedside assay for cardiac troponin T: a complementary method to centralized laboratory testing. *Clin Chem* 1999;45(7):1002–1008.
36. Collinson PO, Jorgensen B, Sylven C, et al. Recalibration of the point-of-care test for CARDIAC T Quantitative with Elecsys Troponin T 3rd generation. *Clin Chim Acta* 2001;307(1-2):197–203.
37. Muller-Bardorff M, Sylven C, Rasmanis G, et al. Evaluation of a point-of-care system for quantitative determination of troponin T and myoglobin. *Clin Chem Lab Med* 2000;38(6):567–574.

38. Apple FS, Christenson RH, Valdes R Jr, et al. Simultaneous rapid measurement of whole blood myoglobin, creatine kinase MB, and cardiac troponin I by the triage cardiac panel for detection of myocardial infarction. *Clin Chem* 1999;45(2):199–205.
39. Altinier S, Mion M, Cappelletti A, Zaninotto M, Plebani M. Rapid measurement of cardiac markers on Stratus CS. *Clin Chem* 2000;46(7):991–993.
40. Heller GV, Blaustein AS, Wei JY. Implications of increased myocardial isoenzyme level in the presence of normal serum creatine kinase activity. *Am J Cardiol* 1983;51(1):24–27.
41. Clyne CA, Medeiros LJ, Marton KI. The prognostic significance of immunoradiometric CK-MB assay (IRMA) diagnosis of myocardial infarction in patients with low total CK and elevated MB isoenzymes. *Am Heart J* 1989;118(5 Pt 1):901–906.
42. Antman EM, Sacks DB, Rifai N, McCabe CH, Cannon CP, Braunwald E. Time to positivity of a rapid bedside assay for cardiac-specific troponin T predicts prognosis in acute coronary syndromes: a Thrombolysis in Myocardial Infarction (TIMI) 11A substudy. *J Am Coll Cardiol* 1998;31(2):326–330.
43. Ohman EM, Armstrong PW, White HD, et al. Risk stratification with a point-of-care cardiac troponin T test in acute myocardial infarction. GUSTOIII Investigators. Global Use of Strategies to Open Occluded Coronary Arteries. *Am J Cardiol* 1999;84(11):1281–1286.
44. Hamm CW, Goldmann BU, Heeschen C, Kreyman G, Berger J, Meinertz T. Emergency room triage of patients with acute chest pain by means of rapid testing for cardiac troponin T or troponin I. *N Engl J Med* 1997;337(23):1648–1653.
45. Heeschen C, Goldmann BU, Langenbrink L, Matschuck G, Hamm CW. Evaluation of a rapid whole blood ELISA for quantification of troponin I in patients with acute chest pain. *Clin Chem* 1999;45(10):1789–1796.
46. Newby LK, Storrow AB, Gibler WB, et al. Bedside multimarker testing for risk stratification in chest pain units: the Chest Pain Evaluation by Creatine Kinase-MB, Myoglobin, and Troponin I (CHECKMATE) study. *Circulation* 2001;103(14):1832–1837.
47. Nomenclature and criteria for diagnosis of ischemic heart disease. Report of the Joint International Society and Federation of Cardiology/World Health Organization task force on standardization of clinical nomenclature. *Circulation* 1979;59(3):607–609.
48. Myocardial infarction redefined—a consensus document of The Joint European Society of Cardiology/American College of Cardiology Committee for the redefinition of myocardial infarction. *Eur Heart J* 2000;21(18):1502–1513.
49. Downie AC, Frost PG, Fielden P, Joshi D, Dancy CM. Bedside measurement of creatine kinase to guide thrombolysis on the coronary care unit. *Lancet* 1993;341(8843):452–454.
50. Gibler WB, Hoekstra JW, Weaver WD, et al. A randomized trial of the effects of early cardiac serum marker availability on reperfusion therapy in patients with acute myocardial infarction: the Serial Markers, Acute Myocardial Infarction and Rapid Treatment Trial (SMARTT). *J Am Coll Cardiol* 2000;36(5):1500–1506.
51. Young GP, Gibler WB, Hedges JR, et al. Serial creatine kinase-MB results are a sensitive indicator of acute myocardial infarction in chest pain patients with nondiagnostic electrocardiograms: the second Emergency Medicine Cardiac Research Group Study. *Acad Emerg Med* 1997;4(9):869–877.
52. Hedges JR, Gibler WB, Young GP, et al. Multicenter study of creatine kinase-MB use: effect on chest pain clinical decision making. *Acad Emerg Med* 1996;3(1):7–15.
53. Hedges JR, Young GP, Henkel GF, Gibler WB, Green TR, Swanson JR. Early CK-MB elevations predict ischemic events in stable chest pain patients. *Acad Emerg Med* 1994;1(1):9–16.
54. Hoekstra JW, Hedges JR, Gibler WB, Rubison RM, Christensen RA. Emergency department CK-MB: a predictor of ischemic complications. National cooperative CK-MB project group. *Acad Emerg Med* 1994;1(1):17–27.
55. Hedges JR, Young GP, Henkel GF, Gibler WB, Green TR, Swanson JR. Serial ECGs are less accurate than serial CK-MB results for emergency department diagnosis of myocardial infarction. *Ann Emerg Med* 1992;21(12):1445–1450.
56. Ng SM, Krishnaswamy P, Morissey R, Clopton P, Fitzgerald R, Maisel AS. Ninety-minute accelerated critical pathway for chest pain evaluation. *Am J Cardiol* 2001;88(6):611–617.
57. Panteghini M, Pagani F, Yeo KT, et al. Evaluation of imprecision for cardiac troponin assays at low-range concentrations. *Clin Chem* 2004;50(2):327–332.
58. Morrow DA, Rifai N, Sabatine MS, et al. Evaluation of the AccuTnI cardiac troponin I assay for risk assessment in acute coronary syndromes. *Clin Chem* 2003;49(8):1396–1398.



59. Cannon CP, Weintraub WS, Demopoulos LA, et al. Comparison of early invasive and conservative strategies in patients with unstable coronary syndromes treated with the glycoprotein IIb/IIIa inhibitor tirofiban. *N Engl J Med* 2001;344(25):1879–1887.
60. Sayre MR, Kaufmann KH, Chen IW, et al. Measurement of cardiac troponin T is an effective method for predicting complications among emergency department patients with chest pain [see comments]. *Ann Emerg Med* 1998;31(5):539–549.
61. Fuchs S, Kornowski R, Mehran R, et al. Cardiac troponin I levels and clinical outcomes in patients with acute coronary syndromes: the potential role of early percutaneous revascularization. *J Am Coll Cardiol* 1999;34(6):1704–1710.
62. Johnson PA, Goldman L, Sacks DB, et al. Cardiac troponin T as a marker for myocardial ischemia in patients seen at the emergency department for acute chest pain. *Am Heart J* 1999;137(6):1137–1144.
63. Kontos MC, Shah R, Fritz LM, et al. Implication of different cardiac troponin I levels for clinical outcomes and prognosis of acute chest pain patients. *J Am Coll Cardiol* 2004;43(6):958–965.
64. Collinson PO, Stubbs PJ. Are troponins confusing? *Heart* 2003;89(11):1285–1287.
65. Kendall J, Reeves B, Clancy M. Point of care testing: randomised controlled trial of clinical outcome. *BMJ* 1998;316(7137):1052–1057.
66. Parvin CA, Lo SF, Deuser SM, Weaver LG, Lewis LM, Scott MG. Impact of point-of-care testing on patients' length of stay in a large emergency department. *Clin Chem* 1996;42(5):711–717.
67. Collinson PO, John CM, Lynch S, et al. A prospective randomised control trial of point of care testing on the coronary care unit. *Ann Clin Biochem* 2004;40:41:397–404.
68. Hobbs FD, Davis RC, Roalfe AK, Hare R, Davies MK, Kenkre JE. Reliability of N-terminal pro-brain natriuretic peptide assay in diagnosis of heart failure: cohort study in representative and high risk community populations. *BMJ* 2002;324(7352):1498–1503.
69. Groenning BA, Raymond I, Hildebrandt PR, Nilsson JC, Baumann M, Pedersen F. Diagnostic and prognostic evaluation of left ventricular systolic heart failure by plasma N-terminal pro-brain natriuretic peptide concentrations in a large sample of the general population. *Heart* 2004;90(3):297–303.
70. Hobbs FD, Davis RC, Roalfe AK, Hare R, Davies MK. Reliability of N-terminal proBNP assay in diagnosis of left ventricular systolic dysfunction within representative and high risk populations. *Heart* 2004; 90(8):866–870.
71. Jernberg T, Stridsberg M, Venge P, Lindahl B. N-terminal pro brain natriuretic peptide on admission for early risk stratification of patients with chest pain and no ST-segment elevation. *J Am Coll Cardiol* 2002; 40(3):437–445.
72. de Lemos JA, Morrow DA, Bentley JH, et al. The prognostic value of B-type natriuretic peptide in patients with acute coronary syndromes. *N Engl J Med* 2001;345(14):1014–1021.
73. Maisel AS, Krishnaswamy P, Nowak RM, et al. Rapid measurement of B-type natriuretic peptide in the emergency diagnosis of heart failure. *N Engl J Med* 2002;347(3):161–167.
74. Cheng V, Kazanagra R, Garcia A, et al. A rapid bedside test for B-type peptide predicts treatment outcomes in patients admitted for decompensated heart failure: a pilot study. *J Am Coll Cardiol* 2001;37(2): 386–391.
75. Wu AH, Packer M, Smith A, et al. Analytical and clinical evaluation of the Bayer ADVIA Centaur automated B-type natriuretic peptide assay in patients with heart failure: a multisite study. *Clin Chem* 2004; 50(5):867–873.
76. Mueller C, Scholer A, Laule-Kilian K, et al. Use of B-type natriuretic peptide in the evaluation and management of acute dyspnea. *N Engl J Med* 2004;350(7):647–654.
77. Anand IS, Fisher LD, Chiang YT, et al. Changes in brain natriuretic peptide and norepinephrine over time and mortality and morbidity in the Valsartan Heart Failure Trial (Val-HeFT). *Circulation* 2003; 107(9):1278–1283.
78. Latini R, Masson S, Anand I, et al. Effects of valsartan on circulating brain natriuretic peptide and norepinephrine in symptomatic chronic heart failure: the Valsartan Heart Failure Trial (Val-HeFT). *Circulation* 2002;106(19):2454–2458.
79. Richards AM, Dougherty R, Nicholls MG, et al. Neurohumoral prediction of benefit from carvedilol in ischemic left ventricular dysfunction. Australia-New Zealand Heart Failure Group. *Circulation* 1999;99(6): 786–792.
80. Troughton RW, Frampton CM, Yandle TG, Espiner EA, Nicholls MG, Richards AM. Treatment of heart failure guided by plasma aminoterminal brain natriuretic peptide (N-BNP) concentrations. *Lancet* 2000; 355(9210):1126–1130.
81. Anon. Seynge of Urynes. R. Kele, London, 1552.

# 33

---

## Proteomics and Discovery of Cardiovascular Biomarkers

---

*Emerson Liu, MD*  
*and Robert E. Gerszten, MD*

### CONTENTS

INTRODUCTION  
TECHNOLOGIES FOR THE DISCOVERY OF BIOMARKERS  
CLINICAL  
CHALLENGES AND PERSPECTIVES  
REFERENCES

---

### SUMMARY

Early disease detection often relies on accurate measurement of serum or plasma biomarkers. Available tests for myocardial infarction, such as immunoassays for the troponins, developed out of studies of those proteins in cardiac physiology. Advancements in protein display and identification technologies now permit characterization of global alterations associated with disease conditions. Plasma proteomics in particular, through an unbiased survey of all proteins associated with a given cardiovascular pathology, may lead to the discovery of novel biomarkers and may provide insight into the cellular mechanisms of disease and uncover new proteins that might serve as targets for therapeutic intervention. Advancing instrumentation and computational methodologies are allowing not only exploration but also quantification of the proteomes of biological tissues and fluids on a wide scale. However, there remains lack of consensus and standardization in technology and techniques. Choice of sample is sometimes not obvious; there is not just one proteome, but many. Faster automation, coupled with more accurate mass determinations, more reliable protein databases to accelerate protein identifications, and greater software support, is needed to realize the true potential of proteomics. Finally, the high sensitivity of mass spectrometry and the present lack of bioinformatics standardization make it critical that any suspected proteomic changes be thoroughly reviewed and verified, with the focus on addressing any inadvertent biases or artifacts of collection, handling, storage, or analysis.

**Key Words:** Proteomics; proteins; prognosis; diagnosis.

From: *Contemporary Cardiology:  
Cardiovascular Biomarkers: Pathophysiology and Disease Management*  
Edited by: David A. Morrow © Humana Press Inc., Totowa, NJ

## INTRODUCTION

The early detection of disease often relies on accurate measurement of serum or plasma biomarkers. Available tests for myocardial infarction (MI), such as immunoassays for the troponins, were developed from studies of those proteins in cardiac physiology. Similarly, basic investigation of many cardiovascular conditions has largely been characterized by studies of isolated molecules in cellular systems. Advancements in protein display and identification technologies now permit one to characterize global alterations associated with disease conditions. In particular, through an unbiased survey of all proteins associated with a given cardiovascular pathology, plasma proteomics may lead to the discovery of novel biomarkers. Just as the current panel of markers has evolved, researchers will be able to ask: Is troponin indeed the best marker of tissue “leakage” following myocardial injury? Are there other proteins released after injury that might serve as better markers or provide complementary information about the extent of infarction? Proteomics is a tool for seeking the answer to these types of questions. Most important, proteomics may provide insight into the cellular mechanisms of disease and uncover new proteins that might serve as targets for therapeutic intervention.

### *What Is Proteomics?*

First introduced in 1995 (1), the term proteome refers to the entire group of proteins associated with a given genome. All cells of a given organism contain an equivalent genomic content. The proteome, however, does not represent all possible proteins that the genome can express. Selective gene expression during development and differentiation, and in response to external stimuli, results in each cell expressing only the fraction of encoded proteins relevant to its functional state at any given time. Thus, one can speak not only of the general human proteome but also more specifically of the proteome of particular cells such as cardiomyocytes, tissues such as the heart, and even of subproteomes that correspond to particular organelles or biological compartments such as the inner mitochondrial membrane.

Conversely, the proteome extends beyond the expression profile of a particular genome. A number of studies suggest that gene expression often correlates poorly with protein levels (2,3). Although protein expression is influenced by the rate of transcription, nucleotide and protein half-lives vary, such that the presence or absence of mRNA may not accurately reflect the presence or absence of the corresponding protein. Additional co- or posttranslational events may affect protein stability. Thus, mRNA sometimes reveals surprisingly little about protein abundance and is also an imperfect predictor of posttranslational regulation.

The proteome associated with a particular gene set includes all variants of the same protein that result as a consequence of differential cellular processing (*see Fig. 1*). Transcription initiation sites may vary for the same protein. Subsequently, as many as one-fourth or more of higher eukaryotic genes can be alternatively spliced, resulting in multiple transcripts. Following transcription, the protein may undergo (often on multiple sites) one or more of greater than 200 potential posttranslational modifications (such as phosphorylation, glycosylation, acetylation, and sulfation). Subsequent additional enzymatic and nonenzymatic alterations culminate in a greatly expanded number of simultaneously existing molecular species. The one gene–one protein dictum, now no longer tenable, had led few to anticipate the immense magnitude and complexity of the resulting proteome.

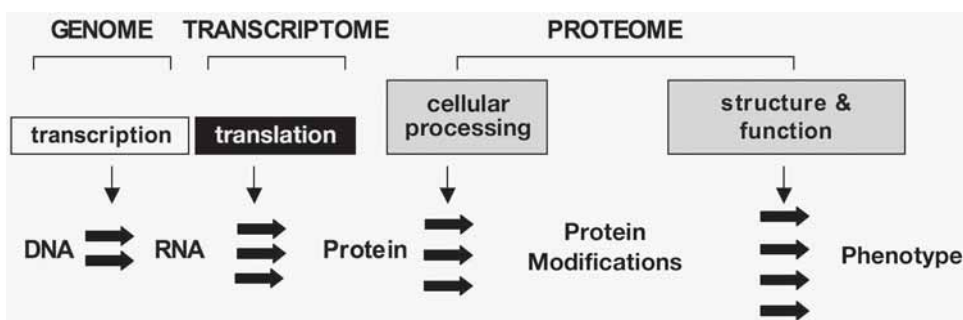


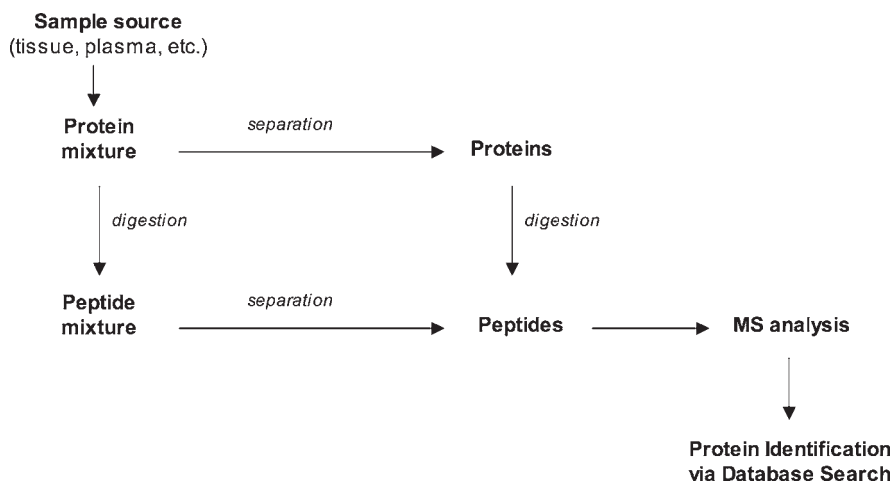
Fig. 1. Relationship between the genome and proteome.

Proteomics uniquely offers insight into disease because proteins and their bioenzymatic functions largely determine the phenotypic diversity that arises from a set of common genes. Posttranslational modifications help regulate structure, function, localization, maturation, and turnover of proteins. Because the entire complement of expressed proteins in their various forms can rapidly change in response to environmental cues, the proteome represents the unique ensemble of proteins that reflects the state of the cell or group of cells at a given time in a particular context under particular stimuli. Thus, the proteome is highly dynamic, in contrast to the stability of the genome. *This complexity is the basis of both its great informative potential and analytic challenge.* Because most pathologies result from protein alterations as either cause or effect, whether by genetic disposition or environmental/pharmacological factors, proteins serve as natural biomarkers and potential therapeutic targets.

## TECHNOLOGIES FOR THE DISCOVERY OF BIOMARKERS

### *Prerequisites for Proteomics Analysis*

A diverse and increasing set of techniques, which share the goal of elucidating the quantitative protein profile of a well-defined system, fall under the rubric of proteomics. Broadly, several features are critical for the success of proteomic technologies. First, the technique must be able to identify a wide breadth of proteins within complex biological samples that contain analytes representative of a broad range of physical characteristics including size and charge. Second, the technology must be sensitive enough to probe the proteome to adequate depths. Often the least abundant proteins play critical regulatory roles in the response to physiological stressors. For example, concentrations of the interleukins, central to many inflammatory and immune responses, fall in the low nanomolar range. Third, tools must also work across a broad dynamic range. That is, they must be able to identify simultaneously both high- and low-abundance proteins in the same complex mixture. This becomes important because satisfactory enrichment techniques for low-abundance proteins remain elusive, with current fractionation methods expanding the dynamic range only by  $10^2$  or so. The ability to analyze unfractionated specimens becomes even more critical with the realization that attempted removal of high-abundance proteins, such as albumin in serum samples, almost always risks removal of the lower-abundance proteins as well. Finally, the ideal technology should be stable and reproducible, an attribute necessary for minimizing artifacts during initial discovery, validation, and testing for clinical applications.



**Fig. 2.** Overview of a proteomics experiment.

An increasingly crucial support for biomarker discovery is the establishment of robust databases that can be searched for validation of identified proteins. The scope of investigation addressable by proteomics has widened immeasurably since the completion of the Human Genome Project. Completion of databases of other model species such as the mouse promises to enhance further the investigational reach. At present, the human databases are by far the largest and easiest to use, which will help accelerate translational investigation. Expressed sequence tags, small DNA sequences generated from the ends of the cDNA of expressed genes, and complete genomic databases collectively provide a catalog of all known or theoretical proteins expressed in organisms for which databases are available. Essential to the interpretation of the data is software that can search through databases for candidate identification. Much of this software has been made available on the Internet.

### *Overview of a Proteomics Experiment*

**Figure 2** summarizes the essential elements of a proteomics approach. Most biological samples consist of a complex mixture containing intact and partially degraded proteins of varying molecular weights, modifications, and solubilities. Proteins are separated in a variety of ways and must eventually be digested to their peptide components in order to obtain sequence information by mass fingerprinting or tandem mass spectrometry (MS/MS), as described below. The sequences are then matched to a protein database to verify the identity of the proteins of interest.

The chances of identifying many peptides in a mixture are increased when the complexity of the mixture is decreased. As suggested by Liebler (4), the problem of complexity and how to deal with it can be likened to the process of printing a book. Whereas printing all the words on a single page could be quickly accomplished, the resulting page would be illegibly black with ink. By dividing the text onto pages, the complexity is reduced to reveal organized text. Samples can be analogously enriched for certain components through fractionation or affinity depletion columns. However, all preparative procedures, including solubilization, denaturation, and reduction processes, should be compatible with the constraints of subsequent analysis steps. More important, the impulse to reduce complexity must be carefully balanced against the fact that each additional step is also an oppor-

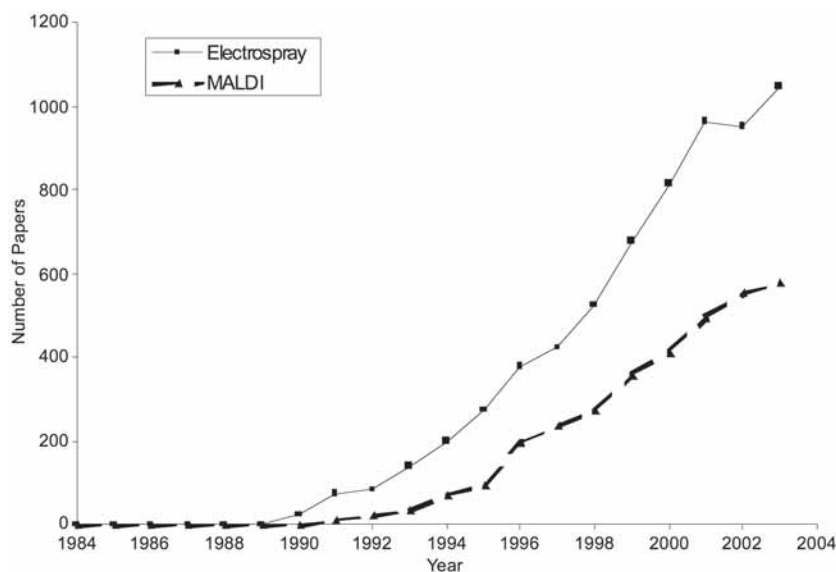


Fig. 3. Rapid incorporation of MS in biomedical research.

tunity to introduce undesired protein modifications or loss. Proteomics techniques are still evolving, with little standardization among investigative groups. Thus, sample preparation is perhaps the most vital parameter of any proteomics study for achieving reproducible results.

### *Two-Dimensional Polyacrylamide Gel Electrophoresis*

The proper choice of proteomics technology, or analytic instrument, is essential. Most proteomics studies to date have relied on two-dimensional polyacrylamide gel electrophoresis (2D-PAGE), which has been an experimental mainstay for the past three decades. With this technique, proteins are extracted and solubilized from biological samples, then separated and resolved in the first dimension based on the isoelectric point and then orthogonally in the second dimension based on relative mass. Comparison of the 2D protein profiles from normal and pathological samples will then reveal disease-related changes in protein expression. Protein spots that vary between conditions are excised from the gel and digested, and the corresponding peptides are identified by MS.

Although significant improvements have been achieved with conventional 2D-PAGE, substantial limitations remain. 2D-PAGE preferentially displays the highly abundant proteins; low sensitivity and restricted dynamic range limit the ability to distinguish low-abundance proteins. Basic proteins and membrane proteins are difficult to detect as well. For plasma samples, 2D-PAGE has a sensitivity in the micromolar range, which enables detection of approx 100–200 proteins, not including modified forms. Several groups suggest that newer modifications of 2D-PAGE technology will substantially improve the number of resolvable proteins. Nevertheless, low throughput and the need for a relatively large amount of sample must be addressed.

### *Mass Spectrometry*

Although 2D-PAGE capabilities continue to advance, the field has increasingly turned to direct mass spectrometric analysis of complex mixtures (Fig. 3), a significant break-

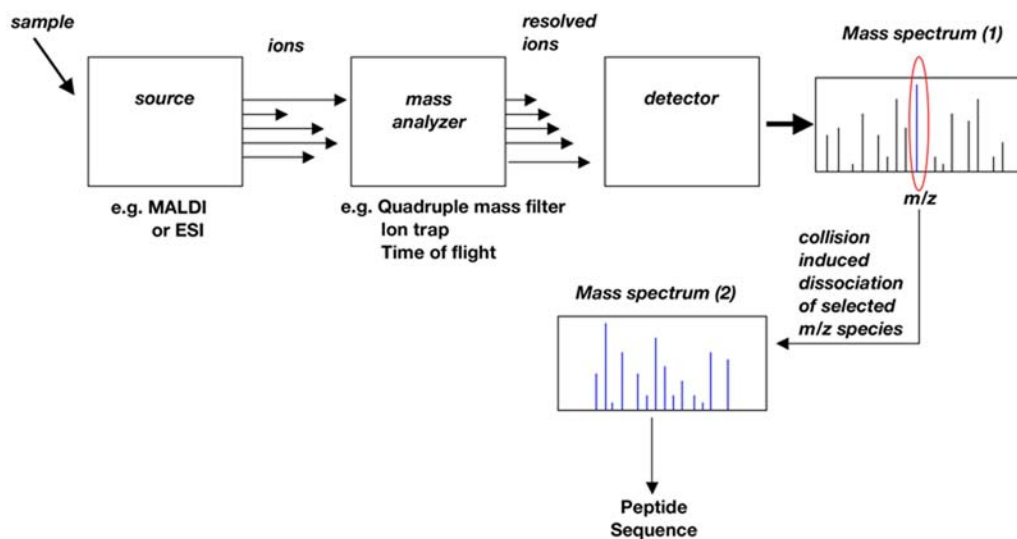


Fig. 4. Schematic of tandem MS.

through that has enabled many of the accomplishments of proteomics analysis. The experimental origins of modern MS date back more than 100 yr, when J. J. Thomson noted that the parabolic trajectory exhibited by ions moving through electric fields was proportional to their “mass-to-charge ( $m/z$ )” values. The first instrument, a parabola spectrograph in 1912, was developed from this observation. Later advances in vacuum technology and electronics led to smaller and more sophisticated instrumentation, with Nobel prizes being awarded to Wolfgang Paul (1999, physics) and John Fenn (2000, chemistry) for their contributions on the quadrupole mass analyzer/ion trap and electrospray ionization (ESI), respectively.

MS instrumentation is unrivaled in its ability to offer several layers of complementary information, having benefited tremendously from whole-genome analysis and the genomics revolution. MS can provide mass measurements of intact proteins far more accurately than can be obtained by gel electrophoresis. MS can also provide accurate mass detection of peptides from proteolytic digests of complex mixtures, with even higher sensitivity and mass accuracy than for detection of whole proteins. The set of peptide mass measurements can be searched against databases, frequently to obtain definitive identification of the parent proteins of interest. Favorably compared against other proteomics technologies, MS is highly sensitive (MS/MS technology, described subsequently, can detect and characterize attomole quantities of peptides) and amenable to automation and thus promotes high-throughput processing. More important, MS has a wide range of applicability and can not only detect proteins but also characterize any posttranslational modifications.

Mass spectrometers are composed of modular elements, which include an ion source, a mass analyzer, and a detector/recorder (*see* Fig. 4). Different types of MS instruments are classified according to the ionization source and mass analyzer employed, but all process samples as gas-phase ions, whose movements within an electromagnetic field can be precisely measured. An ion source generates these gas-phase ions from the analyte through a variety of available techniques, from either the solid state by matrix-assisted laser desorption ionization (MALDI), or directly from the liquid phase by ESI. Modern ESI systems are coupled to antecedent chromatography at low flow rates to fractionate complex peptide

mixtures. Gas-phase ions are subsequently directed into the mass analyzer, which resolves the peptides based on their  $m/z$  ratio. Examples of commonly used mass analyzers include the quadrupole mass filter, ion trap mass analyzer, and time-of-flight (TOF) mass analyzer.

Finally, the detector detects the ions via an electronic multiplier, recording ion intensity vs  $m/z$  value to create the resulting MS spectra. Each protein or set of proteins will yield a unique set of distinct peptides, termed a *peptide mass fingerprint*. The set of peptide masses obtained by MS can be compared to the theoretical mass fingerprints of proteins obtained by *in silico* cleavage of known sequences in searchable databases. However, unambiguous protein identification often requires additional protein sequence information.

In MS/MS, a single  $m/z$  species from the mixture of peptide ions is selected for further analysis. This ion is subjected to collision-induced dissociation, which generates fragment ions from the parent peptide ion. The fragment ions are then analyzed on the basis of their  $m/z$  in a second stage of mass analysis, resulting in a product ion spectrum. The information contained in this tandem MS spectrum permits the amino sequence of the peptide to be deduced. Obtaining an accurate mass or the sequence of a peptide allows one to score its identity against a database of known protein sequences. Most peptide sequences of approximately six or more amino acids in length are uniquely represented in the proteome of an organism and will map to a single gene product. When the sequence corresponds to a common motif, as found in many structural or binding sites, additional information is necessary. A presumed match is corroborated if additional peptide sequences from the same protein are identified.

Again, simplification of the mixture allows data to be collected on the greatest number of components. It is possible to separate the intact proteins first and then cleave them into peptides. It is also possible to cleave the proteins into peptides first and then separate the peptides prior to analysis. As demonstrated in Fig. 4, a combined approach is now generally considered necessary. The peptides are then analyzed as we have outlined, by either TOF instruments, to measure the masses and identify proteins by fingerprinting or, preferably, by ESI-MS/MS, to obtain direct sequence data.

### *Other Technologies*

Over the past decade, the introduction of cDNA or oligonucleotide microarrays has greatly facilitated the ability to measure simultaneously the expression of many or all of the genes in an organism. Analysis of gene expression by microarrays and related methods relies on two processes: polymerase chain reaction (PCR) and hybridization of oligonucleotides to complementary sequences. Unfortunately, there are no analogous methods for use in protein analysis. Whereas an exceedingly small amount of oligonucleotide can be amplified via PCR, a small quantity of polypeptide must be detected and analyzed at native concentrations. Furthermore, there exist no hybridization technologies for binding to complementary amino acid sequences. Although antibodies or oligonucleotide aptamers can recognize specific peptides or proteins, these interactions cannot be predicted solely by knowledge of protein sequence. As noted, the gene code for a protein does not necessarily give rise to only one molecular entity. The presence of multiple posttranslationally modified variant forms increases the analytic challenge beyond the scope of simple transcript profiling. The future realized potential of protein microarrays for profiling and diagnostics will largely depend on the ability to generate expression clones for a whole proteome, including the necessary posttranslational modifications, as well as the development of highly specific antibodies and accurate quantification methods.



At present, limited arrays of antibodies for specific families of proteins do exist. Cytokines, e.g., are an extremely well-studied group of molecules for which multiple antibody reagents are available. Samples such as plasma or urine are incubated on a chip of arrayed antibodies, which are simultaneously screened for multiple analytes. It must be noted, however, that complexing assays onto one chip or slide is a daunting task, because antibodies have different affinities for their ligands, which, in turn, are present across a broad range of concentrations in any given pathological condition. Furthermore, crossreactivity studies must be performed with the addition of each new feature to the existing array. However, this type of “focused proteomics,” by its nature incapable of novel discovery, may ultimately prove valuable in establishing panels of biomarkers that provide useful complementary information to guide diagnosis or therapeutic interventions.

## CLINICAL

### *Considerations for Experimental Design*

Certain features unique to cardiovascular conditions will influence the choice of proper experimental design. Whereas chronic conditions might lead to altered gene expression and changes in protein levels, acute insults will more likely induce rapid posttranslational modifications of preexisting proteins. The need to capture these modifications would also favor the use of certain analysis techniques. Similarly, the short time scale of evolution for acute cardiac conditions and the rapidity of proteome modulation must be considered, and both argue for multiple observations at specific time points.

### *Plasma Proteomics in Cardiovascular Disease*

The plasma proteome is unique in that it does not represent a particular cellular genome but, instead, reflects the collective expression of all cellular genomes. It has thus far been poorly characterized. Twenty-two of the most abundant proteins, including albumin and the immunoglobulins, comprise 99% of the plasma proteome mass. Many of the biologically interesting molecules relevant to cardiovascular disease (CVD) are low-abundance proteins. For example, cardiac markers such as troponin are found in the nanomolar range, insulin in the picomolar range, and tumor necrosis factor- $\alpha$  in the femtomolar range. In all, there are an estimated 10,000 unique proteins in the plasma, with concentrations spanning a dynamic range over 9 orders of magnitude (Fig. 5). However, some hypothesize that the entire set of more than 300,000 estimated human polypeptide species resulting from splice variants and posttranslational modifications is potentially represented in the plasma proteome. This is possible because the protein content of plasma consists not only of expected circulating proteins such as albumin and immunoglobulins (Igs), but also, less expectedly, of proteins from all functional classes and cellular localizations (Fig. 6). A surprising majority of the lower-abundance proteins in plasma actually consists of intracellular or membrane proteins, present as a result of cellular signaling, apoptosis, or necrosis. Efforts to catalog the human plasma proteome using multidimensional separation strategies coupled to MS/MS have led to the identification of more than 1000 unique proteins.

Some investigators have suggested focusing on proteins whose mRNA messages contain motifs suggestive of secreted proteins. As noted, however, analysis of the normal human plasma proteome to date suggests the presence of a vast array of proteins that are not believed to be secreted. Many appear to be surface proteins that may be cleaved in yet unappreciated manners. In any case, because the blood has no single mRNA source, direct analysis of proteins or metabolites is necessary.

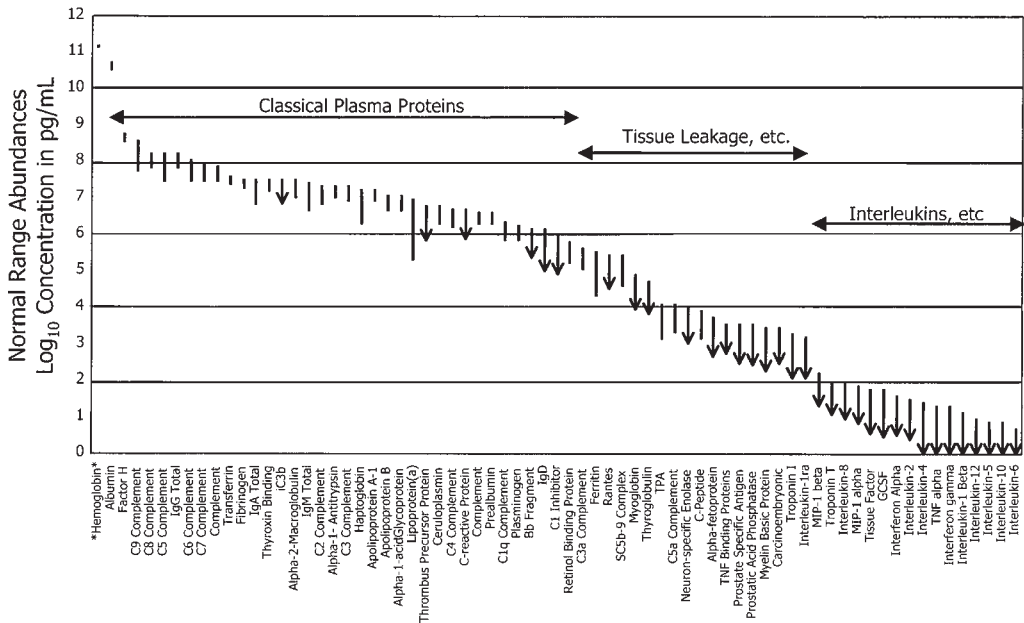
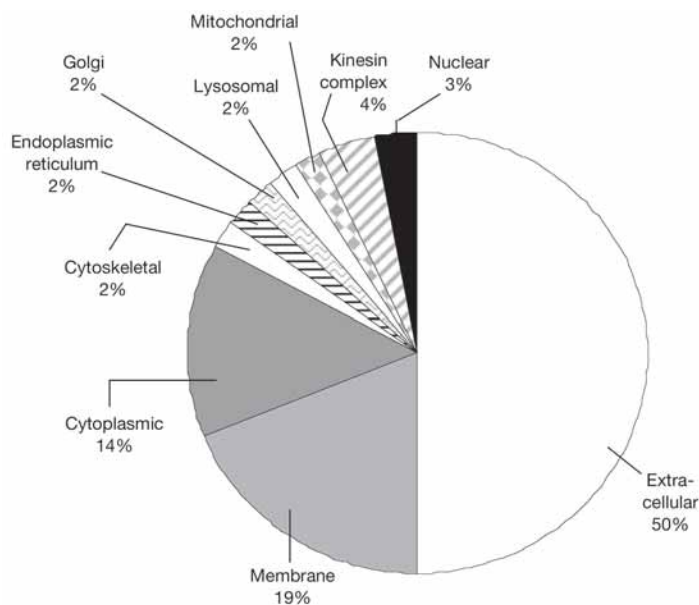


Fig. 5. Complexity of human plasma. (From ref. 5.)

In theory, all diseases lead to perturbations detectable in the blood because almost all cells communicate with plasma, which acts as the common transport conduit of cellular secretions, tissue leakage products, and waste. This makes plasma potentially the most informative proteome from a diagnostic viewpoint. There are also substantial practical advantages to analyzing human plasma for proteomics-based biomarker discovery. Blood represents an easy, inexpensive, and rapidly sampled source for study and may have particular relevance to CVDs in which blood itself is the site of pathology. Blood is also suitable for repeated sampling, both in greater quantity and with less tissue heterogeneity and sampling error compared with biopsy. Because multiple tissues ultimately contribute to the pool of circulating proteins, changes in the plasma proteome can also reflect disease involvement of other organs as well as associated pathophysiology at distant sites. For example, troponin, released from the heart, and C-reactive protein, derived from the liver, arise from different tissues but contribute jointly as complementary markers of cardiac status (7). Other yet-to-be discovered molecules, perhaps those reflecting hemodynamic compromise, might be generated by organs such as the kidneys. Thus, although analysis of specific proteomes, such as of cardiomyocytes or endothelial cells, provides clues on individual components of the disease process, the study of proteomic patterns in the blood offers a more comprehensive framework for biomarker discovery by providing global measurements of all system constituents.

### *Plasma Proteomic Signatures*

Perturbations of the proteome that arise as either a cause or consequence of disease manifest as particular patterns of proteins in the blood. This patterning concept has been the basis for recent efforts to discover proteomic “signatures” in serum. Mass spectrometers can rapidly generate well-defined sets of proteomic peaks from a sample across a broad range of mass/charge. A growing controversy is whether such “protein signatures”



**Fig. 6.** Protein composition of human plasma. (From ref. 6.)

can be used to distinguish accurately disease states from normal. A significant time advantage of direct profile comparisons derives from skipping the far more laborious task of unambiguously identifying the proteins that underlie the peaks. Thus, rapid screening of patient samples is possible. By virtue of their inclusion of multiple proteins, such signatures may have increased diagnostic sensitivity over single protein biomarkers. Most serum profiles to date have been performed in the context of various cancers, including those of the ovary, breast, prostate, and liver. In one highly publicized effort, it was demonstrated that MS coupled with an artificial intelligence algorithm could distinguish ovarian cancer from normal controls with an unprecedented 100% sensitivity and 95% specificity (8).

Using a pattern of peaks to diagnose disease without knowing the represented proteins, however, raises some concerns. One issue is that of reproducibility. Because most mass spectrometers were not designed as clinical tools, it is hard to generate consistent results from machine to machine or from operator to operator. Some contend that the patterns are mostly “noise” and do not discriminate biologically meaningful information. Independent reanalysis of the cancer proteomics data has cast some doubt regarding bias and validity of the data. Without unequivocal protein identifications, one cannot independently confirm findings with complementary technologies such as enzyme-linked immunosorbent assay. Others contend that the peaks profiled by the methodologies used to date only represent the most abundant plasma protein constituents. Such proteins are unlikely to have been released or induced into circulation by very small tumors or their microenvironments. Supporters argue that even when noted peaks are derived from abundant proteins, or represent unusual modifications of abundant proteins such as Ig or albumin, their role as biomarkers is not diminished. The most important consequence of not unequivocally identifying proteins, however, is that little insight is gained into the biology, either to understand disease pathways through basic cellular mechanisms or as a check on the biological consistency and reasonableness of the data. Thus, despite the impressiveness of

the results, explaining the data requires one to invoke novel biological hypotheses. Blinded prospective studies must ultimately be organized to better address the controversy.

Researchers have begun to apply protein profiling to CVD, specifically investigating serum signatures of MI. One team of researchers has attempted to identify patterns in the serum of patients with MI (9). These researchers a diagnostic series of peptide peaks differentially expressed in diseased sera. Ultimately, several peaks were found to relate to complement and fibrinogen products. The researchers acknowledged that the reported patterns were influenced by storage and handling conditions, thus underscoring the importance of sample quality in proteomics studies. Again, prospective validation of such findings in new epidemiological cohorts is critical.

## CHALLENGES AND PERSPECTIVES

Clinical proteomics is currently undergoing a revolution. Advancing instrumentation and computational methodologies are allowing not only exploration but also quantification of the proteomes of biological tissues and fluids on a wide scale. Fueling these advances is the notion that every disease will create characteristic changes that are reflected in the tissue or plasma proteome. This is a systems biology approach, in which all concurrent processes of a cell or tissue can be monitored in defined physiological states. The remarkable degree of information made accessible by proteomics also moves the field closer to more individualized forms of medicine, in which one becomes aware of not only disease perturbations, but also the even greater normal biological variations within and between healthy individuals.

Despite the great need for additional biomarkers, The Food and Drug Administration has only approved about one new diagnostic per year over the past decade. Proteomics profiles promise to transform clinical diagnostics, especially for the majority of conditions that are multifactorial in nature and unlikely to have single, specific markers. However, the field is still in its infancy. There is lack of consensus and standardization in technology and techniques. Several fundamental issues remain unresolved regarding the best way to collect and store samples, in part because one cannot anticipate all future needs from samples stored presently. Which sample to choose is sometimes not obvious, because there are many proteomes, not just one. One can therefore choose to look at any subproteome in any biological tissue, focusing on proteins or posttranslational modifications. Bioinformatics is perhaps the biggest bottleneck currently. Identification of proteins continues to be a slow process. Data from one experiment may take several weeks to months or years to analyze fully. Faster automation as well as more accurate mass determinations, more reliable protein databases to accelerate protein identifications, and greater software support is needed to realize the true potential of proteomics. Finally, the facts that MS is highly sensitive and there is currently a lack of bioinformatics standardization make it critical that any suspected proteomic changes be thoroughly reviewed and verified, while addressing any inadvertent biases or artifacts of collection, handling, storage, or analysis.

In searching for novel biomarkers, one begins with broad-based screening because often little is known about the pathways involved. Whether these findings translate into clinical utility will ultimately depend on the ability to develop high-throughput assays. The overarching goal, however, is to relate findings back to biology to characterize the molecular mechanisms of disease. Proteins, their functionally relevant modifications, and binding partners must all be placed in cellular pathways in order to generate new hypotheses leading to future therapeutics. The scope of expertise relevant to such endeavors will

necessarily involve increasing collaborative efforts among clinical investigators, laboratory scientists, and bioinformatics specialists.

## REFERENCES

1. Wasinger VC, Cordwell SJ, Cerpa-Polijak A, et al. Progress with gene-product mapping of the Mollicutes: *Mycoplasma genitalium*. *Electrophoresis* 1995;16(7):1090–1094.
2. Anderson L, Seilhamer J. A comparison of selected mRNA and protein abundances in human liver. *Electrophoresis* 1997;18(3–4):533–537.
3. Gygi SP, Rochon Y, Franza BR, Aebersold R. Correlation between protein and mRNA abundance in yeast. *Mol Cell Biol* 1999;19(3):1720–1730.
4. Liebler DC. *Introduction to Proteomics*. 2001; Humana, Totowa, NJ.
5. Anderson NL, Anderson NG. The human plasma proteome: history, character, and diagnostic prospects. *Mol Cell Proteomics* 2002;1(11):845–867.
6. Anderson NL, Polanski M, Pieper R, et al. The human plasma proteome: a nonredundant list developed by combination of four separate sources. *Mol Cell Proteomics* 2004;3(4):311–326.
7. Sabatine MS, Morrow DA, de Lemos JA, et al. Multimarker approach to risk stratification in non-ST elevation acute coronary syndromes: simultaneous assessment of troponin I, C-reactive protein, and B-type natriuretic peptide. *Circulation* 2002;105(15):1760–1763.
8. Petricoin EF, Ardekani AM, Hitt BA, et al. Use of proteomic patterns in serum to identify ovarian cancer. *Lancet* 2002;359(9306):572–577.
9. Marshall J, Kupchak P, Zhu W, et al. Processing of serum proteins underlies the mass spectral fingerprinting of myocardial infarction. *J Proteome Res* 2003;2(4):361–372.

# 34

---

## Genetic Markers in Cardiovascular Disease

---

*Marc S. Sabatine, MD, MPH*

### CONTENTS

SIMPLE VS COMPLEX GENETIC DISEASES  
ESTABLISHING GENETIC DETERMINANTS OF COMPLEX DISEASES  
CANDIDATE GENES  
LARGE MULTILOCUS STUDIES  
GENOME-WIDE SCANS  
CONCLUSION  
REFERENCES

---

### SUMMARY

For classic “Mendelian” genetic diseases, a single gene is responsible. A rare mutation in that gene causes a dramatic change in protein concentration or function that is both necessary and sufficient to cause the disease, and environmental factors play a small or nonexistent role. Examples in cardiology include familial hypercholesterolemia, familial hypertrophic cardiomyopathy, Marfan syndrome, and congenital long QT syndrome. By contrast, for complex genetic diseases, multiple genes are involved and environmental factors play a large role. Variants in any single gene therefore tend to be associated with far more modest effects and are neither necessary nor sufficient to cause the disease. The genetic variants responsible for these modest effects tend to be more common (>1% prevalence) and, by convention, are called polymorphisms, rather than mutations. Most of the common diseases in cardiology fall into this category, including hypertension, atrial fibrillation, and coronary heart disease (CHD). Currently, no genetic markers are ready for widespread adoption as risk factors for CHD. Yet, there are several promising, biologically plausible candidates. Researchers are now designing larger and better studies in order to maximize the chances of detecting subtle but likely important contributors to CHD.

**Key Words:** Genetics; genome; prognosis; diagnosis.

### SIMPLE VS COMPLEX GENETIC DISEASES

One hundred forty years ago, Gregor Mendel, an Austrian monk, presented his observations on the inheritance in the garden pea plant of certain traits, including seed color and texture (1). Mendel described three properties of heritable factors: that there was a

From: *Contemporary Cardiology:  
Cardiovascular Biomarkers: Pathophysiology and Disease Management*  
Edited by: David A. Morrow © Humana Press Inc., Totowa, NJ

Table 1  
Simple (Mendelian) vs Complex Human Diseases

	<i>Simple</i>	<i>Complex</i>
Examples	Familial hypercholesterolemia, hypertrophic cardiomyopathy, Marfan syndrome, congenital long QT syndrome	Hypertension, CHD, atrial fibrillation
Frequency	Rare	Common
Number of genes involved	Single	Multiple
Effect of mutation on protein	Severe	Mild
Effect of mutation on phenotype	Large	Small
Relative importance of environmental factors	Small	Large

unit of inheritance that produced an observable trait (now known as a gene), that heritable factors for a given trait segregated independently (Mendel's First Law), and that for two different traits the heritable factors assorted independently (Mendel's Second Law).

However, Mendel's laws ran counter to the prevailing school of thought at that time, which postulated a blending of parental characteristics in offspring. Galton and Pearson had convincingly observed that several anthropometric traits appeared to follow the blending theory. A clear example was height, for which children's phenotype tended to be midway between their two parents, rather than replicating one parent or the other. This controversy was resolved in 1918 when Ronald Fisher delineated the notion of polygenic inheritance (2).

For classic "Mendelian" genetic diseases, a single gene is responsible. In that gene a rare mutation causes a dramatic change in protein concentration or function that is both necessary and sufficient to cause the disease. The role that environmental factors play is small or nonexistent. Examples of Mendelian genetics include Mendel's garden pea seed color and texture and the human diseases of sickle cell anemia, cystic fibrosis, and Huntington disease. Examples in cardiology include familial hypercholesterolemia, familial hypertrophic cardiomyopathy, Marfan syndrome, and congenital long QT syndrome.

By contrast, multiple genes are involved in complex genetic diseases, and environmental factors play a large role (Table 1). Variants in any single gene therefore tend to be associated with much more modest effects and are not necessary or sufficient to cause the disease. The genetic variants responsible for these effects are usually more common (>1% prevalence) and are called polymorphisms, rather than mutations. Gene–gene interactions (epistasis) and gene–environment interactions can be significant. Most of the common diseases in cardiology fall into the category of complex genetic disorders, including hypertension, atrial fibrillation, and what is the focus of this chapter: coronary heart disease (CHD).

Although diseases are thought of as discrete outcomes, to understand complex genetic disorders, it may be easier to conceptualize the genetic effect as influencing an intermediate quantitative trait with a Gaussian distribution. The presence of the variant allele causes a shift in the distribution of the trait. Other genes and environmental factors may also influ-

ence the trait. Disease occurs when the trait exceeds a certain threshold. In the case of a simple Mendelian disorder such as sickle cell anemia, a substitution of valine for glutamic acid as the sixth amino acid in the  $\beta$ -globin chain in hemoglobin causes a very large shift in the solubility of deoxygenated hemoglobin. Leaving aside the other rare Mendelian hemoglobinopathies, other genetic and environmental effects are sufficiently minor so that individuals who are homozygous for the mutation have the disease sickle cell anemia, and those who are not do not have the disease.

By contrast, for a complex disorder such as myocardial infarction (MI), a polymorphism in a gene encoding a receptor that is located on the surface of a platelet may cause a subtle shift in platelet aggregability. This shift increases the risk of MI but alone is not sufficient to cause an MI, and the majority of individuals with this polymorphism will never develop an MI. However, when a nongenetic risk factor is superimposed, such as coronary artery atherosclerotic plaque rupture, in an individual with the prothrombotic polymorphism the disease threshold may be crossed, and the individual may develop an occlusive coronary thrombus and have an acute MI (AMI), whereas in a wild-type individual the ruptured site may simply heal over.

## ESTABLISHING GENETIC DETERMINANTS OF COMPLEX DISEASES

Before attempting to define the specific genetic components of a human disease, one must first establish that there is evidence for a genetic contribution. For MI, several studies have demonstrated higher rates of MI among relatives of patients who died from MI than among relatives of healthy control subjects (3–7). Subsequent twin and adoption studies have confirmed a significant genetic component to coronary artery disease (CAD) and vascular death, with the risk of death from CAD eightfold higher if a monozygotic twin died of CAD (8,9). Thus, there is compelling evidence that there can be a genetic component to CHD, and to that end a family history of CHD is an established risk factor for MI.

### *Linkage Analysis*

For Mendelian disorders, family studies using linkage analysis of random genetic markers has been the typical approach. Linkage analysis relies on the cosegregation of known polymorphic DNA markers with nearby but unknown disease-causing alleles in families. The use of restriction fragment length polymorphisms (RFLPs), polymorphic microsatellite loci, and single-nucleotide polymorphisms (SNPs) has allowed fine mapping and positional cloning. However, linkage analysis has not proven successful in complex disorders owing to a high false-positive rate (10). By contrast, population association studies using a candidate gene approach investigate the nonindependence of putative disease-causing genotype and the disease phenotype in a collection of nonrelated individuals. This approach has been the most common one to complex genetic disorders (11). As high-throughput genetics has become possible, larger and larger numbers of candidate genes can be assessed simultaneously (12). Haplotypes are specific combinations of adjacent SNPs. They potentially offer greater precision if the SNPs being tested may not be causal, but in tight linkage disequilibrium with nearby but unknown disease-causing variants. In those cases, recombination between the marker SNP and the disease-causing variant will erode the association in some patients and lead to confusing results. The presence of two SNPs, potentially flanking the disease-causing variant, increases the likelihood of maintaining linkage with the disease-causing variant. In addition, haplotype tagging can be used to reduce geno-



**Table 2**  
**Limitations to Genetic Association Studies**

---

<i>Genotype</i>
Genetic heterogeneity: when the same phenotype is caused by polymorphisms in different genes
Allelic heterogeneity: when the same phenotype is caused by different alleles of the same gene
Genotyping error: misassignment of genotype
Epistasis: when the effect of a genotype depends on the presence of another genotype
Gene–environment interactions: when the effect of a genotype depends on the presence of an environmental factor
<i>Phenotype</i>
Phenotypic heterogeneity: nonhomogeneous cases
Phenocopy: environmentally caused phenotype that mimics the genetically caused phenotype
<i>Statistical issues</i>
Confounding: a type of bias in which an artifactual association between a predictor and an outcome is caused by a third factor independently associated with both the predictor and the outcome
Population stratification: a nonethnically homogeneous study population in which one ethnic group is overrepresented in cases and also happens to have a higher prevalence of certain non-disease-causing genetic variants
Small sample size: a design flaw that predisposes to false-negative studies (type II error)
Multiple testing: analyses that, without proper adjustment, predispose to false positive studies (type I error)
Publication bias: the observation that positive studies are more likely to be published than negative studies

---

typing efforts and focus on the few key SNPs that define haplotype blocks (13). Researchers have also employed high-density genomewide scans using random markers and relying on linkage disequilibrium (14).

### *Association Studies*

Genetic association studies have their own limitations, of which it is vital to be cognizant (Table 2). Genetic heterogeneity occurs when different genotypes can lead to the same phenotype. Allelic heterogeneity occurs when different alleles of the same gene lead to the same phenotype. Genotyping error, estimated to occur at a rate of 1–3% (15), adds noise to the signal. In general, it biases toward the null, although genotyping errors that happen to move cases in or out of small groups (typically homozygotes for the rare allele) can also lead to false positive associations. Gene–gene (epistasis) and gene–environment interactions can further complicate the picture, making associations apparent in one population and not in another. Phenotypic heterogeneity refers to variability in case or outcome definitions. For example, the genetic determinants of atherosclerosis and AMI may be very different. In general, the more restrictive and specific the case definition, the easier it will be to detect an underlying genetic contribution. Phenocopy is related and refers to an environmentally caused phenotype that mimics the genetically caused phenotype. For example, both a 45-yr-old man and a 75-yr-old man can have an MI. In the former individual, genetic factors may have played a critical role, whereas in the latter, environmental factors such as long-standing hypertension, hyperlipidemia, and diabetes may have been the driving factors.

Confounding is a concern in any association study. To be cost-effective, most of these studies employ a case–control design. As with any case–control study, a critical factor is the selection of suitable control subjects so as to minimize confounding. This problem is minimized when a cohort design is used or when a case–control study is nested within a prospective cohort. Population stratification is a special type of confounding in genetic studies that can occur whenever a nonethnically homogeneous population is studied (16, 17). For example, MI may be more prevalent in an ethnic group owing to a variety of genetic and environmental factors (e.g., poor diet, obesity, limited access to medical care and primary prevention therapies). Any polymorphism that occurs more frequently in that ethnic group, even if it is unlinked to disease-causing loci, will spuriously appear to be associated with MI. Genomic control is a technique to control for potential population stratification, in which a series of random markers is genotyped in addition to the candidate loci (18–20).  $\chi^2$  test statistics for independence for the null loci are computed and, based on their variability and magnitude, a multiplier ( $\lambda$ ) is derived to adjust the critical value for significance tests for the candidate loci.

Small sample size is a frequent limitation in genetic association studies. The excess risk or benefit associated with a polymorphism is likely to be modest in magnitude. It would require close to 3000 case–control pairs to have 80% power at the two-sided 5% significance level to detect a minor allele that had a frequency of 0.10 and in a dominant model was associated with a 20% increase in the risk of a given outcome. The converse is an even greater problem. Multiple testing can lead to false-positive associations and is one of the major limitations to association studies. With 30,000 genes and an estimated 10 million SNPs, the number of possible association tests is enormous. Strict Bonferroni correction can lead to an overly cautious approach that misses true associations (21). Other techniques have been developed to control experimentwise error rates including setting the false discovery rate and doing permutation testing (22,23). Lander and Kruglyak (24), as well as others, have proposed replication by other studies as a requirement before proclaiming a confirmed association. In a recent article published in *Nature Genetics*, Lohmueller et al. (25) reported on a meta-analysis that they conducted of 301 published studies for 25 different reported significant genetic associations. Less than half of these associations were replicated on meta-analysis. These investigators found that two studies with  $p < 0.01$  or a single study with  $p < 0.001$  was strongly predictive of future replication. Publication bias can limit the utility of meta-analyses because positive studies tend to be published whereas negative studies are not (26). Funnel plots, which are plots of the estimates of effect size in each study against the sample size in that study, may be useful to assess the validity of meta-analyses (27,28). In an analysis of meta-analyses of genetic association studies, Ioannidis et al. (29) found that in only 16% of meta-analyses was the genetic association significant and replicated without evidence of heterogeneity or bias. In general, larger studies yielded more conservative genetic effect estimates than did smaller studies.

Finally, it is important to remember that statistical association is not proof of causality. A polymorphism associated with a disease may not be the causal variant but, rather, be in strong linkage disequilibrium with the true causal variant within the same gene or even potentially in nearby genes. This can lead to inconsistencies among studies if the true causal variant arose in different genetic backgrounds in different populations. Molecular biology studies are usually required to unravel the true underlying pathophysiology.

Lusis (30) recently estimated that hundreds of genes are involved with cardiovascular disease (CVD) (Fig. 1). At the same time, genotyping has become easier to do and, hence,

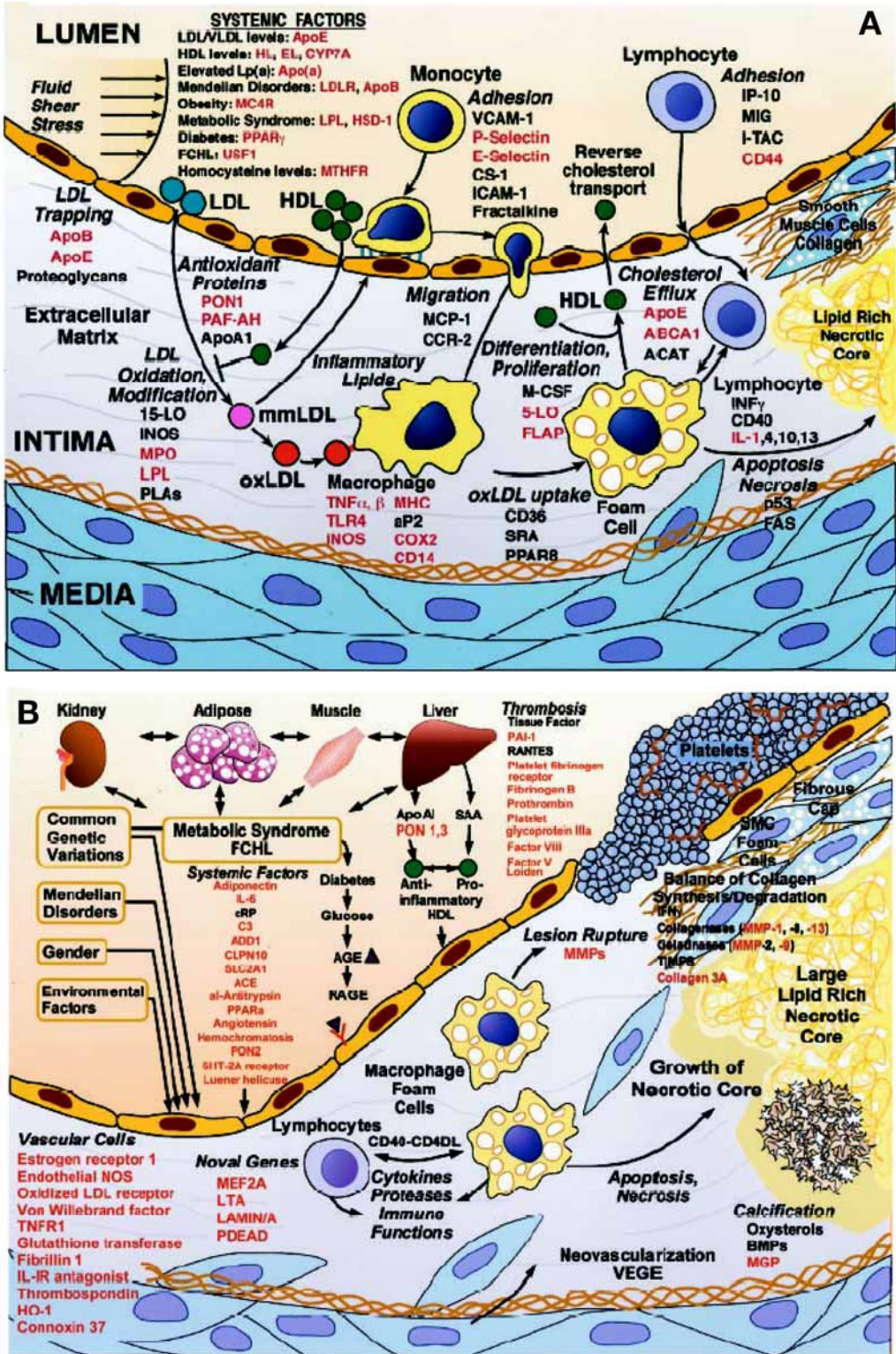


Fig. 1. Candidate genes for genetic susceptibility to CHD during (A) lesion formation and (B) plaque rupture. (From ref. 133, with permission.)

the number of publications on genetic polymorphisms has risen exponentially (31). In 2004 alone there were 6700 publications. Cataloguing all the genetic studies of all the forms of CVD is well beyond the scope of this chapter. Instead, I focus on CHD and review seminal genetic association studies that illustrate the limited successes achieved to date and the many hurdles that researchers still face.

## CANDIDATE GENES

### *Glycoprotein IIIa*

#### ASSOCIATION WITH CHD

One of the first genetic variants to receive widespread attention as a putative prothrombotic polymorphism was the  $PI^{A2}$  allele of the glycoprotein (Gp) IIIa receptor. This protein is a key subunit in the GpIIb/IIIa receptor, which is found on the surface of platelets, binds fibrinogen, and mediates platelet aggregation. In a case–control study published in 1996 involving 71 patients admitted with an acute coronary syndrome (ACS) and 68 inpatient control subjects without known heart disease, carriage of the  $PI^{A2}$  allele was associated with an increased risk of ACS (odds ratio [OR]: 2.8; 95% confidence interval [CI]: 1.3–5.9) (32). This effect was even more pronounced in those <60 yr of age (OR: 6.2; 95% CI: 2.0–19.0). Two months later, the same investigators took personalized medicine a step further, revealing that, in collaboration with physicians at Lake Placid, they had thawed a stored blood sample from figure-skating gold medalist Sergei Grinkov, who, at age 28, had died suddenly of an MI while training (33). Genotyping revealed that Grinkov carried the  $PI^{A2}$  allele. Additional small studies seemed to support the association between the  $PI^{A2}$  allele and premature MI, stent thrombosis, and restenosis (34–36). In addition, several in vitro studies suggested that the  $PI^{A2}$ -positive platelets were more easily activated and more readily aggregated (37,38).

Despite these encouraging initial observations, subsequent case–control studies nested in large cohorts failed to show any association between the  $PI^{A2}$  allele and MI (39,40). In addition, a large study involving 1000 case–control pairs failed to show any association between the  $PI^{A2}$  allele and adverse cardiovascular events after percutaneous coronary intervention (PCI) (41). Two subsequent meta-analyses combined data from up to 34 studies (almost all of them case–control) involving 17,000 individuals (42,43). The analyses did not include the same studies and employed slightly different methodologies. Nonetheless, the results were similar in that in both meta-analyses carriage of the  $PI^{A2}$  allele was associated with at most a modest risk of CAD (OR: 1.06; 95% CI: 0.97–1.16; and OR: 1.10; 95% CI: 1.03–1.18). In both analyses, the risk was numerically, if not statistically, greater in those <60 yr of age and in women. A subsequent cohort study involving more than 9000 individuals participating in the Copenhagen City Heart Study did not provide evidence for an association between  $PI^{A2}$  heterozygotes and MI (adjusted OR: 1.0) (44). However, the investigators highlight that the subgroup of male  $PI^{A2}$  homozygotes <40 yr of age ( $n = 37$ ) had an increased risk of MI compared with  $PI^{A1}$  homozygotes (adjusted OR: 3.8; 95% CI: 1.0–15).

This saga illustrates several important and related points. As noted earlier, the true effect of prothrombotic polymorphisms is likely to be small, on the order of only a 10–20% increase in risk. The small size, however, of many genetic association studies means that only large effects will reach nominal statistical significance. Unfortunately, positive studies with statistically significant associations are more likely to be published than negative ones. This is illustrated in both of the aforementioned meta-analyses, in which weighted

funnel plots showed clear asymmetry, with smaller studies reporting larger ORs than larger studies. This often translates into what has been dubbed the “winner’s curse,” in which the first exploratory study to report an association claims a magnitude of effect that is ultimately found to be far less robust in larger follow-up studies.

### PHARMACOGENOMIC OBSERVATIONS

Of special interest in the case of the GpIIb/IIIa receptor is the fact that the receptor has also been the focus of pharmacological intervention. Therefore, the study of pharmacogenomic interactions is very promising. GpIIb/IIIa inhibitors block platelet aggregation and, hence, are potentially useful antiplatelet medications in ACSs. The Orbofiban in Patients with Unstable Coronary Syndromes (OPUS)-TIMI 16 trial was a phase 3 clinical trial evaluating the oral GpIIb/IIIa inhibitor orbofiban in 10,288 patients with a recent ACS (45). Genetic analyses were done in a subset of 1014 patients (46). In those patients who were at high risk of recurrent cardiac ischemic events, there was a trend toward a higher rate of death, MI, recurrent ischemia, or stroke in patients with the  $PI^{A2}$  allele (relative risk [RR]: 1.26; 95% CI: 0.91–1.76) and a dose–response effect (event rate of 15.4% in  $PI^{A1/A1}$  patients, 18.4% in  $PI^{A1/A2}$  patients, and 22.7% in  $PI^{A2/A2}$  patients). In particular, the rate of MI was significantly higher among  $PI^{A2}$  allele carriers (RR: 2.71; 95% CI: 1.37–5.38).

In the overall trial cohort, orbofiban did not affect the rate of the primary end point. However, on stratification by genotype, a more complex picture emerged. Treatment with orbofiban was associated with an RR of the composite end point of 0.73 (95% CI: 0.51–1.06) among  $PI^{A2}$  allele noncarriers, whereas it was associated with an RR of 1.37 (95% CI: 0.75–2.51) among  $PI^{A2}$  allele carriers. These differences were even more striking for MI, for which the RRs with orbofiban were 0.59 (95% CI: 0.23–1.53) and 2.46 (95% CI: 0.70–8.67), respectively, among  $PI^{A2}$  allele noncarriers and carriers ( $P_{\text{interaction}} = 0.08$ ). Similar patterns were seen for bleeding, in which the RRs were 1.87 (95% CI: 1.29–2.71) among  $PI^{A2}$  allele noncarriers and 0.87 (95% CI: 0.46–1.64) among  $PI^{A2}$  allele carriers ( $P_{\text{interaction}} = 0.05$ ).

It is proposed that these findings may be explained by orbofiban acting as a partial agonist for the GpIIb/IIIa receptor on  $PI^{A2}$ -positive platelets. Platelet function studies with orbofiban suggest that the drug can induce  $\alpha$ -granule degranulation, P-selectin expression, conformational changes in the GpIIb/IIIa receptor, and fibrinogen binding (47,48). The results of the OPUS-TIMI 16 genetic substudy raise the possibility that orbofiban acts as an *antagonist* in  $PI^{A2}$  allele noncarriers (reduction in thrombotic events and increase in bleeding) but as a *partial agonist* in  $PI^{A2}$  allele carriers (increase in thrombotic events, no effect on bleeding).

### *Angiotensin-Converting Enzyme*

Another gene that has undergone intense investigation is the angiotensin-converting enzyme (ACE) gene. A common variant consisting of a 287-bp Alu insertion element in intron 16 was reported in 1990 (49). Alu elements are the most common example of short interspersed elements, which represent reverse transcripts of RNA sequences that have become embedded in the genome (50). Of note, this variant is associated with differences in serum ACE levels and accounts for nearly half the interindividual variance of ACE levels, with the deletion allele associated with higher circulating levels. Although the insertion/deletion (I/D) polymorphism itself is not believed to be functional, it appears to be in tight linkage disequilibrium with a variant that is (51). Two years after the initial report of this polymorphism, investigators from Etude Cas-Temoin de l’Infarctus du Myo-

carde reported the results of a nested case–control study in which homozygosity for the deletion allele was associated with a substantially increased risk of MI (OR: 1.34; 95% CI: 1.05–1.70) (52). More than a dozen studies followed, and 4 yr later a meta-analysis involving 3394 cases and 5479 controls appeared to confirm the association between the DD genotype of the ACE I/D variant and the risk of MI, with an OR of 1.26 (95% CI: 1.15–1.39) (53).

However, most of the studies contributing to this meta-analysis were small. A large-scale case–control study using nearly 5000 cases from the ISIS-3 trial and nearly 6000 controls revealed a much smaller risk for MI with the DD genotype (RR: 1.10; 95% CI: 1.00–1.21) (54). Performing meta-analyses stratified by study size, Keavney et al. (54) found that among 35 small studies (<200 cases each) the combined RR was 1.57 (95% CI: 1.38–1.78), whereas among 14 larger studies (≥200 cases each) the combined RR was 0.99 (95% CI: 0.90–1.08). This stratification illustrates how the validity of a meta-analysis depends on the quality of the individual studies that are combined. Given the small effect sizes anticipated and the effect of publication bias, definitive evidence for genetic association usually requires large-scale trials.

The relationship between the ACE I/D polymorphism and several other cardiovascular outcomes has also been examined. More than a dozen studies have examined whether this polymorphism is associated with restenosis after PCI. One meta-analysis calculated the combined OR to be 1.22 (95% CI: 1.04–1.44) (55). However, there appeared to be evidence of publication bias. A second meta-analysis illustrated this when combined ORs were stratified by trial size. In trials that involved fewer than 100 cases, the combined OR was 1.94 (95% CI: 1.39–2.71), in those with 100–200 cases it was 1.33 (95% CI: 0.92–1.93), and in those with more than 200 cases it was 0.92 (95% CI: 0.72–1.18) (56). Thus, as with MI, it is doubtful that the ACE I/D polymorphism plays a major role in restenosis. *A priori* the most logical end point to examine for an ACE gene variant is hypertension. Multiple, small case–control studies yielded conflicting results and a sib-pair linkage study was negative (57). In a large cohort derived from the Framingham Heart Study, there did appear to be an association between the DD genotype and hypertension in men (adjusted OR: 1.59; 95% CI: 1.13–2.23), but not in women (adjusted OR: 1.00; 95% CI: 0.70–1.44) (58). Further study, including appropriately powered exploration of pharmacogenomic interactions between this polymorphism and the utility of ACE inhibitors, is needed.

### ***Methylenetetrahydrofolate Reductase***

Hyperhomocysteinemia has been associated with an increased risk of CAD (59,60). Methylenetetrahydrofolate reductase (MTHFR) is an enzyme that catalyzes the metabolism of homocysteine via remethylation to methionine. In 1988, Kang et al. (61) described a thermolabile variant of MTHFR that was associated with decreased enzymatic activity and higher circulating concentrations of homocysteine. Several years later, Frosst et al. (62) identified the genetic basis for this variant: a 677 C/T or Ala222Val polymorphism in *MTHFR*. Two case–control studies, one from Ireland and one from the Netherlands, suggested that individuals homozygous for the variant allele were at a significantly increased risk of CAD (63,64). However, multiple other studies based in North America failed to find any association between *MTHFR* genotype and CAD (65–70). A meta-analysis of 40 studies, incorporating 11,162 cases and 12,758 controls, looked for evidence of significant publication bias but found none (71). Rather, a more biologically complex pattern was revealed. Overall, individuals homozygous for the TT genotype had a modest

but statistically significant increased risk of CAD (OR: 1.16; 95% CI: 1.05–1.28). However, in European populations, the OR was 1.14 (95% CI: 1.01–1.28) whereas in North American populations the OR was 0.87 (95% CI: 0.73–1.05). It is known that use of vitamin supplementation, including folate, is higher in North America than in Europe (72). It is also known that the increase in homocysteine levels seen with the T allele is present only in the setting of low folate levels (73). In fact, when patients were stratified by folate status, the OR was 1.44 (95% CI: 1.12–1.83) in patients with low folate levels and 0.99 (95% CI: 0.77–1.29) in those with high folate levels. This gene–environment interaction illustrates a further potential layer of complexity when analyzing genetic data.

### ***Endothelial Nitric Oxide***

Ten SNPs have been identified in the *eNOS* gene, which encodes endothelial nitric oxide, an atheroprotective molecule. In a case–control study from Japan, there was a significant association between carriage of the Asp variant of the Glu298Asp SNP and MI (OR: 1.5; 95% CI: 1.2–1.8) (74). Subsequent case–control studies derived from Japanese and British populations confirmed the association, although the excess risk of MI was confined to individuals homozygous for the Asp variant (75,76). However, other studies have failed to demonstrate an association with MI (77,78), and no studies have found an association with extent of CAD. Other case–control studies have examined other SNPs and have reported associations between the 4a allele of intron 4 and MI (79,80), and the C allele of the –786 T/C promoter variant and multivessel CAD as well as endothelial dysfunction (81,82). There is evidence that each of these polymorphisms can alter endothelial nitric oxide synthase levels or function (83–85). A meta-analysis including 9867 cases and 13,161 controls found that homozygosity for the 298Asp allele (OR: 1.3; 95% CI: 1.1–1.5) and homozygosity for the 4a allele (OR: 1.3; 95% CI: 1.0–1.8), but not the –786C allele, was associated with ischemic heart disease (86).

### ***Estrogen Receptor***

Epidemiological studies have demonstrated that, compared with men, premenopausal women are relatively protected from the development of CVD. This difference has been attributed to estrogen and its effects on atherosclerosis, thrombosis, and inflammation. The relationship, though, is not straightforward, because several clinical trials have shown hormone therapy to be associated with an increased incidence of MI and stroke (87,88). However, the relevance of estrogen and its receptors extends to beyond women. Estrogen receptors are expressed on macrophages, vascular smooth muscle, and vascular endothelial cells and can be activated by both estrogen-dependent and estrogen-independent mechanisms. Several small studies investigated the association between polymorphisms in the estrogen receptor- $\alpha$  (*ESR1*) and CVD in both men and women, with varying results (89–91).

The association between genetic variation in *ESR1* and CVD was examined in two large cohort studies. In the first study, using 1739 individuals from the Framingham Offspring Cohort, the C/C genotype at position –397 in intron 1 was associated with acute MI (adjusted OR: 3.0; 95% CI: 1.7–5.2) (92). Interestingly, the second study, using 2617 men and 3791 postmenopausal women from the Rotterdam study and examining both the –397 T/C and –351 A/G SNPs, found that the T-A haplotype was associated with an increased risk of MI in women, both in those with one copy (adjusted OR: 2.2; 95% CI: 1.1–4.4) and in those with two copies (adjusted OR: 2.5; 95% CI: 1.2–5.0) (93). By contrast, in men the T-A haplotype was associated with reduced risk of MI (adjusted OR: 0.82; 95% CI: 0.49–1.38).

These differences illustrate the complexities of data interpretation even in large, well-conducted studies. At face value the conclusions appear contradictory (C allele associated with increased risk in the Framingham study, the opposite T allele associated with increased risk in the Rotterdam study). However, the results are compatible when taking into account gender. In the Framingham study, although women constituted half of the study population, the small number of MIs in women (5) vs in men (54) means that the increased risk associated with the C allele was driven by the results in men. An excess risk for the C allele can also be thought of as a protective effect for the T allele, a trend that was seen in men in the Rotterdam study. The small number of MIs in women in the Framingham study made it impossible for investigators to exclude the C allele from being protective (or the T allele being harmful) in women, as was observed in the Rotterdam study.

### *Prothrombotic Polymorphisms*

Given that ACSs are owing to intracoronary thrombosis, there has been much interest in exploring potential links between polymorphisms in genes encoding proteins involved in the coagulation cascade and the risk of MI. A meta-analysis has reviewed the data on four such polymorphisms (94). For factor V Leiden, the pooled OR for carriers was 1.26 (95% CI: 0.94–1.07). For the prothrombin G20210A polymorphism, the pooled OR was 0.89 (95% CI: 0.59–1.35). For both these polymorphisms, the association was stronger for premature MI, with ORs of 1.34 (95% CI: 0.94–1.91) for factor V Leiden and 1.86 (95% CI: 0.99–3.51) for prothrombin G20210A. Individuals homozygous for the plasminogen activator inhibitor-1 (PAI-1) 4G/5G promoter polymorphism were at an increased risk of MI (OR: 1.20; 95% CI: 1.04–1.39). However, the effect estimates approached unity as the individual study size increased, suggesting the presence of publication bias. Finally, individuals homozygous for the fibrinogen  $\beta$ -455 G/A promoter polymorphism were at a reduced risk of MI (OR: 0.66; 95% CI: 0.44–0.99). The Atherosclerosis, Thrombosis, and Vascular Biology Italian Study Group conducted a case–control study involving 1210 patients with premature MI (age <45 yr) and 1210 unrelated healthy control subjects (95). The investigators found no association between polymorphisms in genes encoding proteins involved in coagulation (fibrinogen  $\beta$ ; factors II, V, and VII), platelet function (GpIa and GpIIIa); fibrinolysis (PAI-1, factor XIII), or homocysteine metabolism (MTHFR).

### *Lipid Metabolism*

Lipids play a critical role in the progression of CAD. This central role has prompted investigators to examine polymorphisms in genes encoding lipoprotein and enzymes involved in lipid metabolism. Apolipoprotein B, the protein component of low-density lipoprotein (LDL), was a logical initial target of interest. In a small case–control study, the X1 allele of the RFLP defined by the endonuclease *Xba*I was associated with an increased risk of MI, although it was not associated with differences in LDL levels (96). Unfortunately, subsequent studies failed to validate the association with clinical events (97,98). However, they did demonstrate that LDL levels were 8 mg/dL higher in homozygotes for the variant allele (98).

#### **APOLIPOPROTEIN E**

Apolipoprotein E (apoE) is a component of very low-density lipoproteins and, via binding to receptors on the liver, plays a role in clearing cholesterol from the blood. Three iso-



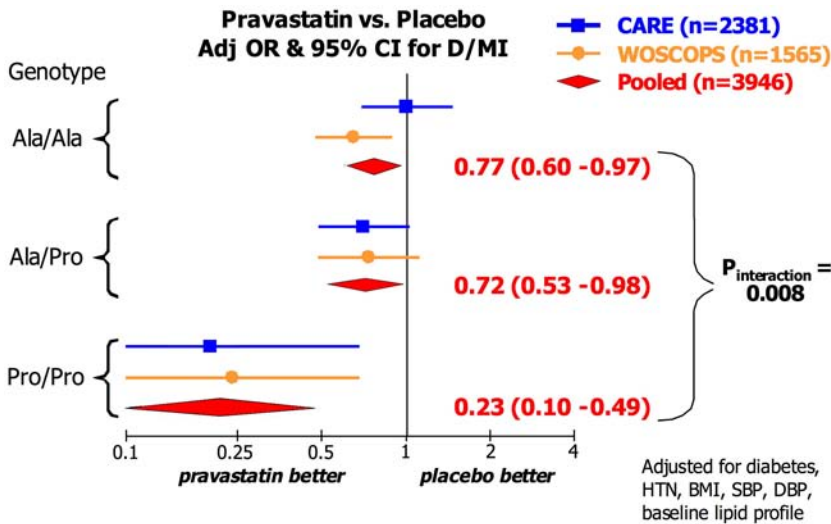
forms of apoE are known, apoE2, apoE3, and apoE4, coded by the *APOE*  $\epsilon$ 2,  $\epsilon$ 3, and  $\epsilon$ 4 alleles, respectively. The  $\epsilon$ 4 allele has been associated with higher circulating levels of LDL and an increased risk of CHD in both men (OR: 1.53;  $p = 0.04$ ) and women (OR: 1.99;  $p = 0.05$ ) (99). In a meta-analysis of nine studies, using the common  $\epsilon$ 3 allele as the reference, the  $\epsilon$ 2 allele was not associated with an increased risk of CHD (OR: 0.98; 95% CI: 0.85–1.14) but the  $\epsilon$ 4 allele was (OR: 1.26; 95% CI: 1.13–1.41) (100). Initial reports suggested that this risk was dependent on an individual's smoking status (101), but this was not confirmed in a large study (102). In the Scandinavian Simvastatin Survival Study (4S), carriers of the  $\epsilon$ 4 allele were at a significantly increased risk of dying (RR: 1.8; 95% CI: 1.1–3.1). Simvastatin treatment appeared to be twice as efficacious in the high-risk  $\epsilon$ 4 carriers (mortality risk reduction to 0.33) than in noncarriers (mortality risk reduction to 0.66), although the formal interaction test was nonsignificant ( $p = 0.23$ ) (103).

### CHOLESTERYL ESTER TRANSFER PROTEIN

Cholesteryl ester transfer protein (CETP) catalyzes the transfer of cholesteryl esters from high-density lipoprotein (HDL) to LDL, where they can then be taken up by the liver. Whether CETP is pro- or antiatherogenic remains a matter of debate. LDL particles with increased cholesteryl ester content are atherogenic, but the reverse transport of cholesterol from the periphery to the liver is antiatherogenic. Initial studies of the TaqIB RFLP in *CETP* demonstrated that B1 homozygotes had HDL levels 5 mg/dL higher than did B2 homozygotes, that B1 carriers had increased progression of coronary atherosclerosis, and that pravastatin therapy was more effective in slowing the progression of atherosclerosis in B1 homozygotes (104,105). The association between the TaqIB RFLP and HDL levels was validated in studies from the Framingham Offspring Study and the Veterans Affairs High-Density Lipoprotein Cholesterol Intervention Trial (VA-HIT) (106,107). In both of these studies the B1 variant was associated with an increased risk of CHD, although these associations were no longer significant after adjusting for other cardiac risk factors. Subsequently, the TaqIB RFLP was studied in the Cholesterol and Recurrent Events (CARE) trial (108), in which it was associated with HDL levels but not the risk of cardiovascular end points (109). Two other polymorphisms in *CETP* have been studied: Ile405Val and Ala373Pro. In a nested case-control study from the Copenhagen Heart Study, the 405Val variant was associated with higher levels of HDL in women and an increased risk of ischemic heart disease in women not treated with hormone replacement therapy (HRT) (110). Also in the Copenhagen Heart Study, the 373Pro variant was associated with lower levels of HDL in both men and women and a reduced risk of ischemic heart disease in women not treated with HRT (111). The possible interaction with HRT may reflect the fact that HRT alters HDL levels and may override any genetic effects.

### OTHER CANDIDATES IN LIPID METABOLISM

Examining 148 SNPs in 10 candidate genes related to lipid metabolism, Chasman et al. (112) found two tightly linked SNPs ( $r^2 = 0.90$ ) in the HMG-CoA reductase gene (*HMGCR*) that were associated with changes in lipid levels with pravastatin therapy. Individuals heterozygous for the variant (6.7% of the study cohort) had a 22% smaller reduction in total cholesterol and a 19% smaller reduction in LDL. These differences remained significant after correction for multiple testing. Neither SNP was associated with baseline lipid level, itself a predictor for the change seen with statin therapy. Both SNPs are located in introns and are far away from known splicing borders. Thus, these SNPs may be in tight linkage disequilibrium with the true causal variant.



**Fig. 2.** Interaction between ADAMTS-1 SNPs and efficacy of pravastatin therapy in two randomized controlled trials. D, death; MI, myocardial infarction; HTN, hypertension; BMI, body mass index; SBP, systolic blood pressure; DBP, diastolic blood pressure. (Adapted from ref. 113.)

As part of a large genotyping project, we have recently found an Ala210Pro polymorphism in the *ADAMTS-1* gene (which encodes a protein with metalloproteinase, disintegrin, and thrombospondin domains) that was significantly associated with both clinical outcomes and the efficacy of statin therapy (113). In 2421 Caucasian males from the CARE trial (108), the rate of death or MI was 9.5, 12.3, and 17.4% in individuals treated with placebo with 0, 1, or 2 copies of the 210Pro allele, respectively. By contrast, in those treated with pravastatin, the rates were 9.5, 9.2, and 4.8%. This translated into a significant treatment interaction between pravastatin therapy and genotype ( $P_{\text{interaction}} = 0.049$ ). These findings were then validated in the West of Scotland Coronary Prevention Study (WOSCOPS) study (114). Figure 2 shows the ORs for death or MI with pravastatin therapy stratified by genotype in the two trials. When the data from the two trials were pooled, the ORs for the reduction in death or MI with pravastatin were 0.77, 0.72, and 0.23 in individuals with 0, 1, or 2 copies of the 210Pro allele, respectively ( $P_{\text{interaction}} = 0.008$ ).

## LARGE MULTILOCUS STUDIES

The advent of high-throughput genotyping has enabled investigators to examine multiple genetic variants simultaneously in large study populations. Traditional statistical techniques such as the Bonferroni method are likely too conservative. Examination of 50 genotypes would require setting the  $p$  value at 0.001. Using the example provided earlier, with a minor allele frequency of 0.10 and an effect estimate of 1.20, would require close to 6500 case-control pairs. Other statistical approaches include controlling the false discovery rate and doing permutation testing (22,23). Finally, investigators have used a staged approach in which serial association studies are done with increasing conservative  $p$  value thresholds and only polymorphisms that show association in a prior stage moving forward.

In 2002, Yamada and colleagues published one of the largest genetic association studies for MI, studying 112 polymorphisms in 71 candidate genes in 5061 unrelated individuals

(134). They started with a screening study of the 112 SNPs stratified by gender in 909 of the 5061 individuals. Using a threshold of  $p < 0.1$ , they identified 19 candidate polymorphisms in men and 18 in women (note that with 112 tests and a  $p$  value threshold of 0.1, one would expect approx 11 statistically significant associations just by chance). Interestingly, of these polymorphisms, only four were common to both gender groups. The investigators then went on to validate these polymorphisms in the remaining 4152 individuals, with a  $p$  value threshold of  $< 0.001$ . They found three polymorphisms that met this criterion: in men, the C1019T SNP in the connexin 37 gene, and in women, the -668 4G/5G promoter variant in the PAI-1 gene and the -1171 5A/6A promoter variant in the stromelysin gene. In addition, the 242 C/T SNP in the p22<sup>phox</sup> gene was associated with MI in men, with a  $p$  value of 0.007. Surprisingly, no polymorphisms achieved significant associations in both men and women. This could be owing to estrogen and other hormonal factors interacting with potential genetic risk factors, or it could be owing to chance.

Two other, smaller multilocus studies have been published. Tobin and colleagues, from the Centre for Biostatistics and Genetic Epidemiology at the University of Leicester, examined 58 SNPs in 35 genes in 547 survivors of AMI and 505 control subjects (visitors to patients with non-CVD who themselves had no history of angina or MI) (135). Using an uncorrected threshold of  $p < 0.05$ , they found significant associations for two SNPs: -629 C/A in the *CETP* gene and gly460trp in the  $\alpha$ -adducin (*ADD1*) gene. They also examined haplotypes within 16 genes and found significant associations for the apolipoprotein C III (*APOC3*) and paraoxonase (*PON1* and *PON2*) genes. Although polymorphisms in these genes have been associated with CVD in other studies (115), the lack of correction for multiple testing tempers the credibility of these being true associations.

The GeneQuest investigators recruited Caucasian families with at least two siblings with premature, confirmed CAD or MI. Of these 762 siblings, 352 singletons were selected as case subjects and 418 individuals randomly selected from the population served as control subjects. They first examined 72 SNPs in 62 vascular biology genes (116). Eleven SNPs showed a significant association with CAD, MI, or both. Three of these were part of the thrombospondin (*THBS*) gene family, which encodes extracellular matrix glycoproteins that play a role in cell adhesion, vascular remodeling, coagulation, and angiogenesis (117). Homozygotes for an Asn700Ser mutation in *THBS-1* were at an increased risk of CAD, homozygotes for a T $\blacklozenge$ G variant in the 3' untranslated region (UTR) of *THBS-2* were at a reduced risk of MI, and carriers of Ala387Pro in *THBS-4* were at an increased risk of MI. However, it should be noted that with 72 SNPs and two end points, there were 144 statistical tests (not even counting the three different models: dominant, additive, or recessive). When correcting for multiple hypothesis testing, none of the associations maintained significance.

In a follow-up study, the investigators examined 210 SNPs in 111 candidate genes (118). For 40 of the genes, prior associations had been described. In this group, 10 genes were significantly associated with CAD or MI, including apoE (*APOE*), ACE (*ACE*), factor 7 (*F7*), fibrinogen (*FGB*), glycoprotein Ib (*GPIBA*), interleukin-1 receptor antagonist (*IL1RN*), LDL 1-related protein (*LRP1*), MTHFR (*MTHFR*), selectin P (*SELP*), and thrombopoietin (*THPO*). Among the remaining novel 71 genes, 11 were associated with CAD or MI, but after controlling for covariates, only three remained significant: *THBS-2*, *THBS-4*, and *PAI-2*. Again, no adjustments were made for multiple hypothesis testing.

Subsequent molecular biology studies offer some biological plausibility. In one study, compared to the asparagine variant, the serine variant of *THBS-1* displayed increased plate-

let surface expression and was associated with the rate and extent of platelet aggregation (119). In another study, the proline variant of *THBS-4* appeared to inhibit endothelial cell adhesion and proliferation and, thus, was potentially proatherogenic (120). However, in a larger study of 503 case subjects with premature CAD and 1071 control subjects (121), Dutch investigators found no association between the Asn700Ser mutation in *THBS-1* and premature CAD. They were able to replicate the protective effect of homozygosity for the T♦G variant in the 3' UTR of *THBS-2* and premature MI (OR: 0.44; 95% CI: 0.24–0.84). In contrast to the GeneQuest investigators, they found that carriers of the 387Pro variant of *THBS-4* were at reduced risk of premature MI (OR: 0.43; 95% CI: 0.22–0.95). Thus, the role of SNPs in thrombospondin genes in causing premature CAD remains controversial.

## GENOME-WIDE SCANS

Although a candidate gene approach in which a gene or genes encoding proteins relevant for cardiovascular biology is intuitively appealing, it is biased and constrained by the assumptions of the investigators. Therefore, several groups have attempted genome-wide scans using random, evenly spaced markers. In a study of 156 Finnish families with premature CAD, significant linkage was found at two loci: chromosome 2q21.1-22 and chromosome Xq23-26 (122). In a study of 99 Indian families with a member who had survived an ACS at an early age, significant linkage was found with a locus at chromosome 16p13.3 (123). In a study of 513 Western European families with premature MI or CAD, significant linkage was found at a locus on chromosome 14 (124). Finally, in a study of 61 Australian sibling pairs with a history of early ACSs, significant linkage was found with a locus at chromosome 2q36-37.3 (125). Whether the different loci identified in each study reflect different populations, different phenotypes, or false positives remains unclear. Certainly replication and finer mapping are warranted.

A group in Japan examined 92,788 SNPs in a large case–control study involving 1133 subjects with MI and 1006 control subjects (126). These investigators identified a candidate locus on chromosome 6p21 and within that region found three SNPs in the lymphotoxin- $\alpha$  (*LTA*) gene that were strongly associated with MI. Homozygosity for the +10 G/A allele (OR: 1.78; 95% CI: 1.39–2.27), homozygosity for the +252 A/G allele (OR: 1.69; 95% CI: 1.32–2.15), and homozygosity for the Thr26Asn allele (OR: 1.78; 95% CI: 1.39–2.27) all were associated with a significantly increased risk of MI. These SNPs defined a single haplotype tightly linked to MI. Subsequent molecular biology studies demonstrated that that 10A-252G haplotype displayed greater transcriptional activity, that the 252G allele bound nuclear factors more strongly, and that the 26Asn allele was more effective in inducing expression of cellular adhesion molecules.

Using a family with 21 members with an autosomal dominant pattern of CAD affecting 13 of them, a group from a Cleveland clinic employed a genomewide scan using 382 markers with an average interval of 10 cM (127). These investigators found significant linkage between CAD and one of their markers on chromosome 15q26 with a logarithm of the odds (LOD) score of 4.19. The candidate region contained 93 genes: 43 known and 50 hypothetical. One of the known candidate genes was a member of the myocyte enhancer factor-2 family (*MEF2A*), a transcription factor that may play an important role in angiogenesis (128–130). The researchers then performed mutational screening and found that all 10 of the living affected family members had a seven amino acid deletion in a highly conserved region of the *MEF2A* gene. They screened 119 unrelated healthy individuals,

none of whom had the mutation. Cellular localization studies demonstrated that the seven amino acid mutation caused a marked defect in MEF2A intracellular trafficking, with a block of MEF2A entry into the nucleus. In transcription activation assays, the mutant MEF2A protein had only one-third the activity of the wild-type protein and appeared to act via a dominant-negative mechanism. Although the biology is very compelling, it should be noted that this association was seen in only one family. In fact, when the investigators examined three other large families with CAD, there was no linkage to this locus. Moreover, when they performed mutational analysis in 50 sporadic patients with CAD, none of them had any mutations in *MEF2A*.

The deCODE genetics group in Iceland published the results of a genomewide scan in which they genotyped 296 extended families, including 713 members with a history of MI, with 1068 microsatellite markers (specific sequences of tandem repeats) (131). These investigators found reasonably strong evidence of linkage disequilibrium (LOD score of 2.86) with a locus on chromosome 13q12-13. Finer mapping of this area identified the gene *ALOX5AP*, which encodes the 5-lipoxygenase activating protein. Sequencing this gene, they identified a haplotype (HapA, defined by four SNPs) that was carried by 29.1% of the population and that conferred an RR of MI of 1.80, with a *p* value after adjustment for multiple comparisons of 0.005. Interestingly, they attempted to validate these findings in a separate population derived from a cohort of British individuals. In that group, carriage of HapA was not associated with a significantly increased risk of MI. However, carriage of a different haplotype (HapB) was associated with a nearly twofold increased risk of MI (adjusted *p* value of 0.046). The different haplotypes associated with MI in the two populations may be owing to the fact that the SNPs that define the haplotype are not themselves causal. Rather, they may be in tight linkage disequilibrium with the true causal mutation. However, this mutation may have arisen in different haplotypic backgrounds in different populations. In support of the role of the eicosanoid pathway in the pathogenesis of atherosclerosis, a different research team identified polymorphisms in the promoter region of the gene encoding 5-lipoxygenase (*ALOX5*) to be associated with carotid artery intimal-media thickness (132). They also demonstrated significant diet-gene interactions, with *n*-6 polyunsaturated fatty acids promoting and *n*-3 marine fatty acids inhibiting development of the atherosclerotic phenotype.

## CONCLUSION

Currently, it is clear that no genetic markers are ready for widespread adoption as risk factors for CHD. Yet, there is good reason to be hopeful. There are several promising, biologically plausible candidates. Learning from early forays, researchers are now designing larger and better studies in order to maximize the chances of detecting these subtle but likely important contributors to CHD. The ultimate goal is to be able to identify patients at high risk of CHD and tailor therapies in order to minimize patients' morbidity and mortality.

## REFERENCES

1. Mendel G. Versuche über Pflanzenshybriden. Verhandlungen des naturforschenden Vereines in Brünn, 1865.
2. Fisher RA. The correlation between relatives on the supposition of Mendelian inheritance. *Trans R Soc Edinb* 1918;52:399–433.
3. Rose G. Familial patterns in ischemic heart disease. *Br J Prev Soc Med* 1964;18:75–80.

4. Slack J, Evan KA. The increased risk of death from ischaemic heart disease in first-degree relatives of 121 men and 96 women with ischaemic heart disease. *J Med Genet* 1966;3.
5. Rissanen AM, Nikkila EA. Coronary artery disease and its risk factors in families of young men with angina pectoris and in controls. *Br Heart J* 1977;39:875–883.
6. Thordarson O, Fridriksson S. Aggregation of deaths with ischaemic heart disease among first and second degree relatives of 108 males and 42 females with myocardial infarction. *Acta Med Scand* 1979; 205:493–500.
7. Jorde LB, Williams RR. Relation between family history of coronary artery disease and coronary risk variables. *Am J Cardiol* 1988;62:708–713.
8. Sorensen TI, Nielsen GG, Andersen PK, Teasdale TW. Genetic and environmental influences on premature death in adult adoptees. *N Engl J Med* 1988;318:727–732.
9. Marenberg ME, Risch N, Berkman LF, Floderus B, de Faire U. Genetic susceptibility to death from coronary heart disease in a study of twins. *N Engl J Med* 1994;330:1041–1046.
10. Risch NJ. Searching for genetic determinants in the new millennium. *Nature* 2000;405:847–856.
11. Cardon LR, Bell JI. Association study designs for complex diseases. *Nat Rev Genet* 2001;2:91–99.
12. Risch N, Merikangas K. The future of genetic studies of complex human diseases. *Science* 1996;273: 1516, 1517.
13. Johnson GC, Esposito L, Barratt BJ, et al. Haplotype tagging for the identification of common disease genes. *Nat Genet* 2001;29:233–237.
14. Collins FS, Guyer MS, Chakravarti A. Variations on a theme: cataloging human DNA sequence variation. *Science* 1997;278:1580, 1581.
15. Brzustowicz LM, Merette C, Xie X, Townsend L, Gilliam TC, Ott J. Molecular and statistical approaches to the detection and correction of errors in genotype databases. *Am J Hum Genet* 1993;53:1137–1145.
16. Chakraborty R, Weiss KM. Admixture as a tool for finding linked genes and detecting that difference from allelic association between loci. *Proc Natl Acad Sci USA* 1988;85:9119–9923.
17. Lander ES, Schork NJ. Genetic dissection of complex traits. *Science* 1994;265:2037–2048.
18. Devlin B, Roeder K. Genomic control for association studies. *Biometrics* 1999;55:997–1004.
19. Pritchard JK, Rosenberg NA. Use of unlinked genetic markers to detect population stratification in association studies. *Am J Hum Genet* 1999;65:220–228.
20. Reich DE, Goldstein DB. Detecting association in a case-control study while correcting for population stratification. *Genet Epidemiol* 2001;20:4–16.
21. Brown BWJ, Hollander M. *Statistics: A Biomedical Introduction*. Wiley, New York, 1977.
22. Benjamini Y, Hochberg Y. Controlling the false discovery rate: a practical and powerful approach to multiple testing. *J R Statist Soc B* 1995;57:289–300.
23. Doerge RW, Churchill GA. Permutation tests for multiple loci affecting a quantitative character. *Genetics* 1996;142:285–294.
24. Lander E, Kruglyak L. Genetic dissection of complex traits: guidelines for interpreting and reporting linkage results. *Nat Genet* 1995;11:241–247.
25. Lohmueller KE, Pearce CL, Pike M, Lander ES, Hirschhorn JN. Meta-analysis of genetic association studies supports a contribution of common variants to susceptibility to common disease. *Nat Genet* 2003; 33:177–182.
26. Easterbrook PJ, Berlin JA, Gopalan R, Matthews DR. Publication bias in clinical research. *Lancet* 1991; 337:867–872.
27. Egger M, Davey Smith G, Schneider M, Minder C. Bias in meta-analysis detected by a simple, graphical test. *BMJ* 1997;315:629–634.
28. Begg CB, Mazumdar M. Operating characteristics of a rank correlation test for publication bias. *Biometrics* 1994;50:1088–1101.
29. Ioannidis JP, Trikalinos TA, Ntzani EE, Contopoulos-Ioannidis DG. Genetic associations in large versus small studies: an empirical assessment. *Lancet* 2003;361:567–571.
30. Lusic AJ. Genetic factors in cardiovascular disease: 10 questions. *Trends Cardiovasc Med* 2003;13: 309–316.
31. Winkelmann BR, Hager J, Kraus WE, et al. Genetics of coronary heart disease: current knowledge and research principles. *Am Heart J* 2000;140:S11–S26.
32. Weiss EJ, Bray PF, Tayback M, et al. A polymorphism of a platelet glycoprotein receptor as an inherited risk factor for coronary thrombosis. *N Engl J Med* 1996;334:1090–1094.
33. Goldschmidt-Clermont PJ, Shear WS, Schwartzberg J, Varga CF, Bray PF. Clues to the death of an Olympic champion. *Lancet* 1996;347:1833.

34. Carter AM, Ossei-Gerning N, Grant PJ. Platelet glycoprotein IIIa PI<sup>A</sup> polymorphism in young men with myocardial infarction. *Lancet* 1996;348:485, 486.
35. Walter DH, Schachinger V, Elsner M, Dimmeler S, Zeiher AM. Platelet glycoprotein IIIa polymorphisms and risk of coronary stent thrombosis. *Lancet* 1997;350:1217–1219.
36. Kastrati A, Schomig A, Seyfarth M, et al. PIA polymorphism of platelet glycoprotein IIIa and risk of restenosis after coronary stent placement. *Circulation* 1999;99:1005–1010.
37. Feng D, Lindpaintner K, Larson MG, et al. Increased platelet aggregability associated with platelet GPIIIa PIA2 polymorphism: the Framingham Offspring Study. *Arterioscl Thromb Vasc Biol* 1999;19:1142–1147.
38. Michelson AD, Furman MI, Goldschmidt-Clermont P, et al. Platelet GP IIIa PI(A) polymorphisms display different sensitivities to agonists. *Circulation* 2000;101:1013–1018.
39. Ridker PM, Hennekens CH, Schmitz C, Stampfer MJ, Lindpaintner K. PI<sup>A1/A2</sup> polymorphism of platelet glycoprotein IIIa and risks of myocardial infarction, stroke, and venous thrombosis. *Lancet* 1997;349:385–388.
40. Aleksic N, Juneja H, Folsom AR, et al. Platelet PI(A2) allele and incidence of coronary heart disease: results from the Atherosclerosis Risk in Communities (ARIC) Study. *Circulation* 2000;102:1901–1905.
41. Laule M, Cascorbi I, Stangl V, et al. A1/A2 polymorphism of glycoprotein IIIa and association with excess procedural risk for coronary catheter interventions: a case-controlled study. *Lancet* 1999;353:708–712.
42. Zhu MM, Weedon J, Clark LT. Meta-analysis of the association of platelet glycoprotein IIIa PIA1/A2 polymorphism with myocardial infarction. *Am J Cardiol* 2000;86:1000–1005, A8.
43. Di Castelnuovo A, de Gaetano G, Donati MB, Iacoviello L. Platelet glycoprotein receptor IIIa polymorphism PLA1/PLA2 and coronary risk: a meta-analysis. *Thromb Haemost* 2001;85:626–633.
44. Bojesen SE, Juul K, Schnohr P, Tybjaerg-Hansen A, Nordestgaard BG. Platelet glycoprotein IIb/IIIa PI(A2)/PI(A2) homozygosity associated with risk of ischemic cardiovascular disease and myocardial infarction in young men: the Copenhagen City Heart Study. *J Am Coll Cardiol* 2003;42:661–667.
45. Cannon CP, McCabe CH, Wilcox RG, et al. Oral glycoprotein IIb/IIIa inhibition with orbofiban in patients with unstable coronary syndromes (OPUS-TIMI 16) trial. *Circulation* 2000;102:149–156.
46. O'Connor FF, Shields DC, Fitzgerald A, Cannon CP, Braunwald E, Fitzgerald DJ. Genetic variation in glycoprotein IIb/IIIa (GPIIb/IIIa) as a determinant of the responses to an oral GPIIb/IIIa antagonist in patients with unstable coronary syndromes. *Blood* 2001;98:3256–3260.
47. Cox D, Smith R, Quinn M, Theroux P, Crean P, Fitzgerald DJ. Evidence of platelet activation during treatment with a GPIIb/IIIa antagonist in patients presenting with acute coronary syndromes. *J Am Coll Cardiol* 2000;36:1514–1519.
48. Holmes MB, Sobel BE, Cannon CP, Schneider DJ. Increased platelet reactivity in patients given orbofiban after an acute coronary syndrome: an OPUS-TIMI 16 substudy. *Am J Cardiol* 2000;85:491–493.
49. Rigat B, Hubert C, Alhenc-Gelas F, Cambien F, Corvol P, Soubrier F. An insertion/deletion polymorphism in the angiotensin I-converting enzyme gene accounting for half the variance of serum enzyme levels. *J Clin Invest* 1990;86:1343–1346.
50. Mighell AJ, Markham AF, Robinson PA. Alu sequences. *FEBS Lett* 1997;417:1–5.
51. Tiret L, Rigat B, Visvikis S, et al. Evidence, from combined segregation and linkage analysis, that a variant of the angiotensin I-converting enzyme (ACE) gene controls plasma ACE levels. *Am J Hum Genet* 1992;51:197–205.
52. Cambien F, Poirier O, Lecerf L, et al. Deletion polymorphism in the gene for angiotensin-converting enzyme is a potent risk factor for myocardial infarction. *Nature* 1992;359:641–644.
53. Samani NJ, Thompson JR, O'Toole L, Channer K, Woods KL. A meta-analysis of the association of the deletion allele of the angiotensin-converting enzyme gene with myocardial infarction. *Circulation* 1996;94:708–712.
54. Keavney B, McKenzie C, Parish S, et al. Large-scale test of hypothesised associations between the angiotensin-converting-enzyme insertion/deletion polymorphism and myocardial infarction in about 5000 cases and 6000 controls: International Studies of Infarct Survival (ISIS) Collaborators. *Lancet* 2000;355:434–442.
55. Agema WR, Jukema JW, Zwinderman AH, van der Wall EE. A meta-analysis of the angiotensin-converting enzyme gene polymorphism and restenosis after percutaneous transluminal coronary revascularization: evidence for publication bias. *Am Heart J* 2002;144:760–768.
56. Bonnici F, Keavney B, Collins R, Danesh J. Angiotensin converting enzyme insertion or deletion polymorphism and coronary restenosis: meta-analysis of 16 studies. *BMJ* 2002;325:517–520.

57. Jeunemaitre X, Lifton RP, Hunt SC, Williams RR, Lalouel JM. Absence of linkage between the angiotensin converting enzyme locus and human essential hypertension. *Nat Genet* 1992;1:72–75.
58. O'Donnell CJ, Lindpaintner K, Larson MG, et al. Evidence for association and genetic linkage of the angiotensin-converting enzyme locus with hypertension and blood pressure in men but not women in the Framingham Heart Study. *Circulation* 1998;97:1766–1772.
59. Clarke R, Daly L, Robinson K, et al. Hyperhomocysteinemia: an independent risk factor for vascular disease. *N Engl J Med* 1991;324:1149–1155.
60. Boushey CJ, Beresford SA, Omenn GS, Motulsky AG. A quantitative assessment of plasma homocysteine as a risk factor for vascular disease: probable benefits of increasing folic acid intakes [see comments]. *JAMA* 1995;274:1049–1057.
61. Kang SS, Zhou J, Wong PW, Kowalysyn J, Strokosch G. Intermediate homocysteinemia: a thermolabile variant of methylenetetrahydrofolate reductase. *Am J Hum Genet* 1988;43:414–421.
62. Frosst P, Blom HJ, Milos R, et al. A candidate genetic risk factor for vascular disease: a common mutation in methylenetetrahydrofolate reductase. *Nat Genet* 1995;10:111–113.
63. Gallagher PM, Meleady R, Shields DC, et al. Homocysteine and risk of premature coronary heart disease: evidence for a common gene mutation. *Circulation* 1996;94:2154–2158.
64. Kluijtmans LA, Kastelein JJ, Lindemans J, et al. Thermolabile methylenetetrahydrofolate reductase in coronary artery disease. *Circulation* 1997;96:2573–2577.
65. Schmitz C, Lindpaintner K, Verhoef P, Gaziano JM, Buring J. Genetic polymorphism of methylenetetrahydrofolate reductase and myocardial infarction: a case-control study. *Circulation* 1996;94:1812–1814.
66. Ma J, Stampfer MJ, Hennekens CH, et al. Methylenetetrahydrofolate reductase polymorphism, plasma folate, homocysteine, and risk of myocardial infarction in US physicians. *Circulation* 1996;94:2410–2416.
67. Schwartz SM, Siscovick DS, Malinow MR, et al. Myocardial infarction in young women in relation to plasma total homocysteine, folate, and a common variant in the methylenetetrahydrofolate reductase gene. *Circulation* 1997;96:412–417.
68. Anderson JL, King GJ, Thomson MJ, et al. A mutation in the methylenetetrahydrofolate reductase gene is not associated with increased risk for coronary artery disease or myocardial infarction. *J Am Coll Cardiol* 1997;30:1206–1211.
69. Folsom AR, Nieto FJ, McGovern PG, et al. Prospective study of coronary heart disease incidence in relation to fasting total homocysteine, related genetic polymorphisms, and B vitamins: the Atherosclerosis Risk in Communities (ARIC) study. *Circulation* 1998;98:204–210.
70. Verhoef P, Rimm EB, Hunter DJ, et al. A common mutation in the methylenetetrahydrofolate reductase gene and risk of coronary heart disease: results among U.S. men. *J Am Coll Cardiol* 1998;32:353–359.
71. Klerk M, Verhoef P, Clarke R, Blom HJ, Kok FJ, Schouten EG. MTHFR 677C♦T polymorphism and risk of coronary heart disease: a meta-analysis. *JAMA* 2002;288:2023–2031.
72. Rimm EB, Willett WC, Hu FB, et al. Folate and vitamin B6 from diet and supplements in relation to risk of coronary heart disease among women. *JAMA* 1998;279:359–364.
73. Malinow MR, Nieto FJ, Kruger WD, et al. The effects of folic acid supplementation on plasma total homocysteine are modulated by multivitamin use and methylenetetrahydrofolate reductase genotypes. *Arterioscl Thromb Vasc Biol* 1997;17:1157–1162.
74. Shimasaki Y, Yasue H, Yoshimura M, et al. Association of the missense Glu298Asp variant of the endothelial nitric oxide synthase gene with myocardial infarction. *Circulation* 1998;31:1506–1510.
75. Hibi K, Ishigami T, Tamura K, et al. Endothelial nitric oxide synthase gene polymorphism and acute myocardial infarction. *Hypertension* 1998;32:521–526.
76. Hingorani AD, Liang CF, Fatibene J, et al. A common variant of the endothelial nitric oxide synthase (Glu<sup>298</sup>♦Asp) is a major risk factor for coronary artery disease in the UK. *Circulation* 1999;100:1515–1520.
77. Poirier O, Mao C, Mallet C, et al. Polymorphisms of the endothelial nitric oxide synthase gene—no consistent association with myocardial infarction in the ECTIM study. *Eur J Clin Invest* 1999;29:284–290.
78. Jeerooburkhan N, Jones LC, Bujac S, et al. Genetic and environmental determinants of plasma nitrogen oxides and risk of ischemic heart disease. *Hypertension* 2001;38:1054–1061.
79. Wang XL, Sim AS, Badenhop RF, McCredie RM, Wilcken DE. A smoking-dependent risk of coronary artery disease associated with a polymorphism of the endothelial nitric oxide synthase gene. *Nat Med* 1996;2:41–45.



80. Fatini C, Sofi F, Sticchi E, et al. Influence of endothelial nitric oxide synthase gene polymorphisms (G894T, 4a4b, T-786C) and hyperhomocysteinemia on the predisposition to acute coronary syndromes. *Am Heart J* 2004;147:516–521.
81. Rossi GP, Cesari M, Zanchetta M, et al. The T-786C endothelial nitric oxide synthase genotype is a novel risk factor for coronary artery disease in Caucasian patients of the GENICA study. *J Am Coll Cardiol* 2003;41:930–937.
82. Rossi GP, Taddei S, Virdis A, et al. The T-786C and Glu298Asp polymorphisms of the endothelial nitric oxide gene affect the forearm blood flow responses of Caucasian hypertensive patients. *J Am Coll Cardiol* 2003;41:938–945.
83. Tesauro M, Thompson WC, Rogliani P, Qi L, Chaudhary PP, Moss J. Intracellular processing of endothelial nitric oxide synthase isoforms associated with differences in severity of cardiopulmonary diseases: cleavage of proteins with aspartate vs. glutamate at position 298. *Proc Natl Acad Sci USA* 2000;97:2832–2835.
84. Wang XL, Mahaney MC, Sim AS, et al. Genetic contribution of the endothelial constitutive nitric oxide synthase gene to plasma nitric oxide levels. *Arterioscl Thromb Vasc Biol* 1997;17:3147–3153.
85. Nakayama M, Yasue H, Yoshimura M, et al. T-786C mutation in the 5'-flanking region of the endothelial nitric oxide synthase gene is associated with coronary spasm. *Circulation* 1999;99:2864–2870.
86. Casas JP, Bautista LE, Humphries SE, Hingorani AD. Endothelial nitric oxide synthase genotype and ischemic heart disease: meta-analysis of 26 studies involving 23028 subjects. *Circulation* 2004;109:1359–1365.
87. Rossouw JE, Anderson GL, Prentice RL, et al. Risks and benefits of estrogen plus progestin in healthy postmenopausal women: principal results From the Women's Health Initiative randomized controlled trial. *JAMA* 2002;288:321–333.
88. Anderson GL, Limacher M, Assaf AR, et al. Effects of conjugated equine estrogen in postmenopausal women with hysterectomy: the Women's Health Initiative randomized controlled trial. *JAMA* 2004;291:1701–1712.
89. Matsubara Y, Murata M, Kawano K, et al. Genotype distribution of estrogen receptor polymorphisms in men and postmenopausal women from healthy and coronary populations and its relation to serum lipid levels. *Arterioscl Thromb Vasc Biol* 1997;17:3006–3012.
90. Kunnas TA, Laippala P, Penttila A, Lehtimaki T, Karhunen PJ. Association of polymorphism of human alpha oestrogen receptor gene with coronary artery disease in men: a necropsy study. *BMJ* 2000;321:273,274.
91. Lu H, Higashikata T, Inazu A, et al. Association of estrogen receptor-alpha gene polymorphisms with coronary artery disease in patients with familial hypercholesterolemia. *Arterioscl Thromb Vasc Biol* 2002;22:817–823.
92. Shearman AM, Cupples LA, Demissie S, et al. Association between estrogen receptor alpha gene variation and cardiovascular disease. *JAMA* 2003;290:2263–2270.
93. Schuit SC, Oei HH, Witteman JC, et al. Estrogen receptor alpha gene polymorphisms and risk of myocardial infarction. *JAMA* 2004;291:2969–2977.
94. Boekholdt SM, Bijsterveld NR, Moons AH, Levi M, Buller HR, Peters RJ. Genetic variation in coagulation and fibrinolytic proteins and their relation with acute myocardial infarction: a systematic review. *Circulation* 2001;104:3063–3068.
95. Atherosclerosis T, and Vascular Biology Italian Study Group. No evidence of association between prothrombotic gene polymorphisms and the development of acute myocardial infarction at a young age. *Circulation* 2003;107:1117–1122.
96. Hegele RA, Huang LS, Herbert PN, et al. Apolipoprotein B-gene DNA polymorphisms associated with myocardial infarction. *N Engl J Med* 1986;315:1509–1515.
97. Marshall HW, Morrison LC, Wu LL, et al. Apolipoprotein polymorphisms fail to define risk of coronary artery disease: results of a prospective, angiographically controlled study. *Circulation* 1994;89:567–577.
98. Turner PR, Talmud PJ, Visvikis S, Ehnholm C, Tiret L. DNA polymorphisms of the apoprotein B gene are associated with altered plasma lipoprotein concentrations but not with perceived risk of cardiovascular disease: European Atherosclerosis Research Study. *Atherosclerosis* 1995;116:221–234.
99. Wilson PW, Myers RH, Larson MG, Ordovas JM, Wolf PA, Schaefer EJ. Apolipoprotein E alleles, dyslipidemia, and coronary heart disease: The Framingham Offspring Study. *JAMA* 1994;272:1666–1671.
100. Wilson PW, Schaefer EJ, Larson MG, Ordovas JM. Apolipoprotein E alleles and risk of coronary disease: a meta-analysis. *Arterioscl Thromb Vasc Biol* 1996;16:1250–1255.

101. Humphries SE, Talmud PJ, Hawe E, Bolla M, Day IN, Miller GJ. Apolipoprotein E4 and coronary heart disease in middle-aged men who smoke: a prospective study. *Lancet* 2001;358:115–119.
102. Keavney B, Parish S, Palmer A, et al. Large-scale evidence that the cardiotoxicity of smoking is not significantly modified by the apolipoprotein E epsilon2/epsilon3/epsilon4 genotype. *Lancet* 2003;361:396–398.
103. Gerdes LU, Gerdes C, Kervinen K, et al. The apolipoprotein epsilon4 allele determines prognosis and the effect on prognosis of simvastatin in survivors of myocardial infarction: a substudy of the Scandinavian simvastatin survival study. *Circulation* 2000;101:1366–1371.
104. Kuivenhoven JA, de Knijff P, Boer JM, et al. Heterogeneity at the CETP gene locus: influence on plasma CETP concentrations and HDL cholesterol levels. *Arterioscl Thromb Vasc Biol* 1997;17:560–568.
105. Kuivenhoven JA, Jukema JW, Zwinderman AH, et al. The role of a common variant of the cholesteryl ester transfer protein gene in the progression of coronary atherosclerosis: The Regression Growth Evaluation Statin Study Group. *N Engl J Med* 1998;338:86–93.
106. Ordovas JM, Cupples LA, Corella D, et al. Association of cholesteryl ester transfer protein-TaqIB polymorphism with variations in lipoprotein subclasses and coronary heart disease risk: the Framingham study. *Arterioscl Thromb Vasc Biol* 2000;20:1323–1329.
107. Brousseau ME, O'Connor JJ Jr, Ordovas JM, et al. Cholesteryl ester transfer protein TaqI B2B2 genotype is associated with higher HDL cholesterol levels and lower risk of coronary heart disease end points in men with HDL deficiency: Veterans Affairs HDL Cholesterol Intervention Trial. *Arterioscl Thromb Vasc Biol* 2002;22:1148–1154.
108. Sacks FM, Pfeffer MA, Moye LA, et al. The effect of pravastatin on coronary events after myocardial infarction in patients with average cholesterol levels. *N Engl J Med* 1996;335:1001–1009.
109. de Grooth GJ, Zerba KE, Huang SP, et al. The cholesteryl ester transfer protein (CETP) TaqIB polymorphism in the cholesterol and recurrent events study: no interaction with the response to pravastatin therapy and no effects on cardiovascular outcome: a prospective analysis of the CETP TaqIB polymorphism on cardiovascular outcome and interaction with cholesterol-lowering therapy. *J Am Coll Cardiol* 2004;43:854–857.
110. Agerholm-Larsen B, Nordestgaard BG, Steffensen R, Jensen G, Tybjaerg-Hansen A. Elevated HDL cholesterol is a risk factor for ischemic heart disease in white women when caused by a common mutation in the cholesteryl ester transfer protein gene. *Circulation* 2000;101:1907–1912.
111. Agerholm-Larsen B, Tybjaerg-Hansen A, Schnohr P, Steffensen R, Nordestgaard BG. Common cholesteryl ester transfer protein mutations, decreased HDL cholesterol, and possible decreased risk of ischemic heart disease: the Copenhagen City heart study. *Circulation* 2000;102:2197–2203.
112. Chasman DI, Posada D, Subrahmanyam L, Cook NR, Stanton VP Jr, Ridker PM. Pharmacogenetic study of statin therapy and cholesterol reduction. *JAMA* 2004;291:2821–2827.
113. Sabatine MS, Ray KK, Iakoubova OA, et al. A polymorphism in a metalloproteinase gene predicts ability of pravastatin to reduce death or MI. *Circulation* 2004;110(Suppl III):III–426.
114. Shepherd J, Cobbe SM, Ford I, et al. Prevention of coronary heart disease with pravastatin in men with hypercholesterolemia. *N Engl J Med* 1995;333:1301–1307.
115. Psaty BM, Smith NL, Heckbert SR, et al. Diuretic therapy, the alpha-adducin gene variant, and the risk of myocardial infarction or stroke in persons with treated hypertension. *JAMA* 2002;287:1680–1689.
116. Topol EJ, McCarthy J, Gabriel S, et al. Single nucleotide polymorphisms in multiple novel thrombospondin genes may be associated with familial premature myocardial infarction. *Circulation* 2001;104:2641–2644.
117. Bornstein P. Thrombospondins as matricellular modulators of cell function. *J Clin Invest* 2001;107:929–934.
118. McCarthy JJ, Parker A, Salem R, et al. Large scale association analysis for identification of genes underlying premature coronary heart disease: cumulative perspective from analysis of 111 candidate genes. *J Med Genet* 2004;41:334–341.
119. Narizhneva NV, Byers-Ward VJ, Quinn MJ, et al. Molecular and functional differences induced in thrombospondin-1 by the single nucleotide polymorphism associated with the risk of premature, familial myocardial infarction. *J Biol Chem* 2004;279:21,651–21,657.
120. Stenina OI, Desai SY, Krukovets I, et al. Thrombospondin-4 and its variants: expression and differential effects on endothelial cells. *Circulation* 2003;108:1514–1519.
121. Boekholdt SM, Trip MD, Peters RJ, et al. Thrombospondin-2 polymorphism is associated with a reduced risk of premature myocardial infarction. *Arterioscl Thromb Vasc Biol* 2002;22:e24–e27.

122. Pajukanta P, Cargill M, Viitanen L, et al. Two loci on chromosomes 2 and X for premature coronary heart disease identified in early- and late-settlement populations of Finland. *Am J Hum Genet* 2000;67:1481–1493.
123. Francke S, Manraj M, Lacquemant C, et al. A genome-wide scan for coronary heart disease suggests in Indo-Mauritians a susceptibility locus on chromosome 16p13 and replicates linkage with the metabolic syndrome on 3q27. *Hum Mol Genet* 2001;10:2751–2765.
124. Broeckel U, Hengstenberg C, Mayer B, et al. A comprehensive linkage analysis for myocardial infarction and its related risk factors. *Nat Genet* 2002;30:210–214.
125. Harrap SB, Zammit KS, Wong ZY, et al. Genome-wide linkage analysis of the acute coronary syndrome suggests a locus on chromosome 2. *Arterioscl Thromb Vasc Biol* 2002;22:874–878.
126. Ozaki K, Ohnishi Y, Iida A, et al. Functional SNPs in the lymphotoxin-alpha gene that are associated with susceptibility to myocardial infarction. *Nat Genet* 2002;32:650–654.
127. Wang L, Fan C, Topol SE, Topol EJ, Wang Q. Mutation of MEF2A in an inherited disorder with features of coronary artery disease. *Science* 2003;302:1578–1581.
128. Edmondson DG, Lyons GE, Martin JF, Olson EN. Mef2 gene expression marks the cardiac and skeletal muscle lineages during mouse embryogenesis. *Development* 1994;120:1251–1263.
129. Black BL, Olson EN. Transcriptional control of muscle development by myocyte enhancer factor-2 (MEF2) proteins. *Annu Rev Cell Dev Biol* 1998;14:167–196.
130. Subramanian SV, Nadal-Ginard B. Early expression of the different isoforms of the myocyte enhancer factor-2 (MEF2) protein in myogenic as well as non-myogenic cell lineages during mouse embryogenesis. *Mech Dev* 1996;57:103–112.
131. Helgadottir A, Manolescu A, Thorleifsson G, et al. The gene encoding 5-lipoxygenase activating protein confers risk of myocardial infarction and stroke. *Nat Genet* 2004;36:233–239.
132. Dwyer JH, Allayee H, Dwyer KM, et al. Arachidonate 5-lipoxygenase promoter genotype, dietary arachidonic acid, and atherosclerosis. *N Engl J Med* 2004;350:29–37.
133. Lusis AJ, Fogelman AM, Fomarov GC. Genetic basis of atherosclerosis. Part I: New genes and pathways. *Circulation* 2004;100:1868–1873.
134. Yamada Y, Izama H, Ichihara S. Prediction of the risk of myocardial infarction from polymorphisms in candidate genes. *N Engl J Med* 2002;347:1916–1933.
135. Tobin MD, Braund PS, Burton PR, et al. Genotypes and haplotypes predisposing to myocardial infarction: a multilocus case-control study. *Eur Heart J* 2004;25:459–467.

# INDEX

---

## A

ACE, *see* Angiotensin-converting enzyme

ACS, *see* Acute coronary syndrome

Activity measurement, definition, 6

Acute coronary syndrome (ACS), *see also*  
Non-ST-elevation acute coronary  
syndrome,

B-type natriuretic peptide prognostic  
value,

B-type natriuretic peptide, 415, 416,  
418

combination with other risk markers,  
421

N-terminal fragment of prohormone,  
418

patient selection for early  
intervention, 420

recommendations, 420, 421

risk stratification, 419

timing of measurement, 418, 419

biomarker applications,

diagnosis, 180, 181

pathophysiology, 180

risk stratification, 178–180, 278

C-reactive protein in risk stratification,

clinical decision making, 270

comparison with other inflammatory  
markers, 266, 267

cut-off values, 265, 266

patient subgroups, 272

percutaneous coronary intervention  
outcome prediction, 266

prognostic value, 262–264, 279, 280  
prospects, 272

timing of testing, 270, 272

clinical spectrum, 4, 61

diagnostic limitations, 194, 195

etiology, 194

etiology, 546

inflammation, 212, 214, 261, 262

multimarker approach in evaluation,

CD40 ligand, 552, 553

modeling approaches, 553, 554

necrosis markers, 548

novel biomarker importance, 547, 548,  
551, 552

prospects, 546, 547

strategy development,

risk relationship heterogeneity, 554,  
555

therapy implications, 555, 556

troponin combination,

B-type natriuretic peptide, 549, 550

C-reactive protein, 549

triple markers, 550–552

pathophysiology, 4

point-of-care testing,

clinical decision making, 569

decision limits, 569, 570

diagnosis, 567, 568

impact on outcomes, 570

risk stratification, 568, 569

prognostic factors, 410, 411

*ADAMTS-1*, polymorphisms and  
cardiovascular disease, 599

Adhesion molecules, heart failure levels,  
307, 308

ADIFAB, myocardial ischemia detection, 186

Adiponectin,

cardiovascular risk assessment, 535, 536  
functions, 534, 535

Adrenomedullin,

functions and effects, 433, 434

heart failure levels, 434, 435

induction and secretion, 433

myocardial infarction levels, 434

Albumin, ischemia-modified albumin, 184,  
199, 200

- Angiotensin-converting enzyme (ACE),  
polymorphisms and cardiovascular  
disease, 594, 595
- ANP, *see* Atrial natriuretic peptide
- ApoB, *see* Apolipoprotein B
- ApoE, *see* Apolipoprotein E
- Apolipoprotein B (ApoB),  
association with other risk indicators, 505  
clinical applications, 506  
myocardial infarction prediction, 505  
rationale for use as biomarker, 503, 505  
therapy effects on levels, 506
- Apolipoprotein E (ApoE), alleles and  
cardiovascular disease, 598, 599
- Aspartate aminotransferase, history of  
biomarker use, 9, 10
- Aspirin,  
C-reactive protein response, 229, 253  
resistance,  
definition, 477, 478  
monitoring, 478–480  
outcomes, 478, 479
- Atherosclerosis,  
infection role,  
*Chlamydia pneumoniae*, 320–329  
clinical use prospects, 336, 337  
cytomegalovirus, 332–334  
*Helicobacter pylori*, 329–331  
herpes simplex virus, 334  
human immunodeficiency virus, 334  
influenza virus, 334, 335  
*Mycoplasma pneumoniae*, 331  
pathogen burden as aggregate  
serological risk factor, 335, 336  
inflammation,  
biomarkers, *see also specific  
biomarkers*,  
hierarchy of utility, 216  
prospects for clinical use, 217–219  
rationale in disease prediction and  
prognosis, 214, 215  
therapy guidance, 218  
role in disease, 208–212
- Atrial natriuretic peptide (ANP),  
clearance and half-life, 355, 356  
congestive heart failure levels, 360, 361  
diabetes levels, 363  
discovery, 348, 349, 363  
functions and effects,  
antiproliferative actions, 357, 358  
cardiac contractility effects, 357  
central nervous system actions, 359  
neurohormonal actions, 356, 357  
renal actions, 358, 359  
vascular actions, 356, 388–390  
gene regulation, 352, 353  
hypertension levels, 361  
myocardial ischemia levels, 362, 363, 414  
receptors and signaling, 353–355  
sources, 348  
synthesis and release, 349, 350
- B**
- BNP, *see* B-type natriuretic peptide
- B-type natriuretic peptide (BNP),  
acute coronary syndrome prognostic  
value,  
B-type natriuretic peptide, 415, 416,  
418  
combination with other risk markers,  
421  
N-terminal fragment of prohormone,  
418  
patient selection for early intervention,  
420  
recommendations, 420, 421  
risk stratification, 419  
timing of measurement, 418, 419  
age and gender effects on levels, 363,  
380, 381  
assays,  
blood sampling and storage, 379  
calibration and standardization, 377,  
378, 380  
commercial assays, 376, 377, 390, 391  
development, 375, 376  
false results and interference, 382, 383  
immunometric assays, 374, 375  
N-terminal fragment of prohormone,  
374, 378  
practical aspects, 383, 384  
sample stability, 379  
variability, 380, 381  
clearance and half-life, 355, 356  
congestive heart failure,  
comorbidity and influence on  
interpretation,  
diastolic dysfunction, 395, 396  
obesity, 396  
pulmonary disease, 394, 395  
renal insufficiency, 394  
diagnostics, 390, 392

- inpatient management,
    - frequency of testing, 404
    - high filling pressure, 401, 402
    - therapeutic monitoring, 404, 405
    - wet and dry peptide levels, 402–404
  - levels, 360, 361
  - risk stratification, 397–399
  - staging, 388
  - sudden cardiac death prediction, 399
  - triage of acute dyspnea patients, 392, 393, 396, 397
  - diabetes levels, 363
  - discovery, 349
  - functions and effects,
    - antiproliferative actions, 357, 358
    - cardiac contractility effects, 357
    - central nervous system actions, 359
    - neurohormonal actions, 356, 357
    - renal actions, 358, 359
    - vascular actions, 356, 388–390
  - gene regulation, 352, 353
  - myocardial ischemia,
    - diagnostics, 414
    - heart failure and death risk assessment
      - after ST-segment elevation myocardial infarction, 415
    - levels, 362, 363
    - prognostic value, 414, 415
    - stimuli for synthesis and release,
      - atherosclerosis, 414
      - hypoxia, 412, 413
      - ventricular dysfunction, 413
    - synthesis and release patterns, 410–412
  - point-of-care testing, 570
  - pulmonary embolism biomarker, 134–136
  - receptors and signaling, 353–355
  - sources, 348
  - synthesis and release, 350–352
  - troponin combination measurement in
    - heart failure, 125, 126
  - valvular heart disease levels, 362
  - ventricular dysfunction screening,
    - high-risk populations, 400
    - population-based screening, 399, 400
    - recommendations, 400
- C**
- CABG, *see* Coronary artery bypass graft
  - CAIII, *see* Carbonic anhydrase III
  - Carbonic anhydrase III (CAIII),
    - distribution, 20
    - myoglobin marker validation, 20
  - Cardiac trauma, troponin uses,
    - clinical role, 143
    - decision-making, 143
    - diagnosis, 142, 143
  - Cardioversion, troponin levels, 143, 144
  - CD40 ligand,
    - atherosclerosis role, 211, 212
    - combination with other markers, 552, 553
    - myocardial ischemia detection, 197, 198
    - platelet activation marker, 284–286
    - platelet shedding, 215
    - platelet surface marker, 460
  - CETP, *see* Cholesteryl ester transfer protein
  - CHF, *see* Congestive heart failure
  - Chlamydia pneumoniae*,
    - atherosclerosis role,
      - animal studies, 324–326
      - pathological evidence, 324
      - serological evidence, 321, 322, 323
      - therapeutic trials, 326–329
    - detection in blood, 322, 24
    - heat shock protein-60, acute coronary syndrome levels, 268
    - pathogenesis, 320
  - Cholesteryl ester transfer protein (CETP),
    - polymorphisms and cardiovascular disease, 598
  - Choline, myocardial ischemia detection, 198, 199
  - CK-MB, *see* Creatine kinase
  - Clopidogrel, therapy monitoring, 480–482
  - CMV, *see* Cytomegalovirus
  - CNP, *see* C-type natriuretic peptide
  - Complex diseases,
    - genetic determinant establishment,
      - association studies, 590, 591, 593
      - linkage analysis, 589, 590
      - simple disease comparison, 587–589
  - Computer modeling, combinations of markers, 21, 22
  - Congestive heart failure (CHF),
    - adhesion molecules, 307, 308
    - adrenomedullin levels, 434, 435
    - B-type natriuretic peptide,
      - comorbidity and influence on interpretation,
        - diastolic dysfunction, 395, 396

- obesity, 396
- pulmonary disease, 394, 395
- renal insufficiency, 394
- diagnostics, 390, 392
- inpatient management,
  - frequency of testing, 404
  - high filling pressure, 401, 402
  - therapeutic monitoring, 404, 405
  - wet and dry peptide levels, 402–404
- levels, 360, 361
- risk stratification, 397–399
- staging, 388
- sudden cardiac death prediction, 399
- triage of acute dyspnea patients, 392, 393, 396, 397
- C-reactive protein levels, 308, 309
- chemokine levels, 307
- clinical features, 119
- economic impact, 388
- epidemiology, 388
- erythrocyte sedimentation rate, 309
- inflammatory cytokine levels and effects,
  - clinical prospects, 310, 312
  - disease severity correlation, 303, 304
  - interleukin-1, 303
  - interleukin-6, 302, 303
  - prognostic value, 304, 305
  - risk assessment in asymptomatic patients, 306, 307
  - therapeutic targeting, 305, 306
  - therapy monitoring, 305
  - tumor necrosis factor- $\alpha$ , 296–302
- myotrophin levels, 441
- non-ST-elevation acute coronary syndrome, 85
- peripheral leukocyte subsets, 309, 310
- remodeling, 120
- ST2 levels, 432, 433
- troponin elevation,
  - combination measurement with B-type natriuretic peptide, 125, 126
  - frequency, 120
  - pathophysiology, 120, 121
  - prognostic value, 121, 123, 124
  - prospects for use, 126, 127
  - therapeutic response, 124, 125
- urocortin levels, 437
- urotensin levels, 438, 439
- Coronary artery bypass graft (CABG),
  - cardiac biomarker use,
    - cell injury, 50
    - elevation prevalence, 104
    - myocardial infarction interpretation
      - with biomarkers, 53
    - troponin elevation, 113
- C-reactive protein (CRP),
  - acute coronary syndrome risk stratification,
    - clinical decision making, 270
    - comparison with other inflammatory markers, 266, 267
    - cut-off values, 265, 266
    - patient subgroups, 272
    - percutaneous coronary intervention outcome prediction, 266
    - prognostic value, 262–264, 279, 280
    - prospects, 272
    - timing of testing, 270, 272
  - assays, 224, 225
  - atherosclerotic lesion expression, 215
  - cardiovascular risk prediction,
    - metabolic syndrome and diabetes risk, 245–247
    - practical considerations, 250
    - primary prevention, 240–245
    - renal disease, 247, 248
    - secondary prevention, 249
    - subclinical atherosclerosis, 248, 249
  - functions, 225
  - gene, 225
  - heart failure levels, 308, 309
  - interpretation of test results, 232
  - mediator function, 216
  - myocardial ischemia detection, 197
  - nonspecificity, 216, 217, 267
  - pathophysiology, 239, 240, 268–270
  - phospholipase A2 combination testing, 523, 525
  - risk stratification, 225, 226
  - screening recommendations, 254, 255
  - structure, 225
  - variability factors,
    - age, 226
    - assay types, 230
    - ethnicity, 226, 227
    - gender, 226, 227
    - lifestyle factors, 228, 229
    - medications, 229, 251–254
    - seasonal variability, 227, 228

- specimen collection and handling, 229, 230
  - standardization and reporting, 230–232
  - Creatine kinase,
    - CK-MB isoenzyme,
      - activity assays, 12, 13
      - combination of necrosis markers, 548
      - emergency department use, 62, 63, 65, 66
      - exercise effects on levels, 149, 150
      - index, 11
      - infarct size estimation, 98
      - isoforms, 133
      - mass assays, 13, 14, 16
    - exercise effects on release, 10, 11
    - isoenzymes, 11, 12
    - myocardial infarction diagnosis,
      - overview, 14, 16, 42
      - specificity, 44, 45
    - reaction catalyzed, 10
    - tissue distribution, 10
  - CRP, *see* C-reactive protein
  - cTnI, *see* Troponin
  - cTnT, *see* Troponin
  - C-type natriuretic peptide (CNP),
    - clearance and half-life, 355, 356
    - discovery, 349
    - functions and effects,
      - antiproliferative actions, 357, 358
      - cardiac contractility effects, 357
      - central nervous system actions, 359
      - neurohormonal actions, 356, 357
      - renal actions, 358, 359
      - vascular actions, 356
    - receptors and signaling, 353–355
    - sources, 348
    - synthesis and release, 353
  - Cytomegalovirus (CMV), atherosclerosis role, 332–334
- D**
- Diabetes,
    - C-reactive protein in risk prediction, 245–247
    - natriuretic peptide levels, 363
  - Dobutamine stress echocardiography (DSE),
    - cardiac biomarkers in chest pain protocols, 71–73
  - Drug-induced myocardial damage, troponin uses, 161, 152
  - DSE, *see* Dobutamine stress echocardiography
  - Dyslipidemia, atherogenic, 498
- E**
- ECG, *see* Electrocardiography
  - ED, *see* Emergency department
  - Electrocardiography (ECG), *see also*
    - Exercise electrocardiography,
      - myocardial ischemia detection, 181, 182, 289
  - Emergency department (ED),
    - cardiac biomarker use,
      - chest pain protocols, 66–73
      - CK-MB, 62, 63, 65, 66
      - myoglobin, 63–65
      - ninety-minute rapid rule-out protocols, 64, 65
      - novel markers, 66
      - troponin, 63, 65, 66
    - initial assessment of chest pain, 62
    - likelihood ratio impact on clinical decision making, 61, 62
  - End-stage renal disease (ESRD),
    - C-reactive protein in risk prediction, 247, 248
    - troponin levels, 152, 153
  - Endothelial cell markers,
    - circulating cells, 461
    - P-selectin, 460, 461
    - von Willebrand factor, 460, 461
  - Erythrocyte sedimentation rate (ESR), heart failure, 309
  - ESR, *see* Erythrocyte sedimentation rate
  - ESRD, *see* End-stage renal disease
  - Estrogen receptor, polymorphisms and cardiovascular disease, 596, 597
  - Exercise electrocardiography, cardiac biomarkers in chest pain protocols,
    - Cincinnati Heart ER program, 67
    - Cook County Hospital chest pain protocol, 68
    - Mayo Clinic chest pain protocol, 67, 68
    - UC Davis protocol, 68, 69
- F**
- Factor V Leiden, polymorphisms and cardiovascular disease, 597
  - Fatty acid-binding protein (H-FABP), distribution, 20



- kinetics of release, 20
- Fibrinogen,  
 assay, 224  
 polymorphisms and cardiovascular disease, 597  
 thrombosis marker, 455–457
- Flow cytometry, platelets, 473, 474
- Fractalkine, atherosclerosis role, 209
- Free fatty acids, *see* Unbound free fatty acids
- G**
- Glutathione peroxidase, myocardial ischemia detection, 200, 201
- Glycoprotein IIb/IIIa receptor,  
 antagonist monitoring, 475–477  
 platelet surface marker, 460
- Glycoprotein IIIa,  
 pharmacogenomics, 594  
 polymorphisms and coronary artery disease, 593, 594
- H**
- Heart failure, *see* Congestive heart failure
- Helicobacter pylori*,  
 atherosclerosis role,  
 pathological evidence, 30, 331  
 serological evidence, 330, 331  
 diseases, 329  
 epidemiology, 329
- Hemodynamic stress biomarkers,  
 adrenomedullin, 433–435  
 B-type natriuretic peptide, 428, 443  
 criteria, 427, 428  
 myotrophin, 440, 441  
 novel candidate markers, 441–443  
 ST2, 429–433  
 urocortin, 435–438  
 urotensin, 438–440
- Herpes simplex virus (HSV), atherosclerosis role, 334
- H-FABP, *see* Fatty acid-binding protein
- Historical perspective, cardiac biomarker use, 4–6, 9
- HIV, *see* Human immunodeficiency virus
- HMG-CoA reductase,  
 inhibitors, *see* Statins  
 polymorphisms and cardiovascular disease, 598
- Hormone replacement therapy, C-reactive protein response, 254
- HSV, *see* Herpes simplex virus
- Human immunodeficiency virus (HIV),  
 atherosclerosis role, 334
- Hypertension,  
 atrial natriuretic peptide levels, 361  
 urotensin levels, 438, 439
- I**
- Ideal characteristics, cardiac necrosis biomarkers, 5, 6
- IL-1, *see* Interleukin-1
- IL-6, *see* Interleukin-6
- IL-8, *see* Interleukin-8
- IL-10, *see* Interleukin-10
- IMA, *see* Ischemia-modified albumin
- Inflammation,  
 acute coronary syndrome, 261, 262  
 acute coronary syndrome pathogenesis, 212, 214  
 atherosclerosis role, 208–212  
 biomarkers in atherosclerosis, *see also specific biomarkers*,  
 hierarchy of utility, 216  
 prospects for clinical use, 217–219  
 rationale in disease prediction and prognosis, 214, 215  
 therapy guidance, 218  
 congestive heart failure and inflammatory cytokine levels and effects,  
 disease severity correlation, 303, 304  
 interleukin-1, 303  
 interleukin-6, 302, 303  
 prognostic value, 304, 305  
 risk assessment in asymptomatic patients, 306, 307  
 therapeutic targeting, 305, 306  
 therapy monitoring, 305  
 tumor necrosis factor- $\alpha$ , 296–302
- Influenza virus, atherosclerosis role, 334, 335
- Interferon- $\gamma$ , fibrous cap effects, 212
- Interleukin-1 (IL-1),  
 heart failure levels, 303  
 receptor, *see* ST2
- Interleukin-6 (IL-6), inflammation  
 biomarker in atherosclerosis, 214
- Interleukin-6, heart failure levels, 302, 303
- Interleukin-8 (IL-8), atherosclerosis role, 209
- Interleukin-10 (IL-10), inflammatory balance marker, 288, 289
- Ischemia, cardiomyocyte changes, 4

- Ischemia-modified albumin (IMA),  
myocardial ischemia marker, 184, 199,  
200
- L**
- Lactate dehydrogenase, history of biomarker  
use, 6, 9
- LDL, *see* Low-density lipoprotein
- Likelihood ratio, impact on clinical decision  
making, 61, 62
- Linkage analysis, complex diseases, 589,  
590
- Lipocalin, hemodynamic stress biomarker  
prospects, 442
- Lipoprotein(a),  
cardiovascular risk assessment, 509  
clinical applications, 510
- Lipoprotein lipase (LPL),  
cardiovascular risk assessment, 534  
functions, 533
- Lipoxygenases,  
functions, 531  
5-lipoxygenase, 532, 533  
12/15-lipoxygenase, 532  
polymorphisms and cardiovascular  
disease, 602
- Low-density lipoprotein (LDL),  
cholesterol content,  
approximation,  
imprecision, 500, 501  
origins, 500  
overview, 499  
problems, 501, 502  
cardiovascular risks, 498  
case study, 513–515  
non-HDL-cholesterol calculation, 502,  
503  
oxidized form,  
antioxidant therapy effects, 530, 531  
cardiovascular risk assessment,  
cross-sectional studies, 529  
prospective studies, 5229, 530  
overview, 183, 528, 529  
particle number,  
case study, 513–515  
cholesterol content comparison and  
limitations, 506, 507  
incorporation into clinical practice,  
510–512  
measurement, 508, 509  
sizing, 498, 499  
target values, 503, 504
- LPL, *see* Lipoprotein lipase
- M**
- Macrophage colony-stimulating factor (M-  
CSF), atherosclerosis role, 209
- Macrophage inflammatory protein-1 $\alpha$   
(MCP-1 $\alpha$ ), heart failure levels, 307
- Magnetic resonance tomography (MRT),  
infarct size estimation, 97, 99, 100
- Mass measurement, definition, 6
- Mass spectrometry (MS), biomarker  
discovery, 579–581
- Matrix metalloproteinases (MMPs),  
atherosclerotic lesion expression, 212  
plaque rupture role, 280
- MCP-1, *see* Monocyte chemoattractant  
protein-1
- MCP-1 $\alpha$ , *see* Macrophage inflammatory  
protein-1 $\alpha$
- M-CSF, *see* Macrophage colony-stimulating  
factor
- MEF2A*, polymorphisms and cardiovascular  
disease, 601, 602
- Mendelian genetics, simple diseases, 587,  
588
- Metabolic syndrome, C-reactive protein in  
risk prediction, 245–247
- Metformin, C-reactive protein response, 254
- Methylenetetrahydrofolate reductase  
(MTHFR), polymorphisms and  
cardiovascular disease, 595, 596
- MMPs, *see* Matrix metalloproteinases
- Monocyte chemoattractant protein-1 (MCP-  
1),  
atherosclerosis role, 209  
C-reactive protein induction, 269  
heart failure levels, 307
- Monocyte–platelet aggregates,  
clinical use prospects, 491  
coronary artery disease,  
marker, 489  
pathophysiology, 490  
detection, 489, 490  
molecular basis of interactions, 488, 489
- MPI, *see* Myocardial perfusion imaging
- MPO, *see* Myeloperoxidase
- MRT, *see* Magnetic resonance tomography
- MS, *see* Mass spectrometry
- MTHFR, *see* Methylenetetrahydrofolate  
reductase

- Mycoplasma pneumoniae*, atherosclerosis role, 331
- Myeloperoxidase (MPO),  
myocardial ischemia detection, 198  
oxidative stress marker, 286–288
- Myocardial ischemia, B-type natriuretic peptide,  
diagnostics, 414  
heart failure and death risk assessment after ST-segment elevation myocardial infarction, 415  
levels, 362, 363  
prognostic value, 414, 415  
stimuli for synthesis and release, atherosclerosis, 414  
hypoxia, 412, 413  
ventricular dysfunction, 413  
synthesis and release patterns, 410–412
- Myocardial ischemia,  
biomarkers, *see also specific biomarkers*, applications,  
diagnosis, 180, 181  
pathophysiology, 180  
risk stratification, 178–180  
approaches in development, 183–186, 195  
challenges in development,  
gold standard limitations, 187, 188  
rule-in versus rule-out conundrum, 188, 189  
evaluation criteria, 195, 196  
requirements, 195, 196  
detection,  
electrocardiography, 181, 182  
myocardial perfusion imaging, 182  
natriuretic peptide levels, 362, 363
- Myocardial perfusion imaging (MPI),  
chest pain protocol incorporation, 70–73  
myocardial infarction diagnosis, 69, 70  
myocardial ischemia detection, 182  
technetium-based agents, 184–186
- Myoglobin,  
emergency department use, 63–65  
functions, 18  
myocardial infarction diagnosis,  
carbonic anhydrase III validation, 20,  
redefinition, 18, 19  
sensitivity, 45  
specificity, 45  
release, 18, 74
- Myosin light chain, history of biomarker use, 9
- Myotrophin,  
functions, 440, 441  
heart failure levels, 441
- N**
- Natriuretic peptides, *see* Atrial natriuretic peptide; B-type natriuretic peptide; C-type natriuretic peptide
- NEP, *see* Neutral endopeptidase
- Neutral endopeptidase (NEP),  
natriuretic peptide clearance, 355  
therapeutic targeting, 361
- Nitric oxide synthase (NOS), endothelial gene polymorphisms and cardiovascular disease, 596
- Non-HDL-cholesterol,  
calculation, 502, 503  
target values, 503, 504
- Non-ST-elevation acute coronary syndrome,  
definition, 80  
epidemiology, 80, 81  
troponin biomarker use,  
combination with other markers, 85  
diagnostic challenge, 81, 82  
interpretation, 86  
isoform differences, 88  
prognostic challenge,  
death and myocardial infarction, 82–84  
heart failure, 85  
mechanisms, 87, 88  
revascularization rate, 85  
risk stratification,  
ESC/ACC recommendations, 89  
integrated approach, 85, 86  
low-level elevation, 89, 90  
timing of measurement, 89  
treatment challenges, 86, 87
- NOS, *see* Nitric oxide synthase
- Nourins, myocardial ischemia detection, 201
- P**
- PAI-I, *see* Plasminogen activator inhibitor-I
- PAPP-A, *see* Pregnancy-associated plasma protein A
- PCI, *see* Percutaneous coronary intervention
- PCR, *see* Polymerase chain reaction
- PDGF, *see* Platelet-derived growth factor
- PE, *see* Pulmonary embolism
- Percutaneous coronary intervention (PCI),  
C-reactive protein in outcome prediction, 266

- cardiac biomarker use,
  - cell injury, 50
  - elevation prevalence, 104
  - myocardial infarction interpretation
    - with biomarkers, 52, 53
- troponin elevation,
  - baseline measurements, 111
  - factors affecting,
    - inflammation, 107
    - procedural complications, 105
    - prolonged balloon inflation, 104, 105
    - stenting versus balloon angioplasty, 105, 107
  - incidence, 104, 106
  - isoenzyme sensitivity, 108, 111
  - management of patients, 113
  - prevention, 111, 112
  - prognostic value, 107, 108
- Phospholipase A2 (PLA<sub>2</sub>),
  - lipoprotein-associated enzyme,
    - assay, 525, 526
    - cardiovascular risk assessment,
      - overview, 523, 524
      - prospective nested case-control studies, 521, 522
      - prospective population-based study, 523
    - C-reactive protein combination testing, 523, 525
    - functions, 520
    - isoforms, 520
    - statin effects, 526
  - type II secretory enzyme,
    - atherosclerosis marker, 280, 528
    - functions, 527, 528
    - induction, 526, 527
- PLA<sub>2</sub>, *see* Phospholipase A<sub>2</sub>
- Placental growth factor (PIGF),
  - atherosclerotic plaque stability marker, 282–284
  - vascular inflammation induction, 282, 283
- Plasminogen activator inhibitor-I (PAI-I),
  - anticoagulation system biomarker, 459
  - C-reactive protein induction, 269
  - polymorphisms and cardiovascular disease, 600
- Platelet,
  - aspirin resistance, *see* Aspirin assays,
  - aggregation assays,
    - flow studies, 472, 473
    - turbidic aggregometry, 470, 471
    - Ultra Rapid Platelet Function Assay, 472
    - whole-blood assay, 471
  - bleeding time, 469
  - clopidogrel therapy monitoring, 480–482
  - flow cytometry, 473, 474
  - glycoprotein IIb/IIIa receptor
    - antagonist monitoring, 475–477
  - mechanical property assessment, 474, 475
  - Platelet Function Analyzer-100, 469, 470
  - procoagulant surface expression, 475
  - deposition and activation in thrombosis, 453
  - monocyte aggregates, *see* Monocyte-platelet aggregates
  - plug formation,
    - extension, 469
    - initiation, 468
    - perpetuation, 469
  - surface markers,
    - CD40 ligand, 460
    - glycoprotein IIb/IIIa receptor, 460
- Platelet-derived growth factor (PDGF),
  - atherosclerosis role, 210, 211
- PIGF, *see* Placental growth factor
- POC testing, *see* Point-of-care testing
- Point-of-care (POC) testing,
  - acute coronary syndrome,
    - clinical decision making, 569
    - decision limits, 569, 570
    - diagnosis, 567, 568
    - impact on outcomes, 570
    - risk stratification, 568, 569
  - assays, 561–565
  - B-type natriuretic peptide, 570
  - prospects, 571
  - rationale,
    - convenience, 566, 567
    - speed, 565, 566
- Polymerase chain reaction (PCR), biomarker discovery, 581
- Pregnancy-associated plasma protein A (PAPP-A),
  - atherosclerotic plaque stability marker, 280, 282

- myocardial ischemia detection, 198
  - Proteomics,
    - biomarker discovery,
      - experiment overview, 578, 579
      - mass spectrometry, 579–581
      - prerequisites for analysis, 577, 578
      - two-dimensional gel electrophoresis, 579
    - overview, 576, 577
    - plasma proteomics,
      - cardiovascular disease, 582, 583
      - experimental design, 582
      - signatures, 583–585
    - prospects, 585, 586
  - Prothrombin, polymorphisms and cardiovascular disease, 597
  - P-selectin,
    - endothelial cell marker, 460, 461
    - monocyte–platelet aggregate role, 488, 489
  - Pulmonary embolism (PE),
    - biomarker use,
      - B-type natriuretic peptide, 134–136
      - pathophysiology of hemodynamic stress and cardiac injury, 132
    - prospects, 136
    - troponin, 133, 144, 169
  - outcomes, 129, 130
  - risk stratification,
    - classic approach, 130
    - contemporary tools, 130, 131
    - importance, 131, 132
- Q,R**
- Qualitative testing, advantages, 19
  - Reactive oxygen species (ROS),
    - atherothrombosis role, 183, 184
  - ROS, *see* Reactive oxygen species
  - RPDA, *see* Ultegra Rapid Platelet Function Assay
- S**
- SAA, *see* Serum amyloid A
  - Selectin, *see* P-selectin
  - Sepsis,
    - myocarditis levels, 147, 148
    - troponin levels,
      - frequency of elevation, 144, 145
      - pathobiology, 144, 145
      - prognostic value, 145
      - testing value, 146
  - Serial sampling, biomarkers, 19, 20
  - Serum amyloid A (SAA),
    - acute coronary syndrome risk stratification, 266
    - assay, 224
  - Single nucleotide polymorphisms (SNPs),
    - candidate genes in cardiovascular disease, *see specific genes*
    - complex diseases, 589, 590
    - genome-wide scans, 601, 602
    - multilocus studies, 599–601
  - Single-photon emission computed tomography (SPECT), infarct size estimation, 99, 100
  - SNPs, *see* Single nucleotide polymorphisms
  - SPECT, *see* Single-photon emission computed tomography
  - ST2,
    - functions, 429, 430
    - heart failure levels, 432, 433
    - myocardial infarction levels, 430–432
  - Statins,
    - C-reactive protein, 229, 251–253
    - phospholipase A2 effects, 526
  - ST-elevation myocardial infarction (STEMI),
    - biomarker use,
      - confirmation of diagnosis, 94
      - infarct size estimation, 97–100
      - reperfusion therapy monitoring,
        - percutaneous coronary intervention, 95, 96
        - thrombolytic therapy, 94, 95
      - risk stratification, 96, 97
    - diagnostic challenges, 94, 560
  - STEMI, *see* ST-elevation myocardial infarction
  - Stroke, troponin findings, 148
- T**
- Thiazolidinedione, C-reactive protein response, 254
  - Thrombin, thrombosis marker, 457
  - Thrombomodulin, anticoagulation system biomarker, 458
  - Thrombosis,
    - anticoagulant pathways in homeostasis maintenance, 454, 455
    - anticoagulation system biomarkers,
      - plasminogen activator inhibitor-1, 459
      - thrombomodulin, 458
      - tissue-type plasminogen activator, 459

- coagulation factor activation and thrombin generation, 453
- dynamics, 452
- endothelial cell markers,
  - circulating cells, 461
  - limitations, 461
  - P-selectin, 460, 461
  - von Willebrand factor, 460, 461
- initiation, 452
- markers,
  - fibrinogen, 455–457
  - thrombin, 457
  - tissue factor, 457, 458
- platelet deposition and activation, 453
- platelet surface markers,
  - CD40 ligand, 460
  - glycoprotein IIb/IIIa receptor, 460
- prospects, 461, 462
- Thrombospondin,
  - hemodynamic stress biomarker prospects, 442, 443
  - polymorphisms and cardiovascular disease, 600, 601
- Tissue factor, thrombosis marker, 457, 458
- Tissue-type plasminogen activator (tPA),
  - anticoagulation system biomarker, 459
- TNF- $\alpha$ , *see* Tumor necrosis factor- $\alpha$
- tPA, *see* Tissue-type plasminogen activator
- Troponin,
  - aggregation of subunits, 165–167
  - antibody specificity, 31
  - cardiac trauma uses,
    - clinical role, 143
    - decision-making, 143
    - diagnosis, 142, 143
  - cardioversion levels, 143, 144
  - combination with other markers,
    - B-type natriuretic peptide, 549, 550
    - C-reactive protein, 549
    - triple markers, 550–552
  - congestive heart failure elevation,
    - combination measurement with B-type natriuretic peptide, 125, 126
    - frequency, 120
    - pathophysiology, 120, 121
    - prognostic value, 121, 123, 124
    - prospects for use, 126, 127
    - therapeutic response, 124, 125
  - congestive heart failure marker, 140, 142
  - coronary artery bypass graft elevation,
    - 113
    - cytosolic versus structural pools, 167–170
    - drug-induced myocardial damage uses,
      - 161, 152
    - emergency department use, 63, 65, 66
    - end-stage renal disease levels, 152, 153
    - exercise effects on levels, 150
    - functions, 163
    - infarct size estimation, 98, 99
    - interfering factors in assays, 153, 154
    - irreversible injury and release, 45, 46
    - isoforms, 16, 17, 28, 44
    - kinetics of cardiac release and clearance,
      - 5, 16, 17, 28, 43, 44
    - limitations as biomarkers, 5
    - myocardial infarction diagnosis,
      - cutoff values, 17, 18, 34–37, 46, 47
      - ESC/ACC task force definition, 42, 43, 51–53
      - historical perspective, 17, 42
      - imprecision issues, 48, 49
      - sensitivity, 45, 50, 51
      - specificity, 44
      - turnaround time of assay, 38
    - myocarditis levels, 147, 148
    - non-ST-elevation acute coronary syndrome biomarker use,
      - combination with other markers, 85
      - diagnostic challenge, 81, 82
      - interpretation, 86
      - isoform differences, 88
      - prognostic challenge,
        - death and myocardial infarction, 82–84
        - heart failure, 85
        - mechanisms, 87, 88
        - revascularization rate, 85
      - risk stratification,
        - ESC/ACC recommendations, 89
        - integrated approach, 85, 86
        - low-level elevation, 89, 90
      - timing of measurement, 89
      - treatment challenges, 86, 87
    - pediatric applications, 150
    - percutaneous coronary intervention
      - elevation,
        - baseline measurements, 111
        - factors affecting,
          - inflammation, 107
        - procedural complications, 105
        - prolonged balloon inflation, 104, 105

- stenting versus balloon angioplasty, 105, 107
  - incidence, 104, 106
  - isoenzyme sensitivity, 108, 111
  - prevention, 111, 112
  - prognostic value, 107, 108
  - management of patients, 113
  - perioperative myocardial infarction
    - detection in noncardiac surgery, 148
  - phosphorylation and kinases, 164
  - proteolysis,
    - biological activity of fragments, 171, 172
    - cleavage sites, 165
    - fragment analysis,
      - applications, 170, 171
      - assays, 171
  - pulmonary embolism biomarker, 133, 144, 169
  - reversible cardiac injury detection, 196
  - risk stratification, 37, 38
  - sample collection, 38
  - sepsis levels,
    - frequency of elevation, 144, 145
    - pathobiology, 144, 145
    - prognostic value, 145
    - testing value, 146
  - standardization of assays,
    - clinical implications, 31, 32
    - interferences, 34
    - reference materials, 28, 32–34
  - stroke findings, 148
  - Tumor necrosis factor- $\alpha$  (TNF- $\alpha$ ),
    - cardiac effects,
      - left ventricular function, 299, 300
      - left ventricular remodeling, 300–302
      - functions, 298, 299
      - heart failure levels, 296–302
      - history of study, 297, 298
      - receptors, 299
  - Two-dimensional gel electrophoresis,
    - biomarker discovery, 579
- ## U
- Ultegra Rapid Platelet Function Assay (RPDA), principles, 472
  - Unbound free fatty acids, myocardial ischemia detection, 186, 199
  - Urocortin,
    - cardiovascular system expression, 436, 437
    - functions and effects, 435–438
    - heart failure levels, 437
  - Urotensin,
    - agonists and antagonists, 440
    - functions and effects, 439, 440
    - heart failure levels, 438, 439
    - hypertension levels, 438, 439
    - receptor, 438
- ## V
- Valsartan, C-reactive protein response, 254
  - Valvular heart disease, B-type natriuretic peptide levels, 362
  - Vascular cell adhesion molecule-1 (VCAM-1), atherosclerosis role, 209
  - VCAM-1, *see* Vascular cell adhesion molecule-1
  - Vitamin E, oxidized low-density lipoprotein effects, 530, 531
  - von Willebrand factor (vWF),
    - endothelial cell marker, 460, 461
    - function, 452, 468
  - vWF, *see* von Willebrand factor